

**10<sup>TH</sup>**  
EDITION

**BUILDING**  
**CONSTRUCTION**  
**HANDBOOK**

**ROY CHUDLEY & ROGER GREENO**

INDUSTRY  
BESTSELLER

INCORPORATING  
CURRENT BUILDING  
& CONSTRUCTION  
REGULATIONS

ROUTLEDGE

# BUILDING CONSTRUCTION HANDBOOK

The *Building Construction Handbook* is THE authoritative reference for all construction students and professionals. Its detailed drawings clearly illustrate the construction of building elements, and have been an invaluable guide for builders since 1988. The principles and processes of construction are explained with the concepts of design included where appropriate. Extensive coverage of building construction practice, techniques, and regulations representing both traditional procedures and modern developments are included to provide the most comprehensive and easy to understand guide to building construction.

This new edition has been updated to reflect recent changes to the building regulations, as well as new material on the latest technologies used in domestic construction.

*Building Construction Handbook* is the essential, easy-to-use resource for undergraduate and vocational students on a wide range of courses including NVQ and BTEC National, through to Higher National Certificate and Diploma, to Foundation and three-year Degree level. It is also a useful practical reference for building designers, contractors and others engaged in the construction industry.

**Roger Greeno** is a well-known author of construction texts. He has extensive practical and consultancy experience in the industry, in addition to lecturing at several colleges of further and higher education, and the University of Portsmouth. He has also examined for City & Guilds, Edexcel, the Chartered Institute of Building and the University of Reading.

**Roy Chudley**, formerly Senior Lecturer in Building Technology at the Guildford College of Technology, U.K, is an established author of numerous respected construction texts.

*This page intentionally left blank*

# **BUILDING CONSTRUCTION HANDBOOK**

**Tenth edition**

**Roy Chudley**  
**and**  
**Roger Greeno**

First edition published 1998  
by Butterworth-Heinemann

This edition published 2014  
by Routledge  
2 Park Square, Milton Park, Abingdon, Oxon, OX14 4RN

Simultaneously published in the USA and Canada  
by Routledge  
711 Third Avenue, New York, NY 10017

*Routledge is an imprint of the Taylor & Francis Group, an informa business*

© 2014 Roy Chudley and Roger Greeno

The right of Roy Chudley and Roger Greeno to be identified as author of this work has been asserted by them in accordance with sections 77 and 78 of the Copyright, Designs and Patents Act 1988.

All rights reserved. No part of this book may be reprinted or reproduced or utilised in any form or by any electronic, mechanical, or other means, now known or hereafter invented, including photocopying and recording, or in any information storage or retrieval system, without permission in writing from the publishers.

Knowledge and best practice in this field are constantly changing. As new research and experience broaden our understanding, changes in research methods, professional practices, or medical treatment may become necessary.

Practitioners and researchers must always rely on their own experience and knowledge in evaluating and using any information, methods, compounds, or experiments described herein. In using such information or methods they should be mindful of their own safety and the safety of others, including parties for whom they have a professional responsibility.

To the fullest extent of the law, neither the Publisher nor the authors, contributors or editors, assume any liability for any injury and/or damage to persons or property as a matter of products liability, negligence or otherwise, or form and use or operation of any methods, products, instructions, or ideas contained in the material herein.

*British Library Cataloguing in Publication Data*

A catalogue record for this book is available from the British Library

*Library of Congress Cataloging-in-Publication Data*

A catalog record has been requested for this book

ISBN13: 978-0-415-83638-8 (pbk)

ISBN13: 978-1-315-78032 -0 (ebk)

Typeset in Chudley  
by Taylor & Francis Books

# CONTENTS

**Preface to Tenth edition xi**

## **Part One General**

Built environment	2
The structure	5
Primary and secondary elements	12
Component parts and functions	15
Construction activities	19
Construction documents	20
Construction drawings	21
Building survey	28
Energy Performance Certificate	32
Method statement and programming	36
Weights and densities of building materials	38
Imposed floor loads	40
Drawings – notations	41
Planning application	45
Modular coordination	52
Construction regulations	54
CDM regulations	55
Safety signs and symbols	56
Building Regulations	58
Accredited construction details	71
Code for Sustainable Homes	72
British Standards	73
European Standards	74
Product and practice accreditation	76
CI/SfB system of coding	78
CPI System of Coding	79
Uniclass system of coding	80

## **Part Two Site Works**

Site survey	86
Site measurement	87
Site investigations	90
Soil investigation	93
Soil assessment and testing	100
Site layout considerations	112

## Contents

Site security	115
Site lighting and electrical supply	118
Site office accommodation	122
Site health and welfare provision	123
Materials storage	127
Materials testing	132
Timber decay and treatment	147
Protection orders for trees and structures	151
Locating public utility services	153
Setting out	154
Levels and angles	159
Road construction	162
Tubular scaffolding and scaffolding systems	172
Shoring systems	186
Demolition	195

### **Part Three Builders Plant**

General considerations	202
Bulldozers	205
Scrapers	206
Graders	207
Tractor shovels	208
Excavators	209
Transport vehicles	214
Hoists	217
Rubble chutes and skips	220
Cranes	221
Concreting plant	233

### **Part Four Substructure**

Foundations – function, materials and sizing	244
Foundation beds	253
Short bored pile foundations	259
Foundation types and selection	261
Piled foundations	266
Retaining walls	287
Gabions and mattresses	301
Basement excavations and construction	304
Waterproofing basements	313
Excavations	319
Concrete production	325
Cofferdams	333
Steel sheet piling	334
Caissons	337

Underpinning	341
Ground water control	350
Soil stabilisation and improvement	360
Reclamation of waste land	365
Treatment of contaminated subsoil	366

### **Part Five Superstructure – 1**

Choice of materials	370
Brick and block walls	379
Cavity walls	400
Damp-proof courses and membranes	408
Gas-resistant membranes	415
Calculated brickwork	417
Mortars	422
Arches and openings	425
Windows	432
Glass and glazing	448
Doors	462
Crosswall construction	471
Framed construction	475
Rendering to external walls	479
Cladding to external walls	482
Roofs – basic forms	490
Pitched roofs	494
Double lap tiling	505
Single lap tiling	514
Slating	516
Timber flat roofs	522
Dormer windows	537
Green roofs	546
Thermal insulation	548
U-values	549
Thermal bridging	580
Access for the disabled	586

### **Part Six Superstructure – 2**

Reinforced concrete slabs	592
Reinforced concrete framed structures	596
Reinforcement types	606
Structural concrete, fire protection	609
Formwork	610
Precast concrete frames	617
Prestressed concrete	621



## Contents

Structural steelwork sections	628
Structural steelwork connections	633
Structural fire protection	638
Portal frames	646
Composite timber beams	655
Multi-storey structures	658
Roof sheet coverings	665
Long span roofs	670
Shell roof construction	684
Membrane roofs	693
Rooflights	695
Panel walls	699
Rainscreen cladding	705
Structural glazing	708
Curtain walling	710
Concrete claddings	714
Concrete surface finishes	721
Concrete surface defects	725

### **Part Seven Internal Construction and Finishes**

Internal elements	728
Internal walls	729
Construction joints	734
Internal walls, fire protection	736
Party/separating walls	737
Partitions	739
Strut design	741
Plasters and plastering	746
Dry lining techniques	750
Plasterboard	753
Wall tiling	756
Domestic floors and finishes	758
Large cast in-situ ground floors	766
Concrete floor screeds	768
Timber suspended upper floors	771
Lateral restraint	774
Timber beam design	777
Holing and notching joists	780
Timber floors, fire protection	782
Reinforced concrete suspended floors	784
Precast concrete floors	789
Raised access floors	794
Sound insulation	795
Timber, concrete and metal stairs	808

Internal doors 834  
Doorsets 837  
Fire-resisting doors 838  
Plasterboard ceilings 844  
Suspended ceilings 845  
Paints and painting 850  
Joinery production 854  
Composite boarding 860  
Plastics in building 862

**Part Eight Domestic Services**

Drainage effluents 868  
Subsoil drainage 869  
Surface water removal 871  
Road drainage 876  
Rainwater installations 878  
Drainage systems 882  
Drainage – pipe sizes and gradients 891  
Water supply 892  
Cold water installations 894  
Hot water installations 896  
Flow controls 901  
Cisterns and cylinders 902  
Pipework joints 904  
Sanitary fittings 905  
Single and ventilated stack systems 908  
Hot water heating systems 913  
Electrical supply and installation 917  
Gas supply and gas fires 926  
Open fireplaces and flues 930  
Services – fire stops and seals 939  
Telephone installations 940  
Electronic communications installations 941

**Index 943**

*This page intentionally left blank*

## **PREFACE TO TENTH EDITION**

The *Building Construction Handbook* originated in 1982 as a series of four “check-books” written and illustrated by Roy Chudley. In 1988 these successful study guides were consolidated into one volume under the present title. The format of comprehensive illustrations and support text has been maintained as revisions and updates are incorporated into new editions. This latest edition contains a fresh assessment of the practices, procedures, guidance and legislation appropriate to construction and maintenance of housing and other low-rise buildings. It also includes applications to medium and larger scale structures for commercial and industrial purposes.

Much of the work from earlier editions is retained as an important reference, acknowledging that the industry end product generally has a long life span representative of high capital investment. Product aftercare in the form of maintenance, repair, renovation, refurbishment, extensions and alterations can represent some 50% of the industry turnover, much more when bank lending is limited for new development. For this purpose, many established and traditional practices shown in earlier editions are retained. Existing practices also benchmark development as a basis from which contemporary design and technology evolve. This is in response to political, social and economic requirements through legislative directives for environmental issues, energy regulation, fuel conservation and the need for sustainability in construction.

The content of the book is extensive, although no textbook, not least this one, could ever incorporate all practices experienced in an industry so diverse as construction. The content is not exemplar and neither does it attempt to be prescriptive. It is a perspective of construction principles including guidance to processes and, where appropriate, associated design. Building is to some extent determined by availability of materials and skilled operatives; therefore local, regional and national factors will also be responsible for some variation.

Supplementary study material and detail can be obtained from professional journals, legislative papers, manufacturers’ product literature, the many cross-references in the text and attending exhibits and seminars. The most valuable learning resource is observing and monitoring construction in progress.

RG 2014

*This page intentionally left blank*

# 1 GENERAL

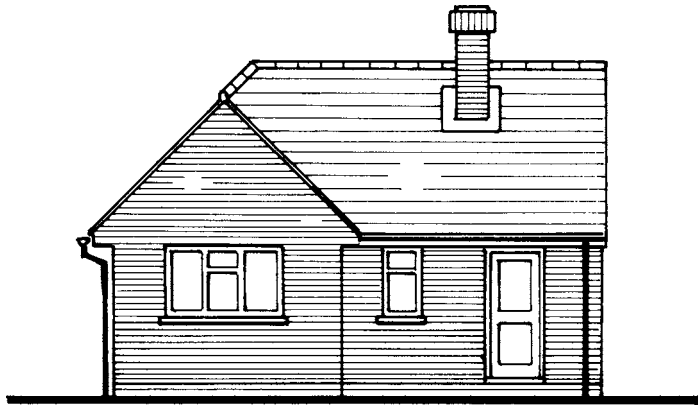

BUILT ENVIRONMENT  
THE STRUCTURE  
PRIMARY AND SECONDARY ELEMENTS  
COMPONENT PARTS AND FUNCTIONS  
CONSTRUCTION ACTIVITIES  
CONSTRUCTION DOCUMENTS  
CONSTRUCTION DRAWINGS  
BUILDING SURVEY  
ENERGY PERFORMANCE CERTIFICATES  
METHOD STATEMENT AND PROGRAMMING  
WEIGHTS AND DENSITIES OF BUILDING MATERIALS  
IMPOSED FLOOR LOADS  
DRAWINGS – NOTATIONS  
PLANNING APPLICATION  
MODULAR COORDINATION  
CONSTRUCTION REGULATIONS  
CDM REGULATIONS  
SAFETY SIGNS AND SYMBOLS  
BUILDING REGULATIONS  
ACCREDITED CONSTRUCTION DETAILS  
CODE FOR SUSTAINABLE HOMES  
BRITISH STANDARDS  
EUROPEAN STANDARDS  
PRODUCT AND PRACTICE ACCREDITATION  
CI/SFB SYSTEM OF CODING  
CPI SYSTEM OF CODING  
UNICLASS SYSTEM OF CODING

# Built Environment

Environment = surroundings which can be natural, man-made or a combination of these.

Built Environment = created by man with or without the aid of the natural environment.

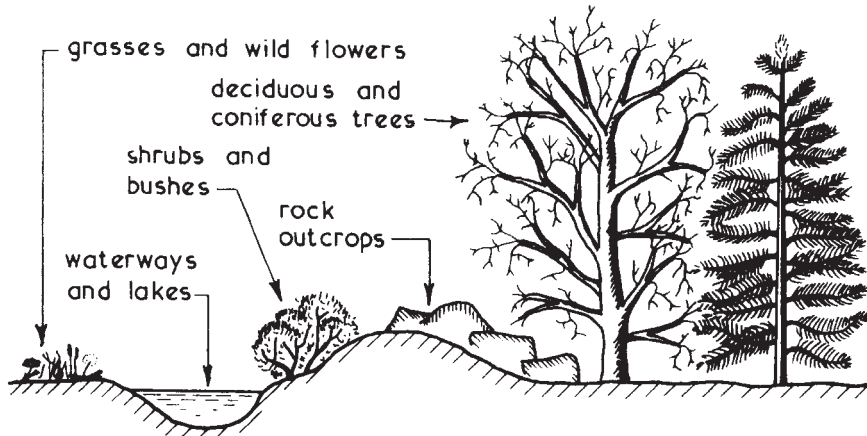

ELEMENTS of the NATURAL ENVIRONMENT

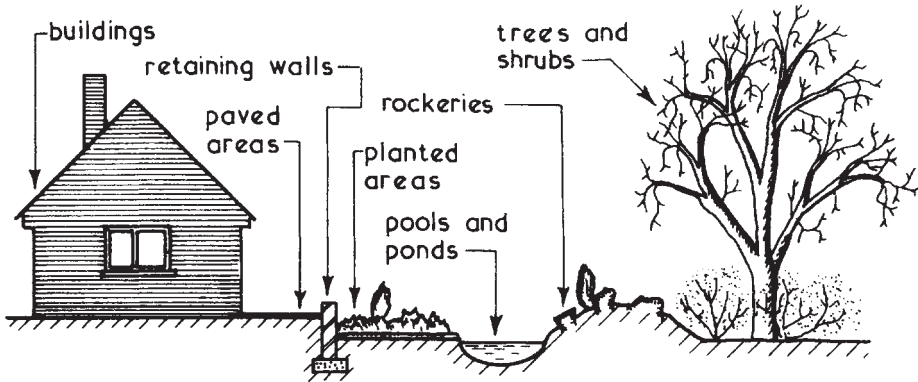

ELEMENTS of the BUILT ENVIRONMENT (EXTERNAL)

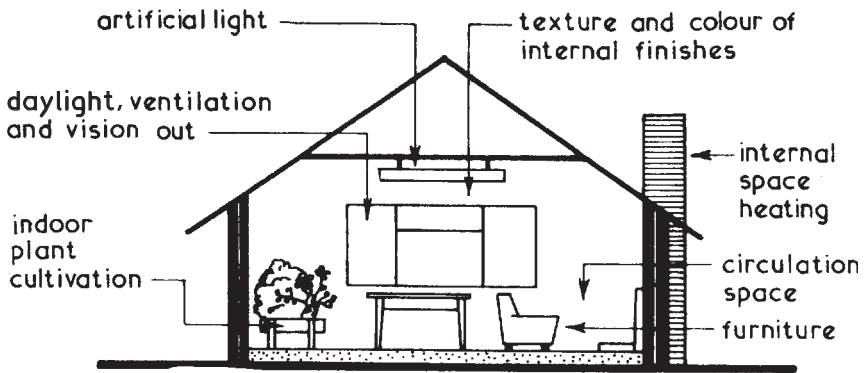

ELEMENTS of the BUILT ENVIRONMENT (INTERNAL)

Environmental Considerations:

1. Planning requirements.
2. Building Regulations.
3. Land restrictions by vendor or lessor.
4. Availability of services.
5. Local amenities including transport.
6. Subsoil conditions.
7. Levels and topography of land.
8. Adjoining buildings or land.
9. Use of building.
10. Daylight and view aspects.

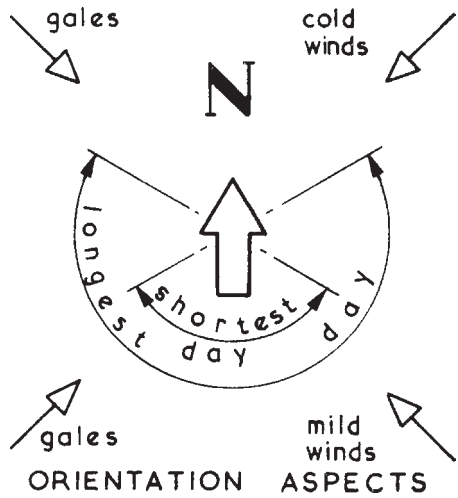

Examples ~

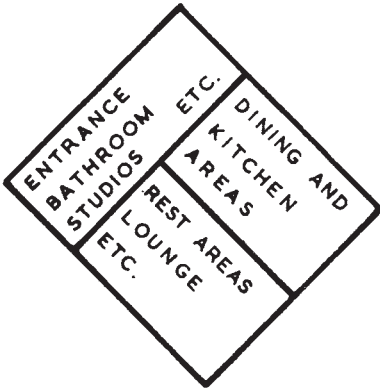

HOUSES

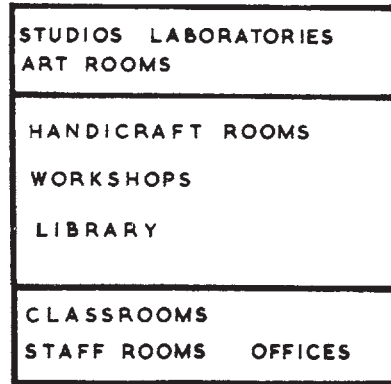

SCHOOLS

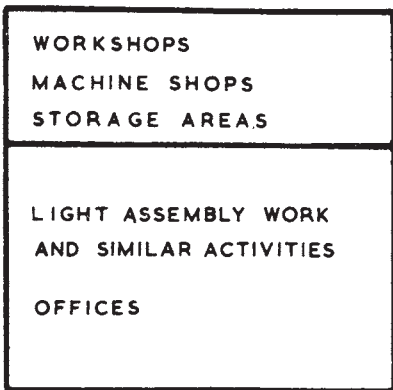

FACTORIES

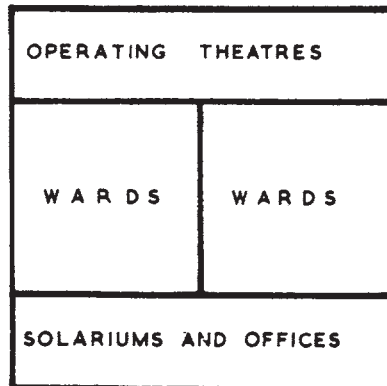

HOSPITALS



# Built Environment

## Physical Considerations:

1. Natural contours of land.
2. Natural vegetation and trees.
3. Size of land and/or proposed building.
4. Shape of land and/or proposed building.
5. Approach and access roads and footpaths.
6. Services available.
7. Natural waterways, lakes and ponds.
8. Restrictions such as rights of way; tree preservation and ancient buildings.
9. Climatic conditions created by surrounding properties, land or activities.
10. Proposed future developments.

## Examples ~

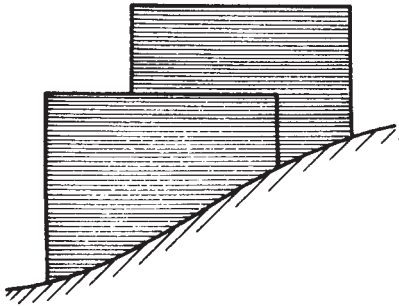

Split level construction to form economic shape.

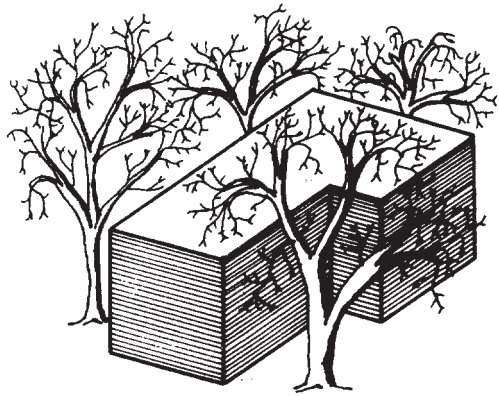

Shape determined by existing trees.

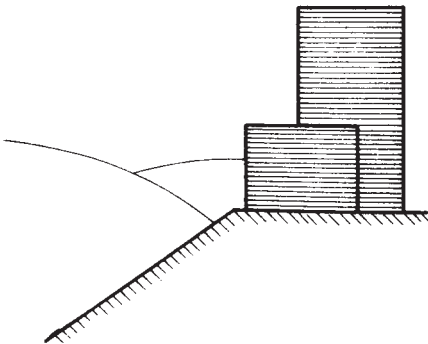

Plateau or high ground solution giving dry site conditions on sloping sites.

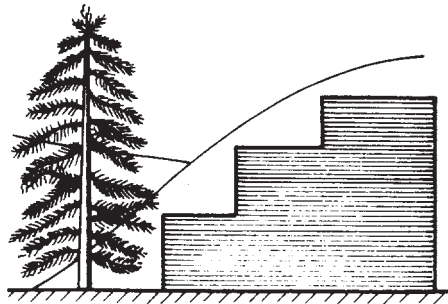

Stepped elevation or similar treatment to blend with the natural environment.

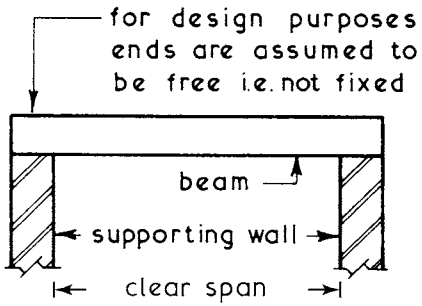

SIMPLY SUPPORTED BEAM

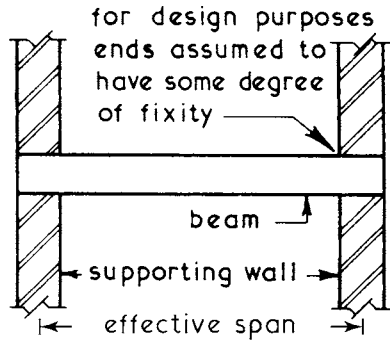

BUILT-IN BEAM

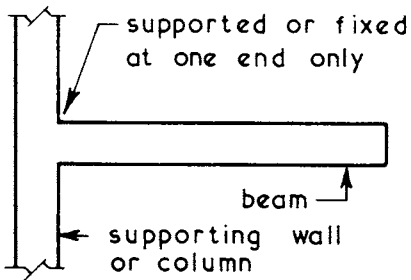

CANTILEVER BEAM

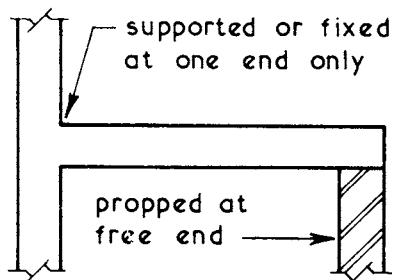

PROPPED CANTILEVER

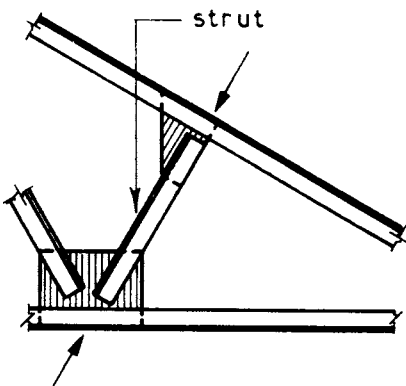

STRUT

structural member which is subjected mainly to compression forces

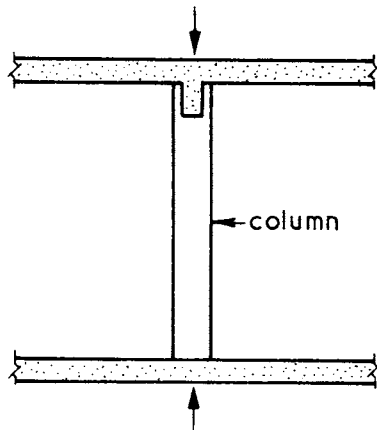

VERTICAL STRUT

usually called a column stanchion or pier

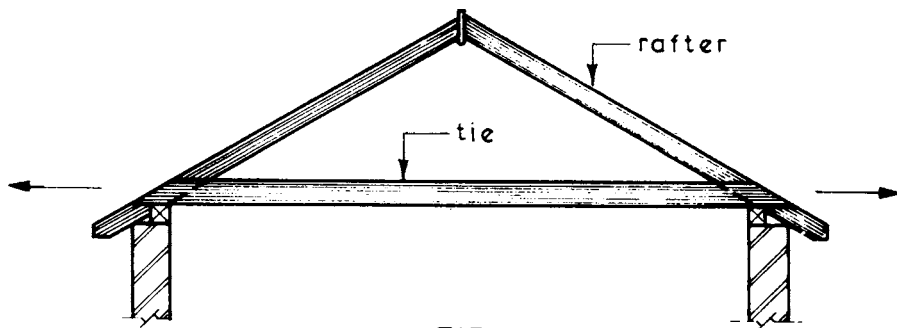

**TIE**

a structural member which is subjected mainly to tension forces

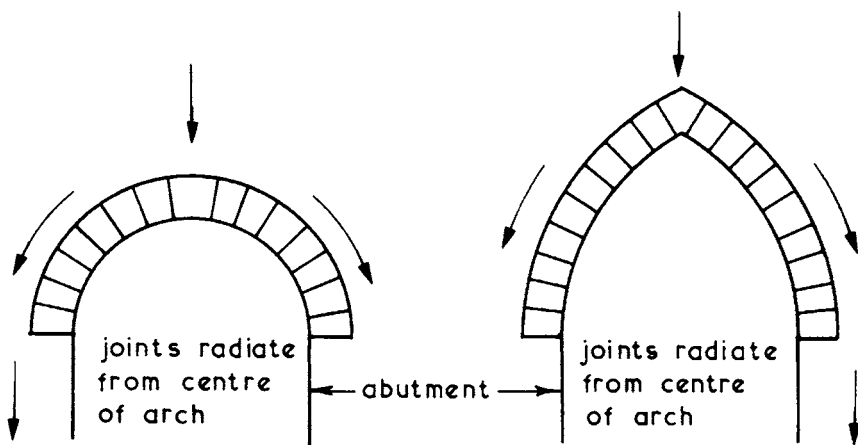

**ARCHES**

loads are transmitted around arch to the abutments

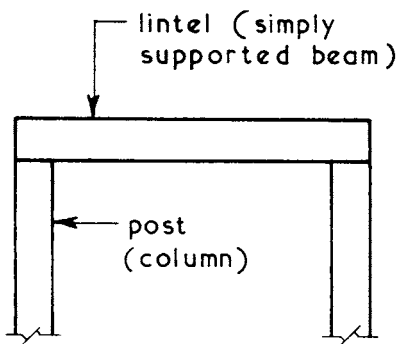

**POST AND LINTEL**

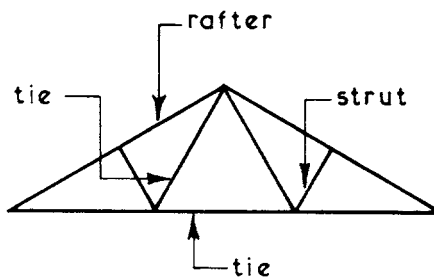

**PLANE FRAME**

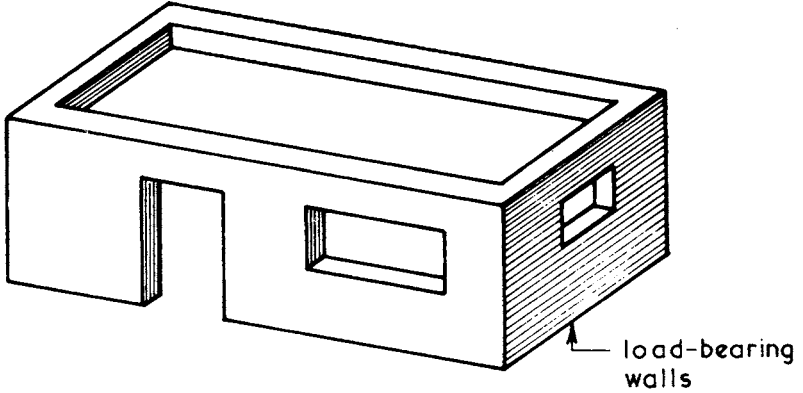

**SOLID CONSTRUCTION**

structurally limited confined usually to buildings of low height and short spans

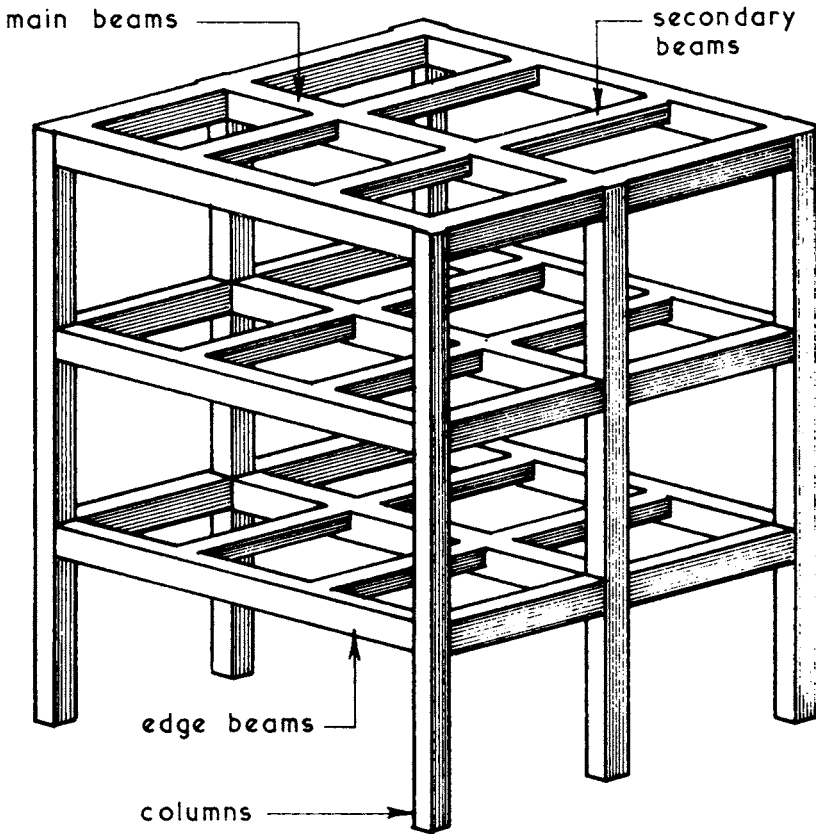

**FRAMED OR SKELETAL CONSTRUCTION**

structure consists of a series of interconnected plates forming structural walls and floors

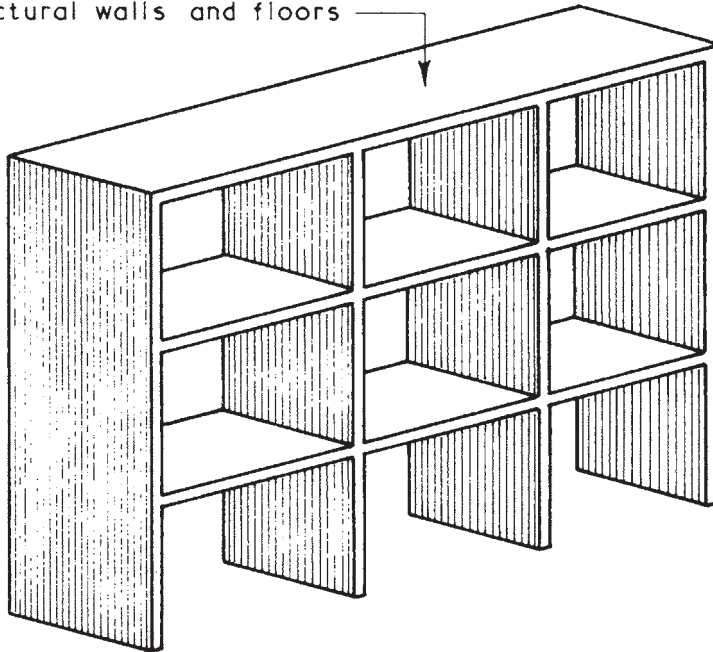

PANEL OR BOX CONSTRUCTION

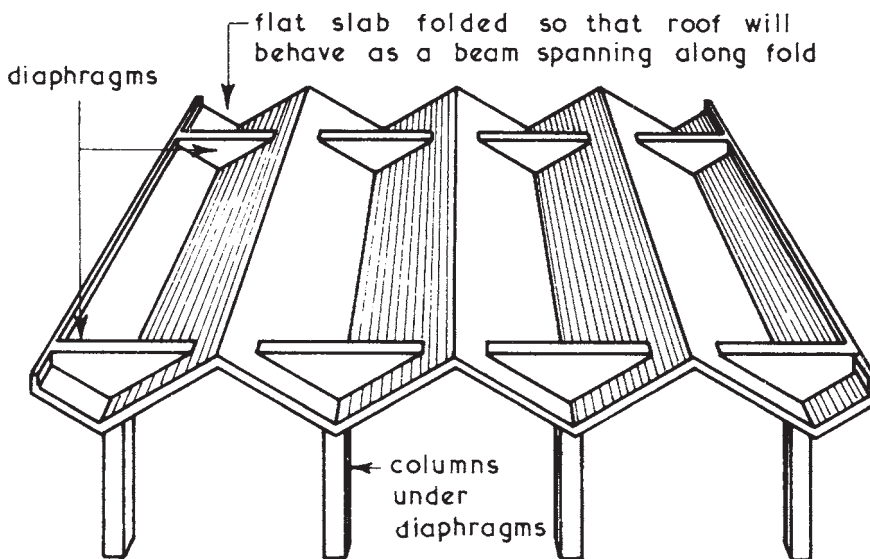

FOLDED PLATE CONSTRUCTION

Shell Roofs ~ these are formed by a structural curved skin covering a given plan shape and area.

Examples ~

double curvature shell  
formed by rotating a  
plain curved shape  
about a vertical axis

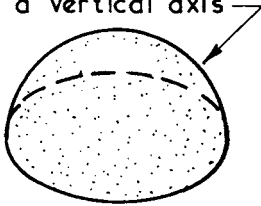

DOME OR ROTATIONAL SHELL

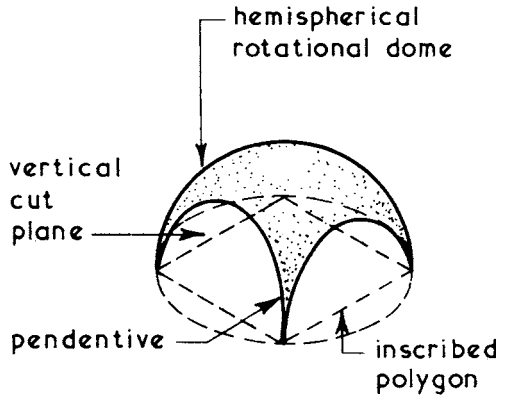

PENDENTIVE DOME

formed by a curved line  
moving over another  
curved line

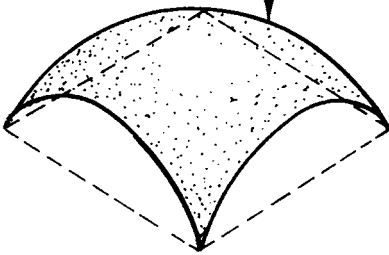

TRANSLATIONAL DOME

cut cylinder giving  
a single curvature  
shell

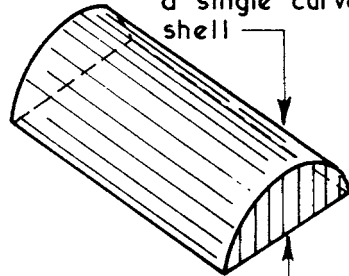

BARREL VAULT

double curvature  
shells

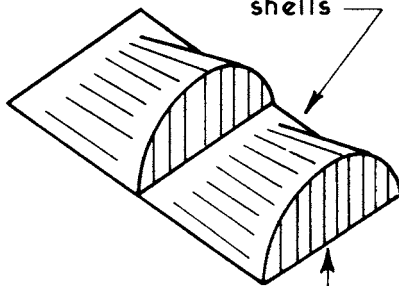

CONOID SHELLS

double curvature  
saddle-shaped  
shell

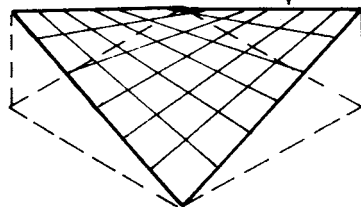

HYPERBOLIC PARABOLOID

a series of interconnected inverted pyramids

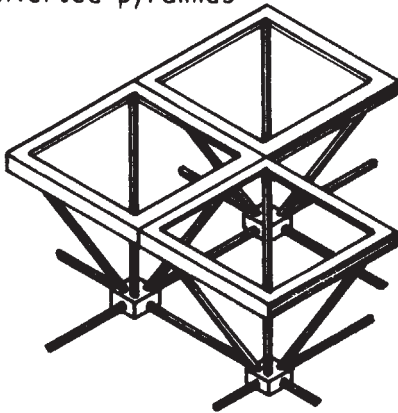

SPACE DECK

a series of interconnected grids

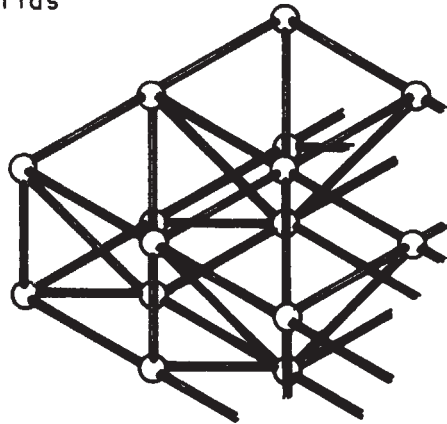

SPACE FRAME

compression arch system

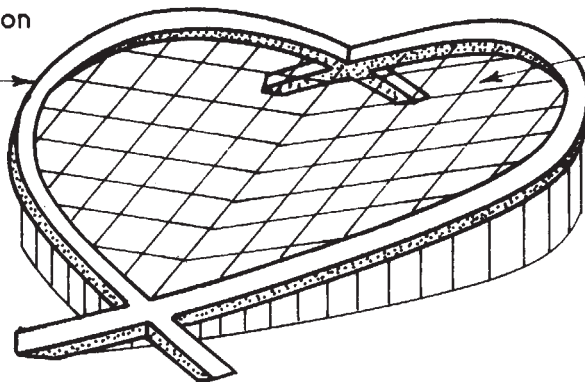

tension cables to support coverings

TENSION CABLE STRUCTURE

net of cables forming tension membrane



coverings supported by membrane

TENSION MEMBRANE STRUCTURE

Substructure ~ can be defined as all structure below the superstructure which in general terms is considered to include all structure below ground level but including the ground floor bed.

Typical Examples ~

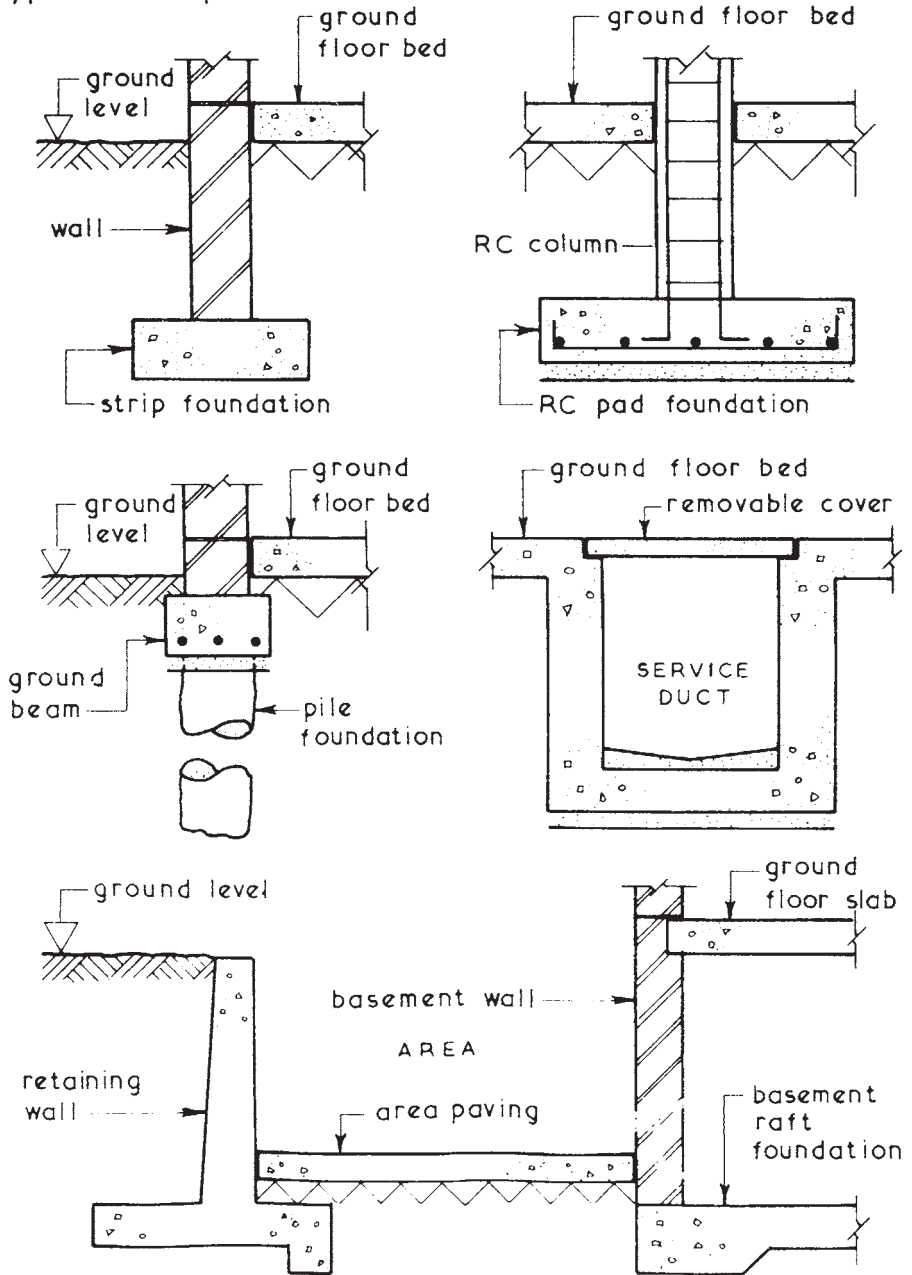



# Superstructure and Primary Elements

Superstructure ~ can be defined as all structure above substructure both internally and externally.

Primary Elements ~ basically components of the building carcass above the substructure excluding secondary elements, finishes, services and fittings.

Typical Examples~

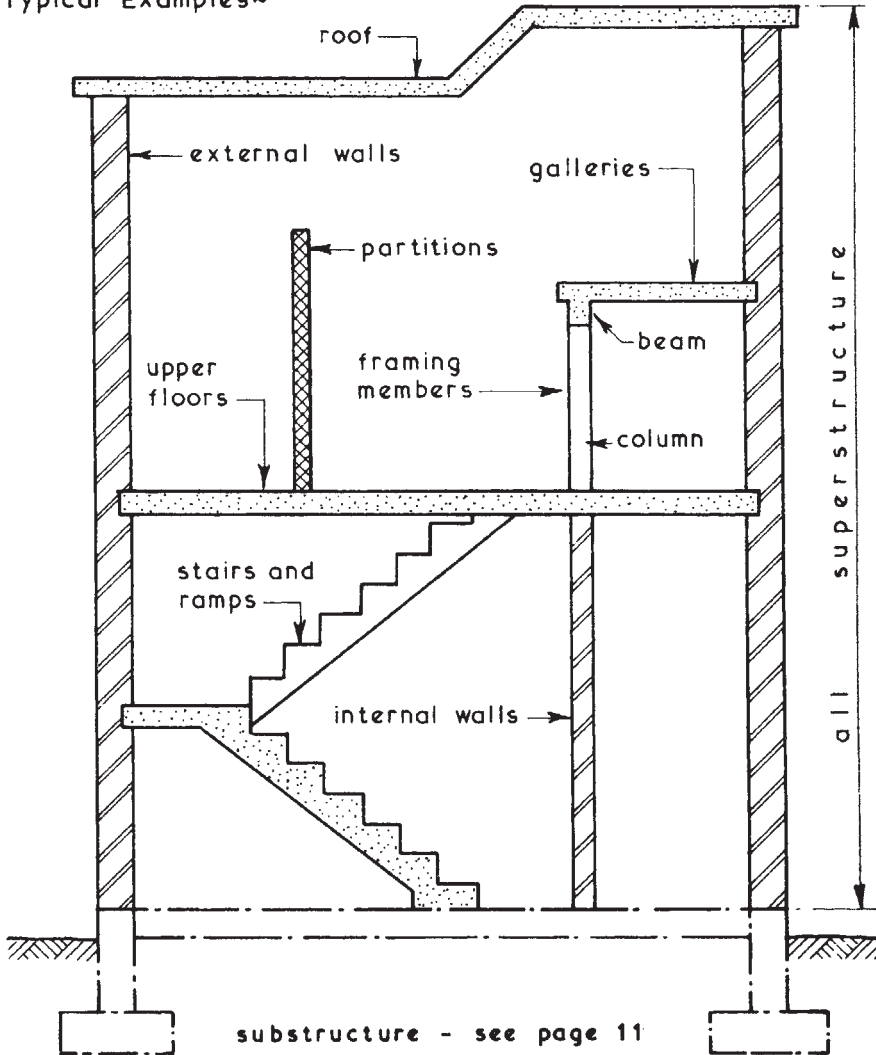

Secondary Elements ~ completion of the structure including completion around and within openings in primary elements.

Typical Examples~

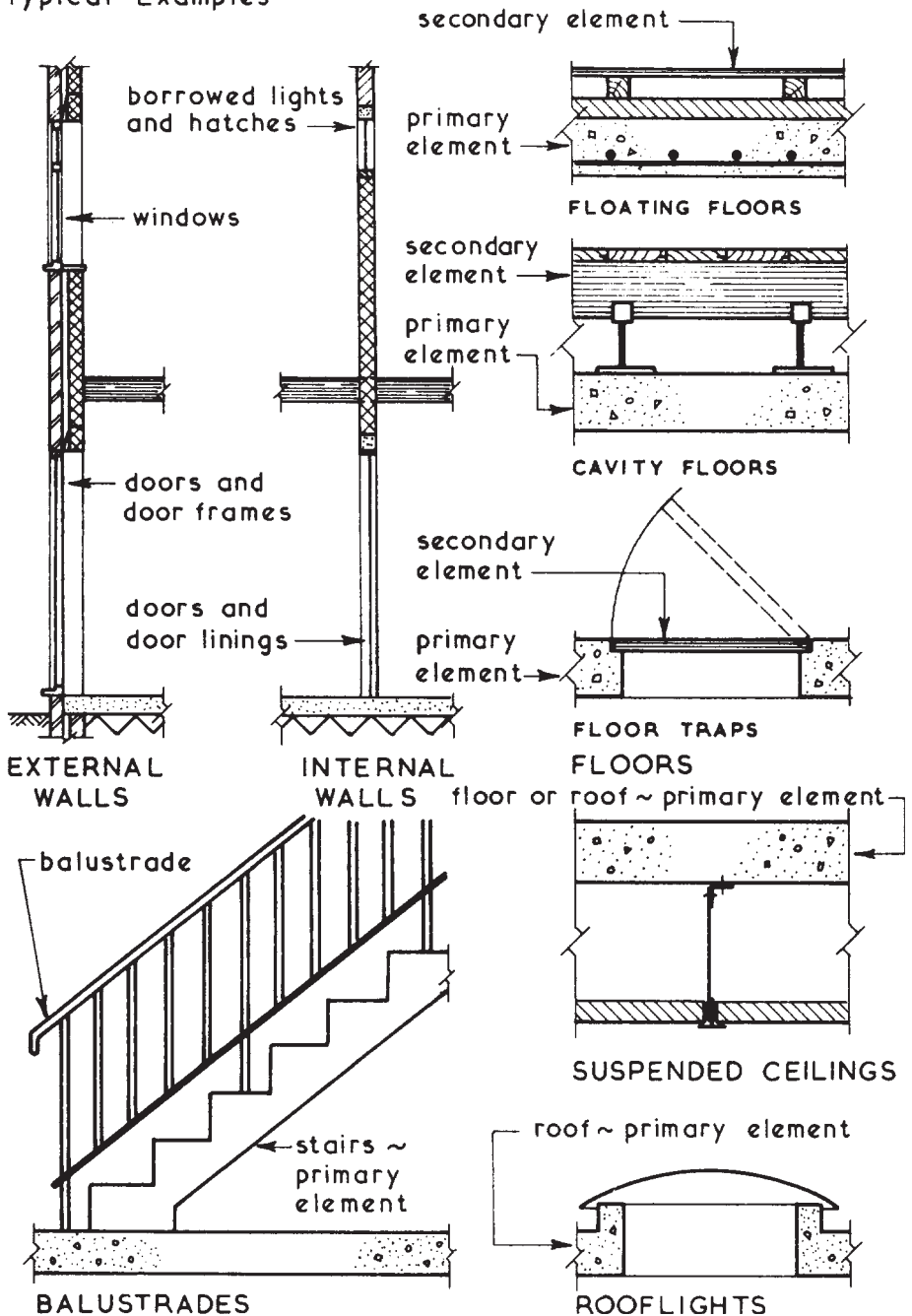

# Finishes

Finish ~ the final surface which can be self-finished as with a trowelled concrete surface or an applied finish such as floor tiles.

Typical Examples ~

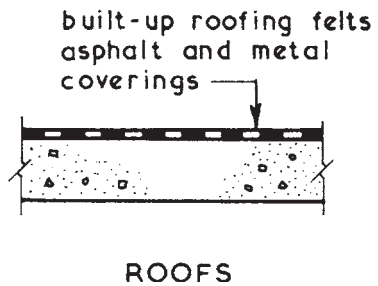
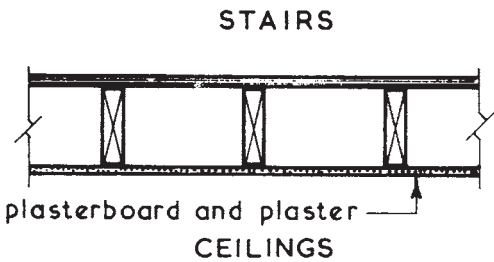
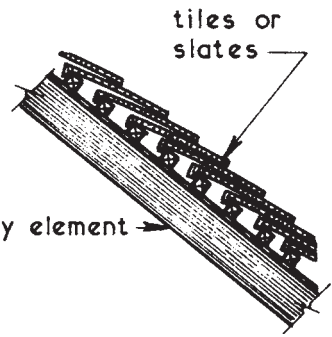
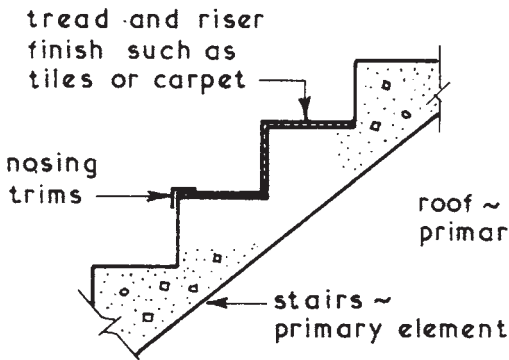
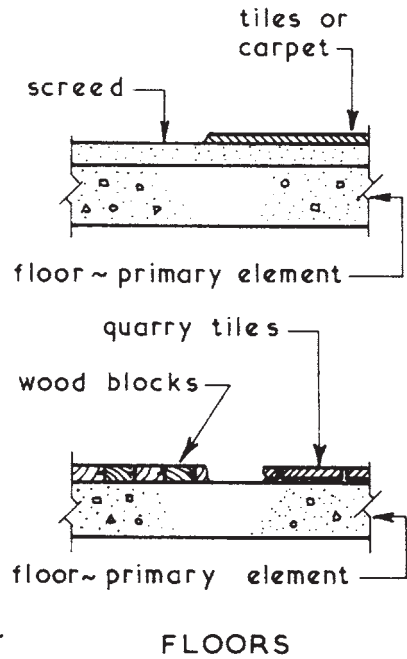
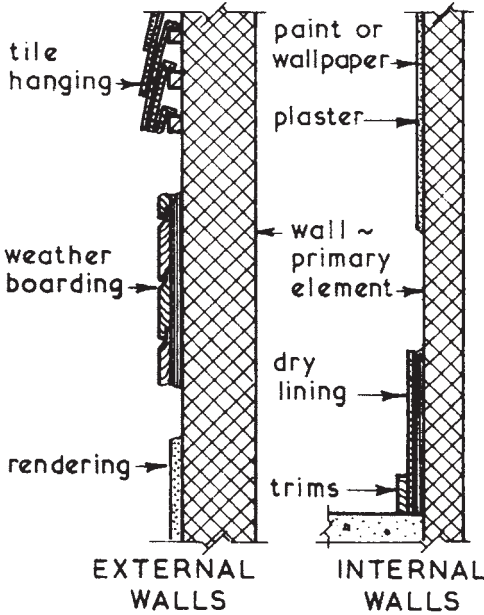

# Structure — Component Parts and Functions

Domestic Structures ~

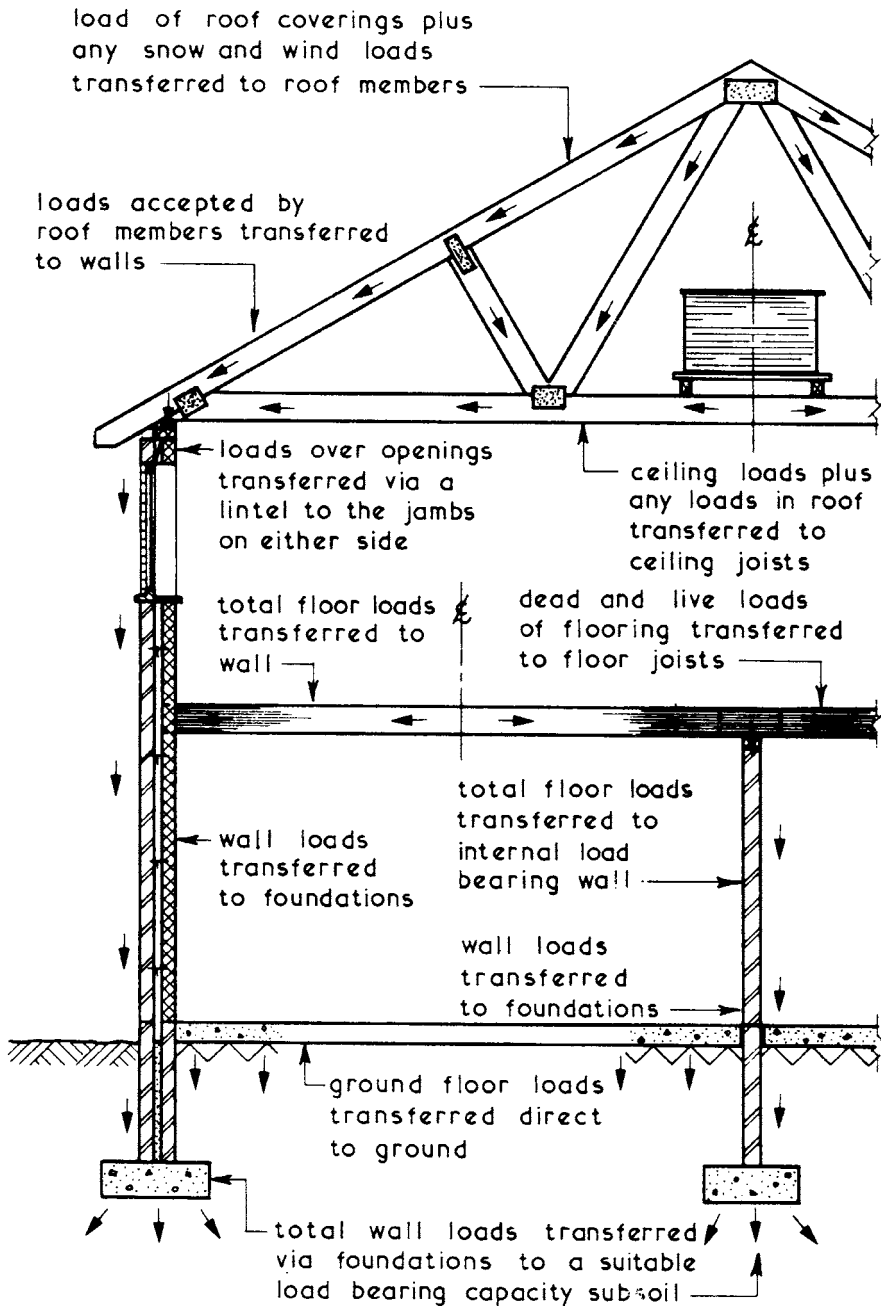

# Structure — Component Parts and Functions

## Framed Structures ~

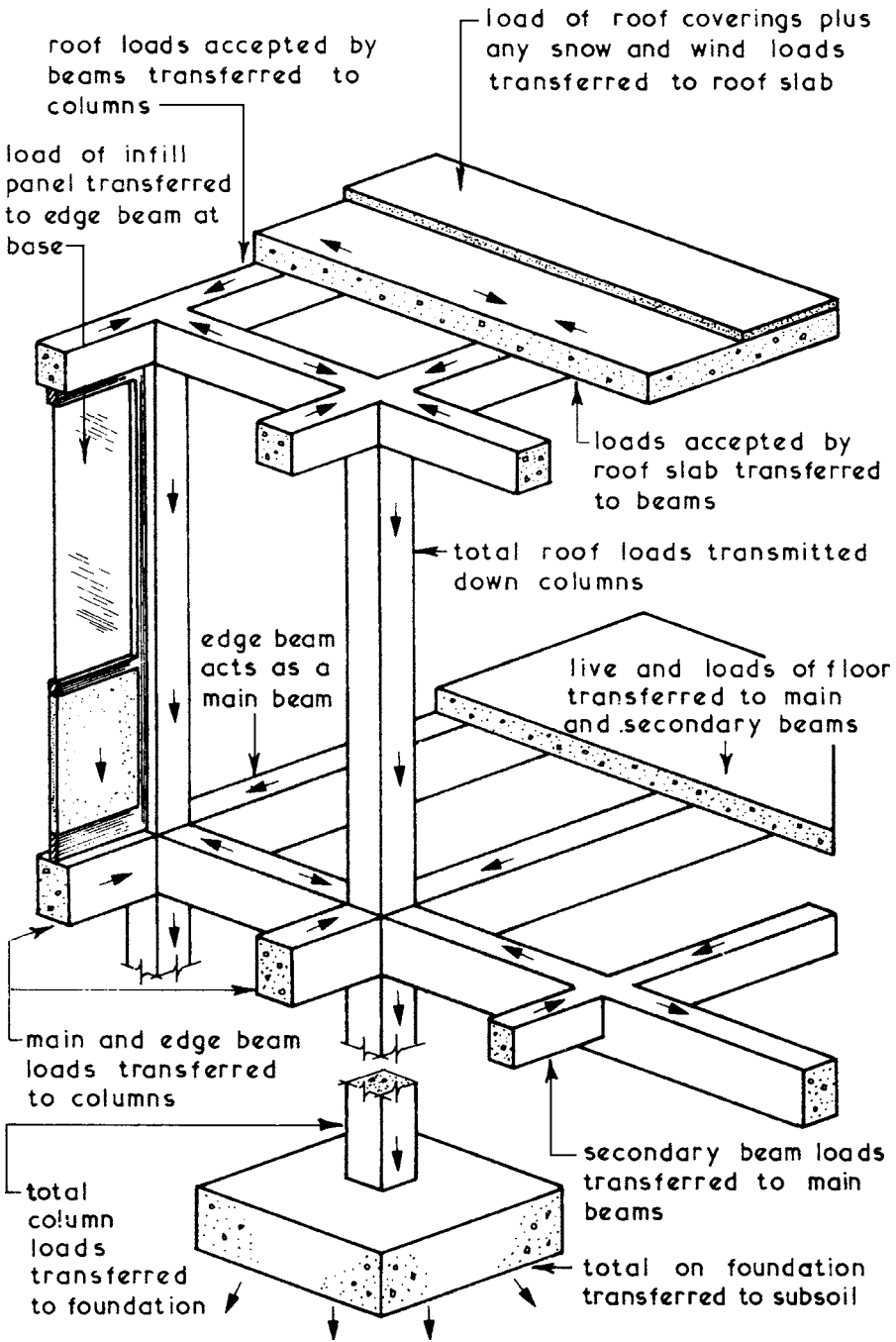

External Envelope ~ consists of the materials and components which form the external shell or enclosure of a building, i.e. walls, ground floor, roof, windows, doors and roof-lights. These may be load bearing or non-load bearing according to the structural form of the building.

Primary Functions ~

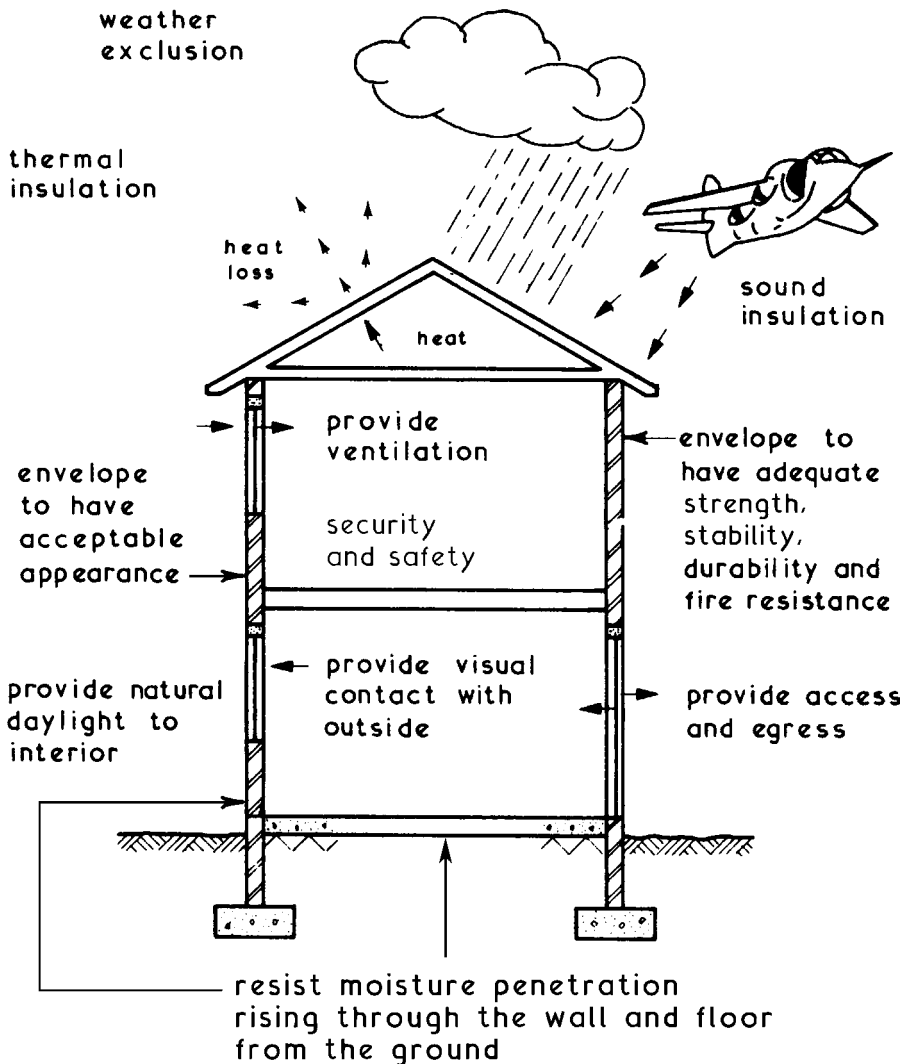

# Internal Separation and Compartmentation

## Dwelling Houses ~

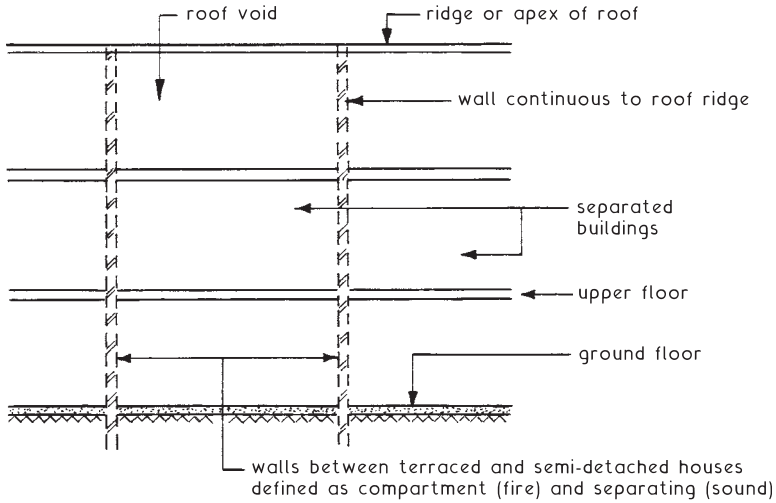

## Flats ~

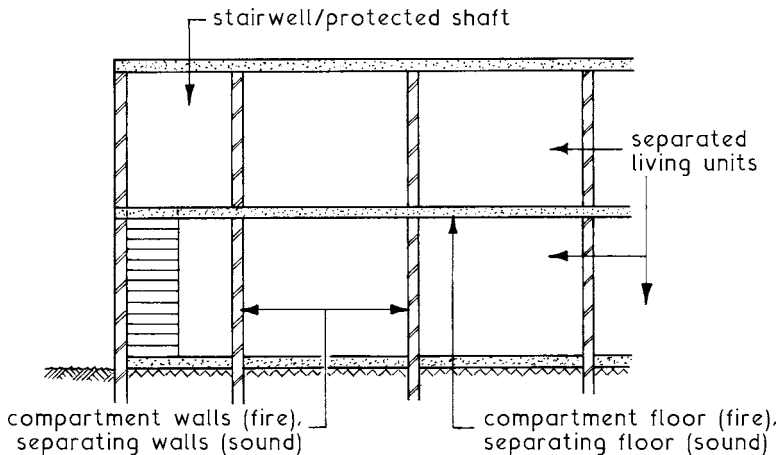

Note: Floors within a maisonette are not required to be "compartment".

For non-residential buildings, compartment size is limited by floor area depending on the building function (purpose group) and height.

Compartment ~ a building or part of a building with walls and floors constructed to contain fire and to prevent it from spreading to another part of the same building or to an adjoining building.

Separating floor/wall ~ element of sound resisting construction between individual living units.

A Building or Construction Site can be considered as a temporary factory employing the necessary resources to successfully fulfil a contract.

Manpower:  
in the form of  
managerial and  
supervisory staff.

Manpower:  
in the form of  
craftsmen and general  
site operatives.

Materials:  
for temporary  
works, access  
provisions,  
security and  
final structure.

Plant:  
from the simple  
hand-held tools  
to large items  
such as tower  
cranes.

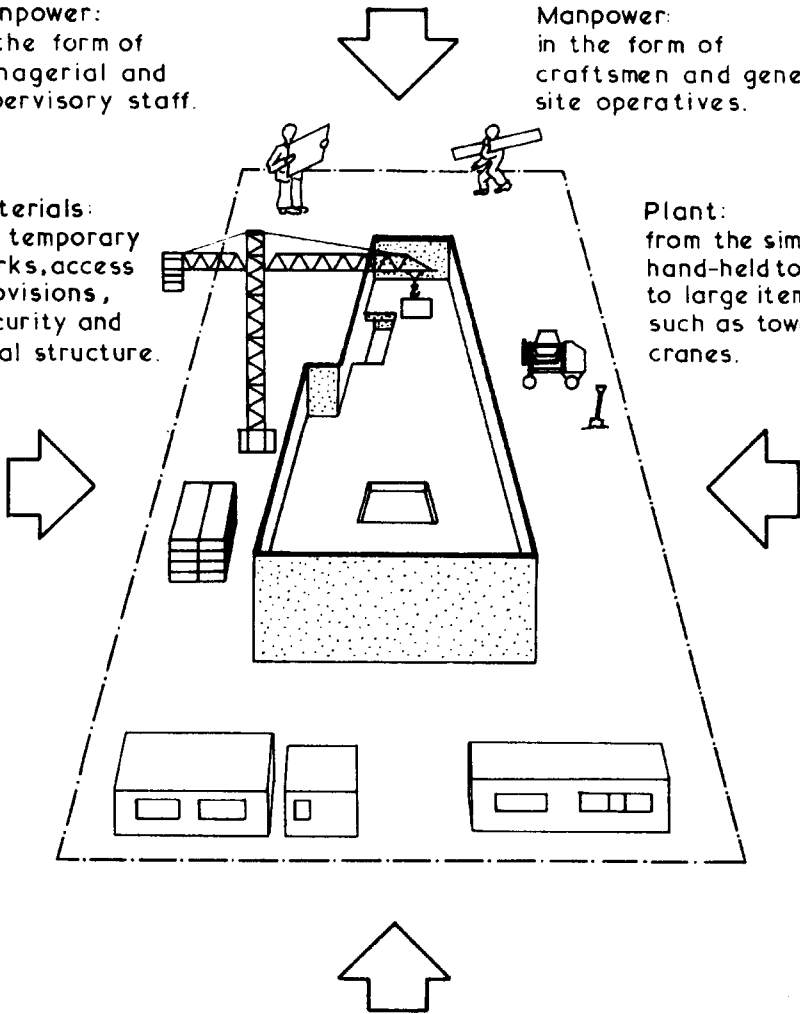

Money:  
in the form of capital investment from the building  
owner to pay for the land, design team fees and a  
building contractor who uses his money to buy materials,  
buy or hire plant and hire labour to enable the  
project to be realised.



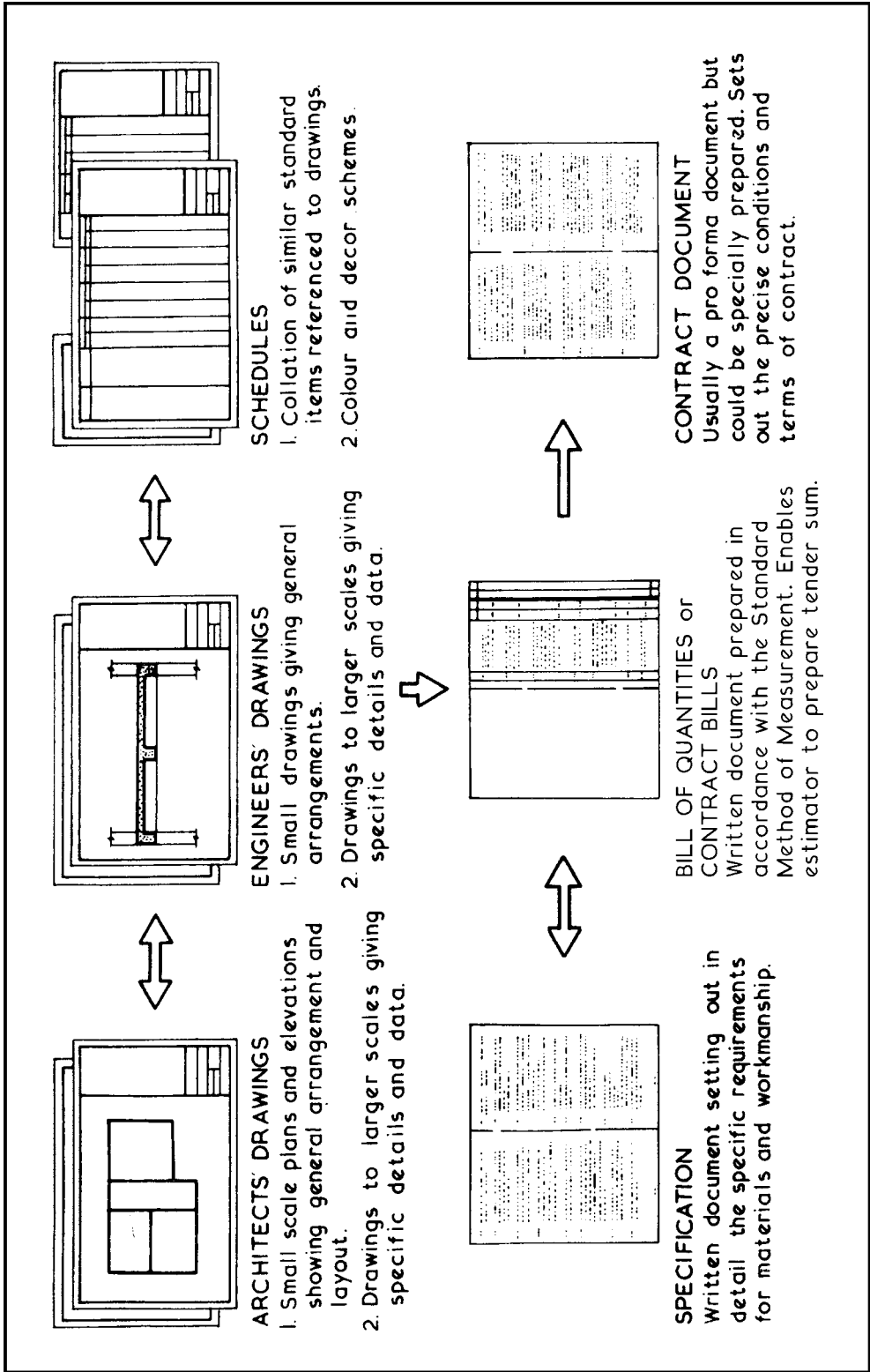

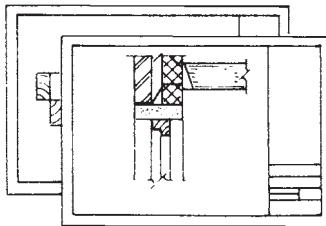
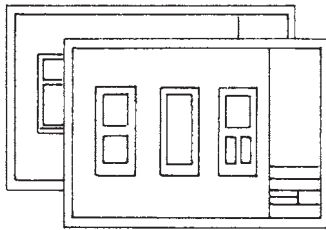
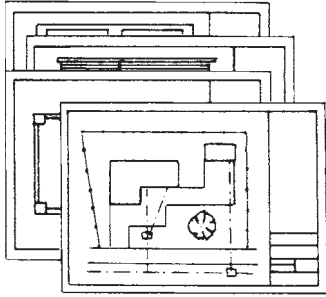
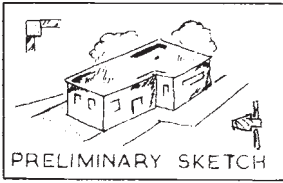

## Location Drawings ~

Site Plans - used to locate site, buildings, define site levels, indicate services to buildings, identify parts of site such as roads, footpaths and boundaries and to give setting-out dimensions for the site and buildings as a whole. Suitable scale not less than 1:2500

Floor Plans - used to identify and set out parts of the building such as rooms, corridors, doors, windows, etc. Suitable scale not less than 1:100

Elevations - used to show external appearance of all faces and to identify doors and windows. Suitable scale not less than 1:100

Sections - used to provide vertical views through the building to show method of construction. Suitable scale not less than 1:50

Component Drawings - used to identify and supply data for components to be supplied by a manufacturer or for components not completely covered by assembly drawings. Suitable scale range 1:100 to 1:1

Assembly Drawings - used to show how items fit together or are assembled to form elements. Suitable scale range 1:20 to 1:5

All drawings should be fully annotated, fully dimensioned and cross-referenced.

Ref. BS EN ISO 7519: Technical drawings. Construction drawings. General principles of presentation for general arrangement and assembly drawings.

## Drawings — Sketches

Sketch ~ this can be defined as a draft or rough outline of an idea; it can be a means of depicting a three-dimensional form in a two-dimensional guise. Sketches can be produced free-hand or using rules and set squares to give basic guidelines.

All sketches should be clear, show all the necessary detail and above all be in the correct proportions.

Sketches can be drawn by observing a solid object or they can be produced from conventional orthographic views but in all cases can usually be successfully drawn by starting with an outline 'box' format giving length, width and height proportions and then building up the sketch within the outline box.

Example ~ Square-based Chimney Pot.

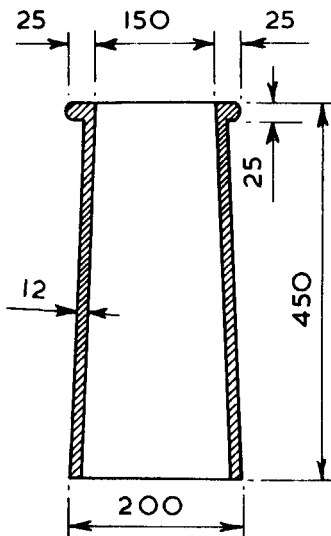

VERTICAL SECTION

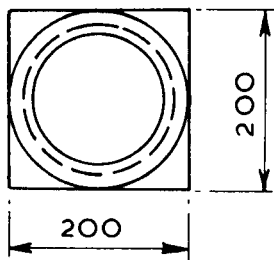

PLAN  
GIVEN DATA

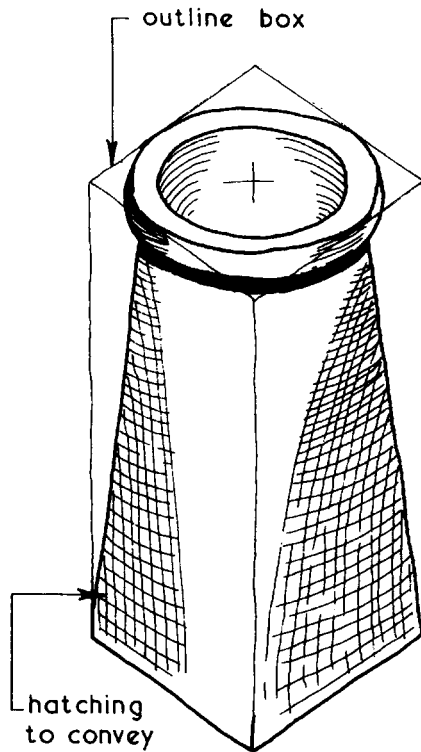

FREE-HAND SKETCH

Orthographic Projection ~ a means of drawing independent views of a solid object on a plane surface.

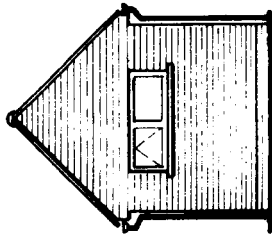

EAST ELEV.

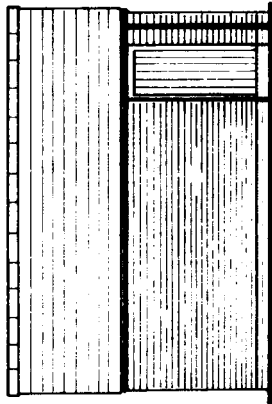

SOUTH ELEVATION

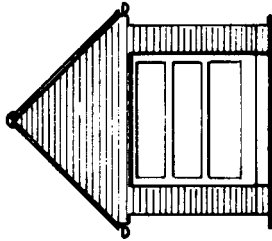

WEST ELEV.

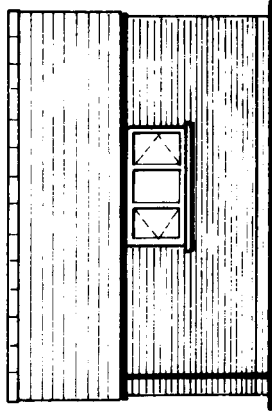

NORTH ELEVATION



Example ~ Small Garage and Workshop

The arrangement of the plan and elevations is known as First Angle Projection and is the recommended method of presenting drawings of building works.

NB. the usual annotation and dimensions found on general drawing have been omitted for clarity.

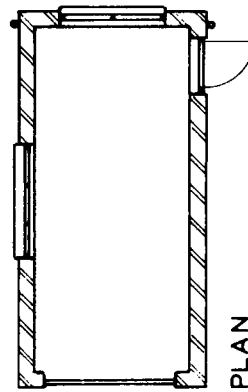

PLAN

## Communicating Information — Isometric Projections

Isometric Projections ~ a pictorial projection of a solid object on a plane surface drawn so that all vertical lines remain vertical and of true scale length, all horizontal lines are drawn at an angle of  $30^\circ$  and are of true scale length; therefore scale measurements can be taken on the vertical and  $30^\circ$  lines but cannot be taken on any other inclined line.

A similar drawing can be produced using an angle of  $45^\circ$  for all horizontal lines and is called an Axonometric Projection.

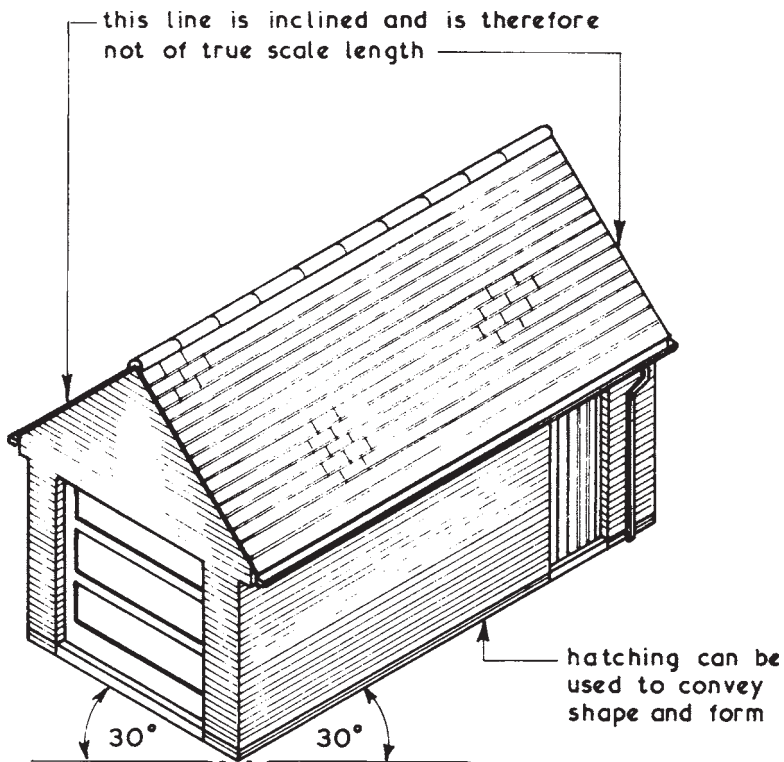

ISOMETRIC PROJECTION SHOWING SOUTH AND WEST ELEVATIONS OF SMALL GARAGE AND WORKSHOP ILLUSTRATED ON PAGE 23

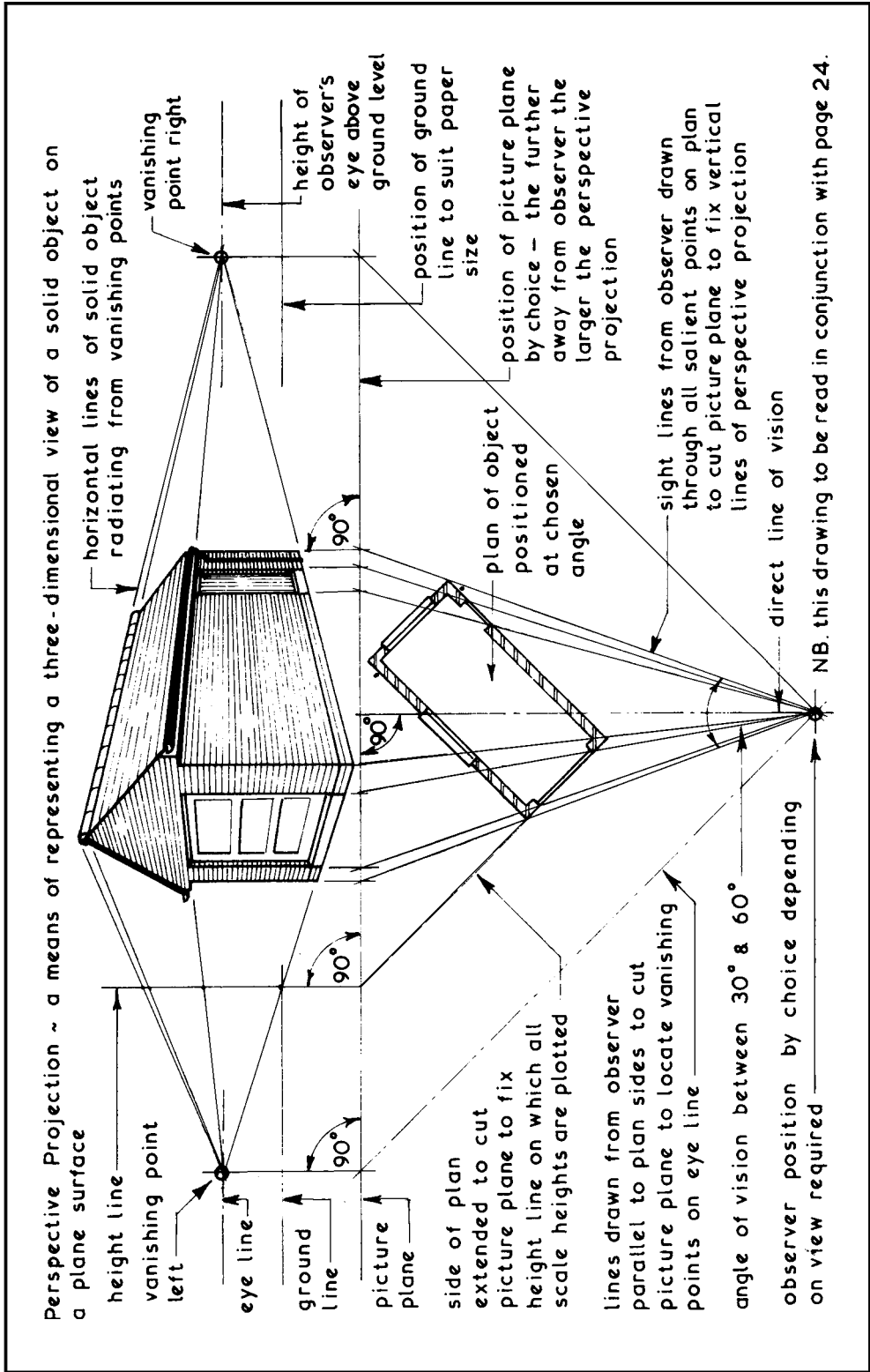

The image contains architectural drawings for a four-bedroom house. On the left side, there are three elevations: the Front Elevation (top), Rear Elevation (middle), and Side Elevation (Right) (bottom). On the right side, there are two floor plans: the Ground Floor Plan (top) and the First Floor Plan (bottom). A title block is located in the upper right corner.

**FRONT ELEVATION**

**REAR ELEVATION**

**SIDE ELEVATION (Right)**

**SIDE ELEVATION (Left)**

**GROUND FLOOR PLAN**

**FIRST FLOOR PLAN**

Title	FOUR BEDROOMED HOUSE	
Scale		Date
Drawing Ref.	RG/HNC, D/10	

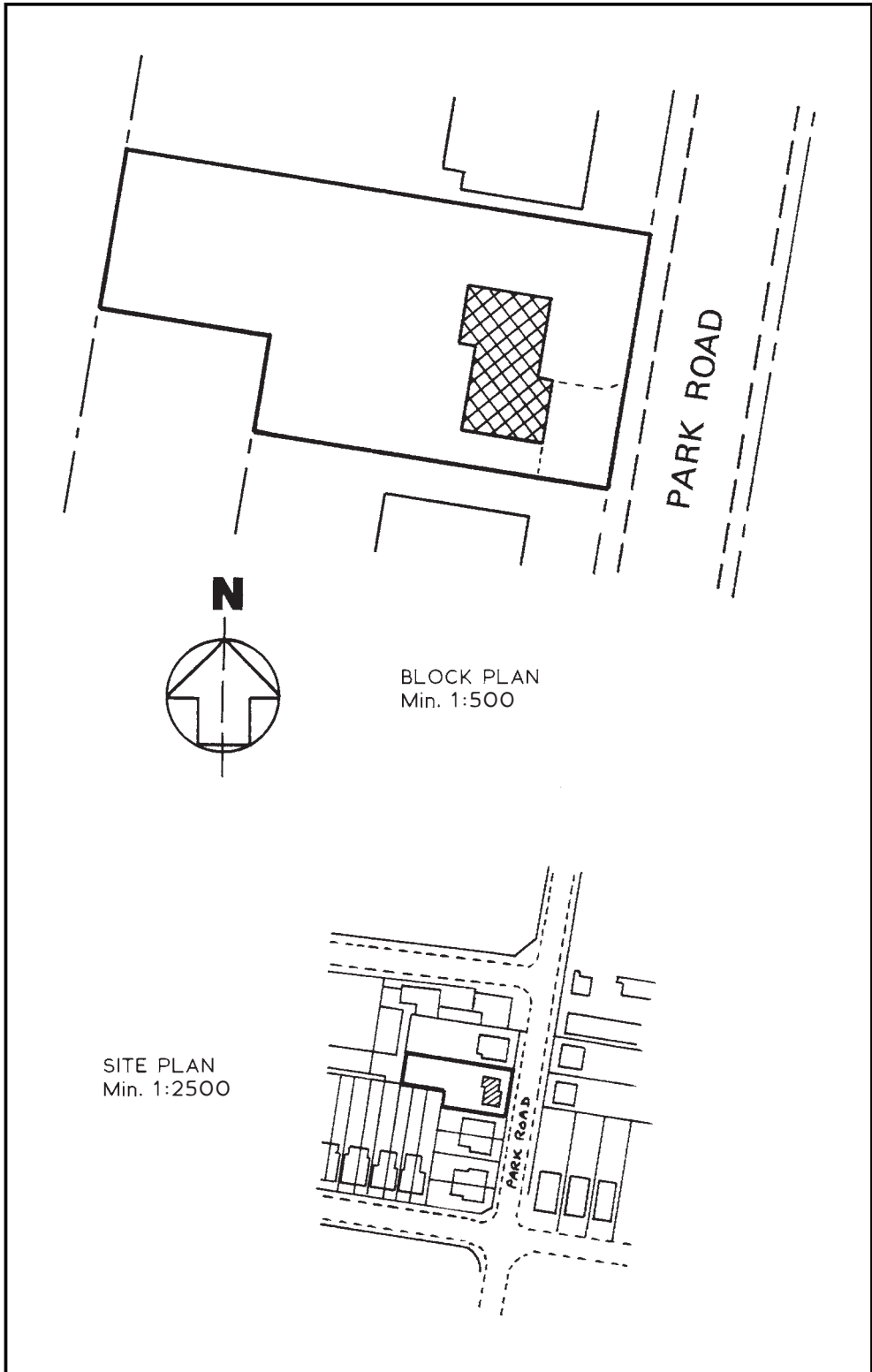



Construction Defects – correct application of materials produced to the recommendations of British, European and International Standards authorities, in accordance with local building regulations, bye-laws and the rules of building guarantee companies, i.e. National House Building Council (NHBC) and MD Insurance Services, should ensure a sound and functional structure. However, these controls can be seriously undermined if the human factor of quality workmanship is not fulfilled. The following guidance is designed to promote quality controls:

BS 8000: Workmanship on building sites.

Building Regulations, Approved Document to support Regulation 7 – materials and workmanship.

No matter how good the materials, the workmanship and supervision, the unforeseen may still affect a building. This may materialise several years after construction. Some examples of these latent defects include: woodworm emerging from untreated timber, electrolytic decomposition of dissimilar metals inadvertently in contact, and chemical decomposition of concrete. Generally, the older a building the more opportunity there is for its components and systems to have deteriorated and malfunctioned. Hence the need for regular inspection and maintenance. The profession of facilities management has evolved for this purpose and is represented by the British Institute of Facilities Management (BIFM).

Property values, repairs and replacements are of sufficient magnitude for potential purchasers to engage the professional services of a building surveyor. Surveyors are usually members of the Royal Institution of Chartered Surveyors (RICS). The extent of survey can vary, depending on a client's requirements. This may be no more than a market valuation to secure financial backing, to a full structural survey incorporating specialist reports on electrical installations, drains, heating systems, etc.

Further reading:

BRE Digest No. 268 – Common defects in low-rise traditional housing. Available from Building Research Establishment Bookshop – [www.brebookshop.com](http://www.brebookshop.com).

Established Procedure – the interested purchaser engages a building surveyor.

UK Government Requirements – the seller to provide an energy performance certificate. This is a fuel use and efficiency appraisal on a numerical scale. See pages 32 and 33.

Survey document preliminaries:

- \* Title and address of property
- \* Client's name, address and contacts
- \* Survey date and time
- \* Property status – freehold, leasehold or commonhold
- \* Occupancy – occupied or vacant. If vacant, source of keys
- \* Extent of survey, e.g. full structural + services reports
- \* Specialists in attendance, e.g. electrician, heating engineer, etc.
- \* Age of property (approx. if very dated or no records)
- \* Disposition of rooms, i.e. number of bedrooms, etc.
- \* Floor plans and elevations if available
- \* Elevation (flooding potential) and orientation (solar effect)
- \* Estate/garden area and disposition if appropriate
- \* Means of access – roads, pedestrian only, rights of way

Survey tools and equipment:

- \* Drawings + estate agent's particulars if available
- \* Notebook and pencil/pen
- \* Binoculars and a camera with flash facility
- \* Tape measure, spirit level and plumb line
- \* Other useful tools, to include small hammer, torch, screwdriver and manhole lifting irons
- \* Moisture meter
- \* Ladders – eaves access and loft access
- \* Sealable bags for taking samples, e.g. wood rot, asbestos, etc.

### Estate and garden:

- \* Location and establishment of boundaries
- \* Fences, gates and hedges – material, condition and suitability
- \* Trees – type and height, proximity to building
- \* Pathways and drives – material and condition
- \* Outbuildings – garages, sheds, greenhouses, barns, etc.
- \* Proximity of water courses

### Roof:

- \* Tile type, treatment at ridge, hips, verge and valleys
- \* Age of covering, repairs, replacements, renewals, general condition, defects and growths
- \* Eaves finish, type and condition
- \* Gutters – material, size, condition, evidence of leakage
- \* Rainwater downpipes as above
- \* Chimney – dpcs, flashings, flaunching, pointing, signs of movement
- \* Flat roofs – materials, repairs, abutments, flashings and drainage

### Walls:

- \* Materials – type of brick, rendering, cladding, etc., condition and evidence of repairs
- \* Solid or cavity construction, if cavity extent of insulation and type
- \* Pointing of masonry, painting of rendering and cladding
- \* Air brick location, function and suitability
- \* Dpc, material and condition, position relative to ground level
- \* Windows and doors, material, signs of rot or damage, original or replacement, frame seal
- \* Settlement – signs of cracking, distortion of window and door frames – specialist report

### Drainage:

A building surveyor may provide a general report on the condition of the drainage and sanitation installation. However, a full test for leakage and determination of self-cleansing and flow conditions to include fibre-optic scope examination is undertaken as a specialist survey.

Roof space:

- \* Access to all parts, construction type - traditional or trussed
- \* Evidence of moisture due to condensation - ventilation at eaves, ridge, etc.
- \* Evidence of water penetration - chimney flashings, abutments and valleys
- \* Insulation - type and quantity
- \* Party wall in semi-detached and terraced dwellings - suitability as fire barrier
- \* Plumbing - adequacy of storage cistern, insulation, overflow function

Floors:

- \* Construction - timber, precast or cast in-situ concrete? Finish condition?
- \* Timber ground floor - evidence of dampness, rot, woodworm, ventilation, dpcs
- \* Timber upper floor stability, i.e. wall fixing, strutting, joist size, woodworm, span and loading

Stairs:

- \* Type of construction and method of fixing - built in-situ or preformed
- \* Soffit, re. fire protection (plasterboard?)
- \* Balustrading - suitability and stability
- \* Safety - adequate screening, balusters, handrail, pitch angle, open tread, tread wear

Finishes:

- \* General décor, i.e. paint and wallpaper condition - damaged, faded
- \* Woodwork/joinery - condition, defects, damage, paintwork
- \* Plaster - ceiling (plasterboard or lath and plaster?) - condition and stability
- \* Plaster - walls - render and plaster or plasterboard, damage and quality of finish
- \* Staining - plumbing leaks (ceiling), moisture penetration (wall openings), rising damp
- \* Fittings and ironmongery - adequacy and function, weather exclusion and security

Supplementary enquiries should determine the extent of additional building work, particularly since the planning threshold of 1948. Check for planning approvals, permitted development and Building Regulation approvals, exemptions and completion certificates.

Services - apart from a cursory inspection to ascertain location and suitability of system controls, these areas are highly specialised and should be surveyed by those appropriately qualified.

## Communicating Information – Energy Performance Certificate

Energy Performance Certificate (EPC) applications include:

- Construction of new buildings.
- Extensions to existing buildings.
- Alterations to existing buildings to provide an increase or a reduction in the number of separate occupancies, e.g. a house conversion into flats or vice versa.
- Refurbishment or modification to include provision or extension of fixed energy consuming building services for hot water, heating, air conditioning or mechanical ventilation (applies to buildings with a floor area exceeding 1000 m<sup>2</sup> but can also be required for smaller buildings depending on specification of installation).
- Part of the marketing particulars when selling or letting a new or existing property.

The above applications relate quite simply to buildings that are roofed, have enclosing walls and use energy consuming appliances to condition the internal space. Some building types are exempted an EPC, these include the following:

- Buildings listed under the Planning (Listed Buildings and Conservation Areas) Act.\*
- Buildings within a conservation area as determined under Section 69 of the Act.\*
- Structures included in the monuments schedule under Section 1 of the Ancient Monuments and Archaeological Areas Act.\*
- Churches and other buildings designated primarily for worship.
- Temporary buildings with less than two years' expected use.
- Industrial buildings, workshops and non-residential agricultural buildings/barns with low demands on energy.
- Detached buildings other than dwellings with usable floor area of less than 50 m<sup>2</sup>.

\* The objective is to preserve the character and appearance of specific buildings that would otherwise be altered or spoilt by applying contemporary energy efficiency requirements.

Ref. The Energy Performance of Buildings (Certificates and Inspections) (England and Wales) Regulations.

An Energy Performance Certificate (EPC) provides a rating for fuel use efficiency in a building. This rating relates to the amount of carbon dioxide (CO<sub>2</sub>) emitted by the energy producing appliances.

Asset rating ~ an estimate of the fuel energy required to meet the needs of a building during normal occupancy. A performance rating based on a building's age, location/exposure, size, glazing system, materials, insulation, general condition, fuel use controls and fixed appliance efficiency, e.g. boiler (SEDBUK rating see page 562). Rating is alphabetical from A to G, A the highest grade for energy efficiency with lowest impact on environmental damage in terms of CO<sub>2</sub> emissions. An EU-type energy rating label is part of the certification documents. It is similar to the example shown on page 566 as applied to windows. The alphabetic rating relates directly to SAP numerical ratings (see page 559) as follows:

EPC asset rating (SAP rating) ~

A (92 – 100)	B (81 – 91)	C (69 – 80)	D (55 – 68)
E (39 – 54)	F (21 – 38)	G (1 – 20)	

Operational rating ~ an alternative to asset rating, using the numerical scale for energy consumed over a period of time. This could be presented monthly or seasonally to indicate varying demands.

CO<sub>2</sub> emission rate calculations for new-build and refurbishment work ~ Before work commences the local building control authority (LA) to be provided with the following for approval:

- Target CO<sub>2</sub> emission rate by calculation (TER).
- Dwelling CO<sub>2</sub> emission rate by calculation and design (DER).
- Building design specification relative to calculated CO<sub>2</sub> emissions.

After (within five days of completion), LA to be provided with certification confirming:

- Target CO<sub>2</sub> emissions.
- Calculated CO<sub>2</sub> emissions as constructed.
- Confirmation that the building design specification is adhered to. If not, details of variations to be provided.

Note: TER and DER energy performance requirements are expressed in mass of CO<sub>2</sub> in units of kg per m<sup>2</sup> floor area per year. See also pages 567 and 568.

### EPC content:

Address and location of the building assessed.  
Activity/function of the building, e.g. dwelling house.  
Date of construction, approximate if very old.  
Construction, e.g. solid walls, cavity walls, etc.  
Materials of construction.  
Heat energy source, system type and fuel used.  
Electrical energy source, lighting and power provision.  
Energy efficiency asset rating.  
Environmental impact rating (CO<sub>2</sub> emissions).  
Recommendations for improvements.  
Date of issue (valid 10 years unless significant changes occur).  
Reference/registration number.  
Assessor's name, accreditation number and scheme number.

EPC assessor/surveyor ~ an appropriately qualified energy assessment member of an accredited scheme approved by the Secretary of State for the Department for Communities and Local Government (DCLG), as defined in the Energy Performance of Buildings (Certificates and Inspections) (England and Wales) Regulations. Within five days of work completion, the assessor must provide the building owner with an EPC and the local authority to be informed of the details of the EPC reference as entered in the register maintained under Regulation 31.

Recommendations for improvements ~ in addition to an energy assessment survey and rating, the assessor is required to provide a report identifying areas that could improve the energy performance of a building. Examples may include cost-effective recommendations for cavity wall insulation, increased insulation in the roof space, provision of a central-heating room temperature control thermostat, double/secondary glazing, etc. These recommendations to include a cost analysis of capital expenditure relative to potential savings over time and enhanced asset rating that the building could attain.

### Related refs.:

Building Regulation 29 – Declaration of giving an EPC.  
Building Regulations Approved Document L.  
Standard Assessment Procedure.  
Energy Performance of Buildings Directive – 2010/31/EU.

Dwelling type .....  
 Assessment date .....  
 Certificate date .....

Ref. No. ....  
 Type of assessment .....  
 Total floor area .....

This certificate can be used to:

- Compare the energy efficiency with other properties/dwellings.
- Determine the potential economies of energy saving installations.

Estimated energy costs over 3 years: £3,750  
 Energy saving potential over 3 years: £1,330

Estimated energy costs of this dwelling over 3 years:

	Current cost	Potential cost	Potential savings
Lighting	£380	£190	£190
Heating	£2,820	£1,980	£840
Hot water	£550	£250	£300
Totals	£3,750	£2,420	£1,330

Figures do not include costs of running subsidiary appliances such as TV, fridge, cooker, etc.

Energy Efficiency Rating:

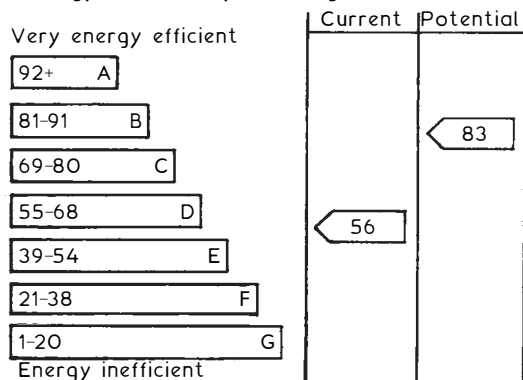

Diagram shows current efficiency rating.

Higher the rating, the lower the fuel costs.

Potential rating includes recommendations indicated below.

Average rating for a dwelling in England and Wales is band D (60).

Recommended measures:

	Indicative capital cost	Typical savings over 3 years
Increase loft insulation	£150 - £350	£125
Solar photovoltaic panels	£9,000 - £14,000	£700
Low energy lighting throughout	£120	£150



A method statement precedes preparation of the project programme and contains the detail necessary for construction of each element of a building. It is prepared from information contained in the contract documents – see page 20. It also functions as a brief for site staff and operatives in sequencing activities, indicating resource requirements and determining the duration of each element of construction. It complements construction programming by providing a detailed analysis of each activity.

A typical example for foundation excavation could take the following format:

Activity	Quantity	Method	Output/hour	Labour	Plant	Days
Strip site for excavation	300m <sup>2</sup>	Exc. to reduced level over construction area – JCB-4CX face shovel/loader. Topsoil retained on site.	50 m <sup>2</sup> /hr	Exc. driver +2 labourers	JCB-4CX backhoe/loader	0.75
Excavate for foundations	60m <sup>3</sup>	Excavate foundation trench to required depth – JCB-4CX backhoe. Surplus spoil removed from site.	15 m <sup>3</sup> /hr	Exc. driver +2 labourers. Truck driver	JCB-4CX backhoe/loader. Tipper truck	0.50

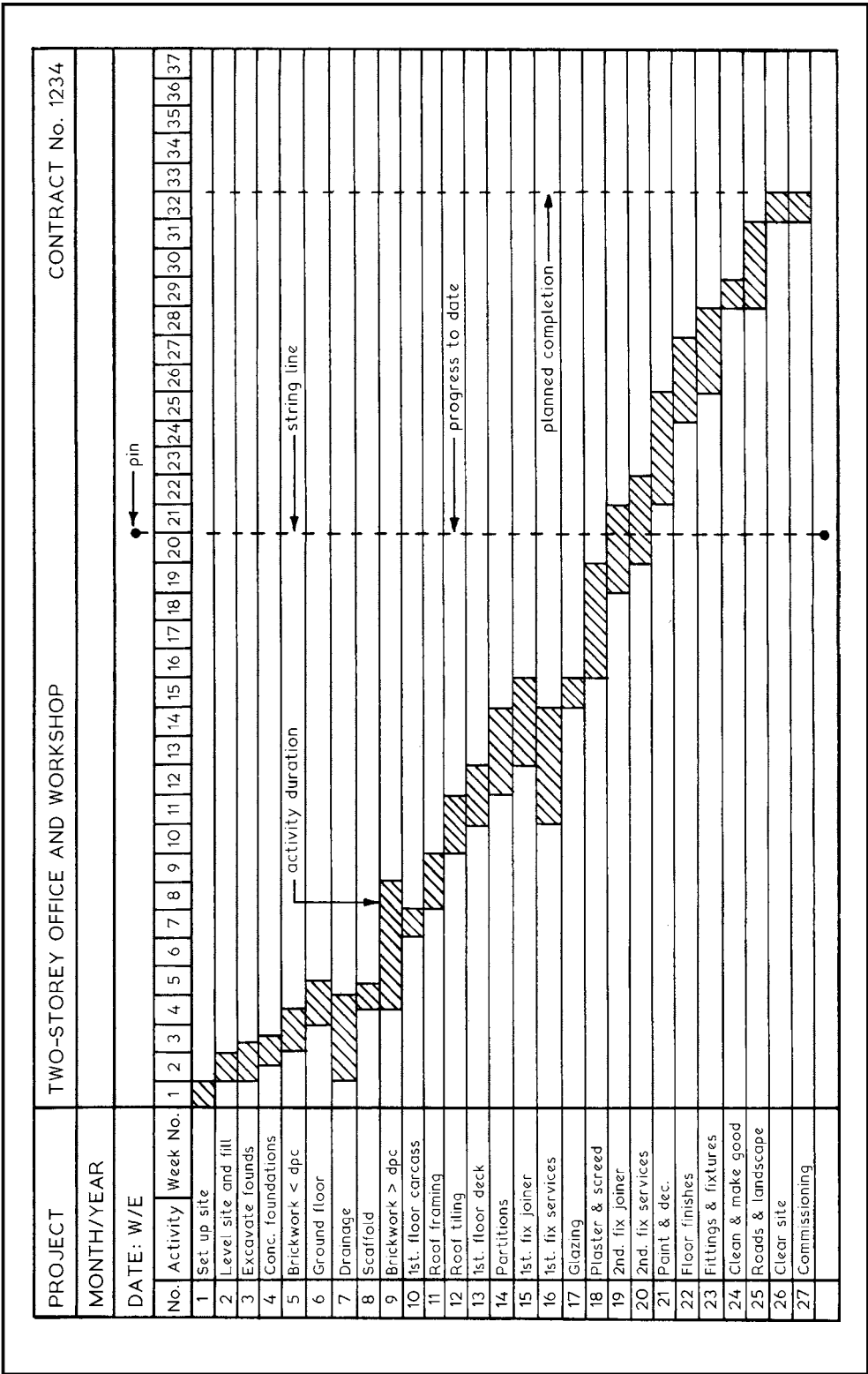

## Typical Weights of Building Materials

Material	Weight (kg/m <sup>2</sup> )
<b>BRICKS, BLOCKS and PAVING -</b>	
Clay brickwork - 102.5 mm	
low density	205
medium density	221
high density	238
Calcium silicate brickwork - 102.5 mm	205
Concrete blockwork, aerated	78
..... lightweight aggregate	129
Concrete flagstones (50 mm)	115
Glass blocks (100 mm thick) 150 × 150	98
.....200 × 200	83
<b>ROOFING -</b>	
Slates - see page 518	
Thatching (300 mm thick)	40.00
Tiles - plain clay	63.50
.. - plain concrete	93.00
.. single lap, concrete	49.00
Tile battens (50 × 25) and felt underlay	7.70
Bituminous felt underlay	1.00
Bituminous felt, sanded topcoat	2.70
3 layers bituminous felt	4.80
HD/PE breather membrane underlay	0.20
<b>SHEET MATERIALS -</b>	
Aluminium (0.9 mm)	2.50
Copper (0.9 mm)	4.88
Cork board (standard) per 25 mm thickness	4.33
..... (compressed) .....	9.65
Hardboard (3.2 mm)	3.40
Glass (3 mm)	7.30
Lead (1.25 mm)	14.17
... (3 mm)	34.02
Particle board/chipboard (12 mm)	9.26
..... (22 mm)	16.82
Planking, softwood strip flooring (ex 25 mm)	11.20
..... hardwood .....	16.10
Plasterboard (9.5 mm)	8.30
..... (12.5 mm)	11.00
..... (19 mm)	17.00
Plywood per 25 mm	15.00
PVC floor tiling (2.5 mm)	3.90
Strawboard (25 mm)	9.80

## Typical Weights of Building Materials and Densities

Material	Weight (kg/m <sup>2</sup> )
Weatherboarding (20 mm)	7.68
Woodwool (25 mm)	14.50
<b>INSULATION</b>	
Glass fibre thermal (100 mm)	2.00
..... acoustic .....	4.00
<b>APPLIED MATERIALS -</b>	
Asphalt (18 mm)	42
Plaster, 2 coat work	22
<b>STRUCTURAL TIMBER:</b>	
Rafters and joists (100 × 50 @ 400 c/c)	5.87
Floor joists (225 × 50 @ 400 c/c)	14.93
Densities:	
Material	Approx. density (kg/m <sup>3</sup> )
Cement	1440
Concrete (aerated)	640
..... (broken brick)	2000
..... (natural aggregates)	2300
..... (no-fines)	1760
..... (reinforced)	2400
<b>Metals:</b>	
Aluminium	2710
Brass	8500
Copper	8930
Lead	11325
Steel	7860
Tin	7300
Zinc	7140
Timber (softwood/pine)	480 (average)
..... (hardwood, e.g. maple, teak, oak)	720 .....
Water	1000

## Typical Imposed Floor Loads

Structural design of floors will be satisfied for most situations by using the minimum figures given for uniformly distributed loading (UDL). These figures provide for static loading and for the dynamics of occupancy. The minimum figures given for concentrated or point loading can be used where these produce greater stresses.

Application	UDL (kN/m <sup>2</sup> )	Concentrated (kN)
Dwellings ~		
Communal areas	1.5	1.4
Bedrooms	1.5	1.8
Bathroom/WC	2.0	1.8
Balconies (use by one family)	1.5	1.4
Commercial/Industrial ~		
Hotel/motel bedrooms	2.0	1.8
Communal kitchen	3.0	4.5
Offices and general work areas	2.5	2.7
Kitchens/laundries/laboratories	3.0	4.5
Factories and workshops	5.0	4.5
Balconies – guest houses	3.0	1.5/m run at outer edge
Balconies – communal areas in flats	3.0	1.5/m run at outer edge
Balconies – hotels/motels	4.0	1.5/m run at outer edge
Warehousing/Storage ~		
General use for static items	2.0	1.8
Reading areas/libraries	4.0	4.5
General use, stacked items	2.4/m height	7.0
Filing areas	5.0	4.5
Paper storage	4.0/m height	9.0
Plant rooms	7.5	4.5
Book storage	2.4/m height (min. 6.5)	7.0

See also:

BS EN 1991-1-1: Densities, self-weight, imposed loads for buildings.

BS EN 1991-1-3: Snow loads.

BS EN 1991-1-4: Wind actions.

Drawings ~ these are the principal means of communication between the designer, the builder and other parties to a contract.

Drawings should therefore be clear, accurate, contain all the necessary information and be capable of being easily read.

Design practices have their own established symbols and notations for graphical communication. Some of these are shown on this and the next three pages. Other guidance can be found in BS EN ISOs 4157 and 7519.

**Typical Examples~**

———— outlines

———— dimension and hatching lines

----- hidden detail

----- drain and pipe lines

----- centre lines

⌈————⌋ modular and coordinating dimension lines

⌈————⌋ work size dimension lines

⑫----- controlling and grid lines

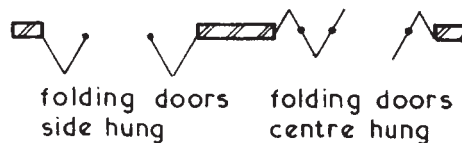
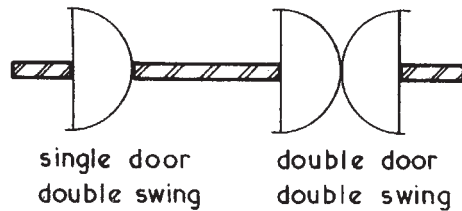
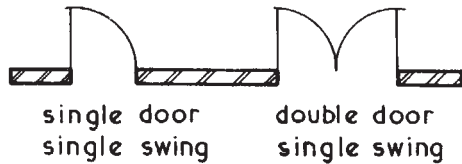

**LINES**

**DOORS**

# Drawings — Hatchings, Symbols and Notations

Hatchings ~ the main objective is to differentiate between the materials being used thus enabling rapid recognition and location. Whichever hatchings are chosen they must be used consistently throughout the whole set of drawings. In large areas it is not always necessary to hatch the whole area.

Symbols ~ these are graphical representations and should wherever possible be drawn to scale but above all they must be consistent for the whole set of drawings and clearly drawn.

## Typical Examples ~



soil



hardcore

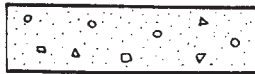

mass concrete



reinforced concrete



brickwork



blockwork



stonework



unwrot timber



wrot (wrought) or planed timber

MATERIALS

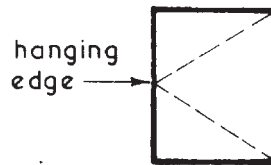

hanging edge

side hung opening out



top hung opening out



bottom hung opening in

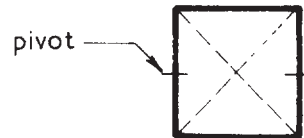





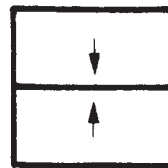







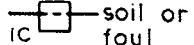
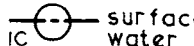



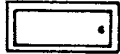

pivot

horizontal pivot

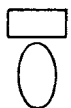
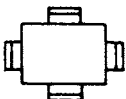

double hung or sliding sash  
WINDOWS

Name	Symbol	Name	Symbol
Rainwater pipe		Distribution board	
Gully		Electricity meter	
Inspection chambers	 	Switched socket outlet	
Boiler		Switch	
Sink		Two-way switch	
Bath		Pendant switch	
Wash basin		Filament lamp	
Shower unit		Fluorescent lamp	
Urinal	  stall      bowl	Bed	
Water closet		Table and chairs	

TYPICAL COMPONENT, FITMENT AND ELECTRICAL SYMBOLS



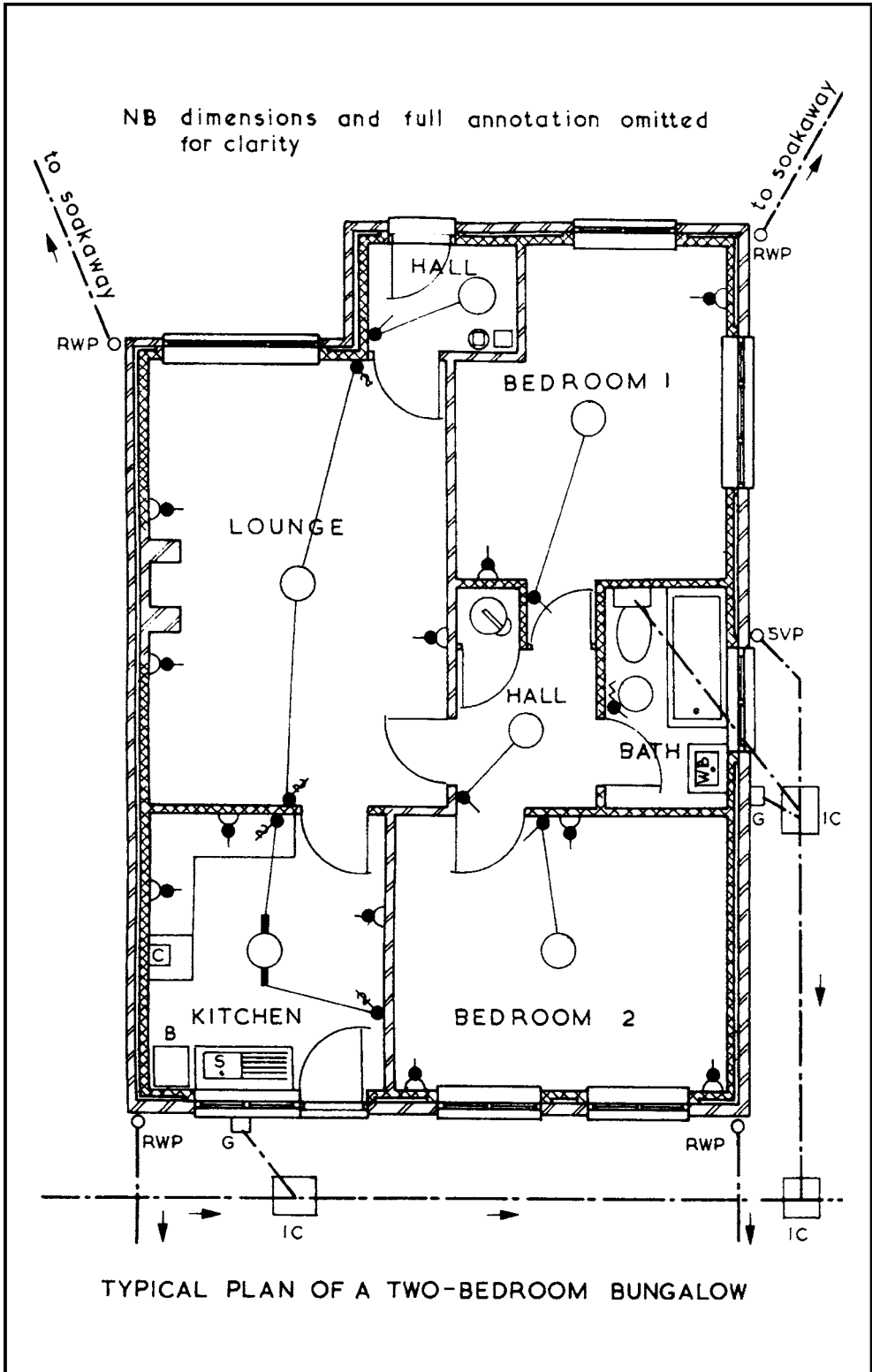

Principal legislation ~

Town & Country Planning Act 1990 and Planning Act 2008 – Effect control over volume of development, appearance and layout of buildings.

Public Health Acts 1936 to 1961 – Limit development with regard to emission of noise, pollution and public nuisance.

Highways Act 1980 – Determines layout and construction of roads and pavements.

Building Act 1984 – Effects the Building Regulations 2010, which enforce minimum material and design standards.

Civic Amenities Act 1967 – Establishes conservation areas, providing local authorities with greater control of development.

Town and Country Amenities Act 1974 – Local authorities empowered to prevent demolition of buildings and tree felling.

Procedure ~

Outline Planning Application – This is necessary for permission to develop a proposed site. The application should contain:

An application form describing the work.

A site plan showing adjacent roads and buildings (1:2500).

A block plan showing the plot, access and siting (1:500).

A certificate of land ownership.

Detail or Full Planning Application – This follows outline permission and is also used for proposed alterations to existing buildings.

It should contain: details of the proposal, to include trees, materials, drainage and any demolition.

Site and block plans (as above). A certificate of land ownership.

Building drawings showing elevations, sections, plans, material specifications, access, landscaping, boundaries and relationship with adjacent properties (1:100).

Permitted Developments – House extensions may be exempt from formal application. Conditions vary depending on house position relative to its plot and whether detached or attached. See next two pages.

Note: Most developments are subject to Building Regulation approval. Some exemptions are shown on page 69.

Certificates of ownership – Article 7 of the Town & Country Planning (General Development Procedure) Order 1995:

Cert. A – States the applicant is sole site freeholder (page 51).

Cert. B – States the applicant is part freeholder or prospective purchaser and all owners of the site know of the application (page 51).

Cert. C – As Cert. B, but the applicant is only able to ascertain some of the other landowners.

Cert. D – As Cert. B, but the applicant cannot ascertain any owners of the site other than him/herself.

## Planning Application Exemptions

Permitted development ~ on 1 October 2008 regulations were introduced to simplify the planning approval process for relatively small-scale construction work to existing houses. The approval, known as permitted development, to be undertaken without the cost and time-consuming process of formalising a detailed/full planning application to the local planning authority (LPA). Before October 2008 permitted development existed as a nominal volume percentage increase over the house size without much clarification beyond that. The new regulations, entitled The Town and Country Planning (General Permitted Development) (Amendment) (No.2) (England) Order 2008, will reduce the number of former planning applications by about a quarter. There are limitations for permitted development that relate to the position and size of a house as it stood on 1 July 1948 or when first built if later. Proposals for property enlargement beyond these constraints must be submitted for formal planning approval.

Application ~ permitted development applies specifically to extensions and alterations to houses, but not flats. This does not necessarily include all houses. Houses in conservation areas and those listed for historical interest may be excluded. The LPA should be consulted for clarification on all proposals, as planning departments will interpret the "Order" with regard to their locality. Exemption from the formal planning process does not include exemption from Building Regulation approval. Most extensions and some alterations will still require this (see pages 61 to 70).

Lawful Development Certificate (LDC) ~ this is an option that can be sought from the LPA. It is an alternative to submitting a full planning application where there is any doubt or ambiguity about work that would qualify for permitted development. It is not intended as a planning permit, but it is documented proof that the building created by extending or altering a house is lawful. Even if alterations are clearly defined by permitted development, the option of obtaining a LDC may be considered worthwhile to satisfy any queries if prospective future purchasers of the property require the work substantiated. As well as establishing the lawfulness of proposed work, an application for a LDC can be retrospective.

Ref. Town and Country Planning Act 1990, Sections 191 and 192.

Limits and conditions, subject to LPA interpretation:

- Maximum of half the area of land around the house taken up with extension or other buildings (as the house stood on 1 July 1948 or when first built if later).
- No extension beyond the principal elevation or a side elevation that fronts a highway.
- Single-storey extension:
  - Attached house, max. 3m beyond the rear wall.
  - Detached house, max. 4m beyond the rear wall.
- Additional storeys to a rear extension, max. 3m in depth.
- Two-storey extension not closer than 7m to the rear boundary.
- Over one storey high, roof pitch to match existing.
- Max. eaves height of 3m if the extension is within 2m of a boundary.
- Max. eaves and ridge height no higher than existing.
- Side elevation extension max. 4m height. Width not greater than half that of the original house (see above, re. 1948).
- Materials to match existing.
- No verandas, balconies or raised platforms (> 300mm high).
- No chimney, flue or discharge stack installation, alteration or replacement if it exceeds the highest part of the roof by 1 m.
- Upper floor extension with side-facing windows obscure glazed.
- Upper floor side-facing extension windows to be non-opening or if openable the opening parts at least 1.7 m above floor.
- In conservation areas, subject to LPA agreement, single-storey rear extension only. No exterior cladding and no side extensions.
- No enlargement, additions or alterations to a roof to extend beyond the plane of slope of the existing roof which forms the principal elevation of the house and fronts a highway. An exception of up to 150mm perpendicular to the plane may be permitted.
- Roof space extension:
  - Terraced house, 40m<sup>3</sup> max. increase over the existing roof space.
  - Semi-detached or detached house, 50m<sup>3</sup> max. increase over the existing roof space.
- Porch outside of an external door:
  - External ground area not to exceed 3m<sup>2</sup>.
  - Height above the ground not to exceed 3m.
  - Greater than 2m from a boundary with a highway.
- Driveway or paving exceeding 5m<sup>2</sup> to be of gravel, porous asphalt or any other material that will allow the drainage of water.

# PLANNING APPLICATION

Use this form to apply for Planning Permission for:-  
 • an Extension                      • a High Wall or Fence  
 • a Loft Conversion                • a Garage or Outbuilding  
 • a New or Altered Access        • a Satellite Dish

Please return:-  
 • 6 copies of the Form  
 • 6 copies of the Plans  
 • a Certificate under Article 7  
 • the correct fee

APPLICATION No \_\_\_\_\_  
 DATE RECEIVED \_\_\_\_\_

**1. NAME AND ADDRESS OF APPLICANT**

\_\_\_\_\_

\_\_\_\_\_

\_\_\_\_\_

\_\_\_\_\_

Post Code \_\_\_\_\_

Tel. No. \_\_\_\_\_

**2. NAME AND ADDRESS OF AGENT (If Used)**

\_\_\_\_\_

\_\_\_\_\_

\_\_\_\_\_

\_\_\_\_\_

Post Code \_\_\_\_\_

Tel. No. \_\_\_\_\_

**3. ADDRESS OF PROPERTY TO BE ALTERED OR EXTENDED**

\_\_\_\_\_

\_\_\_\_\_

\_\_\_\_\_

\_\_\_\_\_

**4. OWNERSHIP**  
 Please indicate applicants interest in the property and complete the appropriate Certificate under Article 7.

Freeholder                          Other   

Leasholder   

Purchaser    

**5. BRIEF DESCRIPTION OF WORKS (include any demolition work)**

\_\_\_\_\_

\_\_\_\_\_

\_\_\_\_\_

**6. DESCRIPTION OF EXTERNAL MATERIALS**

\_\_\_\_\_

\_\_\_\_\_

\_\_\_\_\_

**7. ACCESS AND PARKING**  
 Will your proposal affect? Please tick appropriate boxes

Vehicular Access                      Yes     No

A Public Right of Way                Yes     No

Existing Parking                        Yes     No

**8. DRAINAGE**

a. Please indicate method of Surface Water Disposal

\_\_\_\_\_

\_\_\_\_\_

b. Please indicate method of Foul Water Disposal  
 Please tick one box

Mains Sewer                          Septic Tank   

Cesspit                                         Other           

**9. TREES**  
 Does the proposal involve the felling of any trees?  
 Please tick box                      Yes     No

If yes, please show details on plans

**10. PLEASE SIGN AND DATE THIS FORM BEFORE SUBMITTING**  
 I/We hereby apply for Full Planning Permission for the development described above and shown on the accompanying plans.

Signed \_\_\_\_\_ Date \_\_\_\_\_

Date \_\_\_\_\_

On behalf of (if agent) \_\_\_\_\_

Use this form to apply for **Planning Permission** for:-

- Outline Permission**
- Full Permission**
- Approval of Reserved Matters**
- Renewal of Temporary Permission**
- Change of Use**

**Please return:-**

- \* 6 copies of the Form
- \* 6 copies of the Plans
- \* a Certificate under Article 7
- \* the correct fee

DATE RECEIVED

DATE VALID

**1. NAME AND ADDRESS OF APPLICANT**

\_\_\_\_\_  
 \_\_\_\_\_  
 \_\_\_\_\_  
 \_\_\_\_\_

Post Code \_\_\_\_\_

Day Tel. No. \_\_\_\_\_ Fax No. \_\_\_\_\_

Email: \_\_\_\_\_

**2. NAME AND ADDRESS OF AGENT (If Used)**

\_\_\_\_\_  
 \_\_\_\_\_  
 \_\_\_\_\_  
 \_\_\_\_\_

Post Code \_\_\_\_\_

Tel. No. \_\_\_\_\_ Fax No. \_\_\_\_\_

Email: \_\_\_\_\_

**3. ADDRESS OR LOCATION OF LAND TO WHICH APPLICATION RELATES**

\_\_\_\_\_  
 \_\_\_\_\_  
 \_\_\_\_\_

State Site Area \_\_\_\_\_ Hectares

This must be shown edged in Red on the site plan

**4. OWNERSHIP**

Please indicate applicants interest in the property and complete the appropriate Certificate under Article 7.

- Freeholder  Other   
 Leaseholder  Purchaser

Any adjoining land owned or controlled and not part of application must be edged Blue on the site plan

**5. WHAT ARE YOU APPLYING FOR?** Please tick one box and then answer relevant questions.

- Outline Planning Permission** Which of the following are to be considered?  
 Siting  Design  Appearance  Access  Landscaping
- Full Planning Permission/Change of Use**
- Approval of Reserved Matters following Outline Permission.**

O/P No. \_\_\_\_\_ Date \_\_\_\_\_ No. of Condition this application refers to: \_\_\_\_\_

- Continuance of Use without complying with a condition of previous permission**

P/P No. \_\_\_\_\_ Date \_\_\_\_\_ No. of Condition this application relates to: \_\_\_\_\_

- Permission for Retention of works.**

Date of use of land or when buildings or works were constructed: \_\_\_\_\_ Length of temporary permission: \_\_\_\_\_

Is the use temporary or permanent? \_\_\_\_\_ No. of previous temporary permission if applicable: \_\_\_\_\_

**6. BRIEF DESCRIPTION OF PROPOSED DEVELOPMENT**

Please indicate the purpose for which the land or buildings are to be used. \_\_\_\_\_

\_\_\_\_\_

# Planning Application — New Build (2)

**7. NEW RESIDENTIAL DEVELOPMENTS.** Please answer the following if appropriate:

What type of building is proposed? \_\_\_\_\_

No. of dwellings: \_\_\_\_\_ No. of storeys: \_\_\_\_\_ No. of habitable rooms: \_\_\_\_\_

No. of garages: \_\_\_\_\_ No. of parking spaces: \_\_\_\_\_ Total grass area of all buildings: \_\_\_\_\_

How will surface water be disposed of? \_\_\_\_\_

How will foul sewage be dealt with? \_\_\_\_\_

## 8. ACCESS

Does the proposed development involve any of the following? Please tick the appropriate boxes.

New access to a highway	<input type="checkbox"/> Pedestrian	<input type="checkbox"/> Vehicular
Alteration of an existing highway	<input type="checkbox"/> Pedestrian	<input type="checkbox"/> Vehicular
The felling of any trees	<input type="checkbox"/> Yes	<input type="checkbox"/> No

If you answer Yes to any of the above, they should be clearly indicated on all plans submitted.

## 9. BUILDING DETAIL

Please give details of all external materials to be used, if you are submitting them at this stage for approval.

\_\_\_\_\_  
\_\_\_\_\_

List any samples that are being submitted for consideration. \_\_\_\_\_

\_\_\_\_\_

## 10. LISTED BUILDINGS OR CONSERVATION AREA

Are any listed buildings to be demolished or altered?  Yes  No

If Yes, then Listed Building Consent will be required and a separate application should be submitted.

Are any non-listed buildings within a Conservation Area to be demolished?  Yes  No

If Yes, then Conservation Area consent will be required to demolish. Again, a separate application should be submitted.

## 11. NOTES

A special Planning Application Form should be completed for all applications involving Industrial, Warehousing, Storage, or Shopping development.

An appropriate Certificate must accompany this application unless you are seeking approval to Reserved Matters.

A separate application for Building Regulation approval is also required.

Separate applications may also be required if the proposals relate to a listed building or non-listed building within a Conservation Area.

## 12. PLEASE SIGN AND DATE THIS FORM BEFORE SUBMITTING

I/We hereby apply for Planning Permission for the development described above and shown on the accompanying plans.

Signed \_\_\_\_\_

TOWN AND COUNTRY PLANNING ACT

TOWN AND COUNTRY PLANNING (General Development Procedure) ORDER  
Certificates under Article 7 of the Order

**CERTIFICATE A For Freehold Owner (or his/her Agent)**

I hereby certify that:-

1. No person other than the applicant was an owner of any part of the land to which the application relates at the beginning of the period of 21 days before the date of the accompanying application.
2. **\*Either (i)** None of the land to which the application relates constitutes or forms part of an agricultural holding;  
**\*or (ii)** \*(I have) (the applicant has) given the requisite notice to every person other than \*(myself) (himself) (herself) who, 21 days before the date of the application, was a tenant of any agricultural holding any part of which was comprised in the land to which the application relates, viz:-

Name and Address of Tenant.....

.....

..... Signed ..... Date.....

Date of Service of Notice..... \*On Behalf of .....

**CERTIFICATE B For Part Freehold Owner or Prospective Purchaser (or his/her Agent) able to ascertain all the owners of the land**

I hereby certify that:-

1. \*(I have) (the applicant has) given the requisite notice to all persons other than (myself) (the applicant) who, 21 days before the date of the accompanying application were owners of any part of the land to which the application relates, viz:-

Name and Address of Owner .....

.....

..... Date of Service of Notice .....

2. **\*Either (i)** None of the land to which the application relates constitutes or forms part of an agricultural holding;  
**\*or (ii)** \*(I have) (the applicant has) given the requisite notice to every person other than \*(myself) (himself) (herself) who, 21 days before the date of the application, was a tenant of any agricultural holding any part of which was comprised in the land to which the application relates, viz:-

Name and Address of Tenant.....

.....

..... Signed ..... Date.....



## Modular Coordination

Modular Coordination ~ a module can be defined as a basic dimension which could, for example, form the basis of a planning grid in terms of multiples and submultiples of the standard module.

Typical Modular Coordinated Planning Grid ~

Let  $M$  = the standard module

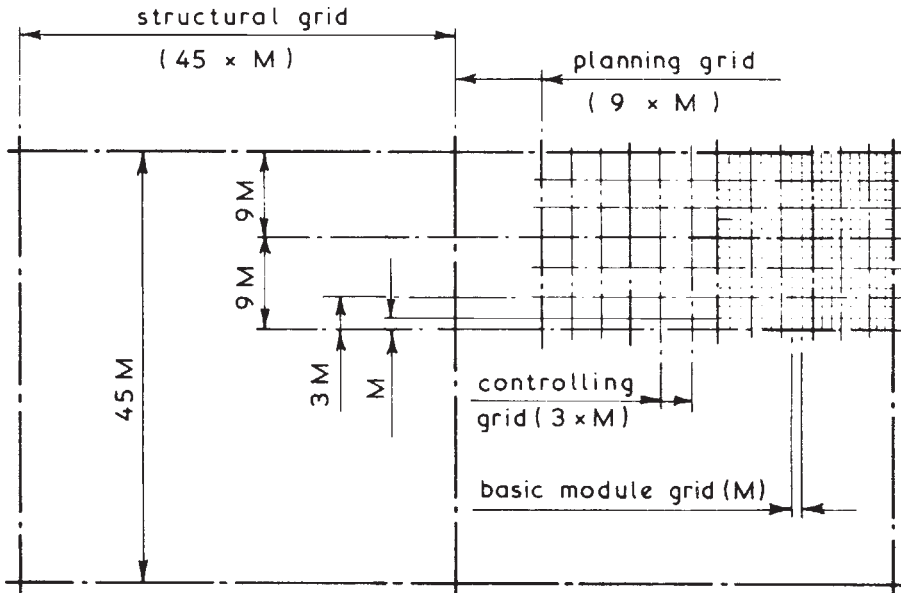

Structural Grid ~ used to locate structural components such as beams and columns.

Planning Grid ~ based on any convenient modular multiple for regulating space requirements such as rooms.

Controlling Grid ~ based on any convenient modular multiple for location of internal walls, partitions, etc.

Basic Module Grid ~ used for detail location of components and fittings.

All the above grids, being based on a basic module, are contained one within the other and are therefore interrelated. These grids can be used in both the horizontal and vertical planes, thus forming a three-dimensional grid system. If a first preference numerical value is given to  $M$  dimensional coordination is established - see next page.

Ref. BS 6750: Specification for modular coordination in building.

Dimensional Coordination ~ the practical aims of this concept are to:

1. Size components so as to avoid the wasteful process of cutting and fitting on site.
2. Obtain maximum economy in the production of components.
3. Reduce the need for the manufacture of special sizes.
4. Increase the effective choice of components by the promotion of interchangeability.

BS 6750 specifies the increments of size for coordinating dimensions of building components thus:

Preference	1st	2nd	3rd	4th	the 3rd and 4th preferences having a maximum of 300mm
Size (mm)	300	100	50	25	

Dimensional Grids - the modular grid network as shown on page 52 defines the space into which dimensionally coordinated components must fit. An important factor is that the component must always be undersized to allow for the joint which is sized by the obtainable degree of tolerance and site assembly:

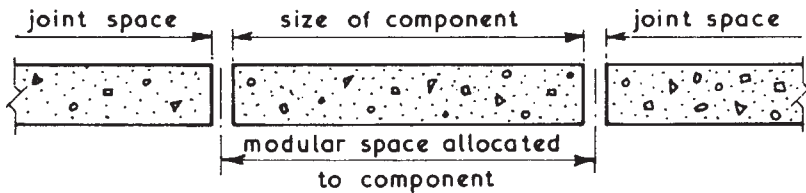

Controlling Lines, Zones and Controlling Dimensions - these terms can best be defined by example:

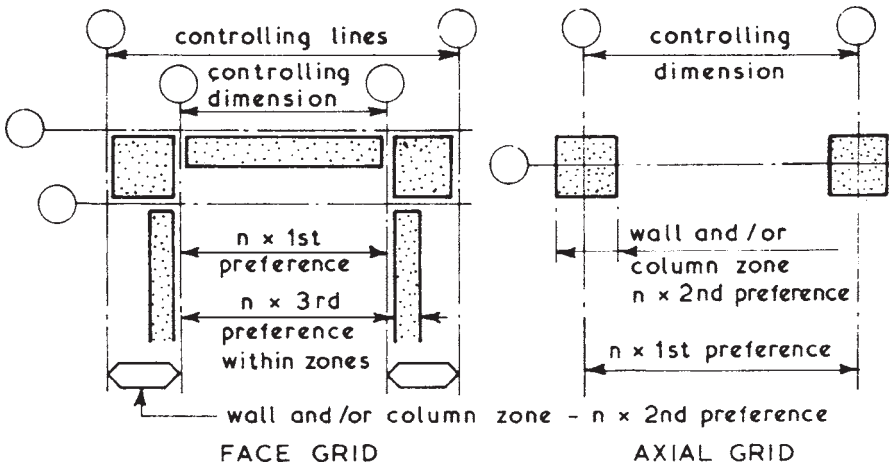

## Construction Regulations

Construction Regulations ~ these are Statutory Instruments made under the Factories Acts of 1937 and 1961. They are now largely superseded by the Health and Safety at Work, etc. Act 1974, but still have relevance to aspects of hazardous work on construction sites. The requirements contained within these documents must therefore be taken into account when planning construction operations and during the actual construction period. Reference should be made to the relevant document for specific requirements but the broad areas covered can be shown thus:

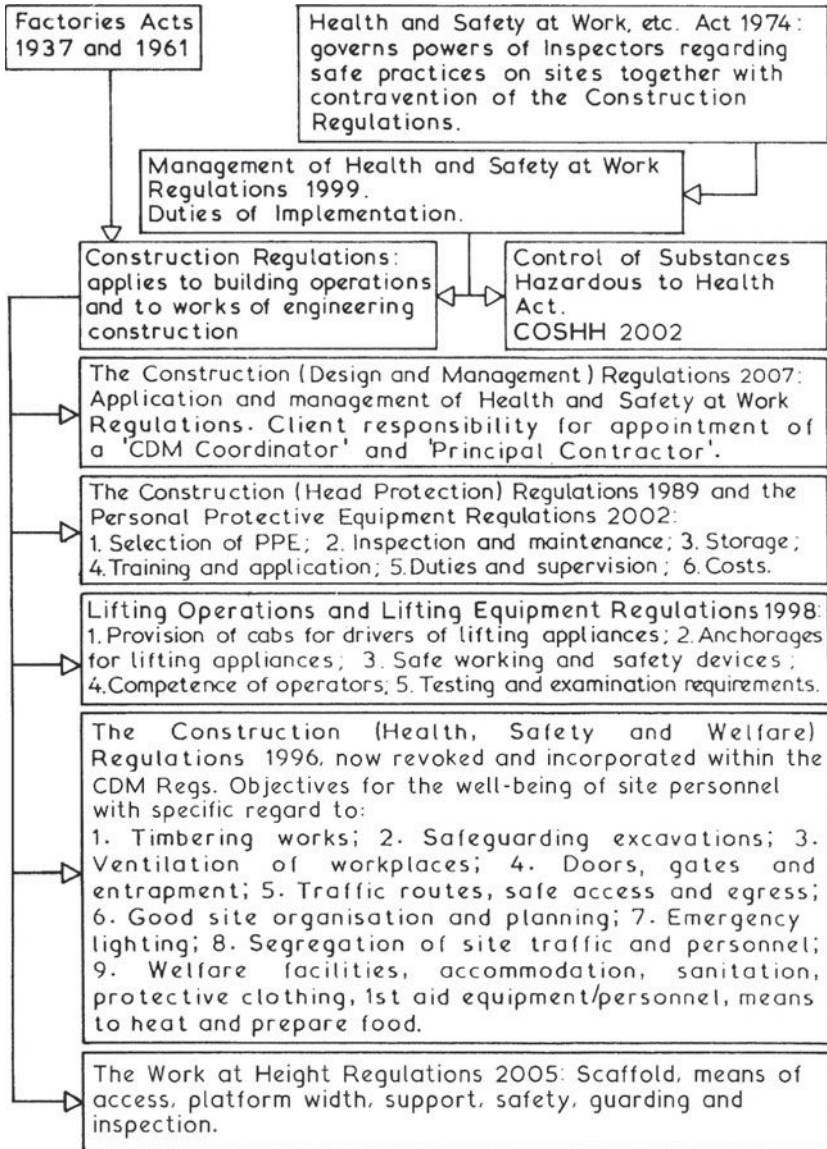

**Objective** – To create an all-party integrated and planned approach to health and safety throughout the duration of a construction project.

**Administering Body** – The Health and Safety Executive (HSE).

**Scope** – The CDM Regulations are intended to embrace all aspects of construction, with the exception of very minor works.

**Responsibilities** – The CDM Regulations apportion responsibility to everyone involved in a project to cooperate with others and for health and safety issues to all parties involved in the construction process, i.e. client, designer, CDM coordinator and principal contractor.

**Client** – Appoints a CDM coordinator and the principal contractor. Provides the CDM coordinator with information on health and safety matters and ensures that the principal contractor has prepared an acceptable construction phase plan for the conduct of work. Ensures adequate provision for welfare and that a health and safety file is available.

**Designer** – Establishes that the client is aware of their duties. Considers the design implications with regard to health and safety issues, including an assessment of any perceived risks. Coordinates the work of the CDM coordinator and other members of the design team.

**CDM Coordinator** – Ensures that:

- A pre-tender, construction phase plan is prepared.
- The HSE are informed of the work.
- Designers are liaising and conforming with their health and safety obligations.
- A health and safety file is prepared.
- Contractors are of adequate competence with regard to health and safety matters and advises the client and principal contractor accordingly.

**Principal Contractor** – Develops a construction phase plan, collates relevant information and maintains it as the work proceeds. Administers day-to-day health and safety issues. Cooperates with the CDM coordinator, designers and site operatives preparing risk assessments as required.

**Note:** Requirements defined under the withdrawn Construction (Health, Safety and Welfare) Regulations are incorporated into the CDM Regulations.

## Health and Safety — Signs and Symbols (1)

Health and Safety at Work, etc. Act 1974

The Health and Safety  
(Safety Signs and Signals)  
Regulations 1996

Management of Health and  
Safety at Work Regulations  
1999 (Management Regulations)

Under these regulations, employers are required to provide and maintain health and safety signs conforming to European Directive 92/58 EEC:

PROHIBITION



Red

HAZARD/WARNING



Yellow

MANDATORY

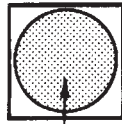

Blue

SAFE CONDITION

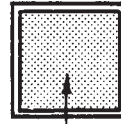

Green

In addition, employers' obligations include the need to provide:

Risk Assessment - provide and maintain safety signs where there is a risk to health and safety, e.g. obstacles. Train staff to comprehend safety signs.

Pictorial Symbols - pictograms alone are acceptable but supplementary text, e.g. FIRE EXIT, is recommended.

Fire/Emergency Escape Signs - A green square or rectangular symbol.

Positioning of signs - primarily for location of fire exits, fire equipment, alarms, assembly points, etc. Not to be located where they could be obscured.

Marking of Hazardous Areas - to identify designated areas for storing dangerous substances: Dangerous Substances (Notification and Marking of Sites) Regulations 1990. Yellow triangular symbol.

Pipeline Identification - pipes conveying dangerous substances to be labelled with a pictogram on a coloured background conforming to BS 1710: Specification for identity of pipelines and services and BS 4800: Schedule of paint colours for building purposes. Non-dangerous substances should also be labelled for easy identification.

Typical Examples on Building Sites ~

PROHIBITION (Red)



Authorised personnel only



Children must not play on this site



Smoking prohibited



Access not permitted

HAZARD/WARNING (Yellow)



Dangerous substance



Flammable liquid



Danger of electric shock



Compressed gas

MANDATORY (Blue)



Safety helmets must be worn



Protective footwear must be worn



Use ear protectors

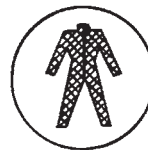

Protective clothing must be worn

SAFE CONDITIONS (Green)



Emergency escapes



FIRE  
EXIT



Treatment area



A

Safe area

Ref. BS ISO 3864-1: Graphical symbols. Safety colours and safety signs. Design principles for safety signs and safety markings.

## Building Control — History and Development (1)

Control over the way that buildings are constructed originated from attempts to regulate development density in response to demand for more living space as city populations increased. Although there is little surviving documentation to support effective building controls from the time, archived records of London dating from the 12th century do provide some indication that communal issues of convenience and privacy were monitored by the city administration. These included provisions for sanitation, dividing walls and control over encroachment.

Throughout the latter part of the Middle Ages (about 1200 to 1500), regulation in London was haphazard and spontaneous, usually effected on the basis of complaints about building nuisance, whereby the city mayor and aldermen presided over a court hearing. The outcome was determined on the complainant's evidence and expert reports from appointed surveyors. An exception was an overall ban on thatched roofs in London following a serious spread of fire in 1212.

Other densely populated cities established their own means for controlling building work. Fire hazard was the principle criteria and restrictions were applied to limit the ever rising timber framed houses where storeys were built upon existing storeys and extensive jetties of dubious construction overhung the streets below.

The bubonic plague (1665 to 1666) followed by the Great Fire of London (1666) provided an unplanned opportunity to significantly reconsider procedures for new building work. Redevelopment with regard to better living standards and the health and safety of building occupants resulted from the introduction of the London Building Act in 1667. This Act enabled city surveyors to enforce regulations which included:

- Non-combustible material for the main structure, i.e. brick or stone.
- Wall thickness of a minimum specification.
- Limited storey height.
- No projections or jetties over the streets below.
- Minimum street widths to function as fire breaks.

London Building Acts of 1707, 1709, 1764 and 1772 widened control of building development to suburban areas beyond the city boundary. Further provisions prohibited the use of timber for application to decorative cornices and established minimum heights for parapet walls.

London Building Act 1774 ~ known as the *Black Act*, consolidated previous Building Acts as well as determining acceptable construction methods for the whole of London's suburban areas. It remained effective well into the 19th. century, until the introduction of the Metropolitan Building Act of 1844. The main objective of the 1774 Act was to fire proof the exterior of buildings by prohibiting superfluous use of timber ornamentation and other wooden features. An exception was made for timber doors and window frames. These were permitted if recessed at least 4'' (100mm) behind the wall face. The London Building Acts were emulated throughout other provincial towns and cities in the UK. This was mainly in response to outbreaks of fire spreading between cheaply constructed and uncontrolled, overdeveloped timber housing.

Metropolitan Building Act 1844 ~ this extended the area around London covered by building controls. It empowered the appointment of district surveyors to visit building sites and inspect work in progress.

Public Health Act 1848 ~ created municipal *Boards of Health* through local authorities in England and Wales. Mandatory provisions included minimum standards for structural stability, sanitation, light and ventilation and for the prevention of dampness in buildings.

Local Government Act 1858 ~ extended the powers of local authorities to supervise and control building construction through bye-laws. The national government published guidelines known as the *Form of Bye-laws* which were adopted by most local authorities. These permitted LAs to demand deposit of plans and specifications for new building work and substantial alterations to existing buildings.

Public Health Act 1875 ~ consolidated existing building control legislation for England and Wales. Ireland and Scotland passed similar legislation in 1878 and 1897 respectively. The most notable provision was a requirement for installation of damp proof courses in walls.

Thereafter, LAs administered their own interpretation of building control through their bye-laws. This presented problems, as standards varied throughout the UK. It was not until the mid-20th century that some form of unification was introduced.



## Building Control — History and Development (3)

Public Health Act 1936 ~ this covered all buildings intended for human occupation and was primarily concerned with provisions for drainage and sanitation. Empowered LAs with responsibility for adoption and maintenance of public sewers and drains. Introduced new guidelines in the form of model bye-laws which LAs could enforce.

Model Bye-laws 1952 ~ produced as a means for unifying the standards of building throughout England and Wales. One model for all areas was designed to avoid urban and rural variations in performance standards. Introduced *deemed to satisfy* provisions with reference to established quality benchmarks such as British Standards.

Building (Scotland) Act 1959 ~ enabled Scotland to adopt national building standards which formed the first Building Regulations in the UK. These came into force in 1964.

Public Health Act 1961 ~ statutory unification of building standards that became the forerunner to the first Building Regulations. Proposed replacement of local bye-laws with nationally acceptable regulations. Central government responsibility for establishing minimum building standards administered through the LAs of England and Wales.

Building Regulations 1966 on ~ the first unified regulations made as a statutory instrument. Excluded inner London, Scotland and Ireland. In 1972 amendments and updates were issued as a second edition. In the same year the Building Regulations (Northern Ireland) Order was established as the first regulations for that region. These were modeled closely on the second edition for England and Wales. In 1976, further amendments were consolidated into the third edition, which incorporated Approved Documents as *deemed to satisfy* practice guidelines that could be used to satisfy the regulations.

Building Act 1984 ~ consolidated various other building legislation and redefined the Building Regulations. From 1985 the regulations were based on performance and presented in a simpler format. Previous editions were considered too prescriptive, confusing and inflexible. That year the Building (Inner London) Regulations incorporated most of the 1985 regulations for England and Wales with some limited exceptions. Bye-laws made under the previous London Acts no longer applied. In 2012 Wales determined its own building regulations.

The Building Regulations ~ this is a Statutory Instrument which sets out the minimum performance standards for the design and construction of buildings and where applicable to the extension and alteration of buildings. The regulations are supported by other documents which generally give guidance on how to achieve the required performance standards. The relationship of these and other documents is set out below:

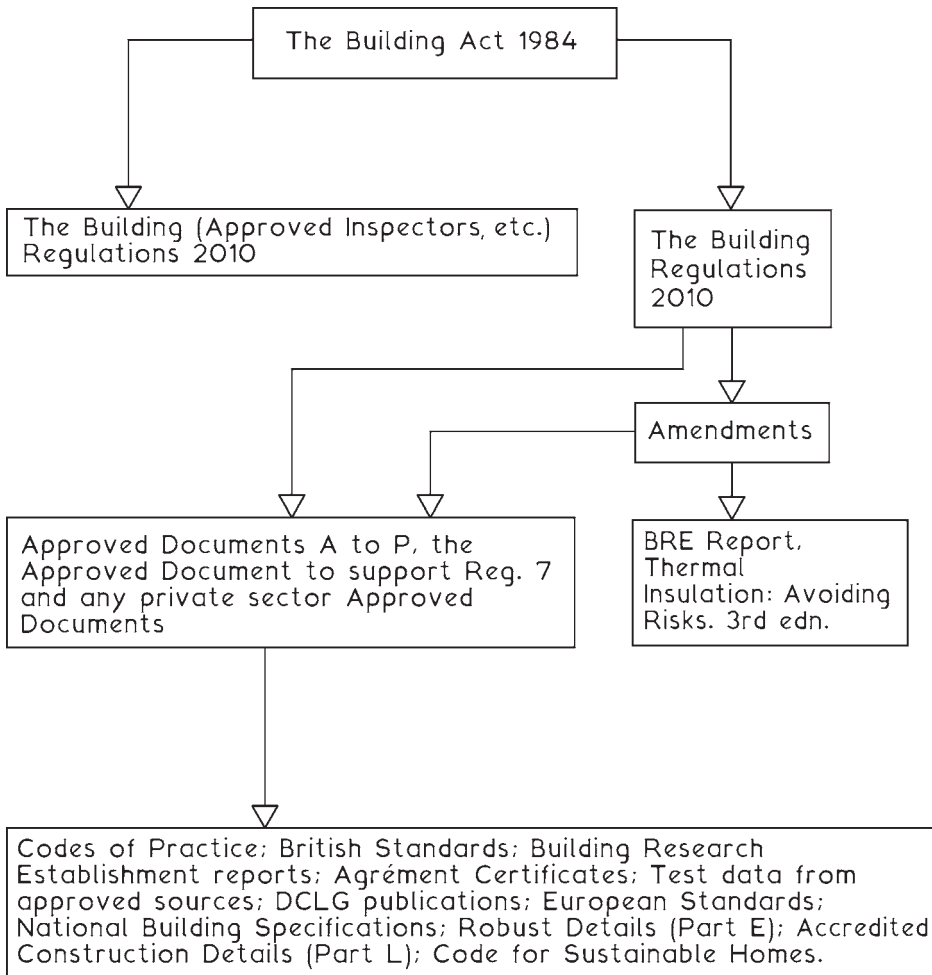

Building Regulations apply throughout the UK. Specific requirements for England, Wales, Scotland and Northern Ireland are administered by their regional governments.

## Building Regulations — Approved Documents

Approved Documents ~ these publications support the Building Regulations. They are prepared by the Department for Communities and Local Government, approved by the Secretary of State and issued by The Stationery Office. The Approved Documents (ADs) have been compiled to give practical guidance to comply with the performance standards set out in the various Regulations. They are not mandatory but show compliance with the requirements of the Building Regulations. If other solutions are used to satisfy the requirements of the Regulations, proving compliance rests with the applicant or designer.

Approved Document A — STRUCTURE

Approved Document B — FIRE SAFETY  
Volume 1 – Dwelling houses  
Volume 2 – Buildings other than dwelling houses

Approved Document C — SITE PREPARATION AND RESISTANCE  
TO CONTAMINANTS AND MOISTURE

Approved Document D — TOXIC SUBSTANCES

Approved Document E — RESISTANCE TO THE PASSAGE OF SOUND

Approved Document F — VENTILATION

Approved Document G — SANITATION, HOT WATER SAFETY  
AND WATER EFFICIENCY

Approved Document H — DRAINAGE AND WASTE DISPOSAL

Approved Document J — COMBUSTION APPLIANCES AND FUEL  
STORAGE SYSTEMS

Approved Document K — PROTECTION FROM FALLING, COLLISION  
AND IMPACT

Approved Document L — CONSERVATION OF FUEL AND POWER  
L1A — New dwellings  
L1B — Existing dwellings  
L2A — New buildings other than dwellings  
L2B — Existing buildings other than dwellings

Approved Document M — ACCESS TO AND USE OF BUILDINGS

Approved Document P — ELECTRICAL SAFETY-DWELLINGS

Approved Document to support Regulation 7  
MATERIALS AND WORKMANSHIP

Example in the Use of Approved Documents ~

Problem: the sizing of suspended upper floor joists to be spaced at 400mm centres with a clear span of 3.600m for use in a two-storey domestic dwelling.

Building Regulation A1: states that the building shall be constructed so that the combined dead, imposed and wind loads are sustained and transmitted by it to the ground -

- (a) safely, and
- (b) without causing such deflection or deformation of any part of the building, or such movement of the ground, as will impair the stability of any part of another building.

Approved Document A: guidance on sizing floor joists can be found in 'Span Tables for Solid Timber Members in Dwellings', published by the Timber Research And Development Association (TRADA), and BS EN 1995-1-1: Design of timber structures. General. Common rules and rules for building.

Solution :-

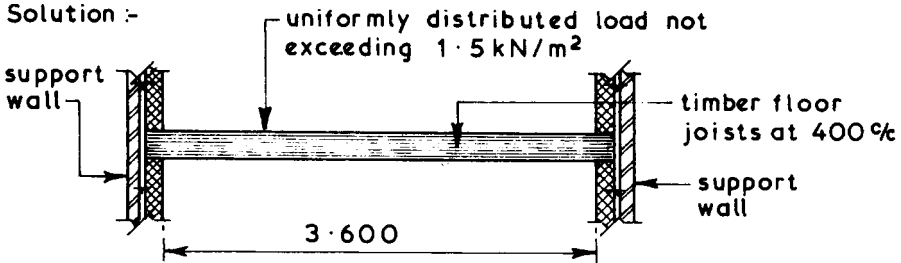

Dead load (kN/m<sup>2</sup>) supported by joist excluding mass of joist:

Floor finish — carpet	— 0.03	} weights of materials from BS648
Flooring — 20mm thick particle board	— 0.15	
Ceiling — 9.5mm thick plasterboard	0.08	
Ceiling finish — 3mm thick plaster	— 0.04	
total dead load —		<u>0.30kN/m<sup>2</sup></u>

Dead loading is therefore in the 0.25 to 0.50kN/m<sup>2</sup> band

From table on page 776 suitable joist sizes are:- 38 × 200, 50 × 175, 63 × 175 and 75 × 150.

Final choice of section to be used will depend upon cost; availability; practical considerations and/or personal preference.

## Building Regulations – Control

Building Control ~ unless the applicant has opted for control by a private approved inspector under The Building (Approved Inspectors, etc.) Regulations 2010 the control of building works in the context of the Building Regulations is vested in the Local Authority. There are two systems of control: namely the Building Notice and the Deposit of Plans. The sequence of systems is shown below:

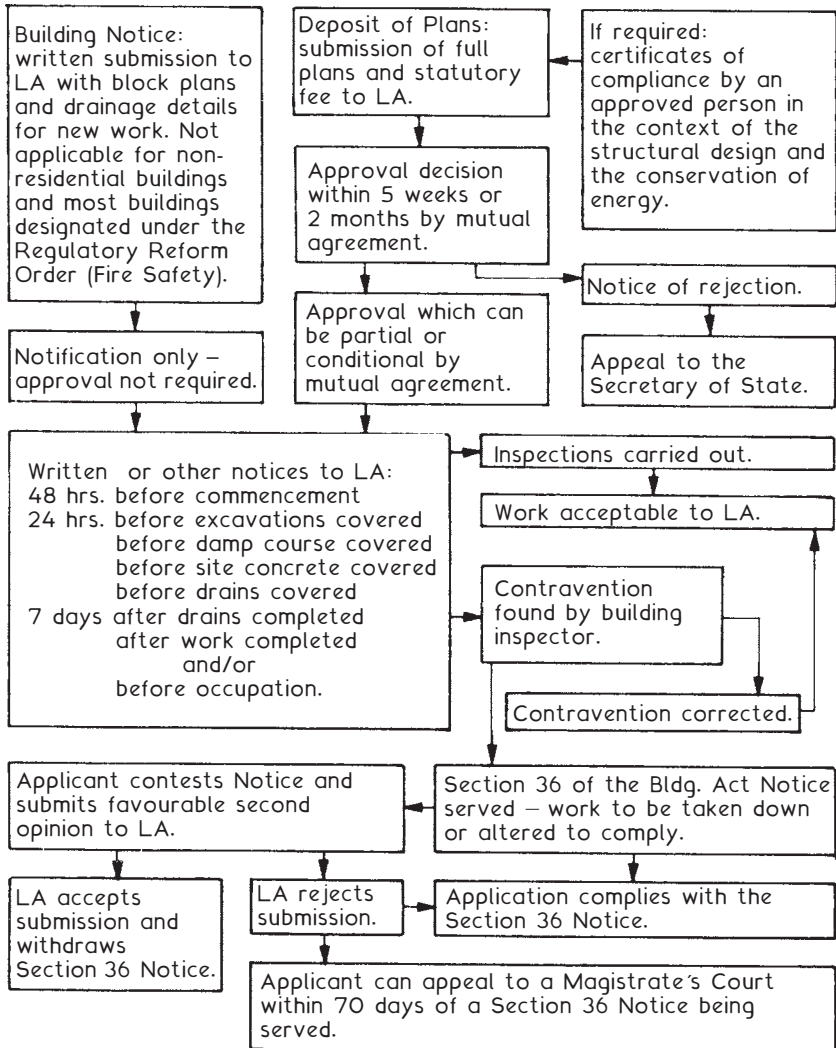

NB. In some stages of the above sequence statutory fees are payable as set out in The Building (Local Authority Charges) Regulations 2010.

Building Regulations Approval ~ required if “Building Work” as defined in Regulation 3 of the Building Regulations is proposed. This includes:

- Construction or extension of a building.
- Alterations to an existing building that would bring into effect any of the complying regulations.
- Installing replacement windows where the installer is not known to the local Building Control Authority as being a ‘competent’ registered installer, e.g. FENSA (**FEN**estration **Self-Assessment**) scheme.
- Alteration or installation of building services and fittings that bring into effect any of the complying regulations.
- Installation of cavity wall insulation.
- Underpinning of a building’s foundations.
- Change of purpose or use of a building.

‘Competent’ persons are appropriately qualified and experienced to the satisfaction of a relevant scheme organiser. For example, Capita Group’s ‘Gas Safe Register’ of engineers for gas installation and maintenance services. They can ‘self-certify’ that their work complies with Building Regulations, thereby removing the need for further inspection (see next page).

Local Authority Building Control ~ the established procedure as set out diagrammatically on the preceding page with an application form of the type shown on page 70 and accompanying documents as indicated on page 68.

Private Sector Building Control ~ an alternative, where suitably qualified and experienced inspectors approved by the Local Authority undertake the application approval and site inspections. An ‘Initial Notice’ from the client and their appointed inspector is lodged with the Local Authority.

Whichever building control procedure is adopted, the methodology is the same, i.e. Deposit of Plans or Building Notice (see page 68).

Refs.: The Building (Approved Inspectors, etc.) Regulations.  
The Association of Consultant Approved Inspectors.

## Building Regulations — Installer Notification

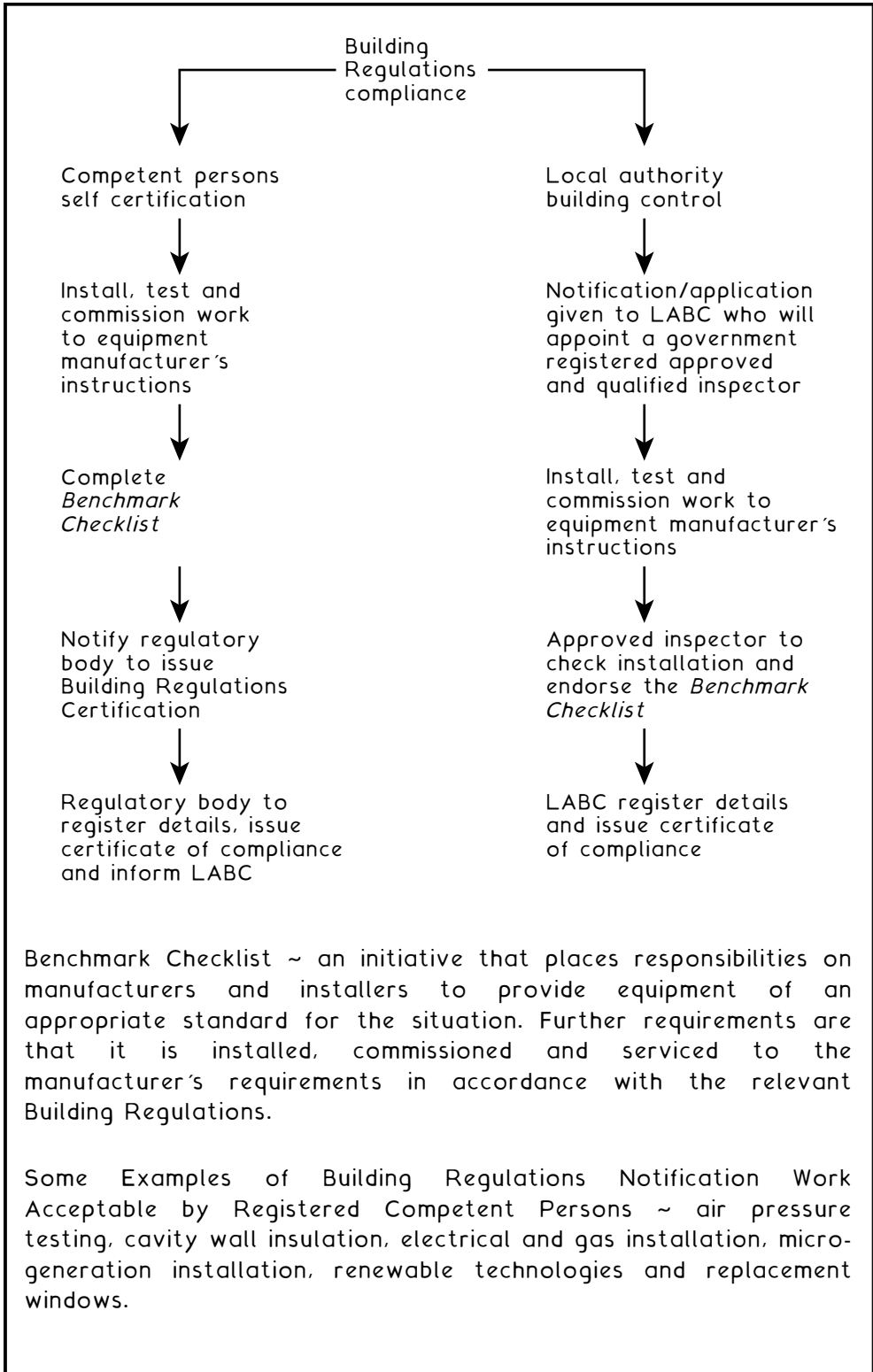

Benchmark Checklist ~ an initiative that places responsibilities on manufacturers and installers to provide equipment of an appropriate standard for the situation. Further requirements are that it is installed, commissioned and serviced to the manufacturer's requirements in accordance with the relevant Building Regulations.

Some Examples of Building Regulations Notification Work Acceptable by Registered Competent Persons ~ air pressure testing, cavity wall insulation, electrical and gas installation, micro-generation installation, renewable technologies and replacement windows.

Local Authority Building Control ~ as described in the previous two pages. A public service administered by borough and unitary councils through their building control departments.

Approved Inspectors ~ a private sector building control alternative as outlined on the preceding page. Approved inspectors may be suitably qualified individuals or corporate bodies employing suitably qualified people, e.g. National House Building Council (NHBC Ltd) and MD Insurance Services Ltd.

Borough councils can contract out the building control process to approved inspectors. Validation and site examinations follow the established format shown on page 64, with approved inspectors substituting for LA.

Both NHBC and MD Insurance publish their own construction rules and standards that supplement the Building Regulations. These form the basis for their own independent quality control procedures whereby their Inspectors will undertake stage and periodic examinations of work in progress to ensure that these standards are adhered to. The objective is to provide new home buyers with a quality assured product warranted against structural defects (10–15 years), provided the house builder has satisfied certain standards for registration. Therefore, the buyer should be provided with a completion certificate indicating Building Regulations approval and a warranty against defects.

Robust Details ~ Building Regulations A.D. E - Resistance to the passage of sound; requires that the separating walls, floors and stairs in new dwellings are sufficiently resistant to airborne and impact sound transmission. Sound measurement tests defined in the associated BSs specified in the Approved Document must be undertaken by an approved inspector/building control official before completion.

An alternative or a means for exemption of pre-completion testing is for the builder to notify the building inspector that sound insulation construction details are registered and specified to those approved by Robust Details Ltd. This is a not-for-profit company established by the house building industry to produce guidance manuals containing details of acceptable sound resistant construction practice.



## Building Regulations – Validation

### Deposit of Plans or Full Plans Application ~

- Application form describing the proposed work.
- Location plan, scale not less than 1:2500.
- Block plan, scale not less than 1:1250 showing north point, lines of drains (existing and proposed) and size and species of trees within 30m.
- Plans, sections and elevations, scale not less than 1:50 (1:100 may be acceptable for elevations).
- Materials specification.
- Structural calculations where appropriate, e.g. load-bearing beams.
- Fee depending on a valuation of work.

The appointed inspector examines the application and, subject to any necessary amendments, an approval is issued. This procedure ensures that work on site is conducted in accordance with the approved plans. Also, where the work is being financed by a loan, the lender will often insist the work is only to a Full Plans approval.

### Building Notice ~

- A simplified application form.
- Block plan as described above.
- Construction details, materials specification and structural calculations if considered necessary by the inspector.
- Fee depending on a valuation of work.

This procedure is only really appropriate for minor work, for example, extensions to existing small buildings such as houses. Building control/inspection occurs as each element of the work proceeds. Any Building Regulation contravention will have to be removed or altered to attain an acceptable standard.

### Regularisation ~

- Application form.
- Structural calculations if relevant.
- A proportionally higher fee.

Applies to unauthorised work undertaken since November 1985. In effect a retrospective application that will involve a detailed inspection of the work. Rectification may be necessary before approval is granted.

**Small detached buildings:-**

1. floor area < 15m<sup>2</sup> not containing sleeping accommodation, or
2. floor area < 30m<sup>2</sup> not containing sleeping accommodation, and either:
  - constructed substantially from non-combustible materials, or
  - located in excess of 1m from the boundary

The guidance shown indicates the categories of buildings that do not normally require submission of a Building Notice or Deposit of Plans for approval by the Building Control Section of the Local Authority. However, they may still require planning permission – see page 45

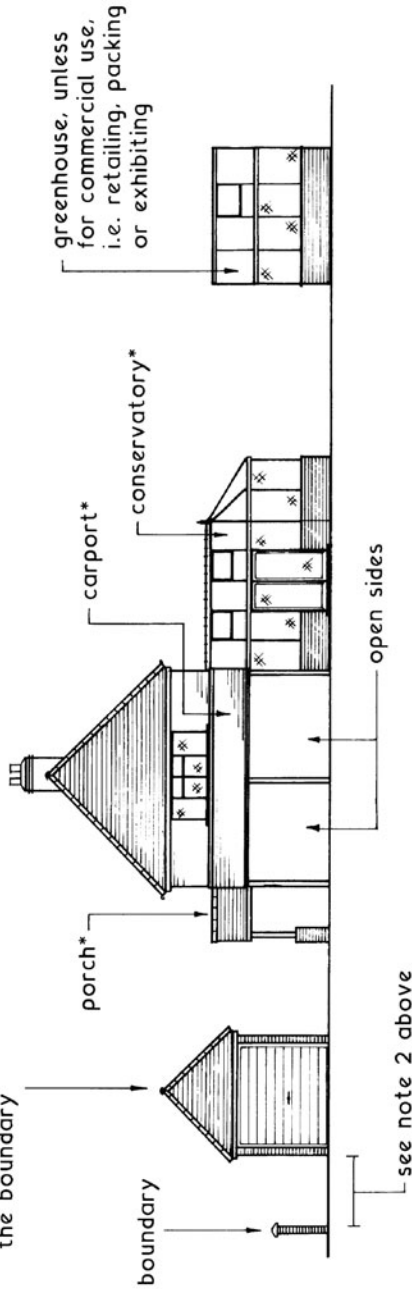

\* Single storey ground level additions which are not open to the house and are < 30m<sup>2</sup> floor area, to include carport, covered yard, conservatory and porch.

- Notes:
1. a carport must be open on at least two sides.
  2. conservatories must have fully glazed laminated or toughened glass, or translucent plastic roofs.
  3. glazed doors and windows in a porch or conservatory as defined in Buildings Regulations Approved Document K – see page 45B
  4. single storey additions should not impede escape from an upper floor window specified for emergency egress. Building Regulations, A.D.: B1 Section 2

# BUILDING REGULATIONS APPLICATION

Use this form to give notice of intention to erect, extend, or alter a building, install fittings or make a material change of use of the building.

Unless specified differently overleaf, Please return:-

- 2 copies of the Form
- 4 copies of the Plans
- the correct fee

APPLICATION No

DATE RECEIVED

**1. NAME AND ADDRESS OF APPLICANT**

Applicant will be invoiced on commencement of work.

\_\_\_\_\_

\_\_\_\_\_

\_\_\_\_\_

Post Code \_\_\_\_\_

Tel. No. \_\_\_\_\_

**2. NAME AND ADDRESS OF AGENT (If Used)**

\_\_\_\_\_

\_\_\_\_\_

\_\_\_\_\_

Post Code \_\_\_\_\_

Tel. No. \_\_\_\_\_

**3. ADDRESS OR LOCATION OF PROPOSED WORK**

\_\_\_\_\_

\_\_\_\_\_

\_\_\_\_\_

**4. DESCRIPTION OF PROPOSED WORKS**

\_\_\_\_\_

\_\_\_\_\_

\_\_\_\_\_

**5. IF NEW BUILDING OR EXTENSION PLEASE STATE PROPOSED USE**

\_\_\_\_\_

\_\_\_\_\_

**6. IF EXISTING BUILDING PLEASE STATE PRESENT USE**

\_\_\_\_\_

\_\_\_\_\_

**7. DRAINAGE**

Please state means of:-

Water Supply \_\_\_\_\_

Foul Water Disposal \_\_\_\_\_

Storm Water Disposal \_\_\_\_\_

**8. CONDITIONS**

Do you consent to the Plans being passed subject to conditions where appropriate? Yes  No

Do you agree to an extension of time if this is required by the Council? Yes  No

**9. COMPLETION CERTIFICATE**

Do you wish the Council to issue a Completion Certificate upon satisfactory completion of the work?

Yes  No

**10. REGULATORY REFORM ORDER (Fire Safety) 2005**

Is the building intended for any other purpose than occupation as a domestic living unit by one family group?

Yes  No

**11. FEE**

Please state estimated cost of the work (at current market value) £..... Amount of Fee submitted £.....

Has Planning Permission been sought? Yes  No  If Yes, please give Application No \_\_\_\_\_

**12. PLEASE SIGN AND DATE THIS FORM BEFORE SUBMITTING**

I/We hereby give notice of intention to carry out the work set out above and deposit the attached drawings and documents in accordance with the requirements of Regulations 11 (1) (b). Also enclosed is the appropriate Plan Fee and I understand that a further Fee will be payable when the first inspection of work on site is made by the Local Authority.

Signed \_\_\_\_\_ Date \_\_\_\_\_ On behalf of (if agent) \_\_\_\_\_

Purpose ~ to provide a checklist that assists designers and builders to attain performance standards that will satisfy the energy efficiency requirements of Part L to the Building Regulations. Also, to provide a measure against which the building control inspectorate can ensure conformity.

Documentation ~ a UK Department for Communities and Local Government (DCLG) publication. This contains a series of construction details that are applied to five different building techniques. The fully detailed illustrations are for relatively light construction appropriate to dwellings. The details and supplementary support notes concentrate on continuity of thermal insulation with a regard for thermal (cold) bridging and on quality of construction to maintain airtightness.

Publication sections and details ~

Section 1: Introduction relating mainly to continuity of insulation and airtightness.

Section 2: Detailed drawings and checklists for constructing the external envelope.

The five types of construction are:

- Externally insulated masonry solid walls.
- Part and fully filled cavity insulated masonry walls.
- Internally insulated masonry walls.
- Timber framed walls.
- Lightweight steel framed walls.

Note: All five construction practice details include the critical areas of junctions and interfaces between wall and roof, ground and intermediate floors. Treatment at door and window openings is also included with specific applications where appropriate.

Refs.:

The Building Regulations 2010 and associated Approved Document L: Conservation of Fuel and Power.

Accredited Construction Details, Communities and Local Government publications.

## Code for Sustainable Homes

Published ~ 2006 by the Department for Communities and Local Government (DCLG) in response to the damaging effects of climate change. The code promotes awareness and need for new energy conservation initiatives in the design of new dwellings.

Objective ~ to significantly reduce the 27% of UK CO<sub>2</sub> emissions that are produced by 25 million homes. This is to be a gradual process, with the target of reducing CO<sub>2</sub> and other greenhouse gas emissions from all UK sources by 80% by 2050 relative to 1990 levels. Interim objectives are 28% by 2017, 34% by 2022 and 50% by 2027.

Sustainability ~ measured in terms of a quality standard designed to provide new homes with a factor of environmental performance. This measure is applied primarily to categories of thermal energy, use of water, material resources, surface water run-off and management of waste.

Measurement ~ a 'green' star rating that indicates environmental performance ranging from one to six stars. Shown below is the star rating criteria applied specifically to use of thermal energy. A home with a six star rating is also regarded as a Zero Carbon Home.

Proposed Progression ~

Percentage Improvement compared with A.D. L 2006	Year	Code level star rating
10	-	1
18	-	2
25	2010	3
44	2013	4
100	2016	5 and 6

Zero Carbon Home ~ zero net emissions of CO<sub>2</sub> from all energy use in the home. This incorporates insulation of the building fabric, heating equipment, hot water systems, cooling, washing appliances, lighting and other electrical/electronic facilities. Net zero emissions can be measured by comparing the carbon emissions produced in consuming on- or off-site fossil fuel energy use in the home, with the amount of on-site renewable energy produced. Means for producing low or zero carbon energy include micro combined heat and power units, photovoltaic (solar) panels, wind generators and ground energy heat pumps (see Building Services Handbook).

British Standards ~ these are publications issued by the British Standards Institution which give recommended minimum standards for materials, components, design and construction practices. These recommendations are not legally enforceable but some of the Building Regulations refer directly to specific British Standards and accept them as deemed to satisfy provisions. All materials and components complying with a particular British Standard are marked with the British Standards kitemark thus:  together with the appropriate BS number.

This symbol assures the user that the product so marked has been produced and tested in accordance with the recommendations set out in that specific standard. Full details of BS products and services can be obtained from Customer Services, BSI, 389 Chiswick High Road, London W4 4AL. Standards applicable to building may be purchased individually or in modules for General Construction, Materials, Health and Safety, Project and Design, Interior and Utility and Eurocodes. British Standards are constantly under review and are amended, revised and rewritten as necessary; therefore a check should always be made to ensure that any standard being used is the current issue. There are over 1500 British Standards which are directly related to the construction industry and these are prepared in five formats:

1. British Standards - these give recommendations for the minimum standard of quality and testing for materials and components. Each standard number is prefixed BS.
2. Codes of Practice - these give recommendations for good practice relative to design, manufacture, construction, installation and maintenance with the main objectives of safety, quality, economy and fitness for the intended purpose. Each code of practice number is prefixed CP or BS.
3. Draft for Development - these are issued instead of a British Standard or Code of Practice when there is insufficient data or information to make firm or positive recommendations. Each draft number is prefixed DD. Sometimes given a BS number and suffixed DC, i.e. Draft for public Comment.
4. Published Document - these are publications which cannot be placed into any one of the above categories. Each published document is numbered and prefixed PD.
5. Publicly Available Specification - client sponsored standards produced to BSI guidelines. Reviewed after two years to determine whether they should become established as a BS. Prefixed PAS.

## European Standards

European Standards – since joining the European Union (EU), trade and tariff barriers have been lifted. This has opened up the market for manufacturers of construction-related products, from all EU and European Economic Area (EEA) member states. Before 2004, the EU was composed of 15 countries: Austria, Belgium, Denmark, Finland, France, Germany, Greece, Ireland, Italy, Luxemburg, Netherlands, Portugal, Spain, Sweden and the United Kingdom. It now includes Bulgaria, Cyprus, the Czech Republic, Estonia, Hungary, Latvia, Lithuania, Malta, Poland, Romania, Slovakia, Slovenia, Iceland, Liechtenstein and Norway. Nevertheless, the wider market is not so easily satisfied, as regional variations exist. This can create difficulties where product dimensions and performance standards differ. For example, thermal insulation standards for masonry walls in Mediterranean regions need not be the same as those in the UK. Also, preferred dimensions differ across Europe in items such as bricks, timber, tiles and pipes.

European Standards are prepared under the auspices of Comité Européen de Normalisation (CEN), of which the BSI is a member. European Standards that the BSI have not recognised or adopted are prefixed EN. These are EuroNorms and will need revision for national acceptance.

For the time being, British Standards will continue and, where similarity with other countries' standards and ENs can be identified, they will run side by side until harmonisation is complete and approved by CEN.

e.g. BS EN 295 complements the previous national standard:  
BS 65 – Vitrefied clay pipes . . . for drains and sewers.

European Pre-standards are similar to BS Drafts for Development. These are known as ENVs.

Some products which satisfy the European requirements for safety, durability and energy efficiency carry the CE mark. This is not to be assumed as a mark of performance and is not intended to show equivalence to the BS kitemark. However, the BSI is recognised as a Notified Body by the EU and as such is authorised to provide testing and certification in support of the CE mark.

International Standards – these are prepared by the International Organisation for Standardisation and are prefixed ISO. Many are compatible with, complement and have superseded BSs, e.g. ISO 9001 Quality Management Systems and BS 5750: Quality Systems.

## Construction Products Regulation (CPR)

For manufacturers' products to be compatible and uniformly acceptable in the European market, there exists a process for harmonising technical specifications. These specifications are known as harmonised European product standards (hENs), produced and administered by the Comité Européen de Normalisation (CEN). European Technical Approvals (ETAs) are also acceptable where issued by the European Organisation for Technical Approvals (EOTA).

CPR harmonises the following compliance requirements:

- Energy economy and heat retention.
- Hygiene, health and environment.
- Mechanical resistance and stability.
- Protection against noise.
- Safety and accessibility in use.
- Safety in case of fire.
- Sustainable use of natural resources.

Member states of the European Economic Area (EEA) are legally required to ensure their construction products satisfy the above basic criteria.

UK attestation accredited bodies include: BBA, BRE and BSI.

CE mark - a marking or labelling for conforming products. A 'passport' permitting a product to be legally marketed in any EEA. It is not a quality mark, e.g. BS kitemark, but where appropriate this may appear with the CE marking.

Product Name	<b>CAVITY WALL BATT</b>		
	Thickness (mm)	Length (mm)	
Thickness	<b>100</b>	<b>1200</b>	Length
		Width (mm)	
		<b>455</b>	Width
	Fire Class	Pieces/Pack: <b>6</b>	Pieces per Pack
Reaction to Fire Classification	<b>A1</b>	Area (m <sup>2</sup> ): <b>3.28</b>	m <sup>2</sup>
CE Mark	<b>CE</b>		
BSI Number	<b>0086</b>		
Year CE Mark Affixed	<b>02</b>		
Certificate of Conformity No.	<b>0086-CPD-461281</b>		
	$\lambda = 0.036$ ; $R = 2.75$		Thermal Conductivity & Thermal Resistance Values
European Product Standard	<b>MW-EN13162-T2-WS-WL(P)</b>		Specific Product Test Results
<b>ROCKWOOL</b> Rockwool Limited    Pencoed    Bridgend    CF35 6NY Tel. 01656 862621    Fax. 01656 862302    www.rockwool.co.uk			

CE marking - reproduced with kind permission of Rockwool Ltd.



## Product and Practice Accreditation (1)

Building Research Establishment ~ The BRE was founded as a UK Government agency in 1921. It was known initially as the Building Research Department and thereafter until the early 1970s as the Building Research Station.

In addition to UK Government funding, some financial support is now provided by the European Union. Additional funding is derived from a variety of sources, including commercial services for private industry and from publications. The latter includes the BRE's well-known regular issue of research information products, i.e. Digests, Information Papers, Good Building Guides and Good Repair Guides.

UK Government support is principally through the Department for Business Enterprise and Regulatory Reform (BERR) and the Department for Communities and Local Government (DCLG). The DCLG works with the BRE in formulating specific aspects of the Approved Documents to the Building Regulations. Commissioned research is funded by the BRE Trust.

The BRE incorporates and works with other specialised research and material testing organisations, e.g. see LPCB, below. It is accredited under the United Kingdom Accreditation Service (UKAS) as a testing laboratory authorised to issue approvals and certifications such as CE product marking (see pages 75 and 76). Certification of products, materials and applications is effected through BRE Certification Ltd.

Loss Prevention Certification Board (LPCB) ~ The origins of this organisation date back to the latter part of the 19th century, when it was established by a group of building insurers as the Fire Offices' Committee (FOC).

Through a subdivision known as the Loss Prevention Council (LPC), the FOC produced a number of technical papers and specifications relating to standards of building construction and fire control installations. These became the industry standards that were, and continue to be, frequently used by building insurers as supplementary to local bye-laws and latterly the Building Regulation Approved Documents.

In the late 1980s the LPC was renamed the LPCB as a result of reorganisation within the insurance profession. At this time the former LPC guidance documents became established in the current format of Loss Prevention Standards.

In 2000 the LCPB became part of the BRE and now publishes its Standards under BRE Certification Ltd.

British Board of Agrément (BBA) ~ an approvals authority established in 1966, known then as the Agrément Board. It was based on the French Government's system of product approval. In 1982 it was renamed. Accredited by UKAS and a UK representative in EOTA.

The BBA's UK premises are at the BRE in Garston, near Watford, a convenient location for access to the BRE's research and testing facilities. It is an independent organisation with the purpose of impartially assessing materials, systems, practices, new market products and existing products being used in a new or innovative way. The objective is to evaluate these where an existing British Standard, Eurostandard or similar quality benchmark does not exist. Agrément certification is a quality assurance standard for products and innovations not covered by a CE mark and/or a BS kitemark. Once established, an agrément certificate may be used to attain CE marking or for development into a new BS.

Agrément certificates are only issued after rigorous testing and critical analysis criteria are satisfied, relative to intended application and fitness for purpose. Where new materials, products, components, installation processes and installations are proposed, an agrément certificate may be regarded as sufficiently authoritative for proof of Building Regulations compliance.

The Construction Industry Research and Information Association (CIRIA) ~ established in 1960 as the Civil Engineering Research Council (CERC) with the objective of financing research with money raised from industry. In 1967 it was renamed, thereafter as a non-profit making company owned by other companies, universities, government departments and various other public sector organisations. All subscriptions and fee income is invested into seminars, training and research.

Main areas of activity:

- Research - industry wide covering construction and the environment.
- Publications - a catalogue of over 600 titles.
- Training - short courses, seminars and conferences.
- Networks - support processes at training events, seminars and workshops.
- Information services - newsletters, bulletins and a biannual magazine.

CI/SfB System ~ a coded filing system for the classification and storing of building information and data. It was created in Sweden under the title of Samarbetskommittén för Byggnadsfrågor and was introduced into this country in 1961 by the RIBA. In 1968 the CI (Construction Index) was added to the system which is used nationally and recognised throughout the construction industry. The system consists of five sections called tables which are subdivided by a series of letters or numbers and these are listed in the CI/SfB index book to which reference should always be made in the first instance to enable an item to be correctly filed or retrieved.

### Table 0 - Physical Environment

This table contains ten sections 0 to 9 and deals mainly with the end product (i.e. the type of building.) Each section can be further subdivided (e.g. 21, 22, etc.) as required.

### Table 1 - Elements

This table contains ten sections numbered (--) to (9-) and covers all parts of the structure such as walls, floors and services. Each section can be further subdivided (e.g. 31, 32, etc.) as required.

### Table 2 - Construction Form

This table contains 25 sections lettered A to Z (O being omitted) and covers construction forms such as excavation work, blockwork, cast in-situ work etc., and is not subdivided but used in conjunction with Table 3.

### Table 3 - Materials

This table contains 25 sections lettered a to z (l being omitted) and covers the actual materials used in the construction form such as metal, timber, glass, etc., and can be subdivided (e.g. n1, n2, etc.) as required.

### Table 4 - Activities and Requirements

This table contains 25 sections lettered (A) to (Z), (O being omitted) and covers anything which results from the building process such as shape, heat, sound, etc. Each section can be further subdivided ((M1), (M2) etc.) as required.

CPI System of Coding ~ the Coordinated Project Information initiative originated in the 1970s in response to the need to establish a common arrangement of document and language communication, across the varied trades and professions of the construction industry. From this evolved the Common Arrangement of Work Sections (CAWS) first published in 1987. Since then it has been effectively used with the publication of the Standard Method of Measurement 7th edition (SMM 7), the National Building Specification (NBS) and the Drawings Code. (Note: The NBS is also produced in CI/SfB format.) Later editions of CAWS are aligned with Uniclass.

The arrangement in all documents is a coordination of alphabetic sections, corresponding to elements of work, the purpose being to avoid mistakes, omissions and other errors which have in the past occurred between drawings, specification and bill of quantities descriptions.

The coding is a combination of letters and numbers, spanning three levels:

Level 1 has 24 headings from A to Z (omitting I and O). Each heading relates to part of the construction process, such as groundwork (D), Joinery (L), surface finishes (M), etc.

Level 2 is a subheading, which in turn is subgrouped numerically into different categories. So, for example, Surface Finishes is sub-headed; Plaster, Screeds, Painting, etc. These subheadings are then extended further, thus Plaster becomes; Plastered/Rendered Coatings, Insulated Finishes, Sprayed Coatings, etc.

Level 3 is the work section subgrouped from level 2, to include a summary of inclusions and omissions.

As an example, an item of work coded M21 signifies:

M - Surface finishes  
2 - Plastered coatings  
1 - Insulation with rendered finish

The coding may be used to:

- (a) simplify specification writing
- (b) reduce annotation on drawings
- (c) rationalise traditional taking-off methods

## Uniclass System of Coding

Uniclass ~ the Unified Classification for the Construction Industry was created in the 1990s by the Construction Project Information Committee (CPIC) [see below] and first published by the RIBA in 1997.

Purpose ~ to organise product literature and project information into a structured library format. It incorporates the Common Arrangement of Work Sections (CAWS) and the Electronic Product Information Cooperation (EPIC) system of structuring product literature and information.

Composition ~ comprises 15 tables (coded A to Q, I and O omitted), each table an independent classification of specific information that can be used solely or in combination with other table references where subject matter is complex or diverse.

EPIC ~ an established European coding system for technical product literature and information. Widely used across continental Europe but less so in the UK. Favoured by some product manufacturers in their presentation of data to architects and engineers.

Product literature label showing CI/SfB, Uniclass and EPIC notation ~

Uniclass L5214	EPIC E312
CI/SfB  (47)                      Ne5	

CPIC members ~

Construction Confederation (CC).

Royal Institute of British Architects (RIBA).

Chartered Institute of Architectural Technologists (CIAT).

Chartered Institution of Building Services Engineers (CIBSE).

Royal Institution of Chartered Surveyors (RICS).

Institution of Civil Engineers (ICE).

BIM ~ terminology specific to the construction industry as a summary description for collating, organising and managing technical information and project data.

Development and Background ~ information modelling is not new in concept. The practice of creating and maintaining libraries of readily accessible, searchable and transferable building information has produced several orderly and systematic arrangements. Not least the established coding systems outlined on the preceding three pages; namely, CI/SfB, CPI (incorporating CAWS, NBS and SMM7) and Uniclass. As independent systems these have their limitations. Certain parts are becoming oversubscribed as new technologies and processes evolve. The CI/SfB alpha-numeric mix of letters, numbers and brackets is not entirely compatible with digital formatting. Used in combination, there is cross correlation and common identification of some coded classifications, but there remains an element of variation and disparity. Unification of data formatting and presentation is an objective that BIM seeks to address to simplify information transfer between projects and more widely across the industry.

Structured data can be presented within three categories:

- Building Information Modelling ~ as outlined above, a business information process providing access for all involved with a construction project from client through design, assembly and after care.
- Building Information Model ~ digital representation of the business process that provides structured data management to include schedules and reports in spreadsheet format for the various stages of a project's development.
- Building Information Management ~ the organisation and administrative strategy for control of a project using data from the building information model. A communication process that applies from initial concept and inception of a building, throughout the construction process and with regard to the long term maintenance and intended life span of a completed asset.

Project information and data classification systems:

**BPIC** ~ Building Project Information Committee, formed in 1987. Produced the Common Arrangement of Work Sections (CAWS) as a simplified specification and referencing system. Renamed CPIC, Construction Project Information Committee in the mid 90s. In 1997 introduced Uniclass as a structured product literature and information classification.

**BS ISO 12006-2:** (Building construction. Organisation of information about construction works. Framework for classification of information) ~ guidance on information exchange, data organisation and classification systems.

**CAWS** ~ a letter and number (alpha-numeric) coded notation of work sections, groups and sub-groups produced primarily to coordinate entries in specifications and bills of quantities. Compatible with SMM7, NBS and NES. See page 79.

**CI/SfB** ~ introduced to the UK in 1961 with revisions in 1968 and 1976. The forerunner to subsequent indexing systems, it has gained wide acceptance across the construction industry. Now functions mainly as library referencing of product literature. Its bracketed combinations of letters and numbers limit its application to digital technology. See page 78.

**COBie** ~ Construction Operations Building information exchange. A shared data standard management system applied to the intended life span of a building. It provides a spreadsheet source of data based on reports and models relating to existing completed projects. From this data storage facility, structured information can be transferred and used for planning and managing subsequent similar building types.

**EPIC** ~ Electronic Product Information Cooperation. Popular across continental Europe as a coding system for manufacturers' product literature. Used by some UK architectural and engineering practices as a basis for data presentation. See page 80.

continued . . . . .

**NBS** ~ National Building Specification, the UK national standard specification for building work. Part of RIBA Enterprises Ltd. NBS also have other information resource products including the Construction Information Service (CIS) produced jointly with IHS, Information Handling Services.

**NBS Create** ~ a data standard for documenting and sharing structured information based on existing work schedules and manufacturers' product details. Links NBS to building information modelling.

**NBS National BIM Library** ~ an information resource covering all aspects of the building fabric and elements of construction. The content of the library is based on "... proprietary and pre-configured generic objects .....

**NES** ~ National Engineering Specification for building services projects. Standard, concise specifications endorsed by CIBSE, Chartered Institution of Building Services Engineers and BSRIA, Building Services Research and Information Association.

**RIBA Plan of Work** ~ established in 1964 by the Royal Institute of British Architects as a methodical procedure for the design team to apply to building projects. Its 'work stages' and 'key tasks' have become universally accepted by the other building professions as a planning model, as guidance for progressing projects and for processing contract procurement. Subsequent revisions, notably in 1998, 2007 and 2011 have retained its relevance.

**SMM** ~ Standard Method of Measurement, originated in 1922 with several revisions since then. It is used mainly by quantity surveyors as a model for producing bills of quantities for builders' estimators to price when tendering for work. The SMM's rules for measurement are used throughout the world. In current format it is written to comply with CPI guidance (see page 79). Maintained by the RICS, Royal Institution of Chartered Surveyors.

**Uniclass** ~ first produced in 1997 and subsequently revised, provides a tabulated system of classifications that represent project information and product literature. Incorporates CAWS and EPIC. See page 80.



*This page intentionally left blank*

## 2 SITE WORKS

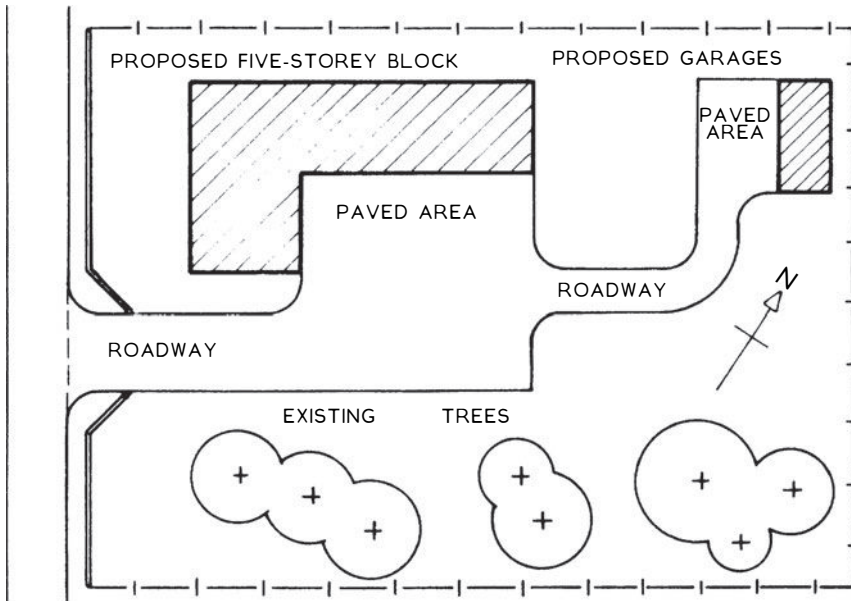

SITE MEASUREMENT  
SITE INVESTIGATIONS  
SOIL INVESTIGATION  
SOIL ASSESSMENT AND TESTING  
SITE LAYOUT CONSIDERATIONS  
SITE SECURITY  
SITE LIGHTING AND ELECTRICAL SUPPLY  
SITE OFFICE ACCOMMODATION  
SITE HEALTH AND WELFARE PROVISION  
MATERIALS STORAGE  
MATERIALS TESTING  
TIMBER DECAY AND TREATMENT  
PROTECTION ORDERS FOR TREES AND SHRUBS  
LOCATING PUBLIC UTILITY SERVICES  
SETTING OUT  
LEVELS AND ANGLES  
ROAD CONSTRUCTION  
TUBULAR SCAFFOLDING AND SCAFFOLDING SYSTEMS  
SHORING SYSTEMS  
DEMOLITION

## Site Survey

Site Analysis – prior to purchasing a building site it is essential to conduct a thorough survey to ascertain whether the site characteristics suit the development concept. The following guidance forms a basic checklist:

- \* Refer to Ordnance Survey maps to determine adjacent features, location, roads, facilities, footpaths and rights of way.
- \* Conduct a measurement survey to establish site dimensions and levels.
- \* Observe surface characteristics, i.e. trees, steep slopes, existing buildings, rock outcrops, wells.
- \* Inquire of local authority whether preservation orders affect the site and if it forms part of a conservation area.
- \* Investigate subsoil. Use trial holes and borings to determine soil quality and water table level.
- \* Consider flood potential, possibilities for drainage of water table, capping of springs, filling of ponds, diversion of streams and rivers.
- \* Consult local utilities providers for underground and overhead services, proximity to site and whether they cross the site.
- \* Note suspicious factors such as filled ground, cracks in the ground, subsidence due to mining and any cracks in existing buildings.
- \* Regard neighbourhood scale and character of buildings with respect to proposed new development.
- \* Decide on best location for building (if space permits) with regard to 'cut and fill', land slope, exposure to sun and prevailing conditions, practical use and access.

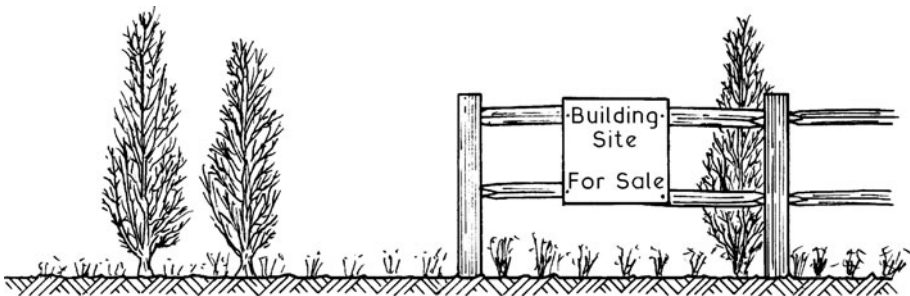

See also desk and field studies on page 91.

Irregular plan surface areas ~ these are typical of many building sites, with odd-shaped boundaries and directional changes.

Methods for measurement ~ modern instruments and computational techniques, including photogrammetry, can provide accurate calculation of site areas. Traverse data coordinates from theodolite readings can also be used. Fieldwork measurements and simple calculations are an adequate and economic means for obtaining reasonable area estimates for most modest size sites. These can be undertaken from scaled maps or preferably from a scaled drawing of the area following a measured survey.

Estimates based on scaled site drawings ~

- Gridded tracing paper superimposed over the plotted area and the number of squares counted.

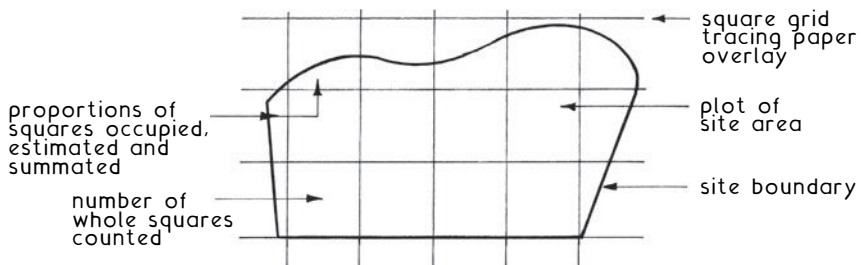

E.g. If each square scaled is 10m × 10m (100m<sup>2</sup>), the approximate site area is:

8 full squares at 100m<sup>2</sup> = 800m<sup>2</sup>

3.5 squares made up of proportional squares = 350m<sup>2</sup>

Total area is approximately 800m<sup>2</sup> + 350m<sup>2</sup> = 1150m<sup>2</sup>

- Give and take for irregular boundaries.

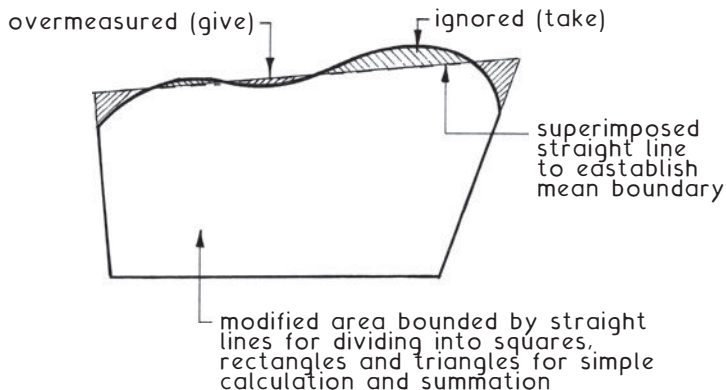

## Site Measurement — Simpson's Rule

Thomas Simpson (1710–1761) ~ a British mathematician who derived interpolation and numerical methods of integration for calculation of areas under curves.

Simpson's rule ~

$$A = w [(h_1 + h_7) + 4(h_2 + h_4 + h_6) + 2(h_3 + h_5)] \div 3$$

Where: A = estimate of site area (m<sup>2</sup>)

w = width or equal distances between ordinates (m)

h = height or length of parallel ordinates (m)

Note: requires an odd number of ordinates and an even number of areas.

E.g.

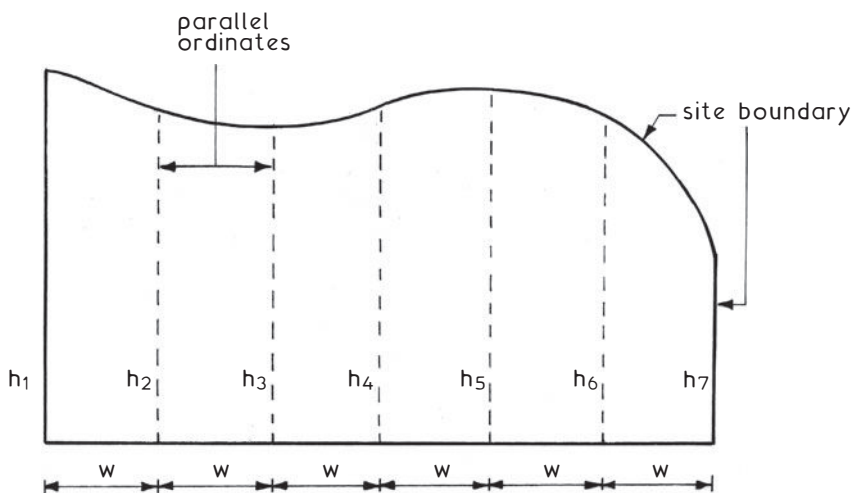

If,  $h_1 = 40\text{ m}$ ,  $h_2 = 36\text{ m}$ ,  $h_3 = 34\text{ m}$ ,  $h_4 = 34\text{ m}$ ,  $h_5 = 38\text{ m}$ ,  $h_6 = 36\text{ m}$ , and  $h_7 = 20\text{ m}$ .  $w = 12\text{ m}$ .

$$A = 12 [(40 + 20) + 4(36 + 36 + 36) + 2(34 + 38)] \div 3$$

$$A = 12 [60 + 432 + 144] \div 3$$

$$A = 12 \times 636 \div 3$$

$$A = 2544\text{ m}^2$$

Note: An area  $100\text{ m} \times 100\text{ m}$  ( $10,000\text{ m}^2$ ) = 1 hectare (1ha).

In the above calculation,  $2544\text{ m}^2 = 0.2544\text{ ha}$ .

In imperial measurement there are approximately 2.5 (2.471) acres to 1ha. Therefore  $0.2544\text{ ha} = 0.6286\text{ acres}$ .

Method ~ a little less accurate than Simpson's rule as it does not assume a curved boundary, but it is adequate in most situations for providing a reasonable estimate of site area. As with Simpson's rule, the site plan area is divided into several parallel strips of equal width (w).

E.g.

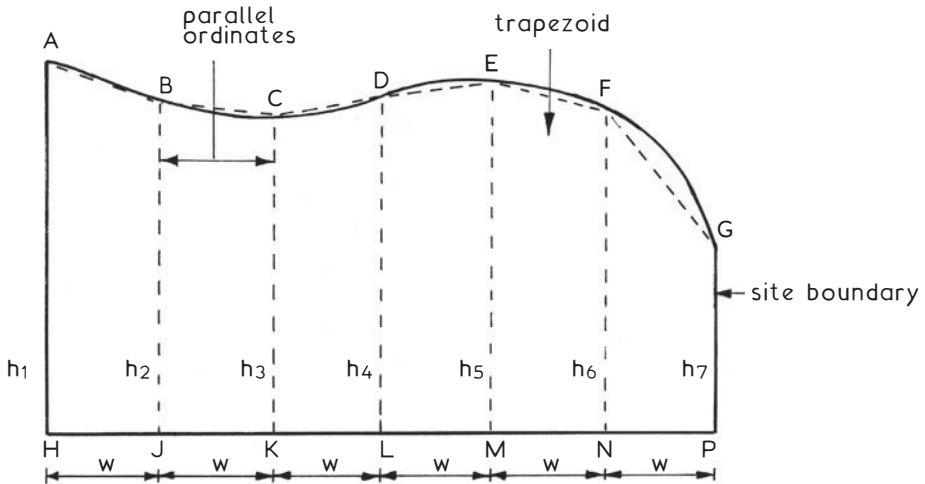

$$\text{Area of trapezoid ABHJ} = \left[ \frac{(h_1 + h_2)}{2} \right] \times w$$

$$\text{Area of trapezoid BCJK} = \left[ \frac{(h_2 + h_3)}{2} \right] \times w$$

and so on until:

$$\text{Area of trapezoid FGPN} = \left[ \frac{(h_6 + h_7)}{2} \right] \times w$$

Therefore the total plot area (A) will be the sum of the trapezoids expressed as:

$$A = w \left\{ \left[ \frac{(h_1 + h_7)}{2} \right] + h_2 + h_3 + h_4 + h_5 + h_6 \right\}$$

E.g. Using the site dimensions from the previous page:

$$A = 12 \left\{ \left[ \frac{(40 + 20)}{2} \right] + 36 + 34 + 36 + 38 + 36 \right\}$$

$$A = 12 \{ 30 + 36 + 34 + 36 + 38 + 36 \}$$

$$A = 12 \times 210$$

$$A = 2520\text{m}^2$$

A fair comparison with the same area calculation of 2544m<sup>2</sup> using Simpson's rule on the previous page. Greater accuracy can be achieved by reducing the ordinate widths (w).

# Site Investigations

Site Investigation For New Works ~ the basic objective of this form of site investigation is to collect systematically and record all the necessary data which will be needed or will help in the design and construction processes of the proposed work. The collected data should be presented in the form of fully annotated and dimensioned plans and sections. Anything on adjacent sites which may affect the proposed works or conversely anything appertaining to the proposed works which may affect an adjacent site should also be recorded.

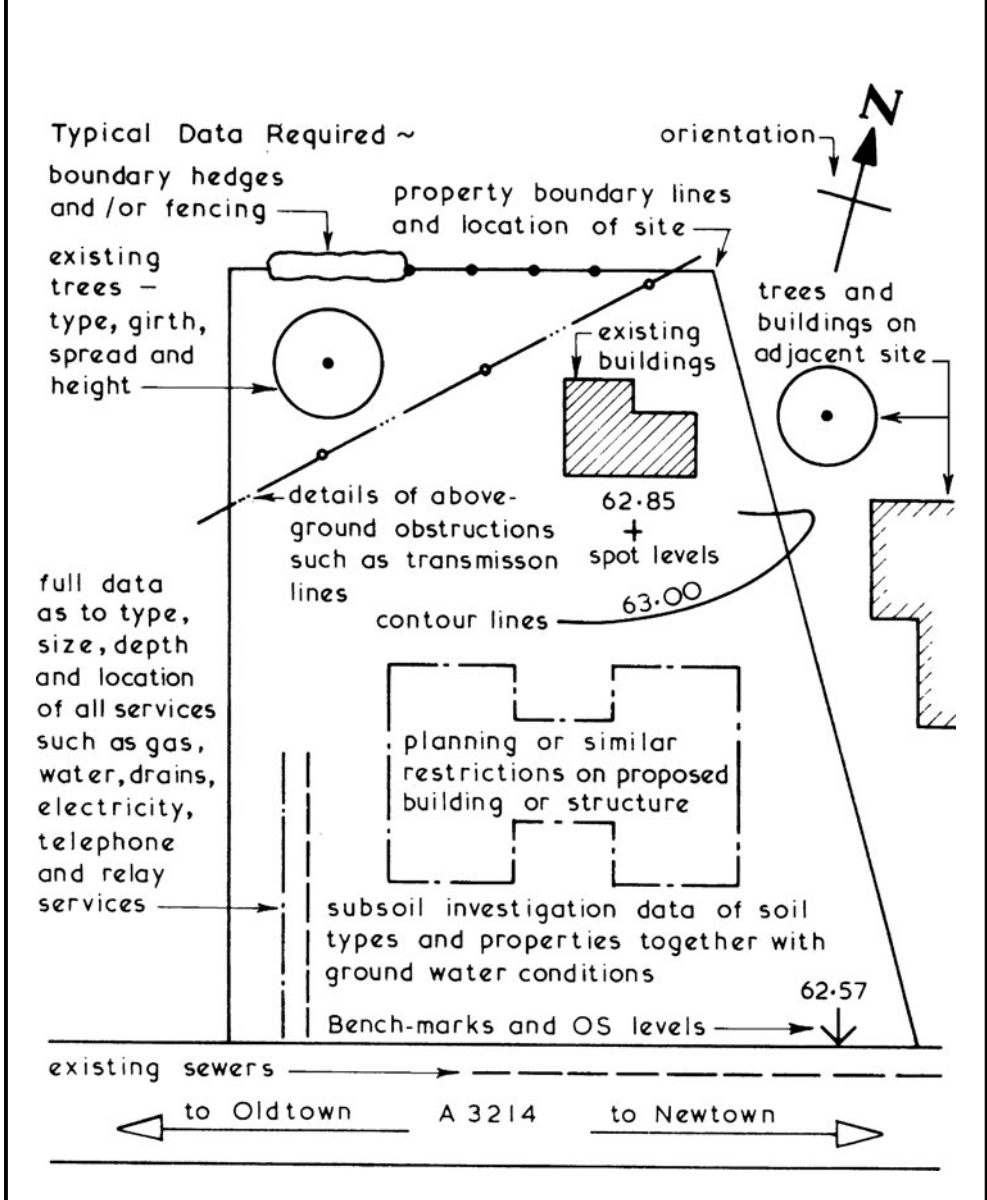

### Procedures ~

1. Desk study
2. Field study or walk-over survey
3. Laboratory analysis (see pages 100-101 and 106-111)

### Desk Study ~ collection of known data, to include:

- Ordnance Survey maps - historical and modern, note grid reference.
- Geological maps - subsoil types, radon risk.
- Site history - green-field/brown-field.
- Previous planning applications/approvals.
- Current planning applications in the area.
- Development restrictions - conservation orders.
- Utilities - location of services on and near the site.
- Aerial photographs.
- Ecology factors - protected wildlife.
- Local knowledge - anecdotal information/rights of way.
- Proximity of local land-fill sites - methane risk.

### Field Study ~ intrusive visual and physical activity to:

- Establish site characteristics from the desk study.
- Assess potential hazards to health and safety.
- Appraise surface conditions:
  - \* Trees - preservation orders.
  - \* Topography and geomorphological mapping.
- Appraise ground conditions:
  - \* Water table.
  - \* Flood potential - local water courses and springs.
  - \* Soil types.
  - \* Contamination - vegetation die-back.
  - \* Engineering risks - ground subsidence, mining, old fuel tanks.
  - \* Financial risks - potential for the unforeseen.
- Take subsoil samples and conduct in-situ tests.
- Consider the need for subsoil exploration, trial pits and boreholes.
- Appraise existing structures:
  - \* Potential for reuse/refurbishment.
  - \* Archaeological value/preservation orders.
  - \* Demolition - costs, health issues (e.g. asbestos).



## Trial Pits and Hand Auger Holes

Purpose ~ primarily to obtain subsoil samples for identification, classification and ascertaining the subsoil's characteristics and properties. Trial pits and augered holes may also be used to establish the presence of any geological faults and the upper or lower limits of the water table.

### Typical Details ~

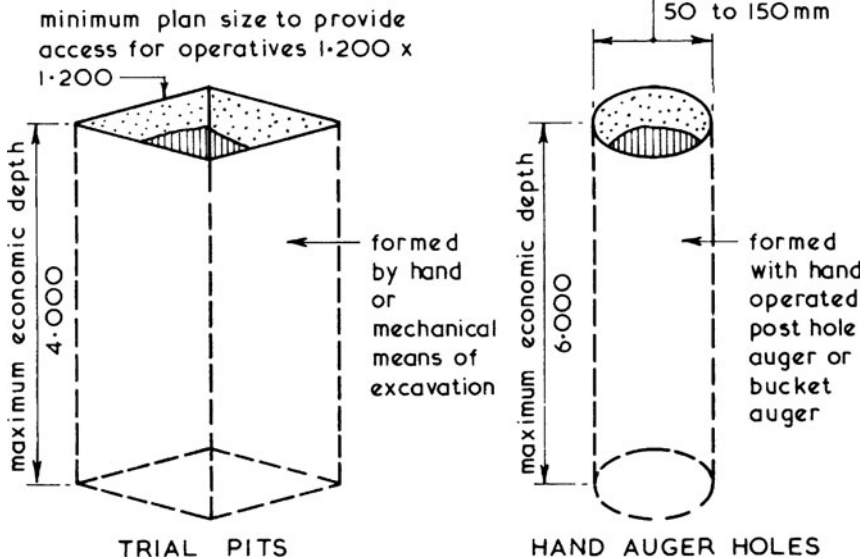

### General use ~

dry ground which requires little or no temporary support to sides of excavation.

### Subsidiary use~

to expose and/or locate underground services.

### Advantages ~

subsoil can be visually examined in-situ - both disturbed and undisturbed samples can be obtained.

### General use ~

dry ground but liner tubes could be used if required to extract subsoil samples at a depth beyond the economic limit of trial holes.

### Advantages ~

generally a cheaper and simpler method of obtaining subsoil samples than the trial pit method.

Trial pits and holes should be sited so that the subsoil samples will be representative but not interfering with works.

Site Investigation ~ this is an all-embracing term covering every aspect of the site under investigation.

Soil Investigation ~ specifically related to the subsoil beneath the site under investigation and could be part of or separate from the site investigation.

Purpose of Soil Investigation ~

1. Determine the suitability of the site for the proposed project.
2. Determine an adequate and economic foundation design.
3. Determine the difficulties which may arise during the construction process and period.
4. Determine the occurrence and/or cause of all changes in subsoil conditions.

The above purposes can usually be assessed by establishing the physical, chemical and general characteristics of the subsoil by obtaining subsoil samples which should be taken from positions on the site which are truly representative of the area but are not taken from the actual position of the proposed foundations. A series of samples extracted at the intersection points of a 20·000 square grid pattern should be adequate for most cases.

Soil Samples ~ these can be obtained as disturbed or as undisturbed samples.

Disturbed Soil Samples ~ these are soil samples obtained from boreholes and trial pits. The method of extraction disturbs the natural structure of the subsoil but such samples are suitable for visual grading, establishing the moisture content and some laboratory tests. Disturbed soil samples should be stored in labelled airtight jars.

Undisturbed Soil Samples ~ these are soil samples obtained using coring tools which preserve the natural structure and properties of the subsoil. The extracted undisturbed soil samples are labelled and laid in wooden boxes for dispatch to a laboratory for testing. This method of obtaining soil samples is suitable for rock and clay subsoils but difficulties can be experienced in trying to obtain undisturbed soil samples in other types of subsoil.

The test results of soil samples are usually shown on a drawing which gives the location of each sample and the test results in the form of a hatched legend or section.

Ref. BSEN 1997-2: Geotechnical design. Ground investigation and testing.

# Soil Investigation

Depth of Soil Investigation ~ before determining the actual method of obtaining the required subsoil samples the depth to which the soil investigation should be carried out must be established. This is usually based on the following factors:

1. Proposed foundation type.
2. Pressure bulb of proposed foundation.
3. Relationship of proposed foundation to other foundations.

Typical Examples ~

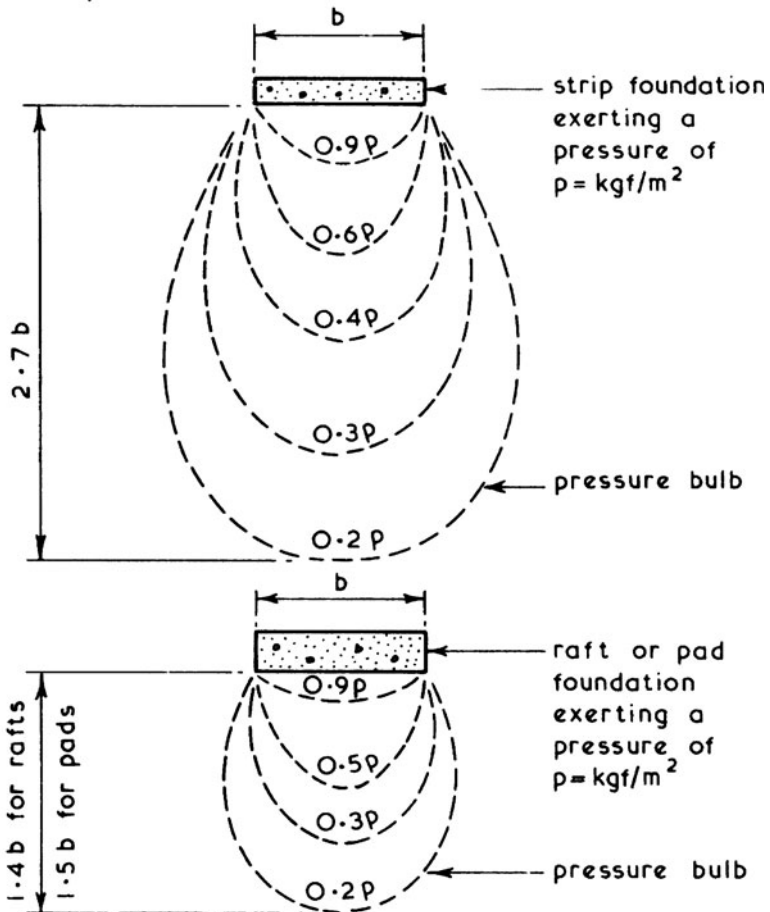

Pressure bulbs of less than 20% of original loading at foundation level can be ignored - this applies to all foundation types.

NB. For further examples see next page.

Typical Examples of Depth of Soil Investigation Considerations ~

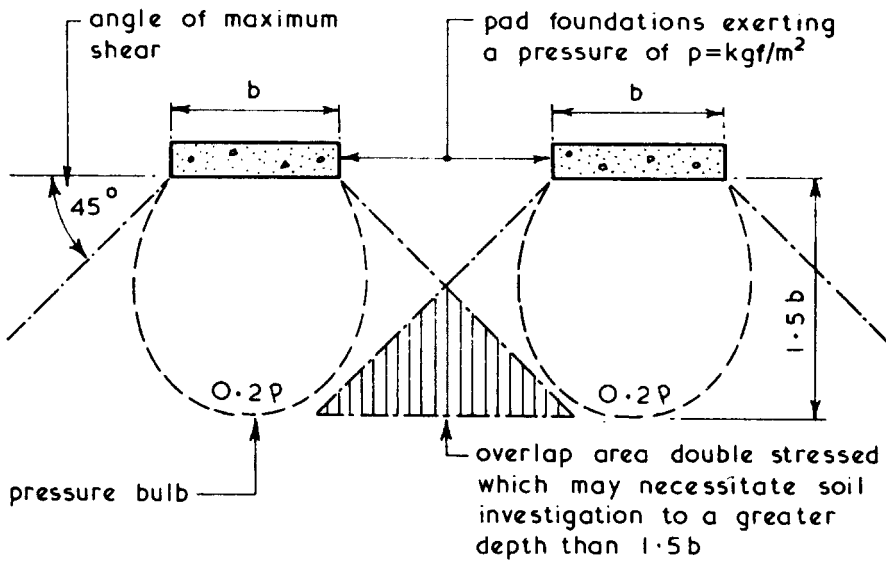

FOUNDATIONS CLOSE TO ONE ANOTHER

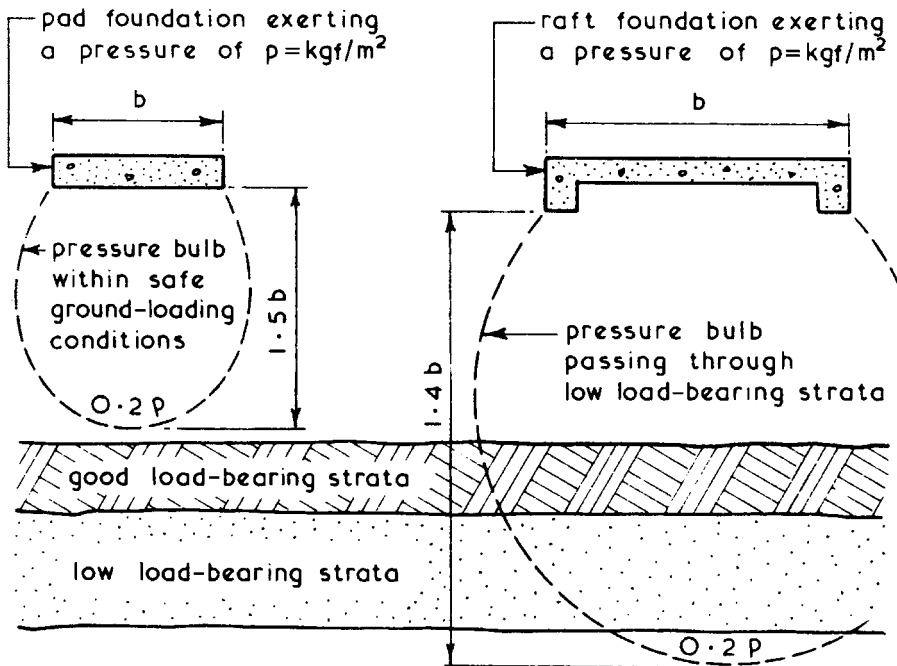

DIFFERENT FOUNDATION TYPES ON THE SAME SITE

# Soil Investigation

Soil Investigation Methods ~ method chosen will depend on several factors:

1. Size of contract.
2. Type of proposed foundation.
3. Type of sample required.
4. Types of subsoils which may be encountered.

As a general guide the most suitable methods in terms of investigation depth are:

1. Foundations up to 3.000 deep - trial pits.
2. Foundations up to 30.000 deep - borings.
3. Foundations over 30.000 deep - deep borings and in-situ examinations from tunnels and/or deep pits.

Typical Trial Pit Details ~

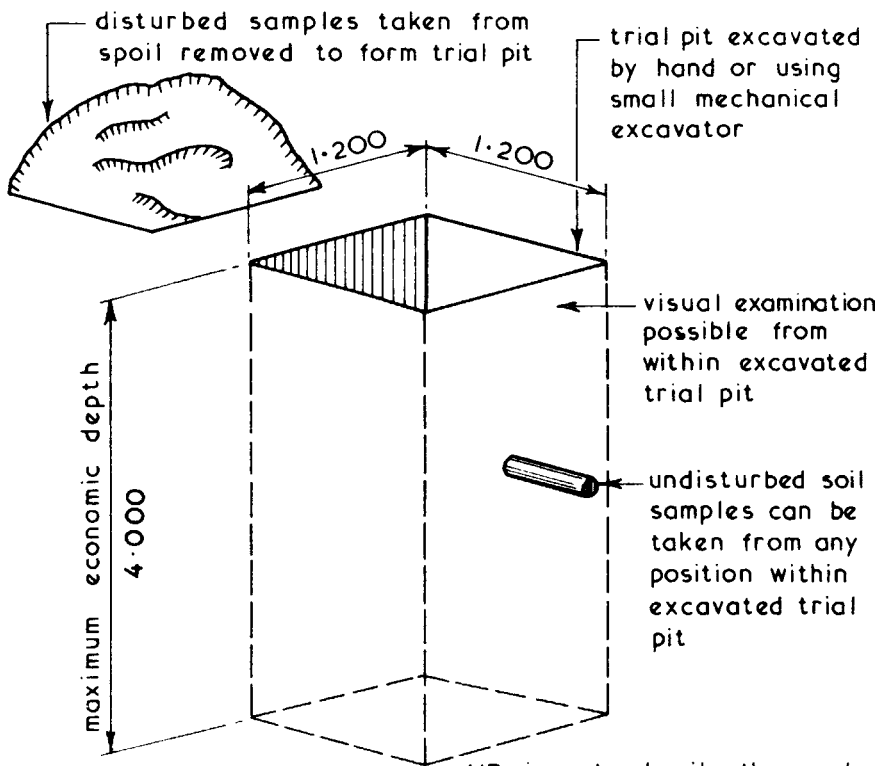

NB. For details of other soil investigation methods see the next two pages.

NB. in wet subsoils the need for timbering to the sides of the trial pit and the need for a pump may outweigh any advantages.

## Boring Methods to Obtain Disturbed Soil Samples:

1. Hand or Mechanical Auger - suitable for depths up to 3.000 using a 150 or 200mm diameter flight auger.
2. Mechanical Auger - suitable for depths over 3.000 using a flight or Cheshire auger - a liner or casing is required for most granular soils and may be required for other types of subsoil.
3. Sampling Shells - suitable for shallow to medium depth borings in all subsoils except rock.

## Typical Details ~

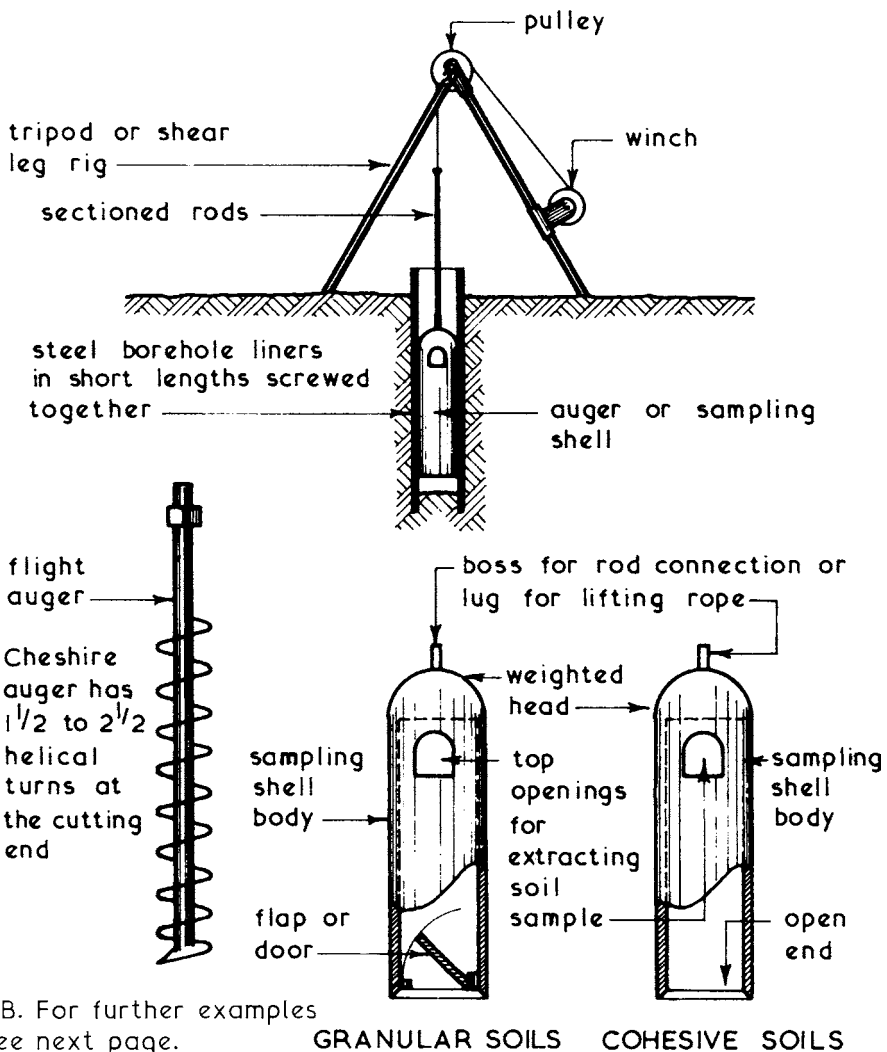

## Soil Investigation

Wash Boring ~ this is a method of removing loosened soil from a borehole using a strong jet of water or bentonite which is a controlled mixture of fullers earth and water. The jetting tube is worked up and down inside the borehole, the jetting liquid disintegrates the subsoil which is carried in suspension up the annular space to a settling tank. The settled subsoil particles can be dried for testing and classification. This method has the advantage of producing subsoil samples which have not been disturbed by the impact of sampling shells; however, it is not suitable for large gravel subsoils or subsoils which contain boulders.

Typical Wash Boring Arrangement ~

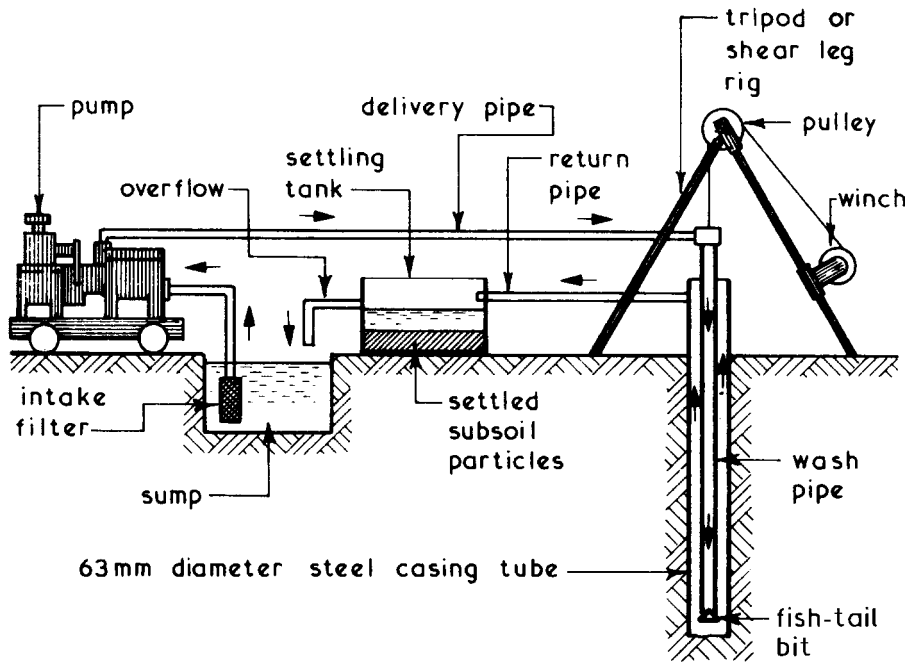

Mud-rotary Drilling ~ this is a method which can be used for rock investigations where bentonite is pumped in a continuous flow down hollow drilling rods to a rotating bit. The cutting bit is kept in contact with the bore face and the debris is carried up the annular space by the circulating fluid. Core samples can be obtained using coring tools.

Core Drilling ~ water or compressed air is jetted down the borehole through a hollow tube and returns via the annular space. Coring tools extract continuous cores of rock samples which are sent in wooden boxes for laboratory testing.

Borehole Data ~ the information obtained from trial pits or boreholes can be recorded on a pro forma sheet or on a drawing showing the position and data from each trial pit or borehole thus:

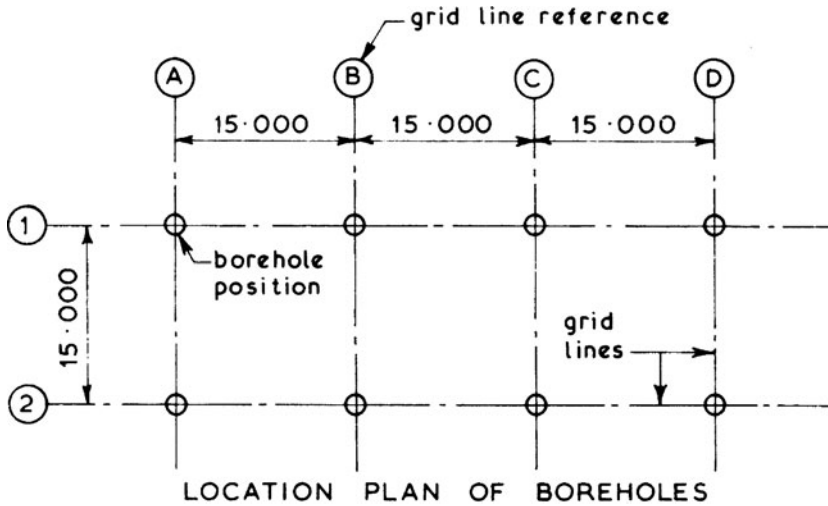

Boreholes can be taken on a 15.000 to 20.000 grid covering the whole site or in isolated positions relevant to the proposed foundation(s).

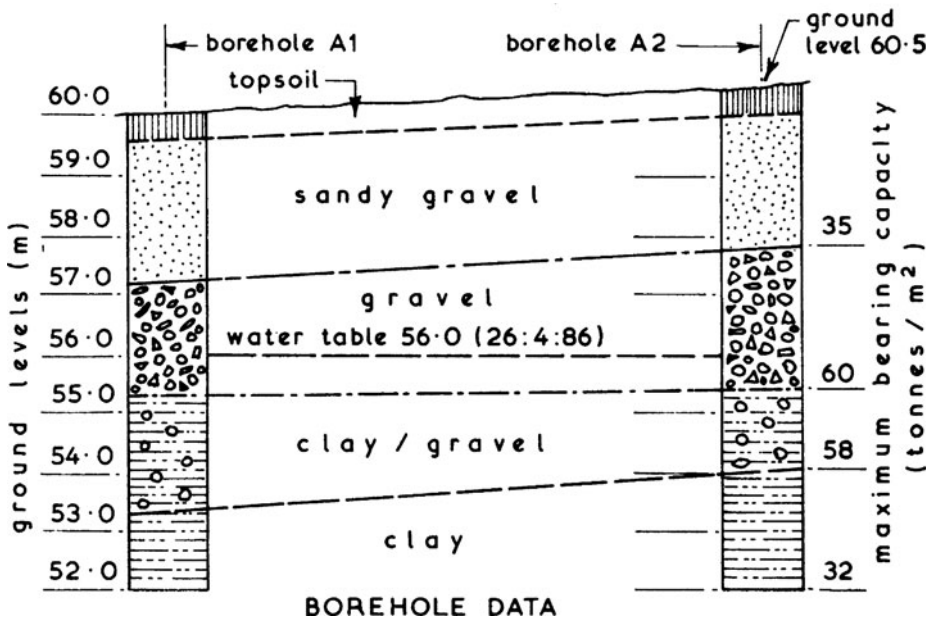

As a general guide the cost of site and soil investigations should not exceed 1% of estimated project costs.



## Soil Assessment and Testing

Soil Assessment ~ prior to designing the foundations for a building or structure the properties of the subsoil(s) must be assessed. These processes can also be carried out to confirm the suitability of the proposed foundations. Soil assessment can include classification, grading, tests to establish shear strength and consolidation. The full range of methods for testing soils is given in BS 1377: Methods of test for soils for civil engineering purposes.

Classification ~ soils may be classified in many ways such as geological origin, physical properties, chemical composition and particle size. It has been found that the particle size and physical properties of a soil are closely linked and are therefore of particular importance and interest to a designer.

Particle Size Distribution ~ this is the percentages of the various particle sizes present in a soil sample as determined by sieving or sedimentation. BS 1377 divides particle sizes into groups as follows:

Gravel particles - over 2mm

Sand particles - between 2mm and 0.06mm

Silt particles - between 0.06mm and 0.002mm

Clay particles - less than 0.002mm

The sand and silt classifications can be further divided thus:

CLAY	SILT			SAND			GRAVEL
	fine	medium	coarse	fine	medium	coarse	
0.002	0.006	0.02	0.06	0.2	0.6	2	>2

The results of a sieve analysis can be plotted as a grading curve thus:

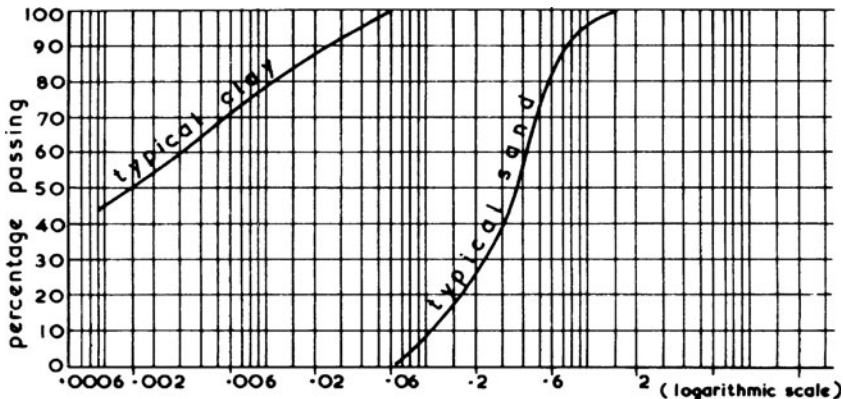

Triangular Chart ~ this provides a general classification of soils composed predominantly from clay, sand and silt. Each side of the triangle represents a percentage of material component. Following laboratory analysis, a sample's properties can be graphically plotted on the chart and classed accordingly.

E.g. Sand - 70%, Clay - 10% and Silt - 20% = Sandy Loam.

Note:

Silt is very fine particles of sand, easily suspended in water.

Loam is very fine particles of clay, easily dissolved in water.

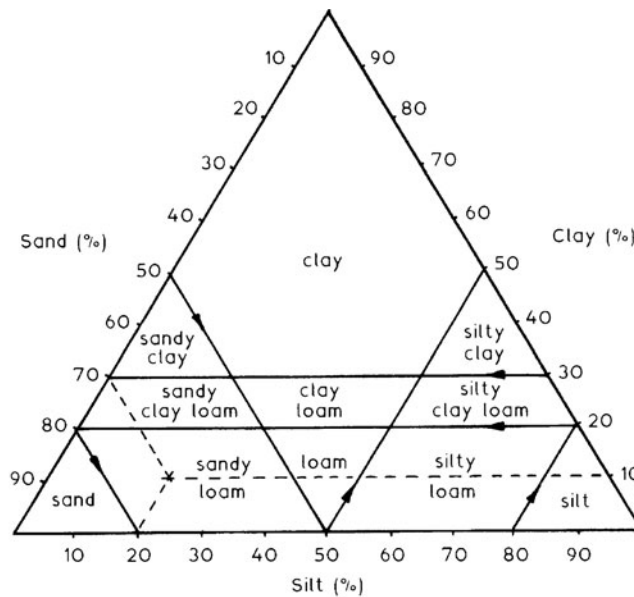

Standard soil symbols ~

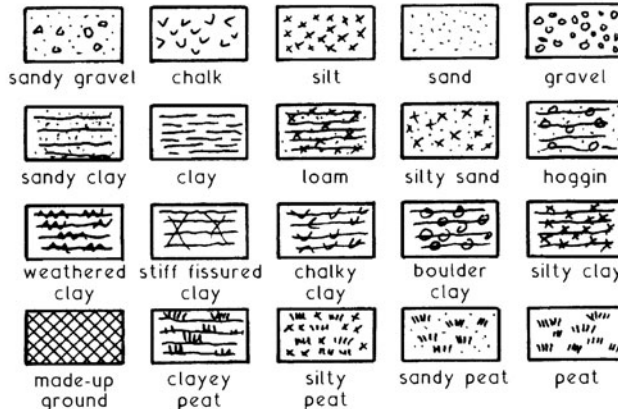

## Soil Assessment and Testing

Plate Loading Test ~ otherwise known as the plate bearing test. By comparison with the more scientific testing procedures described on the next few pages, this test is rudimentary in simplicity. However, it is a cost effective application as a preliminary means for assessing the bearing capacity of unknown soil conditions.

Procedure ~ a trial hole is excavated to the anticipated depth of foundation bearing. Within the excavation is placed a steel test plate of proportionally smaller area than the finished foundation. This plate is then loaded with a proportionally smaller loading than the building load and settlement monitored to establish a building load/soil settlement relationship.

Traditionally, heavy weights of steel billets, concrete blocks, bricks or sandbags were mounted over the test plate gradually increasing the load as the relative settlement was recorded. This somewhat precarious material intensive procedure is superseded by using a hydraulic jack between test plate and a kentledge forming a platform for dense objects such as concrete blocks as shown below.

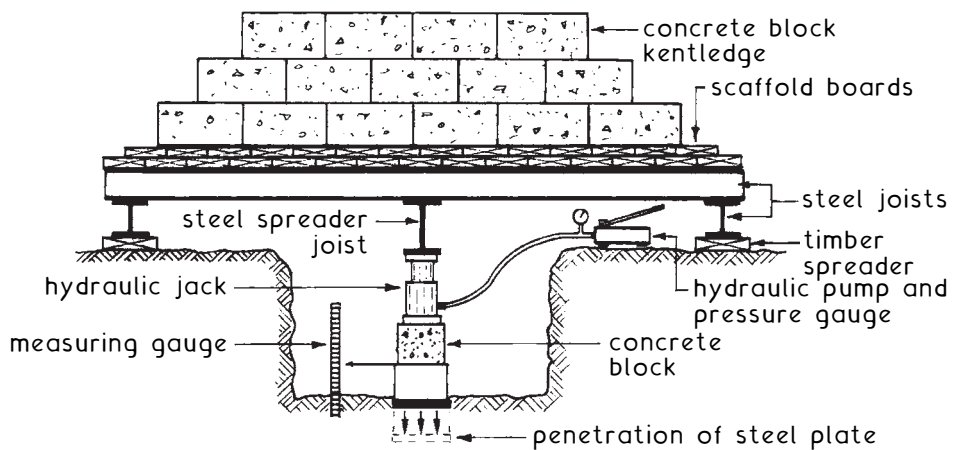

Typical test results shown on the next page.

## Plate Loading Test Results ~

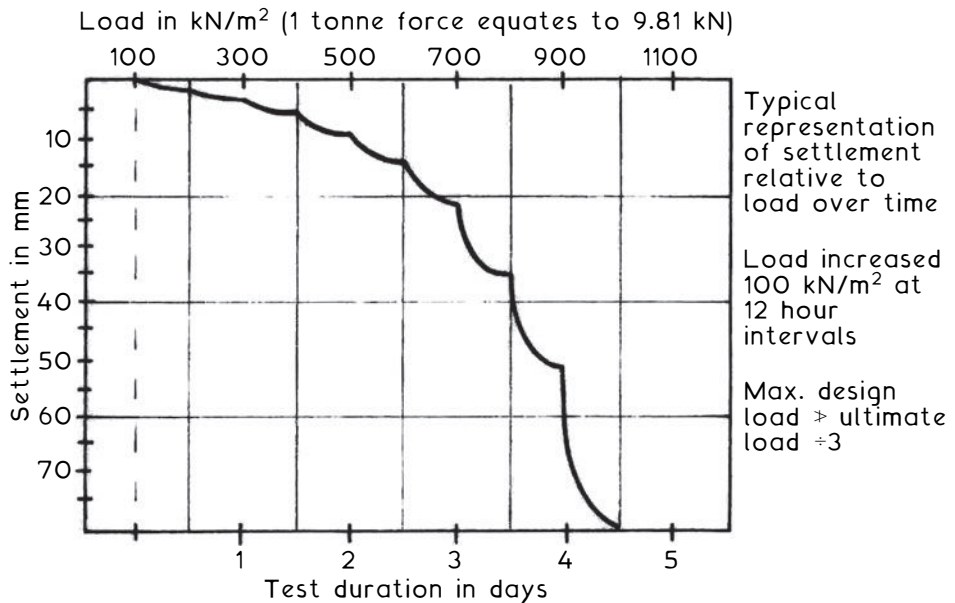

Limitations ~ although useful for determining subsoil properties at shallow depths, this test is limited to a relatively small area of test plate. As shown on pages 94 and 95, the extent of pressure bulb under the test load will be less than the pressure bulb beneath the actual foundation. Therefore this test does not account for the underlying soil conditions beyond the pressure bulb sphere of the test plate.

## Plate Loading Test Numerical Example ~

A steel column pad foundation with anticipated design dimensions of one square metre supporting a load of 30 tonnes. Using a proportionally reduced test plate of 25% foundation area ( $500 \text{ mm} \times 500 \text{ mm}$ ) this will be required to carry  $30 \div 4$  tonnes, i.e. 7.5 tonnes. The usual safety margin with these tests is a factor of 3, therefore  $7.5 \text{ tonnes} \times 3$  will be 22.5 tonnes or 225 kN ultimate loading to be applied.

## Soil Assessment and Testing

Site Soil Tests ~ these tests are designed to evaluate the density or shear strength of soils and are very valuable since they do not disturb the soil under test. Three such tests are the standard penetration test, the vane test and the unconfined compression test, all of which are fully described in BS 1377; Methods of test for soils for civil engineering purposes.

Standard Penetration Test ~ this test measures the resistance of a soil to the penetration of a split spoon or split barrel sampler driven into the bottom of a borehole. The sampler is driven into the soil to a depth of 150 mm by a falling standard weight of 65 kg falling through a distance of 760 mm. The sampler is then driven into the soil a further 300 mm and the number of blows counted up to a maximum of 50 blows. This test establishes the relative density of the soil.

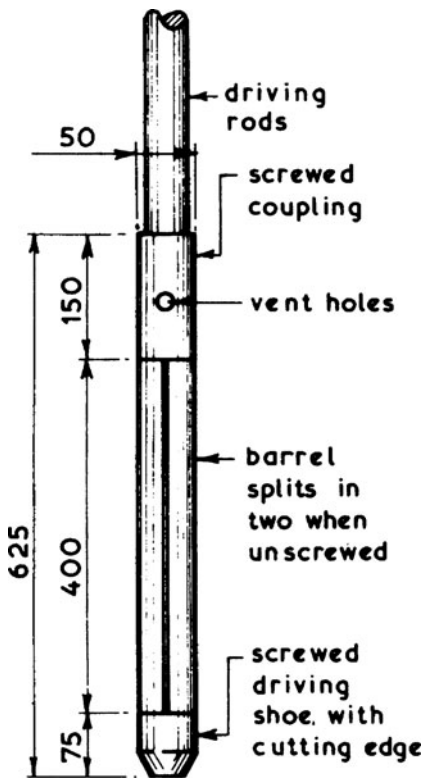

**TYPICAL SPLIT  
BARREL SAMPLER**

### TYPICAL RESULTS

Non-cohesive soils:

No. of Blows	Relative Density
0 to 4	very loose
4 to 10	loose
10 to 30	medium
30 to 50	dense
50+	very dense

Cohesive soils:

No. of Blows	Relative Density
0 to 2	very soft
2 to 4	soft
4 to 8	medium
8 to 15	stiff
15 to 30	very stiff
30+	hard

The results of this test in terms of number of blows and amounts of penetration will need expert interpretation.

Vane Test ~ this test measures the shear strength of soft cohesive soils. The steel vane is pushed into the soft clay soil and rotated by hand at a constant rate. The amount of torque necessary for rotation is measured and the soil shear strength calculated as shown below.

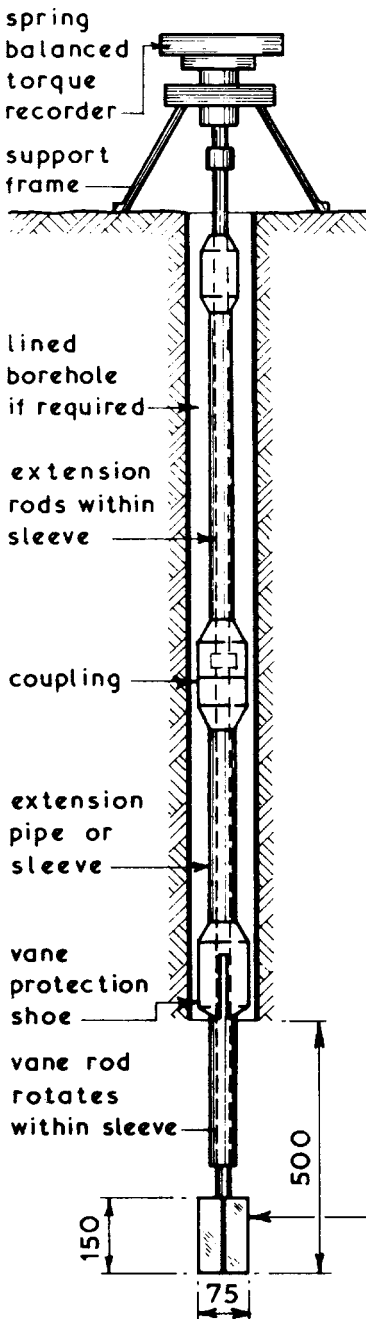

TYPICAL VANE TEST APPARATUS

This test can be carried out within a lined borehole where the vane is pushed into the soil below the base of the borehole for a distance equal to three times the vane diameter before rotation commences. Alternatively the vane can be driven or jacked to the required depth, the vane being protected within a special protection shoe. The vane is then driven or jacked a further 500mm before rotation commences.

Calculation of Shear Strength -

$$\text{Formula: } S = \frac{M}{K}$$

where  $S$  = shear value in  $\text{kN/m}^2$

$M$  = torque required to shear soil

$K$  = constant for vane

$$= 3.66 D^3 \times 10^{-6}$$

$D$  = vane diameter

## Soil Assessment and Testing

Unconfined Compression Test ~ this test can be used to establish the shear strength of a non-fissured cohesive soil sample using portable apparatus either on site or in a laboratory. The 75mm long  $\times$  38mm diameter soil sample is placed in the apparatus and loaded in compression until failure occurs by shearing or lateral bulging. For accurate reading of the trace on the recording chart a transparent viewfoil is placed over the trace on the chart.

Typical Apparatus Details~

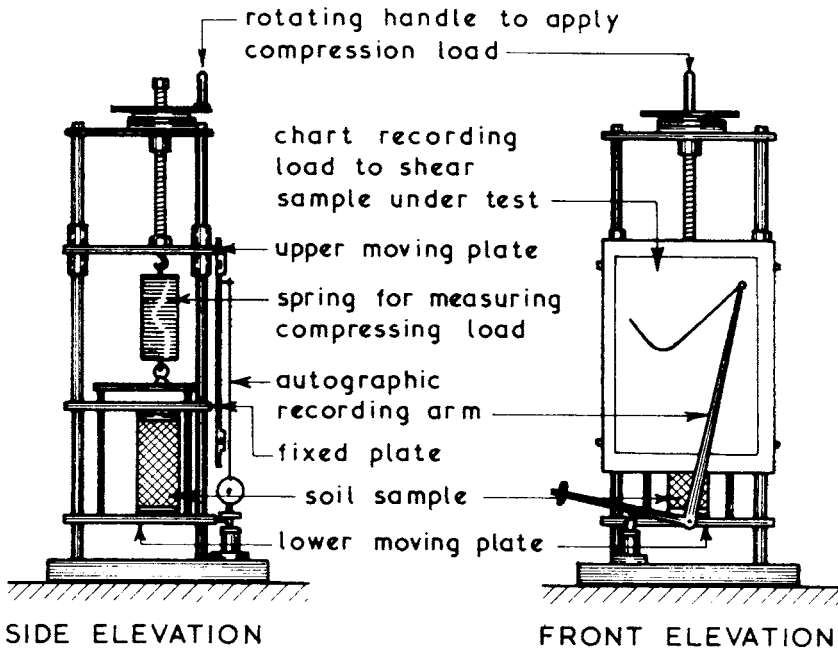

Typical Results ~ showing compression strengths of clays:

Very soft clay	- less than 25kN/m <sup>2</sup>
Soft clay	- 25 to 50kN/m <sup>2</sup>
Medium clay	- 50 to 100kN/m <sup>2</sup>
Stiff clay	- 100 to 200kN/m <sup>2</sup>
Very stiff clay	- 200 to 400kN/m <sup>2</sup>
Hard clay	- more than 400kN/m <sup>2</sup>

NB. The shear strength of clay soils is only half of the compression strength values given above.

Laboratory Testing ~ tests for identifying and classifying soils with regard to moisture content, liquid limit, plastic limit, particle size distribution and bulk density are given in BS 1377.

Bulk Density ~ this is the mass per unit volume which includes mass of air or water in the voids and is essential information required for the design of retaining structures where the weight of the retained earth is an important factor.

Shear Strength ~ this soil property can be used to establish its bearing capacity and also the pressure being exerted on the supports in an excavation. The most popular method to establish the shear strength of cohesive soils is the Triaxial Compression Test. In principle this test consists of subjecting a cylindrical sample of undisturbed soil (75mm long × 38mm diameter) to a lateral hydraulic pressure in addition to a vertical load. Three tests are carried out on three samples (all cut from the same large sample), each being subjected to a higher hydraulic pressure before axial loading is applied. The results are plotted in the form of Mohr's circles.

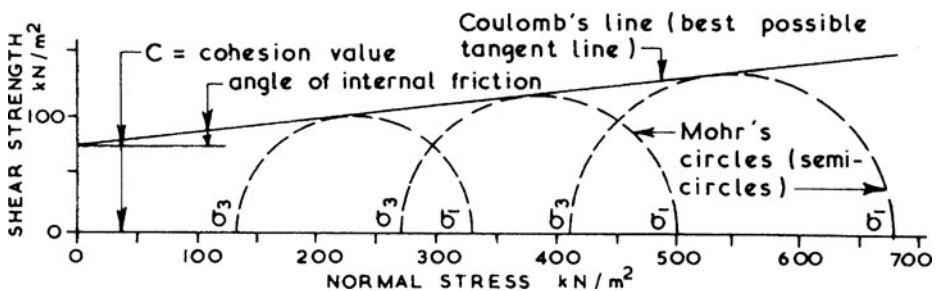
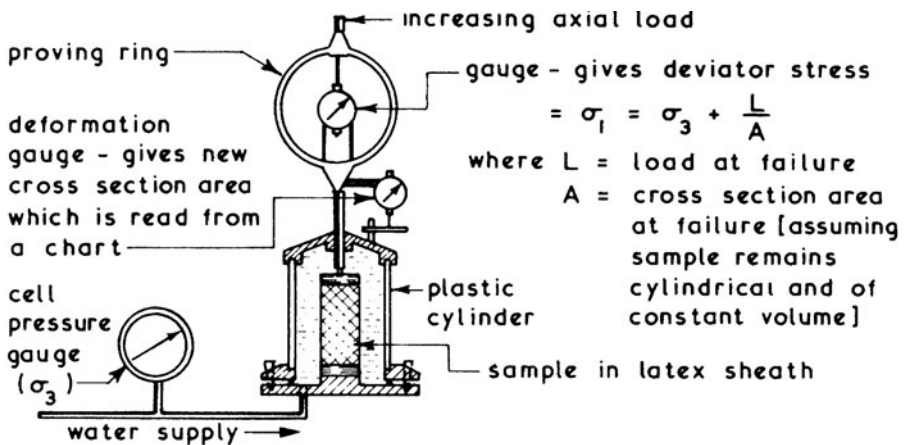



# Soil Assessment and Testing

Shear Strength ~ this can be defined as the resistance offered by a soil to the sliding of one particle over another. A simple method of establishing this property is the Shear Box Test in which the apparatus consists of two bottomless boxes which are filled with the soil sample to be tested. A horizontal shearing force ( $S$ ) is applied against a vertical load ( $W$ ), causing the soil sample to shear along a line between the two boxes.

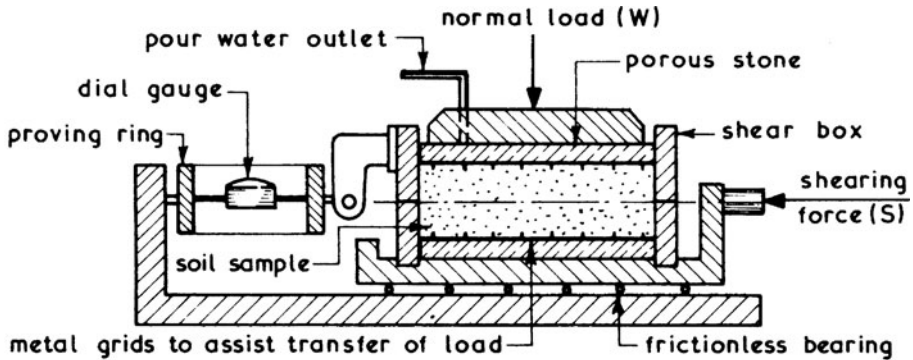

Typical Results ~

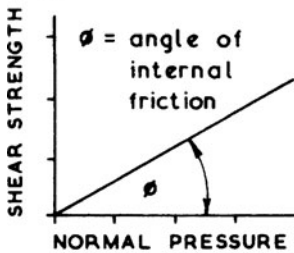

Granular Soils - as load increases, friction between particles increases; therefore shear strength is increased.

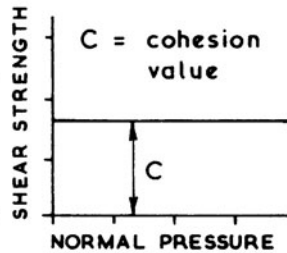

Cohesive Soils - the very small particles develop no friction; therefore shear strength remains constant.

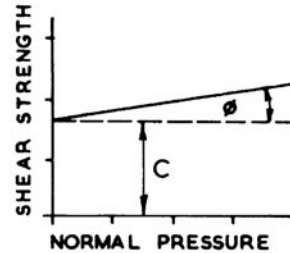

Mixture of Soils - small angle of internal friction is developed as load increases.

Consolidation of Soil ~ this property is very important in calculating the movement of a soil under a foundation. The laboratory testing apparatus is called an Oedometer.

75 mm dia. x 18mm thick soil sample placed in a metal ring and capped with porous discs, then placed in water-filled tray and subjected to load

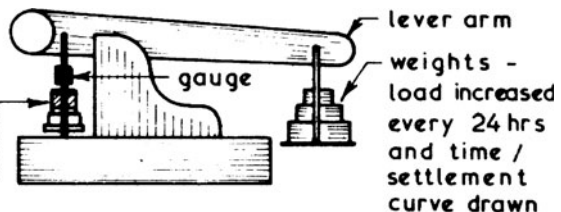

Shrinkable Soils ~ soils subject to volume changes due to variation in moisture content. Pages 245 to 248 show the causes and effects of soil swelling and shrinkage.

Shrinkable Soil Classification ~

- > 35% fine particles.
- Plasticity index (PI)  $\geq 10\%$ .

Fine Particles ~ minute portions of clay (loam) or silt having a nominal diameter of  $< 60 \mu\text{m}$  (0.06mm).

Plasticity Index (PI) ~ a numerical measure of the potential for a soil to change in volume. Can be determined by the Atterberg\* limits test on fine particles  $< 425 \mu\text{m}$  (0.425mm). Particles greater than this are removed by sieving.

$$PI = \text{Liquid limit (LL)} - \text{Plastic limit (PL)}$$

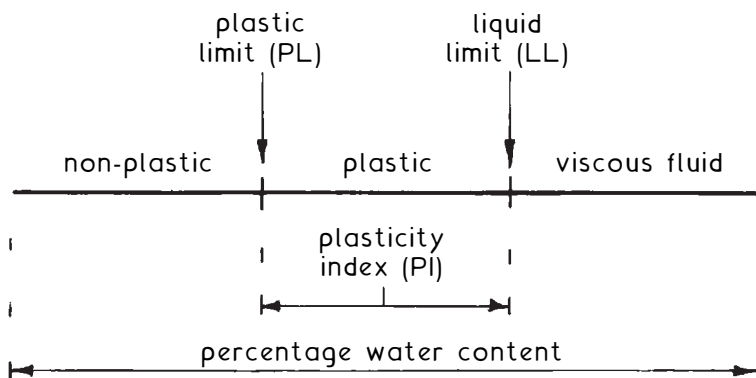

Note: See next page for PL and LL

Soils with a high PI tend to be mainly composed of clay, those with a low PI, of silt.

Plasticity index (PI)	Characteristic plastic quality
0	None
1 - 5	Slight
5 - 10	Low
10 - 20	Medium
20 - 40	High
> 40	Very high

\*Albert Atterberg (1846 - 1916) Swedish chemist.

## Soil Assessment and Testing

Modified Plasticity Index (MPI) ~ a variation of the plasticity index as shown by formula:

$$\text{MPI} = \text{PI} \times \% \text{ of soil particles} < 425 \mu\text{m} \div 100$$

<u>MPI (%)</u>	<u>Soil volume change potential</u>
≥ 40	High
20 - 40	Medium
10 - 20	Low

Atterberg Limits Test ~ (liquid limit and plastic limit) for fine grained soil. As shown on the previous page, determines the state of a soil in terms of non-plastic, plastic and viscous fluid.

Plastic Limit ~ a simple test established by hand rolling a sample of soil on a flat non-porous surface. Soil is defined as plastic when the sample retains its shape down to a very small diameter. The plastic limit occurs when the slender thread of soil breaks apart at a diameter of about 3mm. Considered non-plastic if the thread of soil cannot be rolled down to 3mm at any moisture content. A measure of the relatively low water content at which a soil changes from a plastic state to a solid state.

Liquid Limit ~ water or moisture content when a soil sample changes from plastic to liquid behavioural characteristics. Can also be regarded as the relatively high water content at which soil changes from a liquid to a plastic state.

Atterberg's Original Test Procedure ~ pat of clay soil placed in a porcelain bowl and a groove cut through the middle of the sample. By hand striking the bowl several times the relative characteristics of different clay soils could be measured by the number of blows required to close the groove. This arbitrary test process was later standardised following experimental research attributed to Arthur Casagrande. His procedure quantified and defined results for liquid limit, as outlined on the next page.

Casagrande's Modified Test ~ a refinement of Atterberg's test using a metal bowl of about 100 mm diameter known as a Casagrande\* cup. Into this the soil sample is placed and a 13 mm standard groove cut through the middle. By rotating a cam, the cup drops 10 mm onto a rubber base. Liquid limit is determined by measuring the moisture content (MC) of samples when the groove closes at 25 drops of the cup.

$$MC = \frac{\text{Mass of moist sample} - \text{Mass of dried sample}}{\text{Mass of dried sample}} \times \frac{100}{1}$$

Eg. A soil sample of wet mass 200 grams having an oven dried mass of 168 grams.

$$MC = \frac{200 - 168}{168} \times \frac{100}{1} = 19\%$$

Casagrande Cup Test Apparatus ~

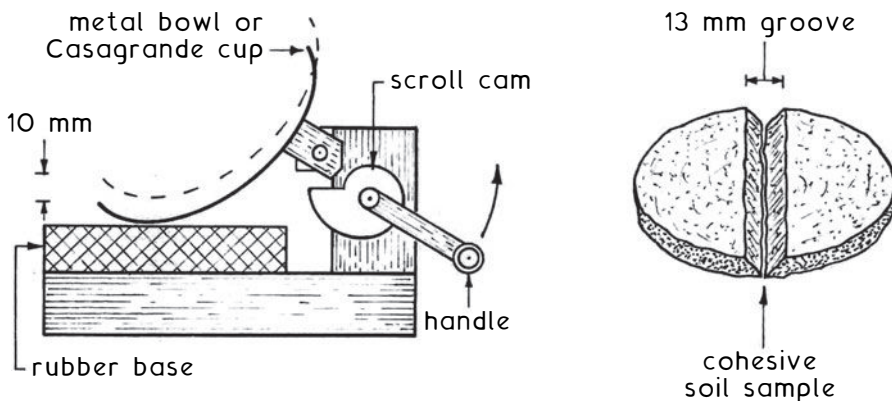

\*Arthur Casagrande (1902 - 1981) Australian born American geophysicist. Also associated with development of the oedometer, shear box and triaxial shear compression tests.

## Site Layout Considerations

General Considerations ~ before any specific considerations and decisions can be made regarding site layout a general appreciation should be obtained by conducting a thorough site investigation at the pre-tender stage and examining in detail the drawings, specification and Bill of Quantities to formulate proposals of how the contract will be carried out if the tender is successful. This will involve a preliminary assessment of plant, materials and manpower requirements plotted against the proposed time scale in the form of a bar chart (see page 37).

Access Considerations ~ this must be considered for both on- and off-site access. Routes to and from the site must be checked as to the suitability for transporting all the requirements for the proposed works. Access on site for deliveries and general circulation must also be carefully considered.

Typical Site Access Considerations ~

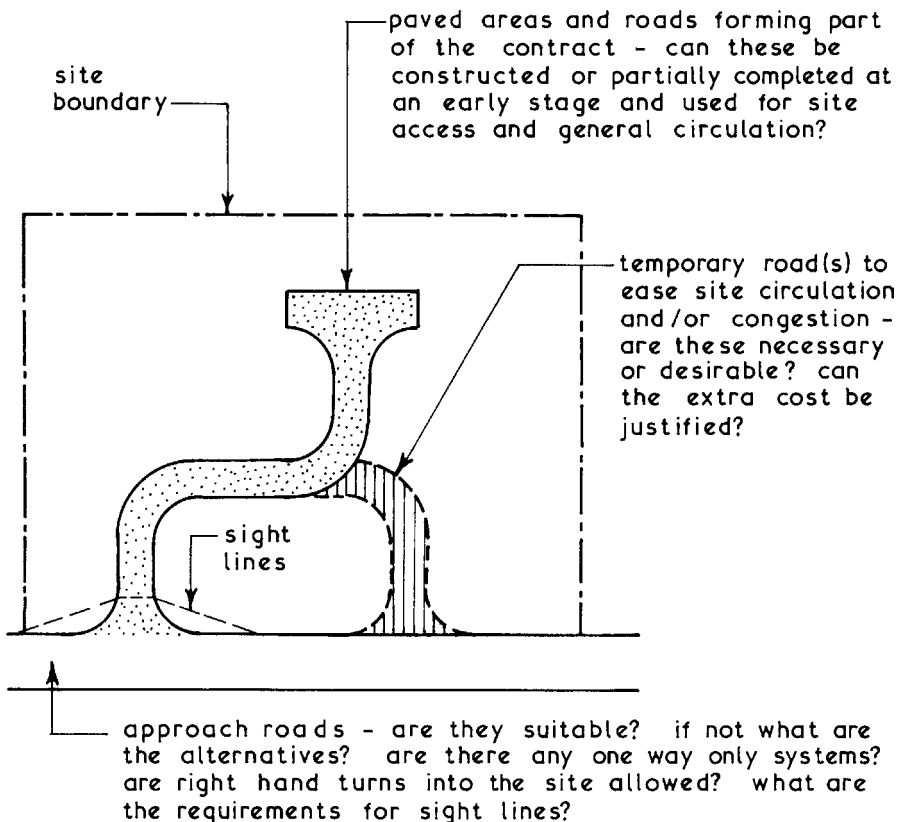

Storage Considerations ~ amount and types of material to be stored. Security and weather protection requirements. Allocation of adequate areas for storing materials and allocating adequate working space around storage areas. Siting of storage areas to reduce double handling to a minimum without impeding the general site circulation and/or works in progress.

Accommodation Considerations ~ number and type of site staff anticipated. Calculate size and select units of accommodation and check to ensure compliance with the minimum welfare requirements of the Construction (Design and Management) Regulations. Select siting for offices to give easy and quick access for visitors but at the same time giving a reasonable view of the site. Select siting for mess room and toilets to reduce walking time to a minimum without impeding the general site circulation and/or works in progress.

Temporary Services Considerations ~ what, when and where are they required? Possibility of having permanent services installed at an early stage and making temporary connections for site use during the construction period. Coordination with the various service undertakings is essential.

Plant Considerations ~ what plant, when and where is it required? Static or mobile plant? If static select the most appropriate position and provide any necessary hardstanding. If mobile check on circulation routes for optimum efficiency and suitability. Provision of space and hardstanding for on-site plant maintenance if required.

Fencing and Hoarding Considerations ~ what is mandatory and what is desirable? Local vandalism record, type or types of fence and/or hoarding required, possibility of using fencing which is part of the contract by erecting this at an early stage in the contract.

Safety and Health Considerations ~ check to ensure that outcome of the above considerations comply with the minimum requirements set out in the various Construction Regulations and in the Health and Safety at Work, etc. Act 1974.

NB. For a typical site layout example see next page.

# Site Layout Considerations

Typical Site Layout Example ~

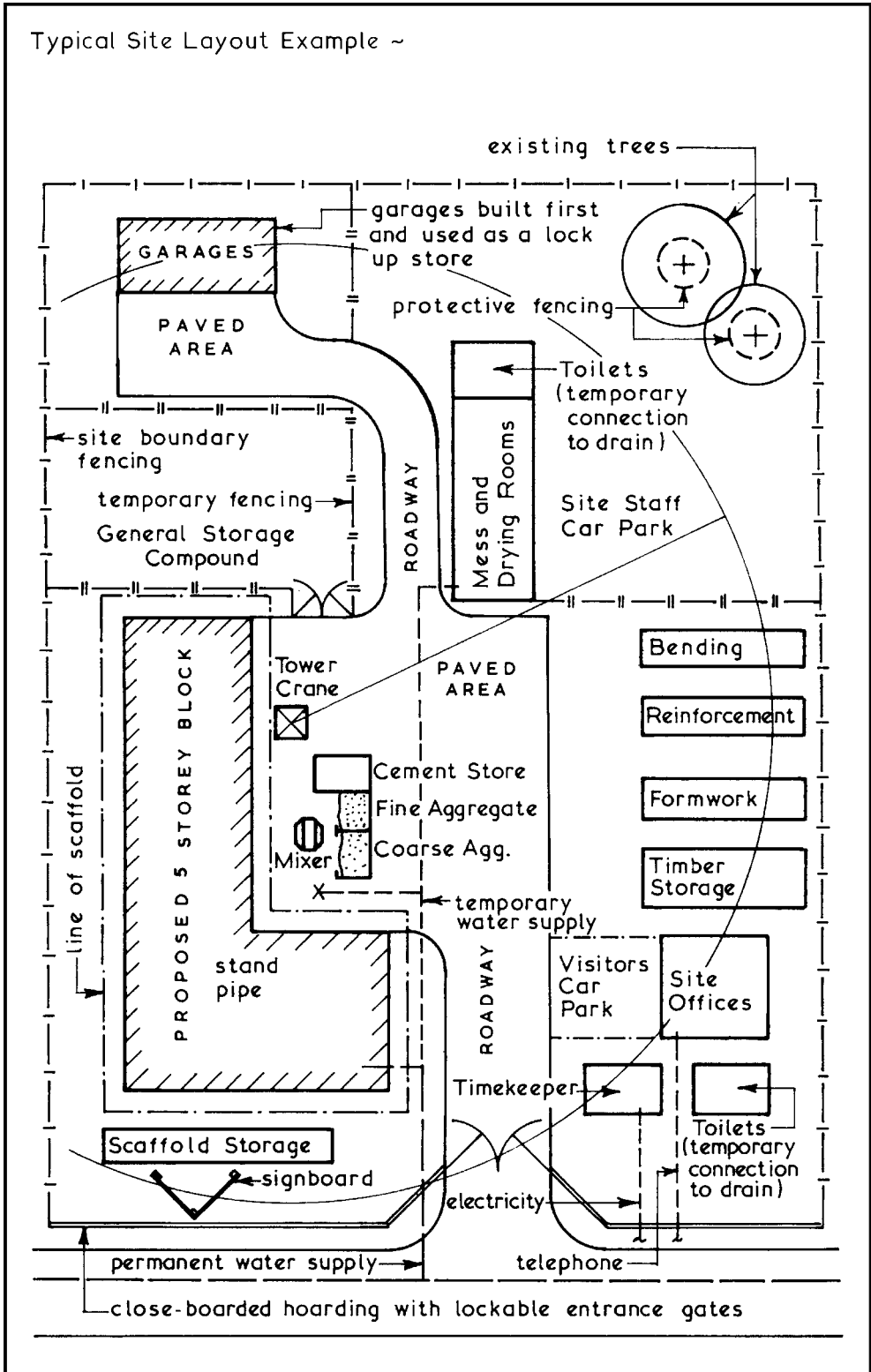

Site Security ~ the primary objectives of site security are:

1. Security against theft.
2. Security from vandals.
3. Protection from innocent trespassers.

The need for and type of security required will vary from site to site according to the neighbourhood, local vandalism record and the value of goods stored on site. Perimeter fencing, internal site protection and night security may all be necessary.

Typical Site Security Provisions ~

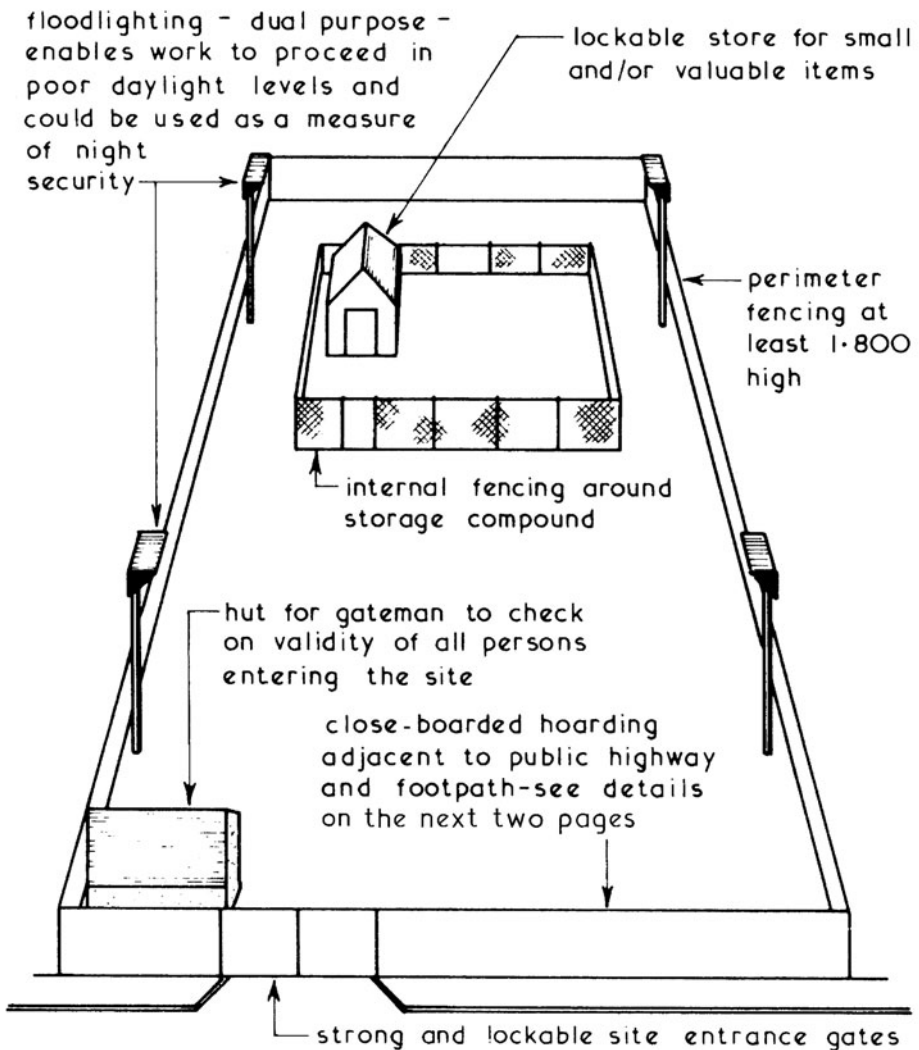



# Hoardings

Hoardings ~ under the Highways Act 1980 a close-boarded fence hoarding must be erected prior to the commencement of building operations if such operations are adjacent to a public footpath or highway. The hoarding needs to be adequately constructed to provide protection for the public, resist impact damage, resist anticipated wind pressures and adequately lit at night. Before a hoarding can be erected a licence or permit must be obtained from the local authority who will usually require 10 to 20 days' notice. The licence will set out the minimum local authority requirements for hoardings and define the time limit period of the licence.

Typical Hoarding Details ~

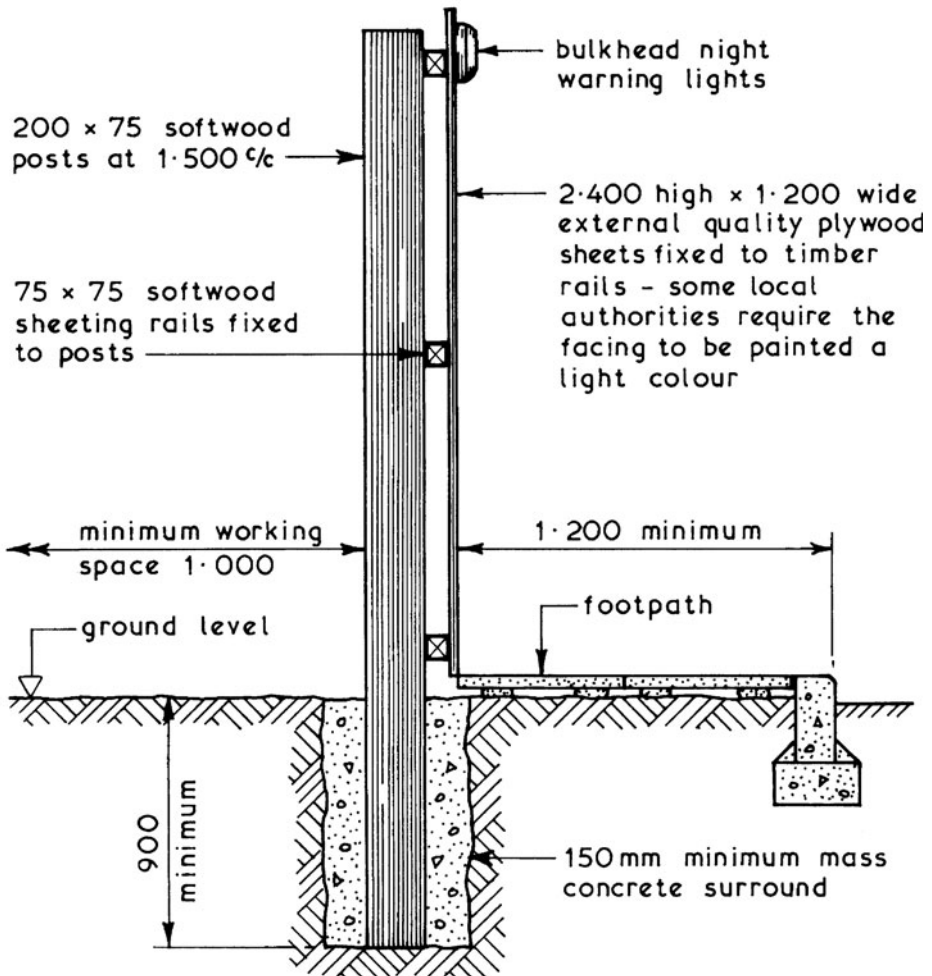

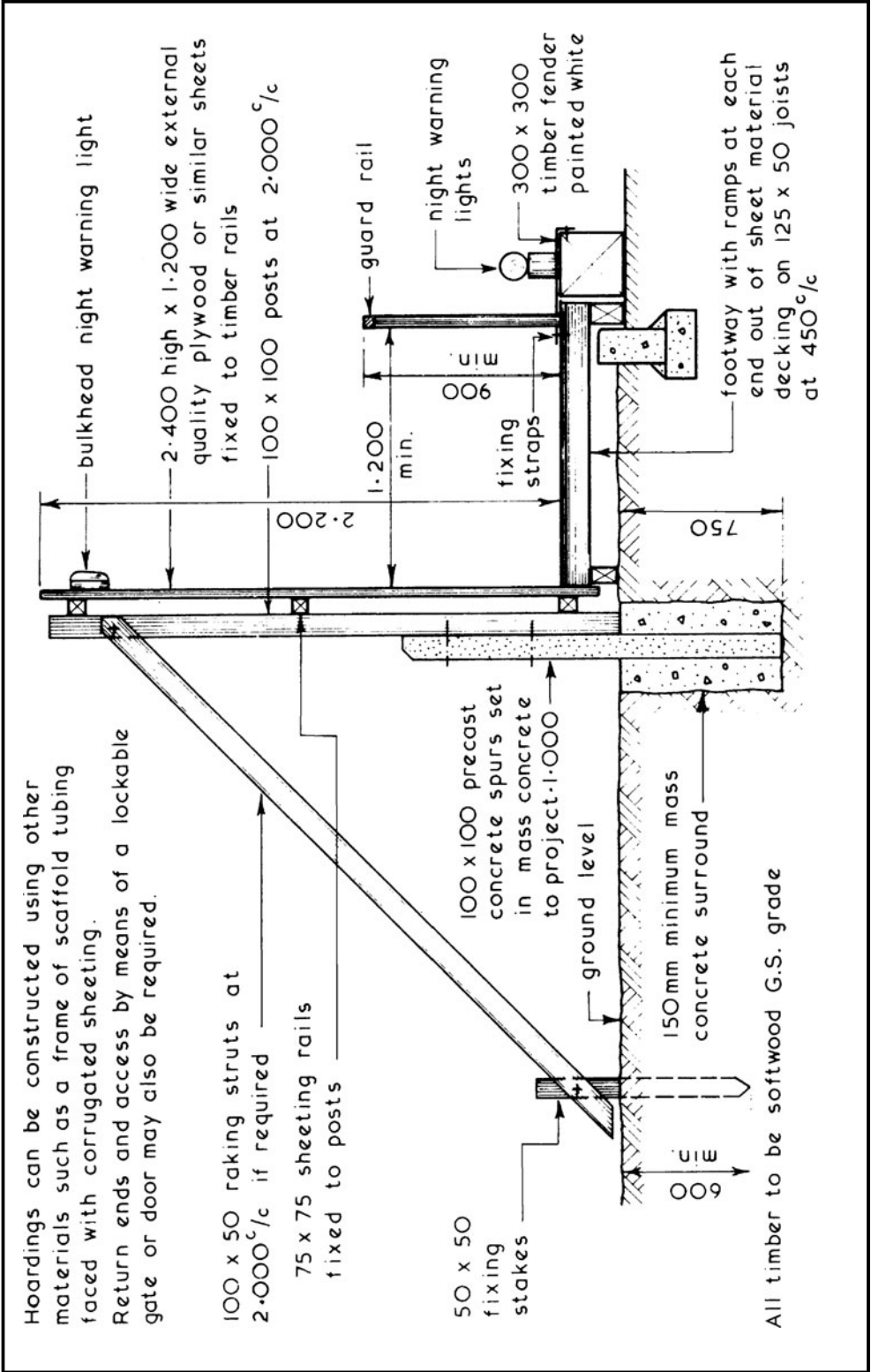

## Site Lighting

Site Lighting ~ this can be used effectively to enable work to continue during periods of inadequate daylight. It can also be used as a deterrent to would-be trespassers. Site lighting can be employed externally to illuminate the storage and circulation areas and internally for general movement and for specific work tasks. The types of lamp available range from simple tungsten filament lamps to tungsten halogen and discharge lamps. The arrangement of site lighting can be static where the lamps are fixed to support poles or mounted on items of fixed plant such as scaffolding and tower cranes. Alternatively the lamps can be sited locally where the work is in progress by being mounted on a movable support or handheld with a trailing lead. Whenever the position of site lighting is such that it can be manhandled it should be run on a reduced voltage of 110V single phase as opposed to the mains voltage of 230V.

To plan an adequate system of site lighting the types of activity must be defined and given an illumination target value which is quoted in lux (lx). Recommended minimum target values for building activities are:

External lighting	- general circulation } materials handling }	10lx
Internal lighting	- general circulation	5lx
	general working areas	15lx
	concreting activities	50lx
	carpentry and joinery } bricklaying }	100lx
	plastering	
	painting and decorating } site offices }	200lx
	drawing board positions	

Such target values do not take into account deterioration, dirt or abnormal conditions; therefore it is usual to plan for at least twice the recommended target values. Generally the manufacturers will provide guidance as to the best arrangement to use in any particular situation but lamp requirements can be calculated thus:

$$\text{Total lumens required} = \frac{\text{area to be illuminated (m}^2\text{)} \times \text{target value (lx)}}{\text{utilisation factor 0.23 [dispersive lights 0.27]}}$$

After choosing lamp type to be used:

$$\text{Number of lamps required} = \frac{\text{total lumens required}}{\text{lumen output of chosen lamp}}$$

Typical Site Lighting Arrangement:

Area lighting using high mounted lamps ~

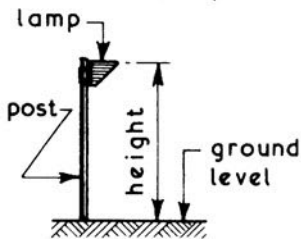
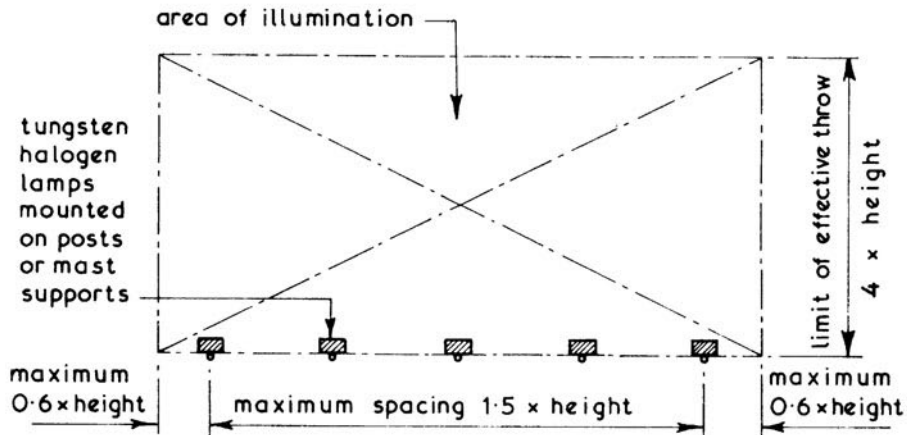

Typical minimum heights for tungsten halogen lamps:

500 watts	-	7.500 metres
1000 watts	-	9.000 metres
2000 watts	-	15.000 metres

Area lighting using overhead dispersive lights suspended from a grid or from the structure ~

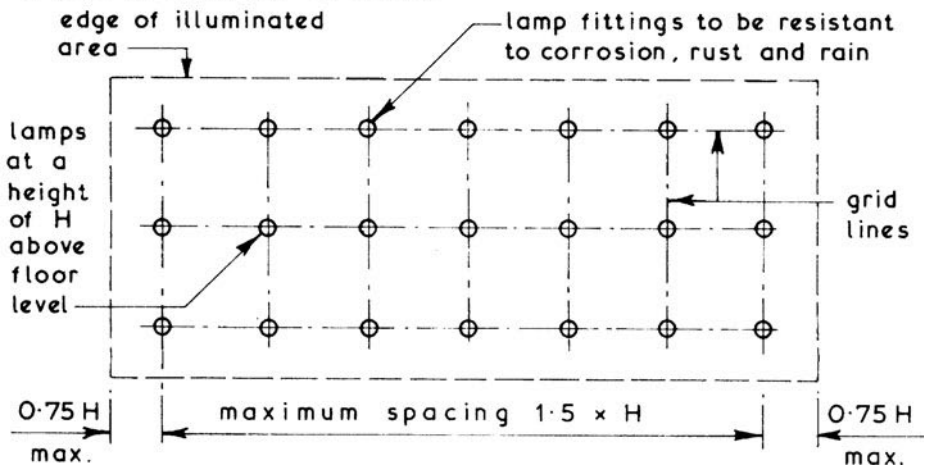

Typical minimum heights for dispersive lamps:

Fluorescent 40 to 125 W - 2.500 m; Tungsten filament 300 W - 3.000 m.

# Site Lighting

Walkway and Local Lighting ~ to illuminate the general circulation routes bulkhead and/or festoon lighting could be used either on a standard mains voltage of 230V or on a reduced voltage of 110V. For local lighting at the place of work hand lamps with trailing leads or lamp fittings on stands can be used and positioned to give the maximum amount of illumination without unacceptable shadow cast.

## Typical Walkway and Local Lighting Fittings ~

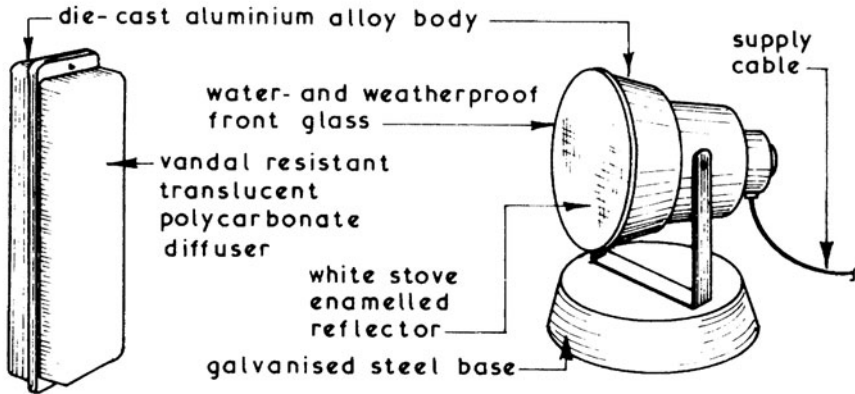

**BULKHEAD LAMP**  
(300mm x 8 W fluorescent)

**LAMP AND STAND**  
(110V tungsten filament)

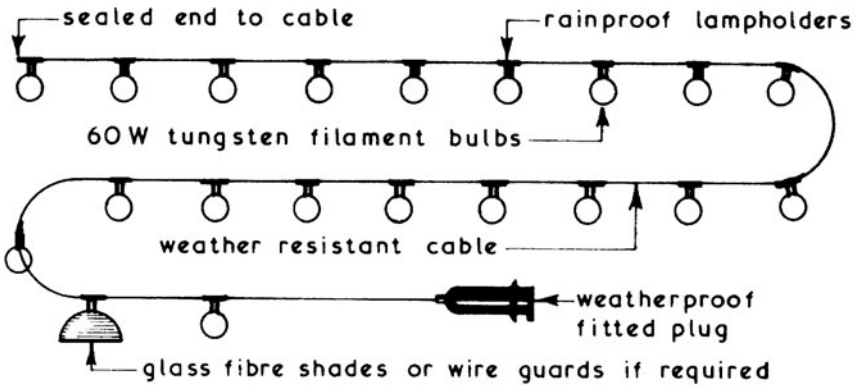

## FESTOON LIGHTING

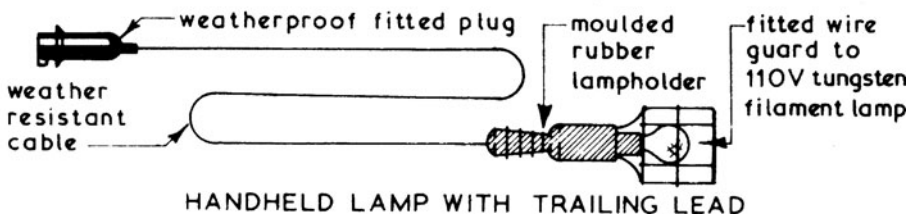

**HANDHELD LAMP WITH TRAILING LEAD**

Electrical Supply to Building Sites ~ a supply of electricity is usually required at an early stage in the contract to provide light and power to the units of accommodation. As the work progresses power could also be required for site lighting, handheld power tools and large items of plant. The supply of electricity to a building site is the subject of a contract between the contractor and the local area electricity company who will want to know the date when supply is required; site address together with a block plan of the site; final load demand of proposed building and an estimate of the maximum load demand in kilowatts for the construction period. The latter can be estimated by allowing 10 W/m<sup>2</sup> of the total floor area of the proposed building plus an allowance for high load equipment such as cranes. The installation should be undertaken by a competent electrical contractor to ensure that it complies with all the statutory rules and regulations for the supply of electricity to building sites.

## Typical Supply and Distribution Equipment ~

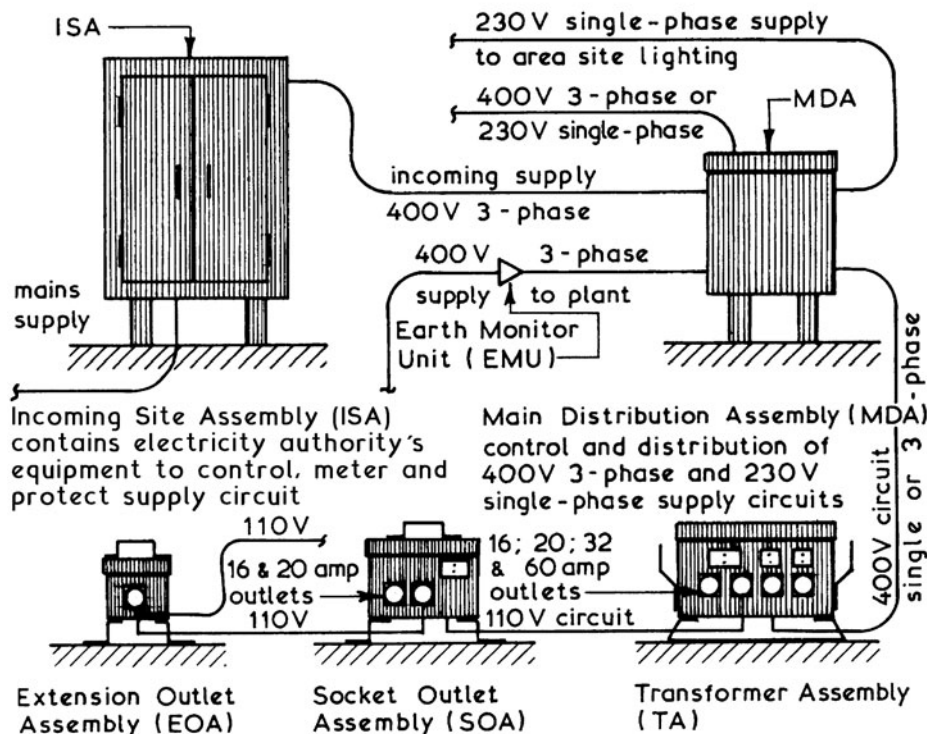

The units must be strong, durable and resistant to rain penetration with adequate weather seals to all access panels and doors. All plug and socket outlets should be colour coded: 400V - red; 230V - blue; 110V - yellow.

## Site Office Accommodation

Office Accommodation ~ the arrangements for office accommodation to be provided on site is a matter of choice for each individual contractor. Generally, separate offices would be provided for site agent, clerk of works, administrative staff, site surveyors and sales staff.

The minimum requirements of such accommodation are governed by the Offices, Shops and Railway Premises Act 1963 unless they are:

1. Mobile units in use for not more than six months.
2. Fixed units in use for not more than six weeks.
3. Any type of unit in use for not more than 21 man hours per week.
4. Office for exclusive use of self-employed person.
5. Office used by family-only staff.

### Sizing Example ~

Office for site agent and assistant plus an allowance for three visitors.

Assume an internal average height of 2.400.

Allow 3.7m<sup>2</sup> minimum per person and 11.5m<sup>3</sup> minimum per person.

Minimum area = 5 × 3.7 = 18.5m<sup>2</sup>

Minimum volume = 5 × 11.5 = 57.5m<sup>3</sup>

Assume office width of 3.000 then minimum length required is

$$= \frac{57.5}{3 \times 2.4} = \frac{57.5}{7.2} = 7.986 \text{ say } 8.000$$

Area check 3 × 8 = 24m<sup>2</sup> which is > 18.5m<sup>2</sup> ∴ satisfactory

### Typical Example ~

Portable cabin with four adjustable steel legs with attachments for stacking. Panelling of galvanised steel sheet and rigid insulation core. Plasterboard inner lining to walls and ceiling. Pyro-shield windows with steel shutters and a high security steel door.

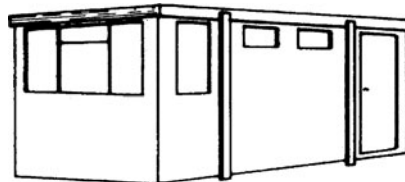

Ref. Fire prevention on construction sites - the joint code of practice on protection from fire of construction sites and buildings undergoing renovation. Published by Construction Industry Publications and The Fire Protection Association.

Applicable where the work is notifiable to the HSE, i.e. work extends to more than 30 days or it involves more than 500 person days.

First aid:

- box readily accessible and distinctly marked.
- contents sufficient for the number of persons on site.
- person appointed with responsibility for first aid facilities and calls to emergency ambulance service (not necessarily a qualified first aider).
- information displayed confirming name of appointed person.
- person trained (first aider) in first aid at work holding an HSE recognised FAW qualification or an emergency first aid at work EFAW qualification.

No. of site personnel	Minimum requirements
< 5	One appointed person preferably trained in first aid
5 - 50	One trained in EFAW or FAW depending on assessment of possible injuries
> 50	One trained in FAW for every 50 persons or part thereof

Sanitary facilities ~

- toilets, separate male and female if possible.
- lockable doors.

Minimum where men and women are employed:

No. of persons on site	No. of WCs	No. of washbasins
≤ 5	1	1
6 - 25	2	2

Thereafter an additional WC and basin for every 25 persons.

Minimum where only men are employed:

No. of men on site	No. of WCs	No. of urinals
1 - 15	1	1
16 - 30	2	1
31 - 45	2	2
46 - 60	3	2
61 - 75	3	3
76 - 90	4	3
91 - 100	4	4

Portable toilets for use where there is no plumbing and drainage, at least one per seven persons, emptied at least once a week.



## Site Health and Welfare Provision (2)

### Washing facilities:

- next to toilets and changing areas.
- hot and cold water or mixed warm water.
- soap, towels or hot air dryer.
- adequate ventilation and lighting.
- washbasins large enough to wash face, hands and forearms.
- showers for particularly dirty work.

### Drinking water:

- wholesome supply direct from the mains.
- bottled water acceptable if mains supply unavailable.
- cups or other drinking vessels at outlets or a drinking fountain.

### Accommodation for rest, shelter, changing and eating:

- separate provisions if men and women are on site.
- located close to washing facilities.
- heated place for shelter from inclement weather.
- space for changing with security for personal clothing, etc.
- lockers and/or place to hang clothes.
- place for wet clothing to be dried.
- rest facilities with tables and raised-back chairs.
- ventilation and lighting.
- means for heating water and warming food unless a separate provision is made for providing meals.

Note: All facilities to be cleaned regularly and serviced with soap, paper, towels, etc.

Refs.: Health and Safety at Work, etc. Act 1974.

Construction (Design and Management) Regulations 2007  
[incorporating the Construction (Health, Safety and Welfare)  
Regulations of 1996].

Health and Safety (First Aid) Regulations 1981.

Workplace (Health, Safety and Welfare) Regulations 1992.

Management of Health and Safety at Work Regulations 1999.

See also requirements and responsibilities for personal protective equipment and clothing summarised on the next page.

Definition ~ 'all equipment (including clothing affording protection against the weather) which is intended to be worn or held by a person at work which protects them against one or more risks to their health and safety.' Personal Protective Equipment Regulations.

Provision ~ by an employer at no cost to employees. Self-employed to provide their own, unless in an employer-employee relationship.

Types of PPE generally required ~

Face and eyes:

- disposable face masks.
- respirators/breathing apparatus (special training required).
- air-fed helmets (special training required).
- safety glasses, similar to ordinary glasses, may have side shields.
- shield, one-piece moulded lens worn over other glasses.
- goggles, flexible plastic frame with elastic headband.
- face guard, shield or visor to fully enclose the eyes from dust, etc.

Hearing:

- earmuffs – helmet mounted available.
- earplugs and ear inserts (canal caps).

Legs and feet:

- safety boots/shoes, steel toe cap and slip-resistant sole.
- Wellington boots, steel toe cap and studded soles available.
- anti-static electricity insulated footwear.
- knee pads, gaiters, leggings and spats.

Body:

- high visibility waistcoats.
- overalls, coveralls and boiler suits.
- aprons, chain mail or leather.
- life jackets.
- safety harnesses.
- insulated and waterproof clothing.

Hands:

- gloves, waterproof and/or insulating.
- gauntlets.
- armlets and wristcuffs.

Risk assessment ~

Hazard – any situation that has the potential to harm.

Risk – possibility of damage, injury or loss caused by a hazard.

Responsibility – all persons in and associated with the work place.

## Site Storage

Site Storage ~ materials stored on site prior to being used or fixed may require protection for security reasons or against the adverse effects which can be caused by exposure to the elements.

Small and Valuable Items ~ these should be kept in a secure and lockable store. Similar items should be stored together in a rack or bin system and only issued against an authorised requisition.

Large or Bulk Storage Items ~ for security protection these items can be stored within a lockable fenced compound. The form of fencing chosen may give visual security by being of an open nature but these are generally easier to climb than the close-boarded type of fence which lacks the visual security property.

Typical Storage Compound Fencing ~

Close-boarded fences can be constructed on the same methods used for hoardings - see pages 116 & 117.

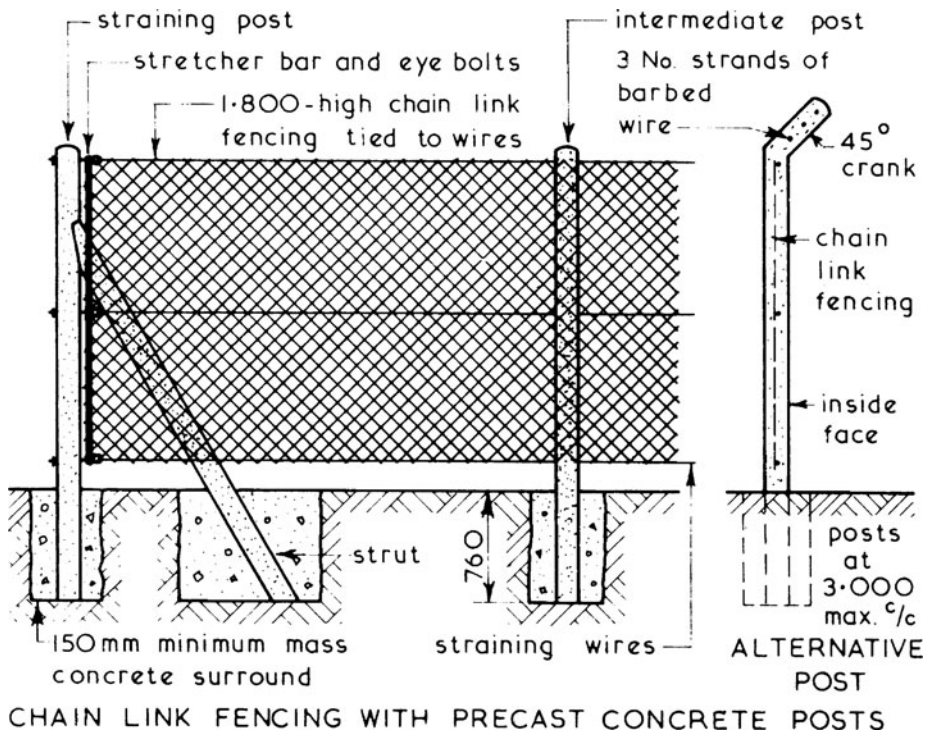

Alternative Fence Types ~ woven wire fence, strained wire fence, cleft chestnut pale fence, wooden palisade fence, wooden post and rail fence and metal fences - see BS 1722: Fences, for details.

Storage of Materials ~ this can be defined as the provision of adequate space, protection and control for building materials and components held on site during the construction process. The actual requirements for specific items should be familiar to students who have completed studies in construction technology at an introductory level but the need for storage and control of materials held on site can be analysed further:

1. Physical Properties - size, shape, weight and mode of delivery will assist in determining the safe handling and stacking method(s) to be employed on site, which in turn will enable handling and storage costs to be estimated.
2. Organisation - this is the planning process of ensuring that all the materials required are delivered to site at the correct time, in sufficient quantity, of the right quality, the means of unloading is available and that adequate space for storage or stacking has been allocated.
3. Protection - building materials and components can be classified as durable or non-durable; the latter will usually require some form of weather protection to prevent deterioration whilst in store.
4. Security - many building materials have a high resale and/or usage value to persons other than those for whom they were ordered and unless site security is adequate material losses can become unacceptable.
5. Costs - to achieve an economic balance of how much expenditure can be allocated to site storage facilities the following should be taken into account:
  - storage areas, fencing, racks, bins, etc.
  - protection requirements.
  - handling, transporting and stacking requirements.
  - salaries and wages of staff involved in storage of materials and components.
  - heating and/or lighting if required.
  - allowance for losses due to wastage, deterioration, vandalism and theft.
  - facilities to be provided for subcontractors.
6. Control - checking quality and quantity of materials at delivery and during storage period, recording delivery and issue of materials and monitoring stock holdings.

## Materials Storage

Site Storage Space ~ the location and size(s) of space to be allocated for any particular material should be planned by calculating the area(s) required and by taking into account all the relevant factors before selecting the most appropriate position on site in terms of handling, storage and convenience. Failure to carry out this simple planning exercise can result in chaos on site or having on site more materials than there is storage space available.

Calculation of Storage Space Requirements ~ each site will present its own problems since a certain amount of site space must be allocated to the units of accommodation, car parking, circulation and working areas, therefore the amount of space available for materials storage may be limited. The size of the materials or component being ordered must be known together with the proposed method of storage and this may vary between different sites of similar building activities. There are therefore no standard solutions for allocating site storage space and each site must be considered separately to suit its own requirements.

Typical Examples ~

Bricks - quantity = 15,200 to be delivered in strapped packs of 380 bricks per pack each being 1100mm wide  $\times$  670mm long  $\times$  850mm high. Unloading and stacking to be by forklift truck to form two rows two packs high.

Area required:- number of packs per row =  $\frac{15,200}{380 \times 2} = 20$

length of row =  $10 \times 670 = 6,700$

width of row =  $2 \times 1100 = 2,200$

allowance for forklift approach in front of stack = 5,000  $\therefore$  minimum brick storage area = 6,700 long  $\times$  7,200 wide

Timber - to be stored in open-sided top covered racks constructed of standard scaffold tubes. Maximum length of timber ordered = 5,600. Allow for rack to accept at least 4 No. 300mm-wide timbers placed side by side then minimum width required =  $4 \times 300 = 1,200$

Minimum plan area for timber storage rack =  $5,600 \times 1,200$

Allow for end loading of rack equal to length of rack

$\therefore$  minimum timber storage area = 11,200 long  $\times$  1,200 wide

Height of rack to be not more than  $3 \times$  width = 3,600

Areas for other materials stored on site can be calculated using the basic principles contained in the examples above.

Site Allocation for Materials Storage ~ the area and type of storage required can be determined as shown on pages 126 to 128, but the allocation of an actual position on site will depend on:

1. Space available after areas for units of accommodation have been allocated.
2. Access facilities on site for delivery, vehicles.
3. Relationship of storage area(s) to activity area(s) - the distance between them needs to be kept as short as possible to reduce transportation needs in terms of time and costs to the minimum. Alternatively storage areas and work areas need to be sited within the reach of any static transport plant such as a tower crane.
4. Security - needs to be considered in the context of site operations, vandalism and theft.
5. Stockholding policy - too little storage could result in delays awaiting materials to be delivered, too much storage can be expensive in terms of weather and security protection requirements apart from the capital used to purchase the materials stored on site.

Typical Example ~

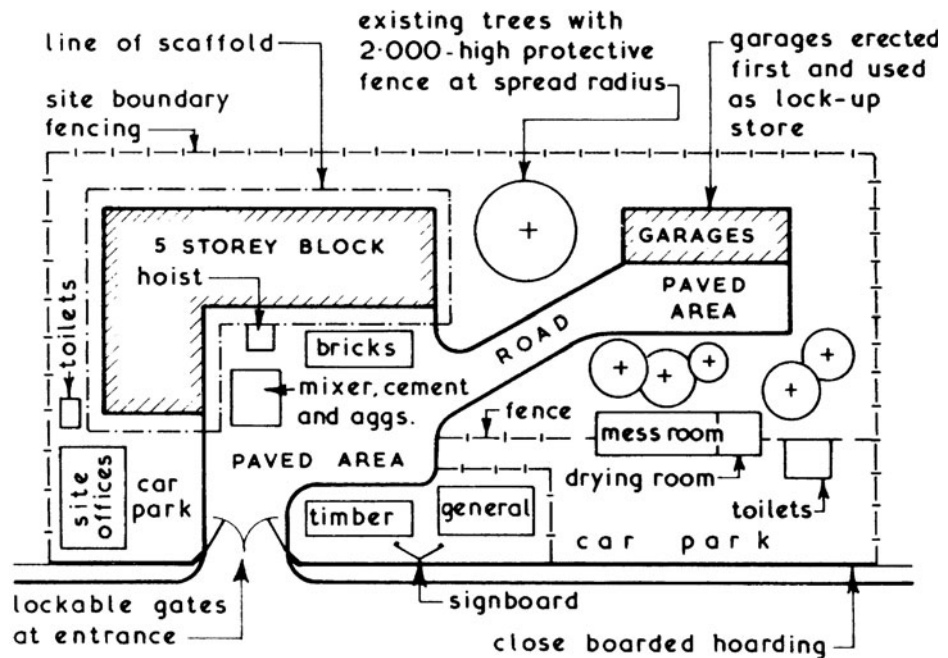

NB. temporary site services omitted for clarity.

# Materials Storage

Bricks ~ may be supplied loose or strapped in unit loads and stored on timber pallets

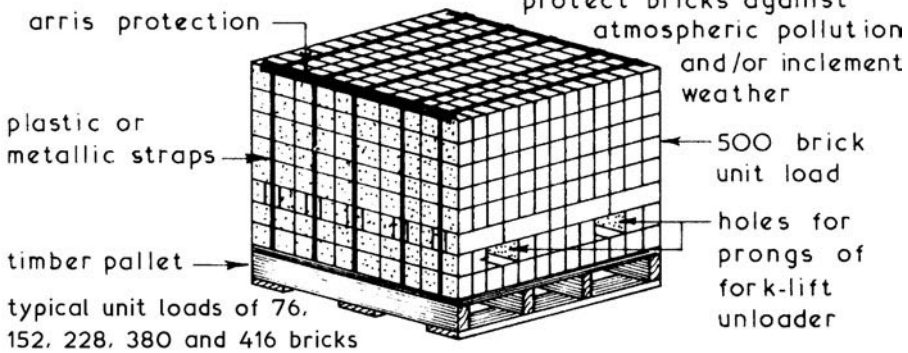
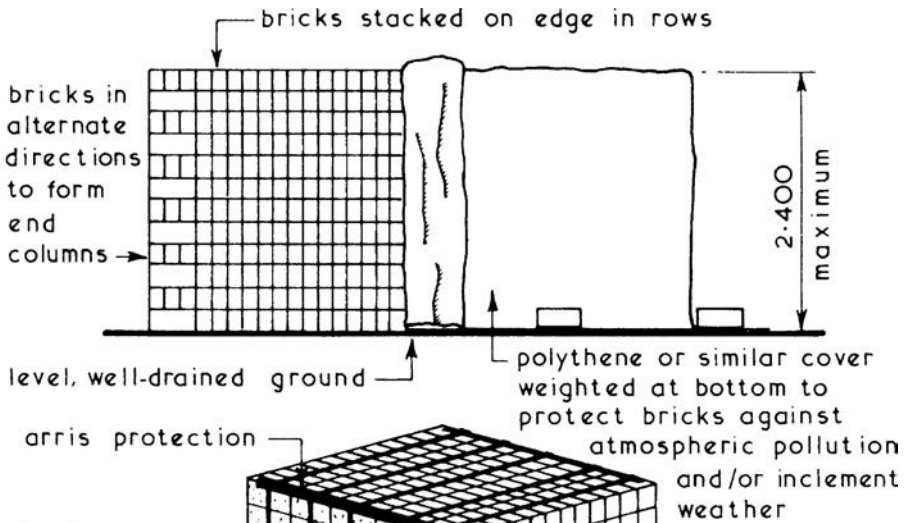

Blocks ~ may be supplied loose or in unit loads on timber pallets

Roofing Tiles ~ may be supplied loose, in plastic-wrapped packs or in unit loads on timber pallets

blocks stacked in 'columns'

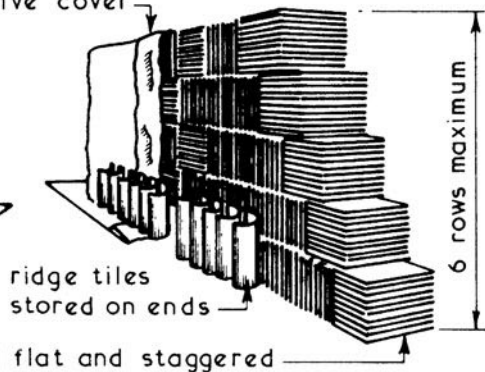
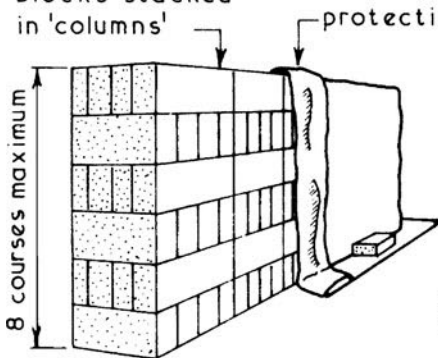

Drainage Pipes ~ supplied loose or strapped together on timber pallets

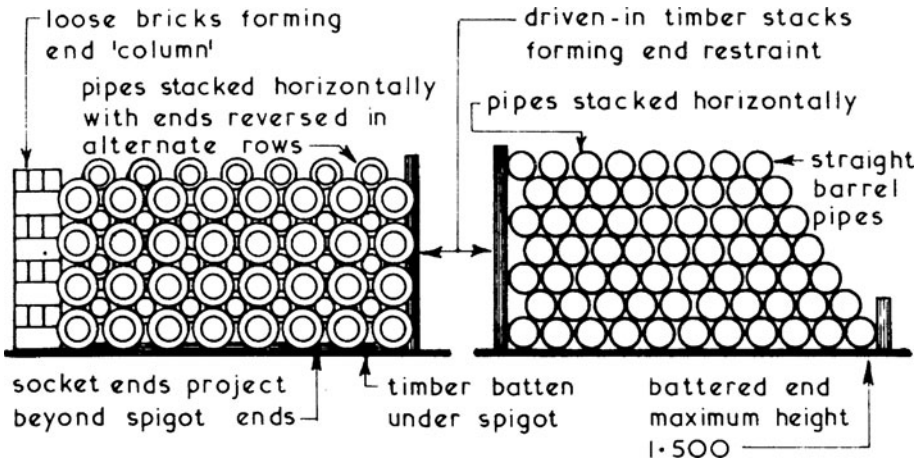

Gullies, etc. should be stored upside down and supported to remain level

Baths ~ stacked or nested vertically or horizontally on timber battens

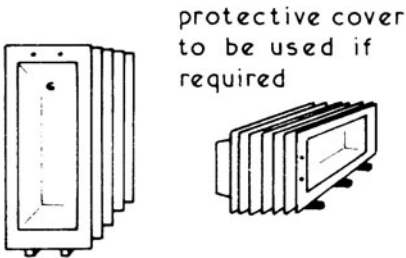

Basins ~ stored similar to baths but not more than four high if nested one on top of another

Corrugated and Similar Sheet Materials ~ stored flat on a level surface and covered with a protective polythene or similar sheet material

Timber and Joinery Items ~ should be stored horizontally and covered but with provision for free air flow

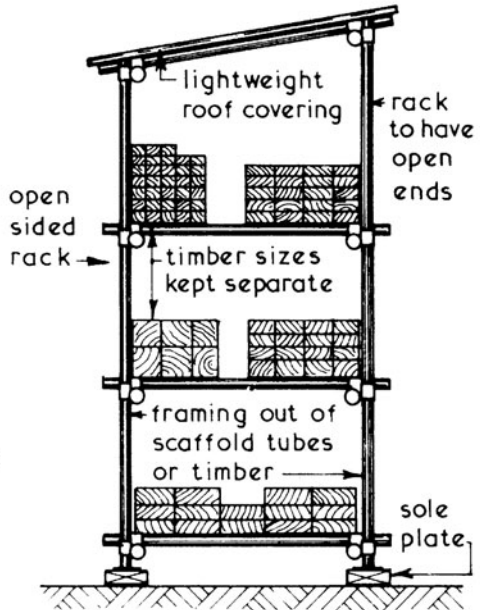

Cement, Sand and Aggregates ~ for supply and storage details see pages 326 and 332.



Site Tests ~ the majority of materials and components arriving on site will conform to the minimum recommendations of the appropriate British Standard and therefore the only tests which need to be applied are those of checking quantity received against amount stated on the delivery note, ensuring quality is as ordered and a visual inspection to reject damaged or broken goods. The latter should be recorded on the delivery note and entered in the site records. Certain site tests can however be carried out on some materials to establish specific data such as the moisture content of timber which can be read direct from a moisture meter. Other simple site tests are given in the various British Standards to ascertain compliance with the recommendations, such as tests for dimensional tolerances and changes given in BS EN 771-1 and BS EN 772-16 which cover random sampling of clay bricks of up to 10 units. An alternative site test can be carried out by measuring a sample of 24 bricks taken at random from a delivered load thus:

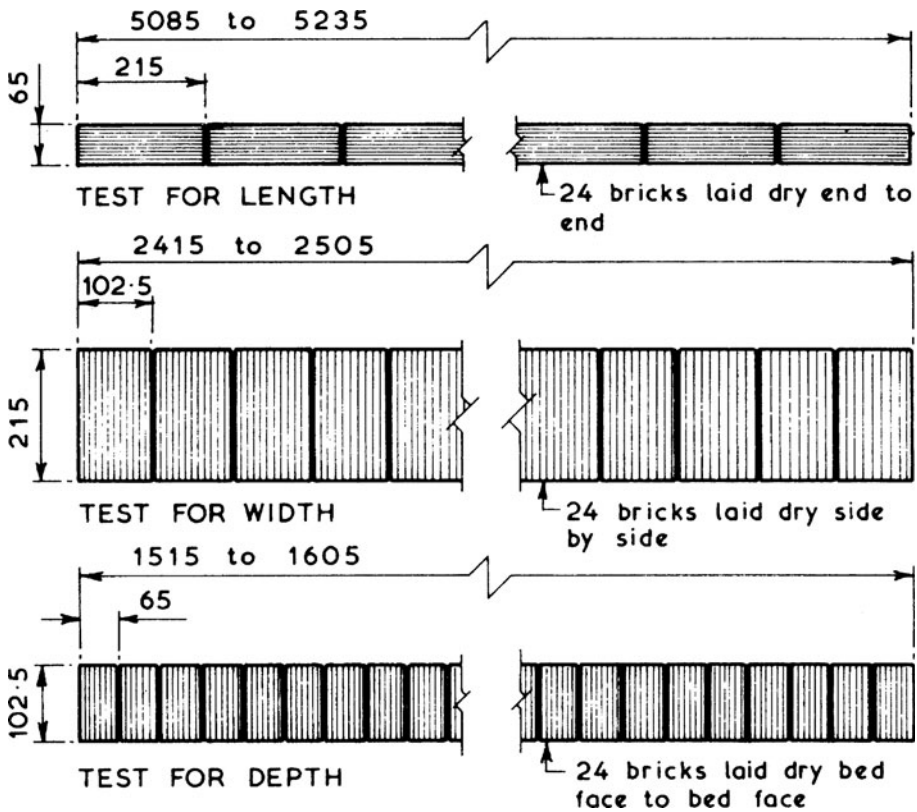

Refs.: BS EN 772-16: Methods of test for masonry units.  
 BS EN 771-1: Specification for masonry units.

Site Test ~ apart from the test outlined on page 132 site tests on materials which are to be combined to form another material such as concrete can also be tested to establish certain properties which if not known could affect the consistency and/or quality of the final material.

Typical Example ~ Testing Sand for Bulking

This data is required when batching concrete by volume - test made at commencement of mixing and if change in weather

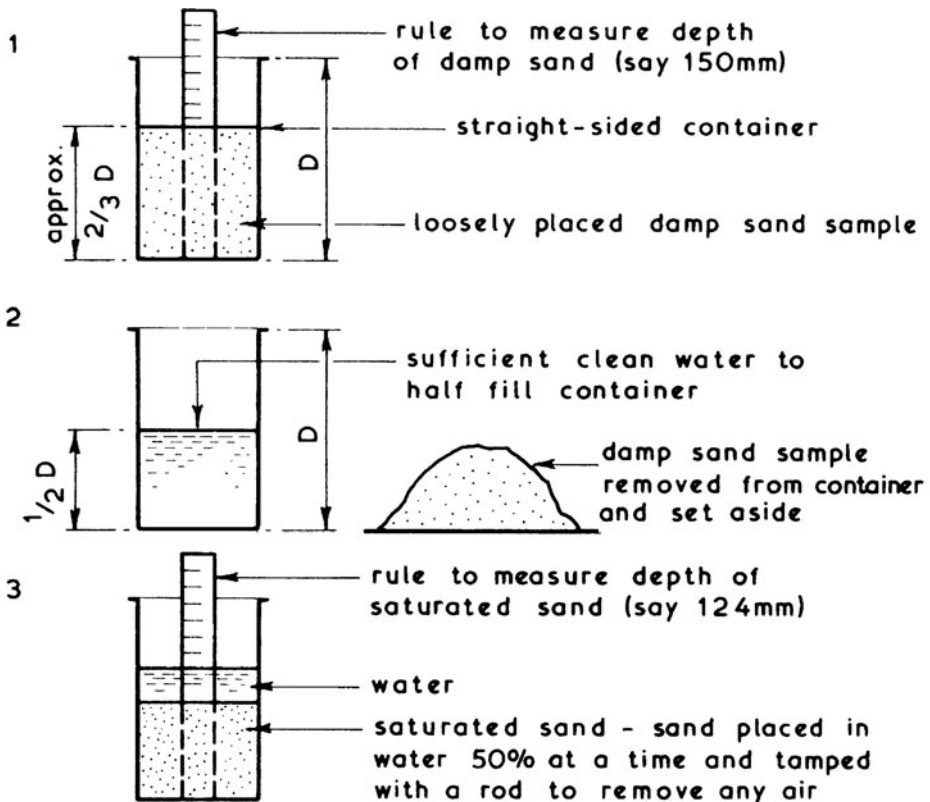

4 Calculation:

$$\text{bulking} = \frac{\text{difference in height between damp and saturated sand}}{\text{depth of saturated sand}}$$



$$\% \text{ bulking} = \frac{150 - 124}{124} \times 100 = \frac{26}{124} \times 100 = 20.96774\%$$

Therefore volume of sand should be increased by 21% over that quoted in the specification.

NB. a given weight of saturated sand will occupy the same space as when dry but more space when damp.

## Materials Testing

Silt Test for Sand ~ the object of this test is to ascertain the cleanliness of sand by establishing the percentage of silt present in a natural sand since too much silt will weaken the concrete

1.  measuring cylinder marked in millilitres  
make up salt water solution of 5 ml salt to 500 ml water  
salt water solution up to 50 ml mark
2.  add sand sample to salt water up to 50 ml mark  
add more salt water solution up to 150 ml mark and shake cylinder well
3.  allow mixture to stand for three hours and measure height of silt  
salt water  
silt  
sand
4. Height of silt layer should not be more than 6 ml or 6% of height of sand sample

Obtaining Samples for Laboratory Testing ~ these tests may be required for checking aggregate grading by means of a sieve test, checking quality or checking for organic impurities, but whatever the reason the sample must be truly representative of the whole:

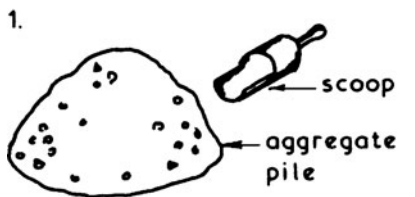

samples extracted by means of a scoop from at least ten different positions in the pile

sample required:

fine aggregate - 50 kg  
coarse aggregate - 200 kg

Ref. BS EN 12620: Aggregates for concrete.

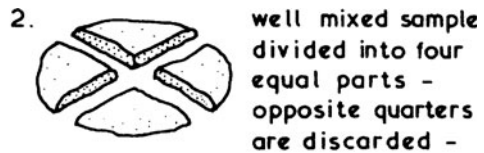

remainder of sample remixed and quartered - whole process is repeated until required size of sample is left.  
samples required:

fine aggregate ➤ 4 mm - 3 kg  
coarse aggregate ➤ 10mm - 6 kg  
➤ 20mm - 25 kg  
➤ 40mm - 50 kg

The quality of site mixed concrete should be monitored, especially to ensure uniformity of mix components and consistency of batches. When constituents are known to be constant by design, the water/cement ratio of consecutive batches can be compared by using a slump test. Water for hydration is about one quarter of the cement weight, but if a w/c ratio of 0.25 were used the mix would be too stiff and unworkable. Therefore, a w/c ratio of 0.5 is more usual; the additional water providing a lubricant for the aggregates and cement. Increasing the w/c ratio above 0.5 will make the concrete easier to work, but it will be detrimental to the final compressive strength (see page 329) unless other measures are incorporated to counter this, e.g. steel or fabric reinforcement.

Slump Test Equipment ~ shown below, an open ended frustum of a cone, tamping rod and a rule. Dimensions in mm.

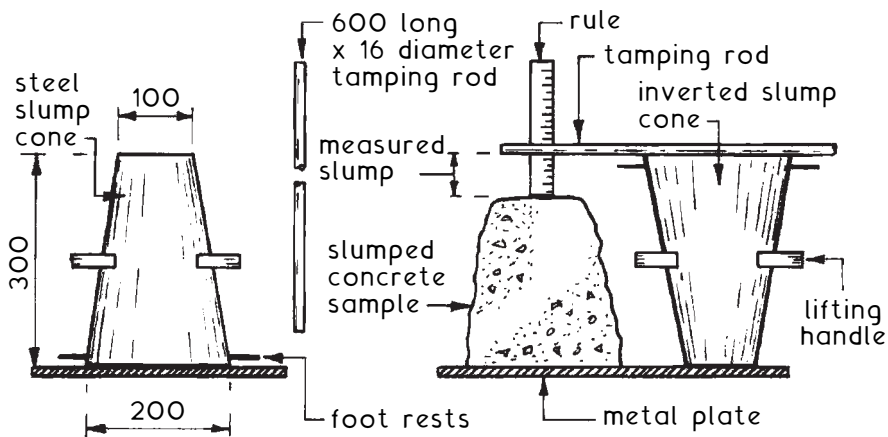

Procedure ~ the cone is one-quarter filled with concrete and tamped 25 times. Further filling and tamping is repeated three more times until the cone is full and the sample levelled off. The cone is removed and the concrete slump measured. The measurement should be consistent for all samples of concrete being used in the same situation.

Typical Slump Specification ~ generally between 50 and 100 mm depending on application. See page 331 for slump consistency classes applicable to standard prescribed site batched concrete mixes.

Ref. BS EN 12350-2: Testing fresh concrete. Slump test.

# Materials Testing

## Procedure for Testing Batched Concrete from Source ~

- Wet concrete samples extracted from the mixer batch are placed into machine faced steel casting moulds in 50mm layers.
- Each layer compacted at least 35 times (150mm cube) or 25 times (100mm cube) with a tamping bar.
- Alternatively, each layer may be consolidated by external vibration from an electric or pneumatic hammer.
- Surplus concrete trowelled off and samples marked with time, date and job reference.
- Samples left for 24 hours  $\pm$  30 minutes and covered with a damp cloth.
- After 24 hours, samples removed from moulds and submersed in water at  $20^{\circ}\text{C} \pm 2^{\circ}\text{C}$ .
- At 7 days, hydraulic compression test applied to sample cubes to determine stress failure strength.
- If strength specification not achieved, other samples from the same batch tested at 28 days.
- If 28 day samples fail compressive strength requirement, core samples may be taken from placed concrete for further laboratory analysis.

## Equipment ~

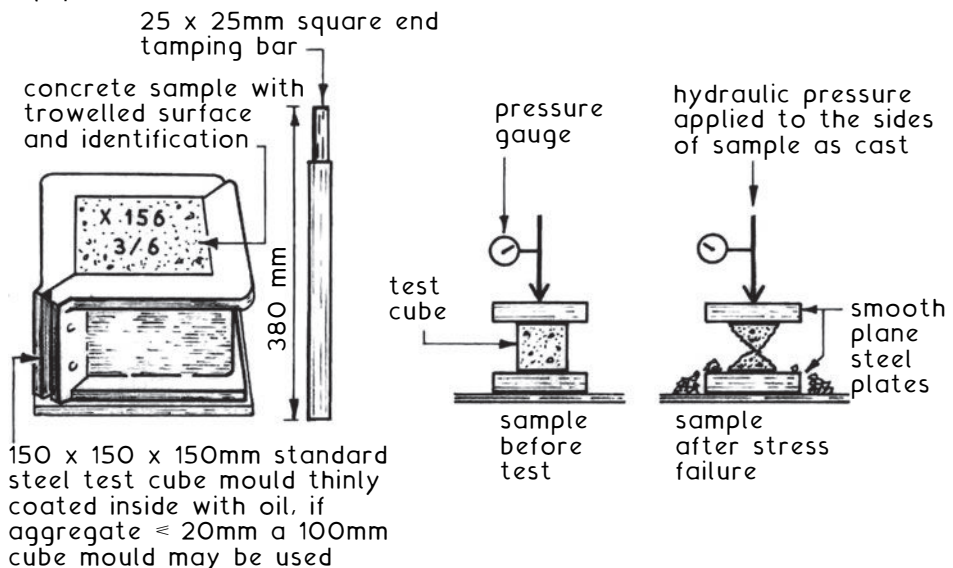

28 day characteristic crushing strength categories below which not more than 5% of test results are permitted to fail, are: 7.5, 10, 15, 20, 25, 30 and  $35\text{N/mm}^2$ . 40, 45 and  $50\text{N/mm}^2$  are also specified, mainly for prestressed reinforced concrete.

Ref. BS EN 12390-1: Testing hardened concrete. Shape, dimensions and other requirements for specimens and moulds.

Non-destructive testing of concrete. Also known as in-place or in-situ tests.

Changes over time and in different exposures can be monitored.

References: BS 6089: Assessment of in-situ compressive strength in structures and precast concrete components.

BS 1881: Testing concrete.

BS EN 13791: Assessment of in-situ compressive strength in structures and precast concrete components.

Provides information on: strength in-situ, voids, flaws, cracks and deterioration.

Rebound hammer test - attributed to Ernst Schmidt after he devised the impact hammer in 1948. It works on the principle of an elastic mass rebounding off a hard surface. Varying surface densities will affect impact and propagation of stress waves. These can be recorded on a numerical scale known as rebound numbers. It has limited application to smooth surfaces of concrete only. False results may occur where there are local variations in the concrete, such as a large piece of aggregate immediately below the impact surface. Rebound numbers can be graphically plotted to correspond with compressive strength.

Ref. BS EN 12504-2: Testing concrete in structures. Non-destructive testing. Determination of rebound number.

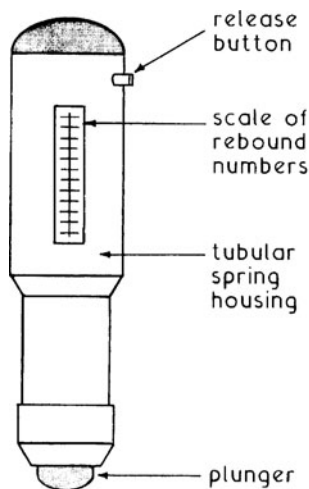

SCHMIDT HAMMER

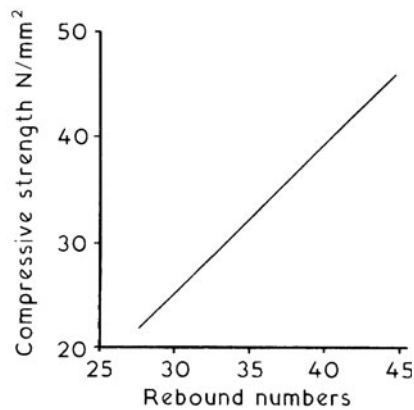

CONVERSION CHART  
(illustration only)

Penetration or Windsor probe test ~ there are various interpretations of this test. It is a measure of the penetration of a steel alloy rod, fired by a predetermined amount of energy into concrete. In principle, the depth of penetration is inversely proportional to the concrete compressive strength. Several recordings are necessary to obtain a fair assessment and some can be discarded particularly where the probe cannot penetrate some dense aggregates. The advantage over the rebound hammer is provision of test results at a greater depth (up to 50mm).

Pull-out test ~ this is not entirely non-destructive as there will be some surface damage, albeit easily repaired. A number of circular bars of steel with enlarged ends are cast into the concrete as work proceeds. This requires careful planning and location of bars with corresponding voids provided in the formwork. At the appropriate time, the bar and a piece of concrete are pulled out by tension jack. Although the concrete fails in tension and shear, the pull-out force can be correlated to the compressive strength of the concrete.

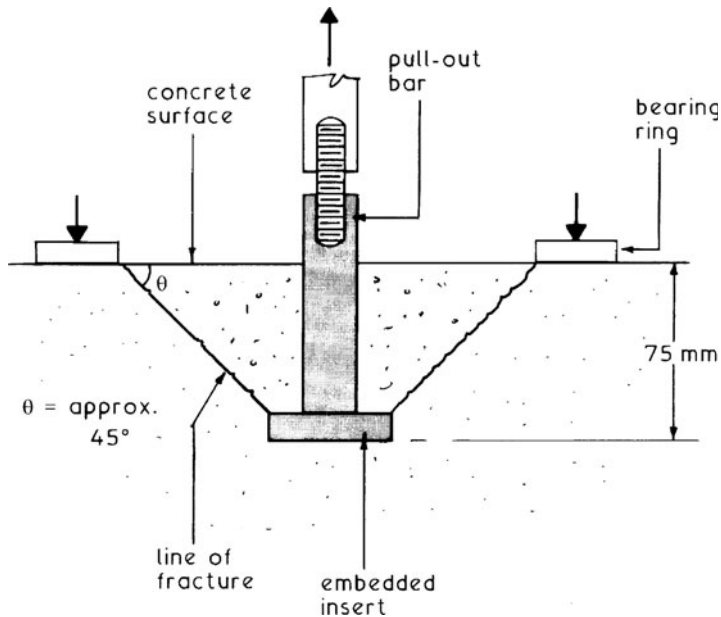

Ref. BS 1881-207: Testing concrete. Recommendations for the assessment of concrete strength by near-to-surface tests.

Vibration test ~ a number of electronic tests have been devised, which include measurement of ultrasonic pulse velocity through concrete. This applies the principle of recording a pulse at predetermined frequencies over a given distance. The apparatus includes transducers in contact with the concrete, pulse generator, amplifier, and time measurement to digital display circuit. For converting the data to concrete compressive strength, see BS EN 12504-4: Testing concrete. Determination of ultrasonic pulse velocity.

A variation, using resonant frequency, measures vibrations produced at one end of a concrete sample against a receiver or pick up at the other. The driving unit or exciter is activated by a variable frequency oscillator to generate vibrations varying in resonance, depending on the concrete quality. The calculation of compressive strength by conversion of amplified vibration data is by formulae found in BS 1881-209: Testing concrete. Recommendations for the measurement of dynamic modulus of elasticity.

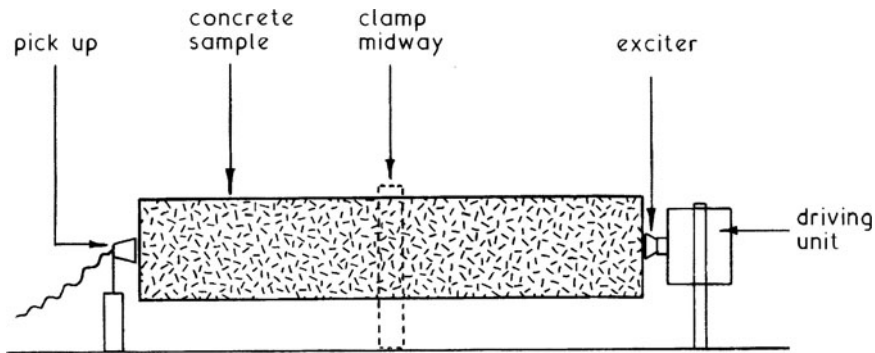

RESONANT FREQUENCY TEST

Other relevant standards:

BS 1881-122: Testing concrete. Method for determination of water absorption.

BS 1881-124: Testing concrete. Methods for analysis of hardened concrete.

BS EN 12390-7: Testing hardened concrete. Density of hardened concrete.



The quality of softwood timber for structural use depends very much on the environment in which it is grown and the species selected. Timber can be visually strength graded, but this is unlikely to occur at the construction site except for a general examination for obvious handling defects and damage during transit. Site inspection will be to determine that the grading authority's markings on the timber comply with that specified for the application.

Format of strength grade markings on softwood timber for structural uses ~

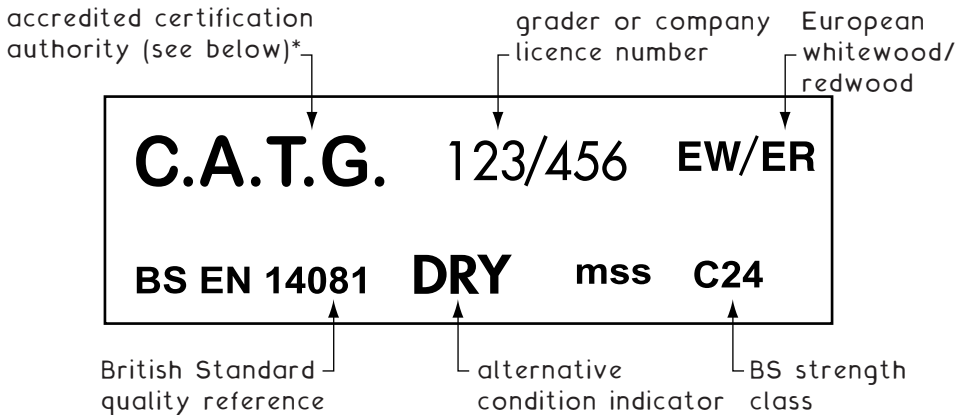
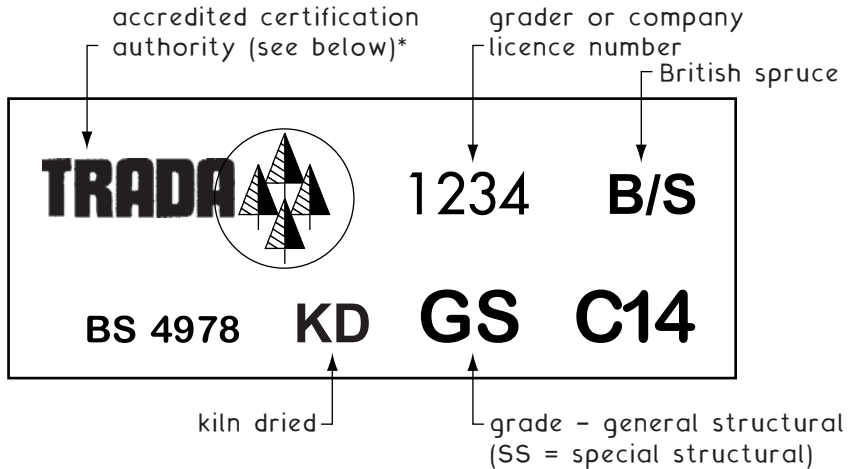

\*Accredited certification authorities include  
 BM TRADA Certification Ltd. and Certification And Timber Grading Ltd.

Refs.: BS 4978: Visual strength grading of softwood. Specification.  
 BS EN 14081: Timber structures. Strength graded structural timber with rectangular cross section (four parts).

Grading ~ either visually or by computerised machine. Individual rectangular timber sections are assessed against permissible defect limitations and grade marked accordingly.

UK grading standard ~ BS 4978.

European grading standard ~ BS EN 14081 (four parts).

The two principal grades apart from rejects are GS (general structural) and SS (special structural) preceded with an M if graded by machine.

Additional specification is to BS EN 338: Structural timber. Strength classes. This standard provides softwood strength classifications from C14 to C40 as well as a separate classification of hardwoods.

A guide to softwood grades with strength classes for timber from the UK, Europe and North America ~

Source/species	Strength class (BS EN 338)						
	C14	C16	C18	C22	C24	C27	C30
UK:							
British pine	GS			SS			
British spruce	GS		SS				
Douglas fir	GS		SS				
Larch	GS				SS		
Ireland:							
Sitka and Norway spruce	GS		SS				
Europe:							
Redwood or white-wood		GS			SS		
USA:							
Western whitewood	GS		SS				
Southern pine		GS			SS		
USA/Canada:							
Spruce/pine/fir or hemlock		GS			SS		
Douglas fir and larch		GS			SS		
Canada:							
Western red cedar	GS		SS				
Sitka spruce	GS		SS				

BS EN 338: Structural softwood classifications and typical strength properties ~

BS EN 338 strength class	Bending parallel to grain (N/mm <sup>2</sup> )	Tension parallel to grain (N/mm <sup>2</sup> )	Compression parallel to grain (N/mm <sup>2</sup> )	Compression perpendicular to grain (N/mm <sup>2</sup> )	Shear parallel to grain (N/mm <sup>2</sup> )	Modulus of elasticity Mean (N/mm <sup>2</sup> )	Characteristic density (kg/m <sup>3</sup> )	Average density (kg/m <sup>3</sup> )
C14	4.1	2.5	5.2	2.1	0.60	6800	290	350
C16	5.3	3.2	6.8	2.2	0.67	8800	310	370
C18	5.8	3.5	7.1	2.2	0.67	9100	320	380
C22	6.8	4.1	7.5	2.3	0.71	9700	340	410
C24	7.5	4.5	7.9	2.4	0.71	10800	350	420
TR26	10.0	6.0	8.2	2.5	1.10	11000	370	450
C27	10.0	6.0	8.2	2.5	1.10	12300	370	450
C30	11.0	6.6	8.6	2.7	1.20	12300	380	460
C35	12.0	7.2	8.7	2.9	1.30	13400	400	480
C40	13.0	7.8	8.7	3.0	1.40	14500	420	500

Notes: 1. Strength class TR26 is specifically for the manufacture of trussed rafters.

2. Characteristic density values are given specifically for the design of joints. Average density is appropriate for calculation of dead load.

3. For a worked example of a softwood timber joist/beam design using data for strength classification C24 (e.g. SS graded European redwood) see pages 777 and 778.

Visual strength grading ~ process by which a piece of timber can be sorted, by means of visual inspection, into a grade to which characteristic values of strength, stiffness and density may be allocated. Definition from BS EN 14081-1.

Characteristics:

Knots ~ branch growth from or through the main section of timber weakening the overall structural strength. Measured by comparing the sum of the projected cross sectional knot area with the cross-sectional area of the piece of timber. This is known as the knot area ratio (KAR). Knots close to the edge of section have greater structural significance; therefore this area is represented as a margin condition at the top and bottom quarter of a section. A margin condition exists when more than half the top or bottom quarter of a section is occupied by knots.

MKAR = Margin knot area ratio.

TKAR = Total knot area ratio.

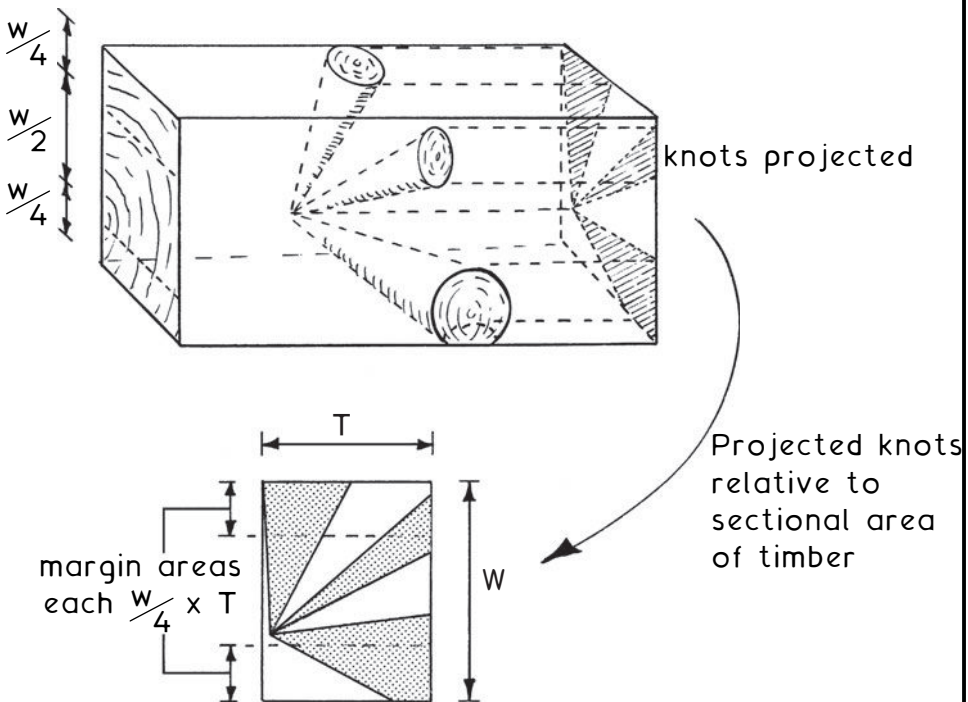

## Materials Testing – Softwood Timber Grading (2)

Fissures and resin pockets ~ defects in growth. Fissures, also known as shakes, are usually caused by separation of annual growth rings. Fissures and resin pockets must be limited in structural timber as they reduce resistance to shear and bending parallel to the grain.

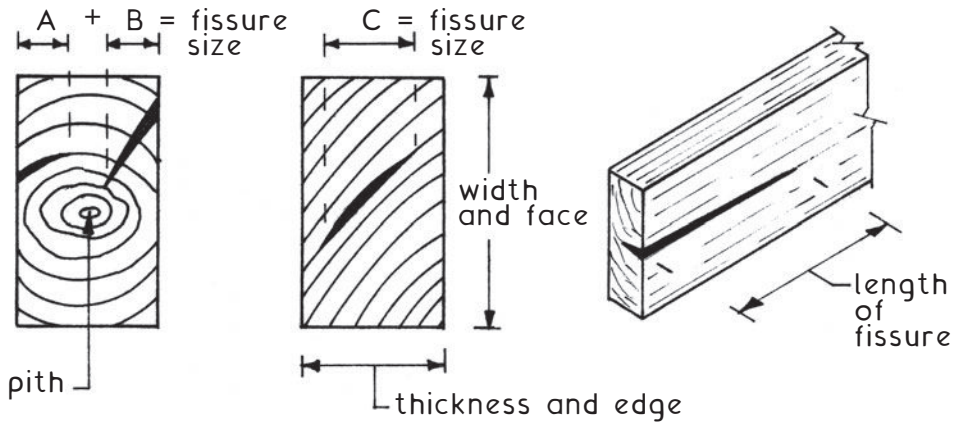

Slope of grain ~ an irregularity in growth or where the log is not cut parallel to the grain. If excessive this will produce a weakness in shear. Measurement is by scoring a line along the grain of the timber surface and comparing this with the parallel sides of the section.

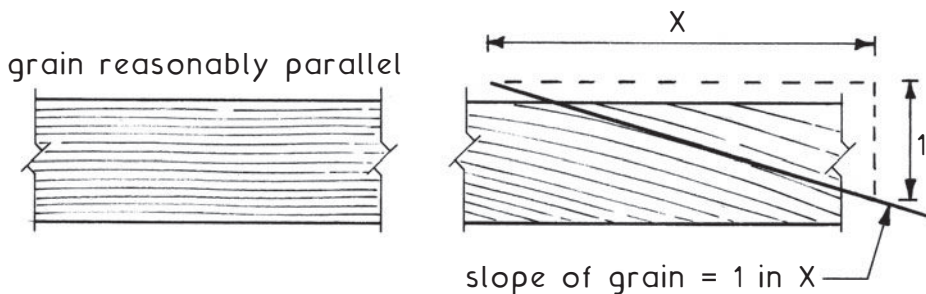

Insect damage ~ no active allowed. Woodworm holes acceptable if only nominal. Wood wasp holes not permitted.

Sapstain ~ acceptable.

Wane or waney edge ~ occurs on timber cut close to the outer surface of the log producing incomplete corners. Measurement is parallel to the edge or face of section and it is expressed as a fraction of the surface dimension.

Growth rate ~ measurement is applied to the annual growth ring separation averaged over a line 75mm long. If pith is present the line should commence 25mm beyond and if 75mm is impractical to achieve, the longest possible line is taken.

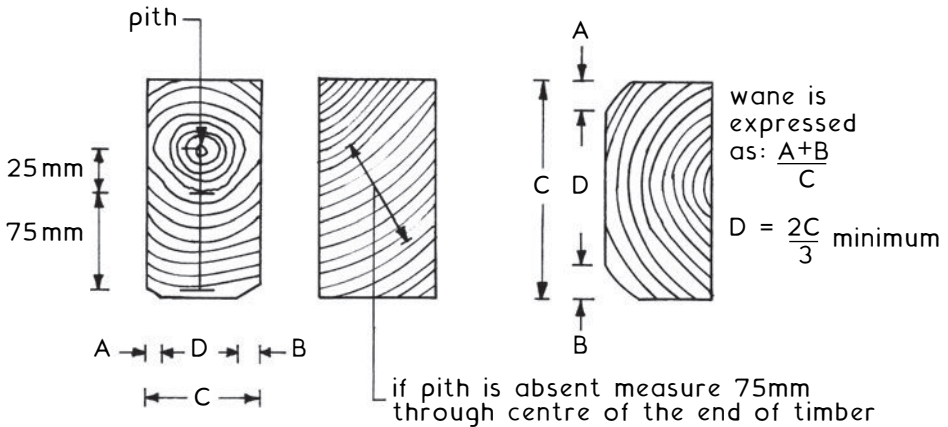

Distortion ~ measurement over the length and width of section to determine the amount of bow, spring and twist.

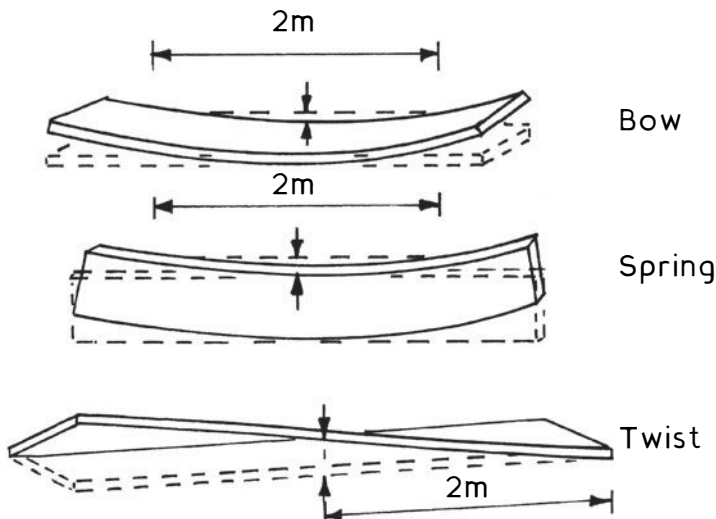

## Materials Testing – Softwood Timber Grading (4)

Characteristics and tolerances of GS and SS graded timber ~

Criteria	GS	SS
KAR: No margin condition	MKAR $\leq$ 1/2 TKAR $\leq$ 1/2	MKAR $\leq$ 1/2 TKAR $\leq$ 1/3
KAR: Margin condition	Or: MKAR $>$ 1/2 TKAR $\leq$ 1/3	MKAR $>$ 1/2 TKAR $\leq$ 1/5
Fissures and resin pockets: Not through thickness Through thickness	Defects $\leq$ 1/2 timber thick- ness <1.5 m or 1/2 timber length take lesser <1.0 m or 1/4 timber length take lesser If at ends fissure length maximum 2 $\times$ timber width	Defects $\leq$ 1/2 timber thickness <1.0 m or 1/4 timber length take lesser <0.5 m or 1/4 timber length take lesser If at ends fissure length < width of tim- ber section
Slope of grain:	Maximum 1 in 6	Maximum 1 in 10
Wane:	Maximum 1/3 of the full edge and face of the sec- tion - length not limited	
Resin pockets: Not through thickness Through thickness	Unlimited if shorter than width of section otherwise as for fissures Unlimited if shorter than 1/2 width of section other- wise as for fissures	
Growth rate of annual rings:	Average width or growth <10mm	Average width or growth <6mm
Distortion: -bow -spring -twist	<20 mm over 2m <12 mm over 2m <2 mm per 25mm width over 2m	<10 mm over 2m <8 mm over 2m <1 mm per 25mm width over 2m

Structural softwood cross-sectional size has established terminology such as sawn, basic and unwrought as produced by conversion of the log into commercial dimensions, e.g. 100 × 50mm and 225 × 75mm (4" × 2" and 9" × 3" respectively, as the nearest imperial sizes).

Timber is converted in imperial and metric sizes depending on its source in the world. Thereafter, standardisation can be undertaken by machine planing the surfaces to produce uniformly compatible and practically convenient dimensions, i.e. 225mm is not the same as 9". Planed timber has been variously described as nominal, regularised and wrought, e.g. 100 × 50mm sawn becomes 97 × 47mm when planed and is otherwise known as ex. 100 × 50mm, where ex means out of.

Guidance in BS EN 336 requires the sizes of timber from a supplier to be redefined as 'Target Sizes' within the following tolerances:

T1 ~ Thickness and width ≤ 100mm, -1 to +3mm.

Thickness and width > 100mm, -2 to +4mm.

T2 ~ Thickness and width ≤ 100mm, -1 to +1mm.

Thickness and width > 100mm, -1.5 to +1.5mm.

T1 applies to sawn timber, e.g. 100 × 75mm.

T2 applies to planed timber, e.g. 97 × 72mm.

Further example ~ a section of timber required to be 195mm planed × 50mm sawn is specified as: 195 (T2) × 50 (T1).

Target sizes for sawn softwood (T1) ~

50, 63, 75, 100, 125, 150, 175, 200, 225, 250 and 300mm.

Target sizes for planed/machined softwood (T2) ~

47, 60, 72, 97, 120, 145, 170, 195, 220, 245 and 295mm.

Ref. BS EN 336: Structural timber. Sizes, permitted deviations.



## Timber — Moisture Movement

Conversion ~ after timber is sawn into commercially useable sections, it is seasoned (oven dried) to a moisture content of between 10% and 15% depending on species.

$$\text{Moisture content} = \frac{\text{Mass when wet} - \text{Mass when dried}}{\text{Mass when dried}} \times 100\%$$

Protection ~ the moisture content of seasoned timber is much less than timber in its natural state, therefore timber will readily absorb water if it is unprotected.

The effects of water absorption may be:

- Deformities and distortion (see page 145).
- Rot and decay (see pages 149 and 150).
- Swelling and shrinkage.

Swelling and shrinkage will be most noticeable after fixing, unless the seasoned moisture content is maintained by correct storage at the suppliers, on site and by adequate protection in use.

Movement ~ shrinkage occurs as wood dries below its fibre saturation point. It will also expand if water is allowed to penetrate the open fibres. Volume change is not the same or even proportionally the same, as potential for movement varies directionally:

- Longitudinally - minimal, i.e. 0.1% to 0.3%.
- Transversely/radially - 2% to 6%.
- Tangentially - 5% to 10%.

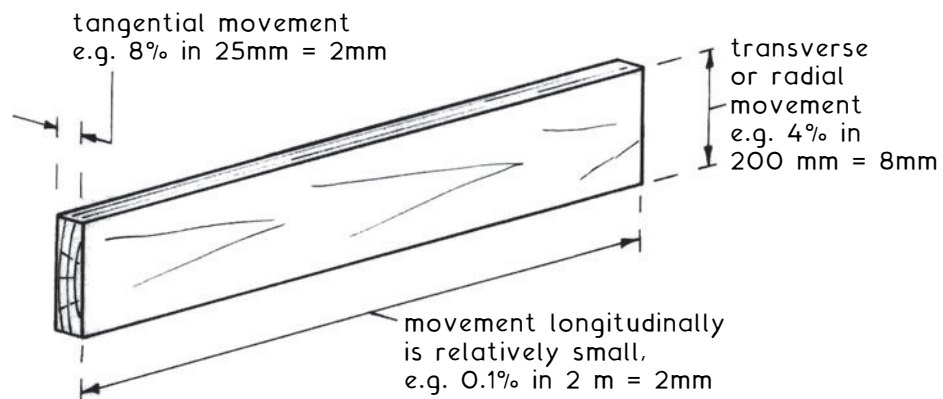

Damp conditions can be the source of many different types of wood-decaying fungi. The principal agencies of decay are:

- \* Dry rot (*Serpula lacrymans* or *merulius lacrymans*), and
- \* Wet rot (*Coniophora cerabella*)

Dry rot – this is the most difficult to control as its root system can penetrate damp and porous plaster, brickwork and concrete. It can also remain dormant until damp conditions encourage its growth, even though the original source of dampness is removed.

Appearance – white fungal threads which attract dampness from the air or adjacent materials. The threads develop strands bearing spores or seeds which drift with air movements to settle and germinate on timber having a moisture content exceeding about 25%. Fruiting bodies of a grey or red flat profile may also identify dry rot.

Typical surface appearance of dry rot –

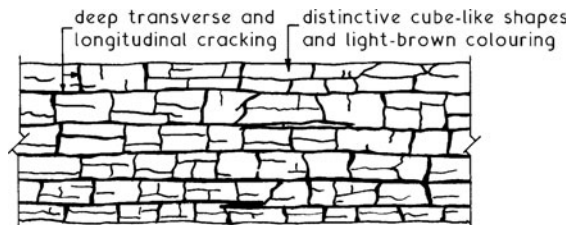

Wet rot – this is limited in its development and must have moisture continually present, e.g. a permanently leaking pipe or a faulty dpc. Growth pattern is similar to dry rot, but spores will not germinate in dry timber.

Appearance – fungal threads of black or dark-brown colour. Fruiting bodies may be olive-green or dark brown and these are often the first sign of decay.

Typical surface appearance of wet rot –

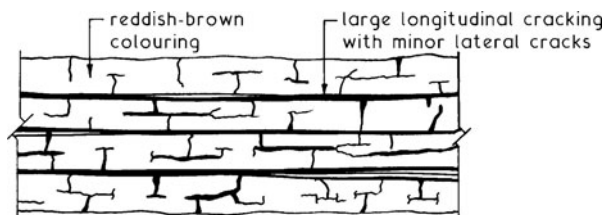

## Timber Rot — Causes, Treatment and Preservation

### Causes:

- \* Defective construction, e.g. broken roof tiles; no damp-proof course.
- \* Installation of wet timber during construction, e.g. framing sealed behind plasterboard linings; wet joists under floor decking.
- \* Lack of ventilation, e.g. blocked air-bricks to suspended timber ground floor; condensation in unventilated roof spaces.
- \* Defective water services, e.g. undetected leaks on internal pipework; blocked or broken rainwater pipes and guttering.

### General treatment:

- \* Remove source of dampness.
- \* Allow affected area to dry.
- \* Remove and burn all affected timber and sound timber within 500mm of fungal attack.
- \* Remove contaminated plaster and rake out adjacent mortar joints to masonry.

Note: This is normally sufficient treatment where wet rot is identified. However, where dry rot is apparent the following additional treatment is necessary:

- \* Sterilise surface of concrete and masonry.  
Heat with a blow torch until the surface is too hot to touch. Apply a proprietary fungicide† generously to warm surface. Irrigate badly affected masonry and floors, i.e. provide 12mm diameter boreholes at about 500mm spacing and flood or pressure inject with fungicide.

† 20:1 dilution of water and sodium pentachlorophenate, sodium orthophenylphate or mercuric chloride. Product manufacturers' safety in handling and use measures must be observed when applying these chemicals.

Replacement work should ensure that new timbers are pressure impregnated with a preservative. Cement and sand mixes for rendering, plastering and screeds should contain a zinc oxychloride fungicide.

### Further reading -

BRE: Timber pack (ref. AP 265) - various Digests, Information Papers, Good Repair Guides and Good Building Guides.

In-situ timber treatment using timber preservatives - HSE Books.

Ref. Bldg. Regs. Approved Document C. Site preparation and resistance to contaminants and moisture.

Trees are part of our national heritage and are also the source of timber. To maintain this source a control over tree felling has been established under the Forestry Act which places the control responsibility on the Forestry Commission. Local planning authorities also have powers under the Town and Country Planning Act and the Town and Country Amenities Act to protect trees by making tree preservation orders. A TPO may be applied if the LPA consider that it is "expedient in the interests of amenity to make provision for the preservation of trees or woodlands in their area" (Section 198[1] of the Town and Country Planning Act). Before cutting down, uprooting, severing roots, topping off, lopping, damaging or destroying a tree, a formal application must be submitted to the LPA for consent. Contravention of such an order can lead to a substantial fine and a compulsion to replace any protected tree which has been removed or destroyed. Trees on building sites which are covered by a tree preservation order should be protected by a suitable fence.

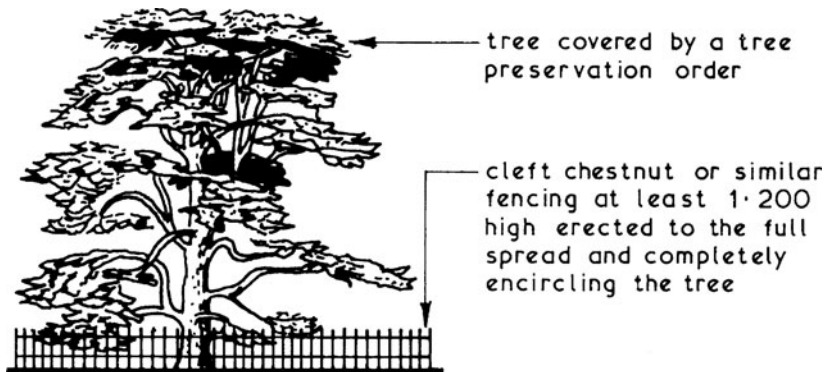

Definition and interpretation of what constitutes a tree (e.g. trunk diameter, overall height, etc.) will vary and may be considered subjective. Therefore, appeals will be considered. If upheld, an agreement for replacement trees is usual, in at least the same quantity of the same species within the proposed development site. Trees, shrubs, bushes and tree roots which are to be removed from site can usually be grubbed out using handheld tools such as saws, picks and spades. Where whole trees are to be removed for relocation special labour and equipment is required to ensure that the roots, root earth ball and bark are not damaged.

Ref. BS 5837: Trees in relation to design, demolition and construction, Recommendations.

## Protection Orders for Structures

Buildings of special historic or architectural interest are protected by provisions in the Planning (Listed Buildings and Conservation Areas) Act. English Heritage, funded by the Department for Culture, Media and Sport and from donations and commercial activities, is responsible for safeguarding and protecting the character of buildings that could otherwise be lost through demolition or unsympathetic alterations, extensions, modifications, refurbishment or inadequate maintenance.

Buildings considered to be a national asset and worthy of preservation are listed. Statutory listing applies to about half-a-million buildings. This status places responsibility on their owners to keep them in good order. These buildings are legally protected, therefore proposals for development on the site that they occupy as well as proposals for both internal and external alterations are subject to a listed building consent being obtained from the local planning authority.

Examples of the type of work may include the following:

- Extensions and any demolition.
- Removal of internal walls and floors.
- Changes to room layout.
- Window and door replacement.
- Painting of unpainted surfaces.
- Exposed plumbing and electrical installations.
- Alterations to internal features, e.g. doors, panelling, fireplaces.
- Changes to existing materials/colour specifications.
- Removal of finishes to expose brickwork and structural timber.

The LPA should be consulted about all proposed work. It is a fineable offence to alter the character of listed buildings without the necessary consent and an order can be imposed on the building owner to rectify matters at their expense.

Categories of listing ~

Grade I: Buildings of exceptional interest.

Grade II\*: Particularly important buildings of more than special interest.

Grade II: Buildings of special interest, warranting preservation; 90% of listed buildings are in this category.

The grading applies in England and Wales. Similar provisions exist for Northern Ireland and Scotland.

See also the Royal Commission on Historical Monuments.

Services which may be encountered on construction sites and the authority responsible are:

Water – Local Water Company

Electricity – transmission ~ RWE npower, EDF Energy and E-on.  
 distribution ~ In Britain there are 14 separate regional grids managed by licensed independent network operators, e.g. Electricity North West.

Gas – Local gas or energy service providers, e.g. British Gas.

Telephones – National Telecommunications Companies, e.g. BT, and Vodaphone.

Drainage – Local Authority unless a private drain when owner(s) is (are) responsible.

All the above authorities must be notified of any proposed new services and alterations or terminations to existing services before any work is carried out.

Locating Existing Services on Site ~

Method 1 – By reference to maps and plans prepared and issued by the respective responsible authority.

Method 2 – Using visual indicators ~

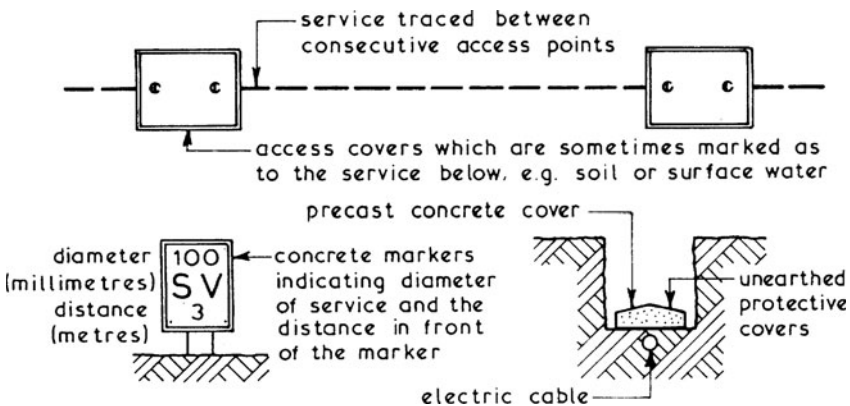

Method 3 – Detection specialist contractor employed to trace all forms of underground services using electronic subsurface survey equipment.

Once located, position and type of service can be plotted on a map or plan, marked with special paint on hard surfaces and marked with wood pegs with identification data on earth surfaces.

# Setting Out

Setting Out the Building Outline ~ this task is usually undertaken once the site has been cleared of any debris or obstructions and any reduced-level excavation work is finished. It is usually the responsibility of the contractor to set out the building(s) using the information provided by the designer or architect. Accurate setting out is of paramount importance and should therefore only be carried out by competent persons and all their work thoroughly checked, preferably by different personnel and by a different method.

The first task in setting out the building is to establish a baseline to which all the setting out can be related. The baseline very often coincides with the building line which is a line, whose position on site is given by the local authority in front of which no development is permitted.

## Typical Setting Out Example ~

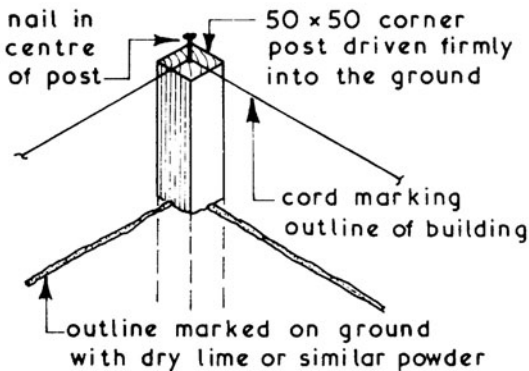
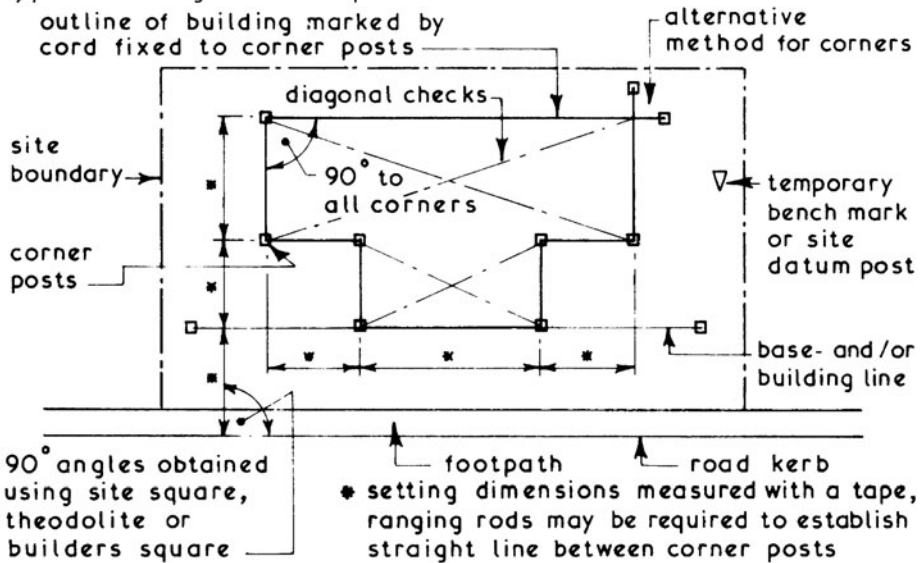

Temporary Bench mark: this is a fixed point on site to which all levels are related and should be established at an early stage in the contract. Where possible it should relate to an ordnance bench mark. On site it can be any permanent feature such as a drain cover or a firmly driven post.

Setting Out Trenches ~ the objective of this task is twofold. First, it must establish the excavation size, shape and direction; and second, it must establish the width and position of the walls. The outline of building will have been set out and using this outline profile boards can be set up to control the position, width and possibly the depth of the proposed trenches. Profile boards should be set up at least 2.000 clear of trench positions so that they do not obstruct the excavation work. The level of the profile crossboard should be related to the site datum and fixed at a convenient height above ground level if a traveller is to be used to control the depth of the trench. Alternatively the trench depth can be controlled using a level and staff related to site datum. The trench width can be marked on the profile with either nails or saw cuts and with a painted band if required for identification.

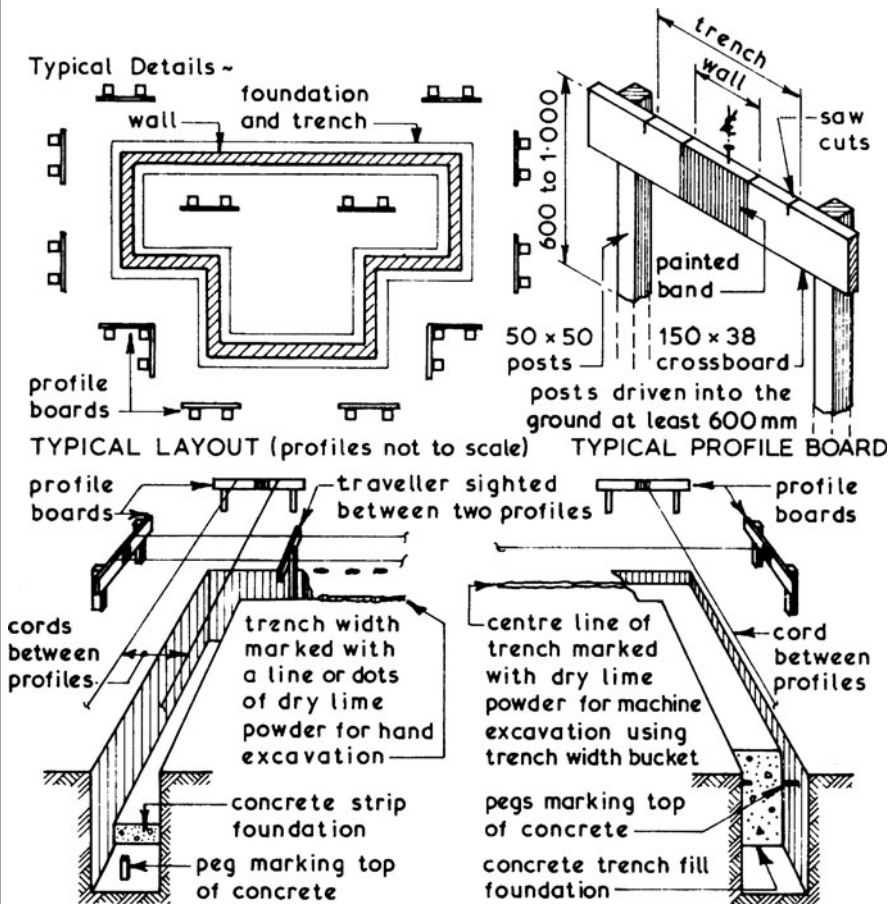

NB. Corners of walls transferred from intersecting cord lines to mortar spots on concrete foundations using a spirit level.



## Setting Out

Setting Out a Framed Building ~ framed buildings are usually related to a grid, the intersections of the grid lines being the centre point of an isolated or pad foundation. The grid is usually set out from a baseline which does not always form part of the grid. Setting out dimensions for locating the grid can either be given on a drawing or they will have to be accurately scaled off a general layout plan. The grid is established using a theodolite and marking the grid line intersections with stout pegs. Once the grid has been set out offset pegs or profiles can be fixed clear of any subsequent excavation work. Control of excavation depth can be by means of a traveller sighted between sight rails or by level and staff related to site datum.

### Typical Details ~

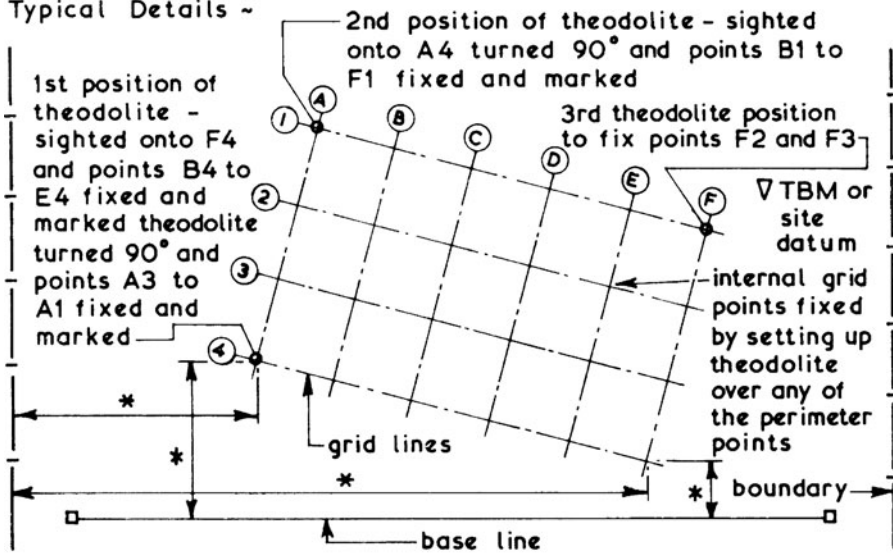

\* setting out dimensions to establish grid line A4 to F4

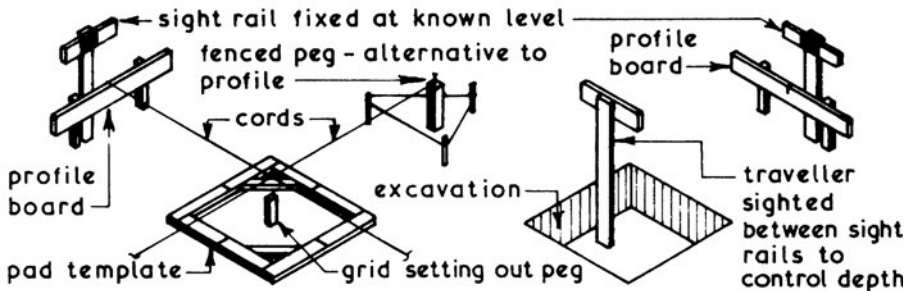

1. Pad template positioned with cords between profiles and pad outline marked with dry lime or similar powder.

2. Pad pits excavated using traveller sighted between sight rails fixed at a level related to site datum.

Setting Out Reduced Level Excavations ~ the overall outline of the reduced level area can be set out using a theodolite, ranging rods, tape and pegs working from a baseline. To control the depth of excavation, sight rails are set up at a convenient height and at positions which will enable a traveller to be used.

Typical Details ~

1. Setting up sight rails:

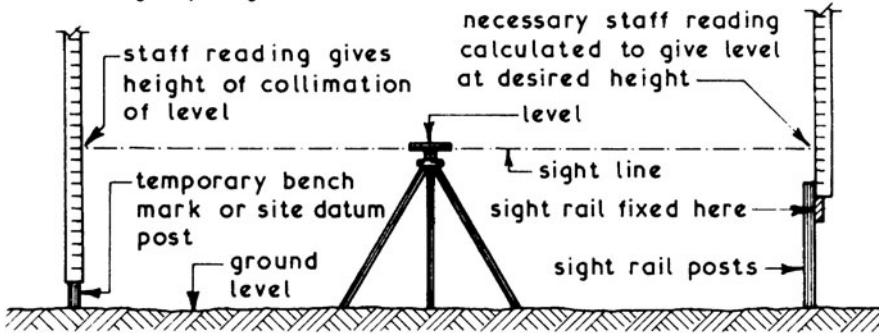

2. Controlling excavation depth:

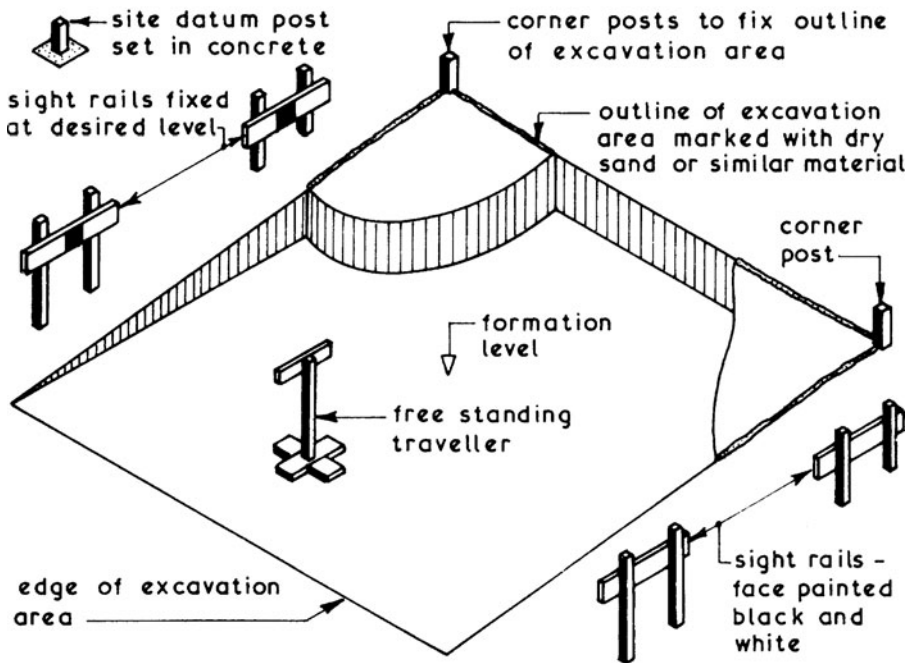

height of traveller = desired level of sight rail - formation level

## Setting Out – Datum

Datum ~ altitude zero taken at mean sea level. This varies between different countries, but for UK purposes it was established at Newlyn in Cornwall from tide data recorded between May 1915 and April 1921. Relative levels defined by bench marks are located throughout the country. The most common are identified as carved arrows cut into walls of permanent structures. Reference to Ordnance Survey maps of an area will indicate bench mark positions and their height above sea level, hence the name Ordnance Datum (OD).

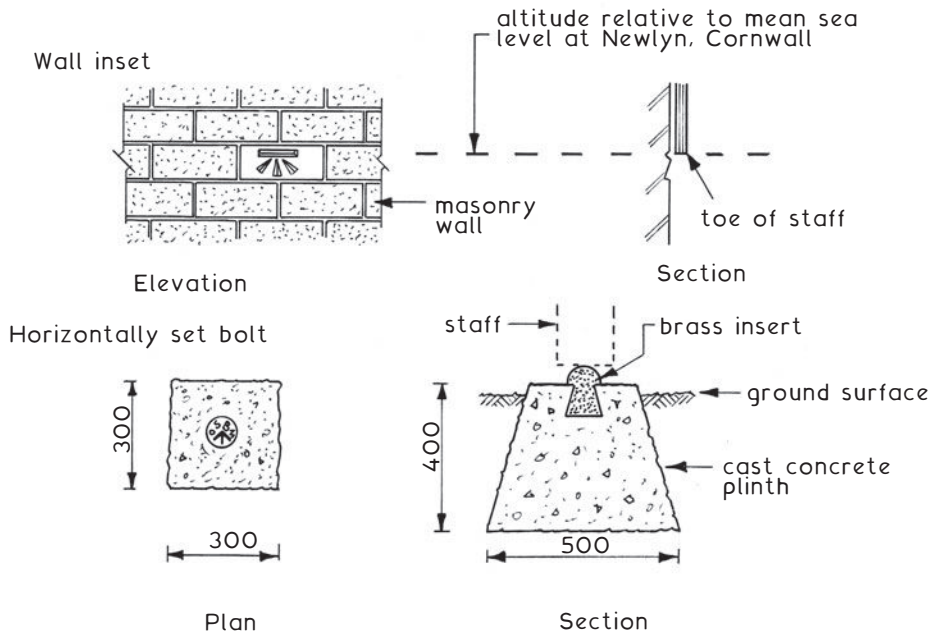

Taking site levels ~ the nearest OD bench mark may be impractical to access. The alternative is to establish a datum or temporary bench mark (TBM) from a fixture such as a manhole cover. Otherwise, a fixed position for a TBM could be a robust post set in concrete or a cast concrete plinth set in the ground to one side of ongoing work.

Instruments consist of a level (tilting or automatic) and a staff. A tilting level is basically a telescope mounted on a tripod for stability. Correcting screws establish accuracy in the horizontal plane by air bubble in a vial and focus is by adjustable lens. Cross hairs of horizontal and vertical lines indicate image sharpness on an extending staff of 3, 4 or 5m length. Staff graduations are in 10mm intervals on an "E" pattern as shown on the next page. Estimates are taken to the nearest millimetre. An automatic level is much simpler to use, eliminating the need for manual adjustment. It is approximately levelled by centre bulb bubble. A compensator within the telescope effects fine adjustment.

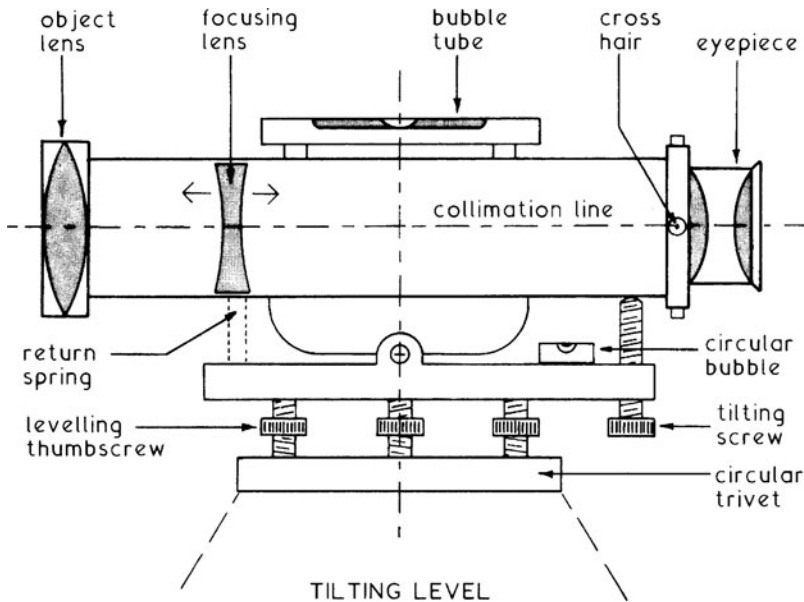

Taking levels ~ an Ordnance Datum bench mark or a temporary bench mark is located. The levelling instrument and tripod are positioned on firm ground and sighted to the bench mark. Further staff height readings are taken at established positions around the site or at measured intervals corresponding to a grid pattern at convenient intervals, typically 10m. Each intersection of the grid lines represents a staff position, otherwise known as a station. Levels taken from the staff readings (4 No. from the grid corners) are computed with the plan area calculations ( $100\text{m}^2$  for a 10m grid). From this the volume of site excavation or cut and fill required to level the site can be calculated.

## Setting Out – Application

Application ~ methods to determine differences in ground levels for calculation of site excavation volumes and costs.

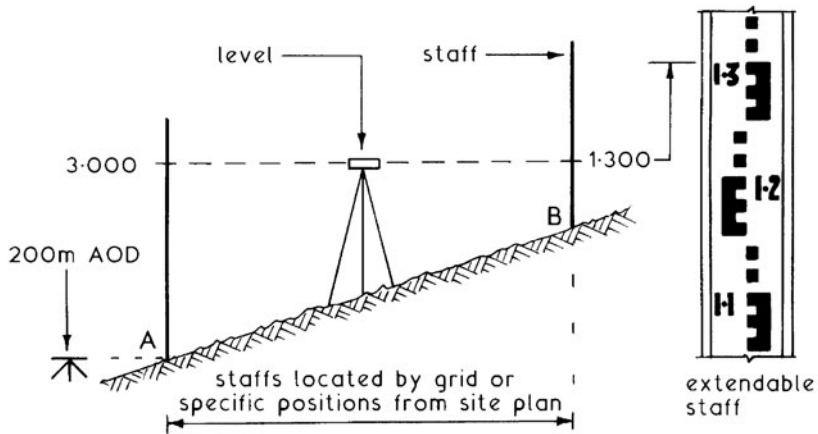

Rise and fall:

Staff reading at A = 3.00m, B = 1.30m

Ground level at A = 200m above ordnance datum (AOD)

Therefore level at B = 200m + rise (- fall if declining)

So level at B =  $200 + (3.00 - 1.30) = 201.7\text{m}$

Height of collimation (HC):

HC at A = Reduced level (RL) + staff reading  
 $= 200\text{ m} + 3.00\text{m} = 203\text{m AOD}$

Level at B = HC at A - staff reading at B  
 $= 203 - 1.30 = 201.7\text{m}$

height above mean  
sea level at Newlyn

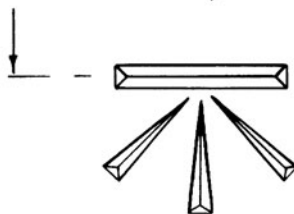

carved bench mark

cross  
hairs

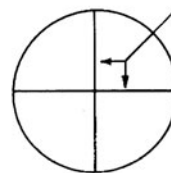

view through level

Theodolite - a tripod mounted instrument designed to measure angles in the horizontal or vertical plane.

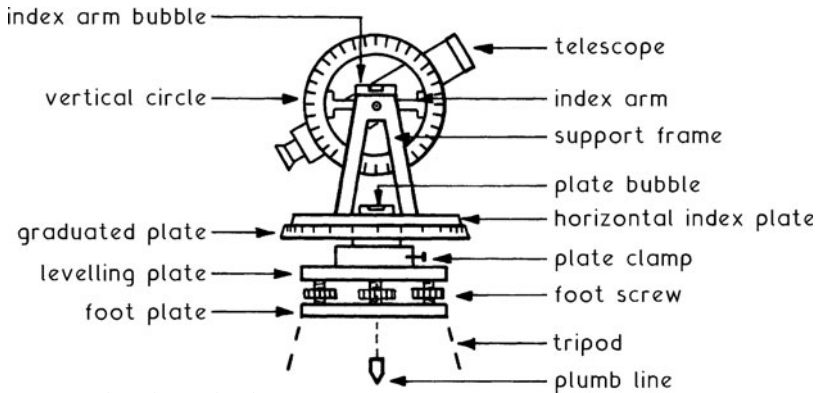

The theodolite in principle

Measurement - a telescope provides for focal location between instrument and subject. Position of the scope is defined by an index of angles. The scale and presentation of angles varies from traditional micrometer readings to computer-compatible crystal displays. Angles are measured in degrees, minutes and seconds, e.g.  $165^{\circ} 53' 30''$ .

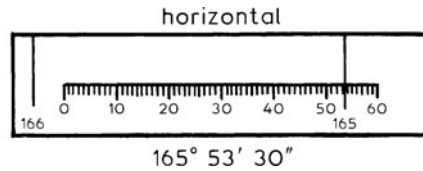
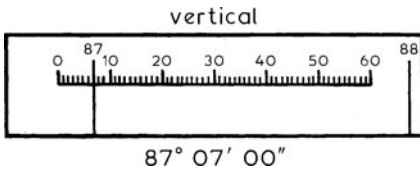

Direct reading micrometer scale

Application - at least two sightings are taken and the readings averaged. After the first sighting, the horizontal plate is rotated through  $180^{\circ}$  and the scope is also rotated  $180^{\circ}$  through the vertical to return the instrument to its original alignment for the second reading. This process will move the vertical circle from right face to left face, or vice versa. It is important to note the readings against the facing - see below.

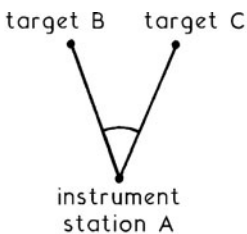

station - target	left face	right face	mean
A-B	$00^{\circ} 00' 00''$	$180^{\circ} 00' 30''$	$00^{\circ} 00' 15''$
A-C	$40^{\circ} 10' 10''$	$220^{\circ} 10' 30''$	$40^{\circ} 10' 20''$

Angle =  $40^{\circ} 10' 05''$

Defining an angle

## Road Construction (1)

Road Construction ~ within the context of building operations roadworks usually consist of the construction of small estate roads, access roads and driveways together with temporary roads laid to define site circulation routes and/or provide a suitable surface for plant movements. The construction of roads can be considered under three headings:

1. Setting out (this and next two pages).
2. Earthworks (see page 165).
3. Paving Construction (see pages 165-167).

Setting Out Roads ~ this activity is usually carried out after the topsoil has been removed using the dimensions given on the layout drawing(s). The layout could include straight lengths junctions, hammer heads, turning bays and intersecting curves.

Straight Road Lengths - these are usually set out from centre lines which have been established by traditional means

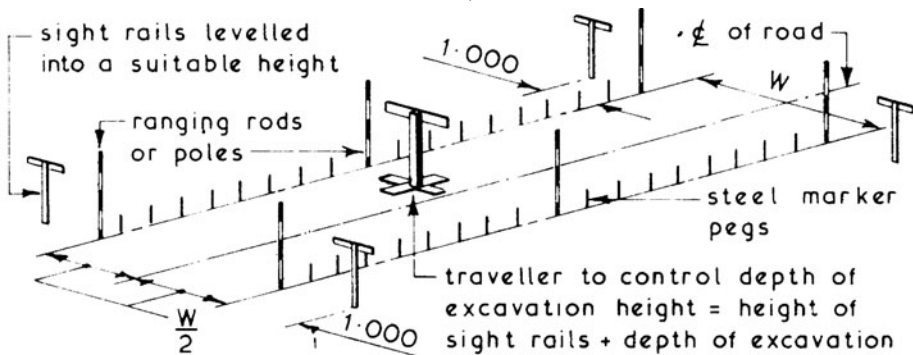

NB. curve road lengths set out in a similar manner

### Junctions and Hammer Heads -

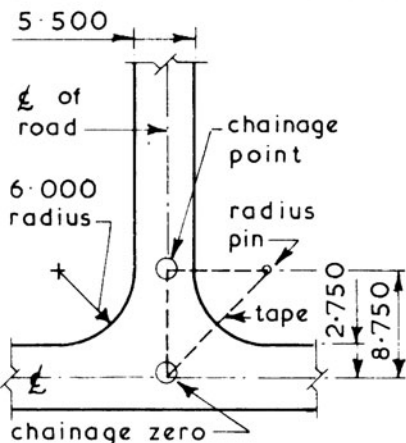

Centre lines fixed by traditional methods. Tape hooked over pin at chainage zero and passed around chainage point pin at 8.750 then returned to chainage zero via the radius pin with a tape length of 29.875. Radius pin held tape length 17.500 and tape is moved until tight between all pins. Radius pin is driven and a 6.000 tape length is swung from the pin to trace out curve which is marked with pegs or pins

$$\begin{aligned} \text{Tape length} &= 17.50 + \sqrt{2} \times 8.75 \\ &= 29.875 \end{aligned}$$

Lane Width ~ established by assessment of the amount of traffic flow and speed restriction. For convenience of road users, the minimum width can be based on a vehicle width not exceeding 2.500m plus an allowance for clearance of at least 0.500m between vehicles. This will provide an overall dimension of 5.500m for two-way traffic. One-way traffic will require a lane width of at least 3.000m.

Road Junctions ~ drivers of vehicles approaching a junction from any direction should have a clear view of other road users. Unobstructed visibility is required within vertical sight lines, triangular on plan. These provide a distance and area within which other vehicles and pedestrians can be seen at specific heights above the carriageway. No street furniture, trees or other obstructions are permitted within these zones, as indicated in the diagram below and on the next page.

Vertical Sight Lines ~ vertical in height and horizontal or near horizontal for driver and pedestrian visibility. These clear sight lines are established between a driver's eye height of between 1.050m and 2.000m to allow for varying vehicle heights, to an object height of between 0.600m and 2.000m over the horizontal plane.

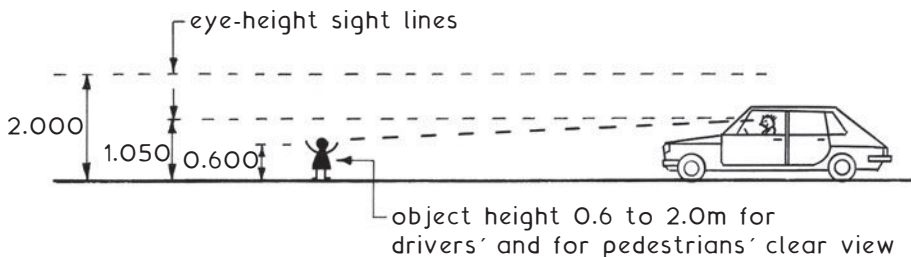



## Road Construction (3)

Horizontal Sight Lines ~ these should be provided and maintained thereafter with a clear view, to prevent the possibility of danger from vehicle drivers having obstructed outlook when approaching junctions. The recommended dimensions vary relative to the category of road classification and the speed restriction.

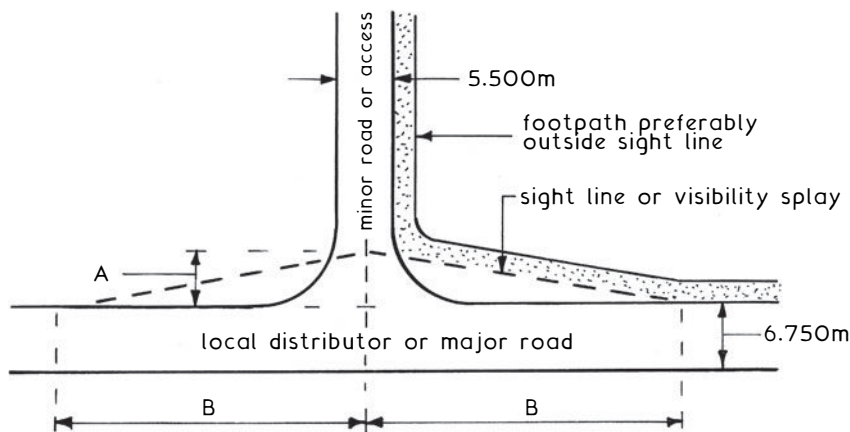

Guidance for dimensions A and B ~

Type of road	Min. dimension A (m)
Access to a single dwelling or a small development of about half-a-dozen units	2.0
Minor road junctions within developed areas	2.4
Minor road junctions at local distributor roads	4.5
Busy minor road junctions, access roads, district or local distributor roads and other major junctions	9.0

Speed restriction mph (kph)	Min. major road dimension B (m)
20 (32)	45
30 (48)	90
40 (64)	120
50 (80)	160
60 (90)	215
70 (112)	295

Refs.: Planning Policy Guidance (PPG) 13, DCLG. Manual for Streets, DfT and DCLG. Manual for Streets 2, The Chartered Institution of Highways and Transport.

Earthworks ~ this will involve the removal of topsoil together with any vegetation, scraping and grading the required area down to formation level plus the formation of any cuttings or embankments. Suitable plant for these operations would be tractor shovels fitted with a 4 in 1 bucket (page 208); graders (page 207) and bulldozers (page 205). The soil immediately below the formation level is called the subgrade whose strength will generally decrease as its moisture content rises; therefore if it is to be left exposed for any length of time protection may be required. Subgrade protection may take the form of a covering of medium-gauge plastic sheeting with generous overlaps. To preserve the strength and durability of the subgrade it may be necessary to install cut off subsoil drains alongside the proposed road (see Road Drainage on page 876).

Paving Construction ~ once the subgrade has been prepared and any drainage or other buried services installed the construction of the paving can be undertaken. Paved surfaces can be either flexible or rigid in format. Flexible or bound surfaces are formed of materials applied in layers directly over the subgrade whereas rigid pavings consist of a concrete slab resting on a granular base (see pages 166 and 167).

#### Typical Flexible Paving Details ~

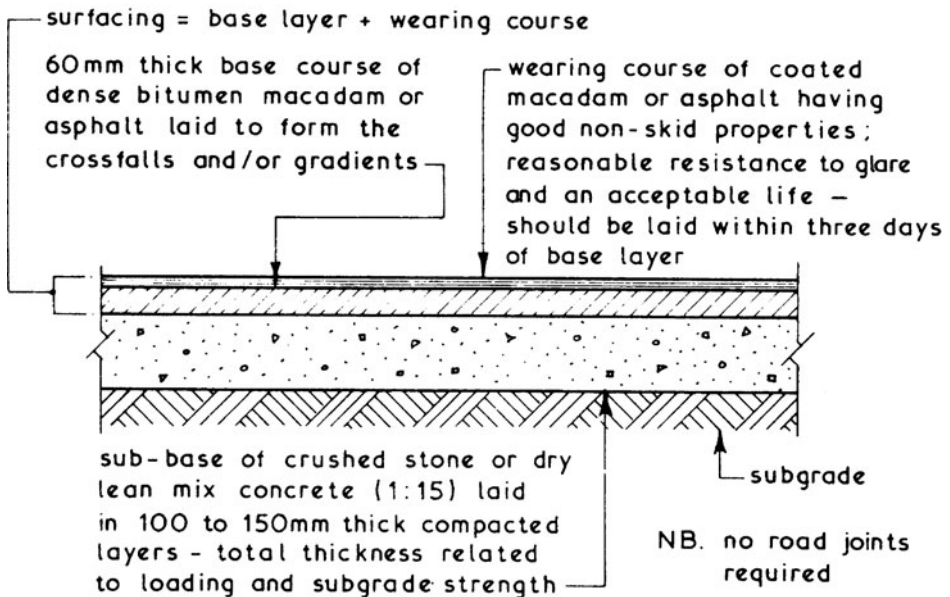

## Road Construction (5)

Rigid Pavings ~ these consist of a reinforced or unreinforced in-situ concrete slab laid over a base course of crushed stone or similar material which has been blinded to receive a polythene sheet slip membrane. The primary objective of this membrane is to prevent grout loss from the in-situ slab.

### Typical Rigid Paving Details ~

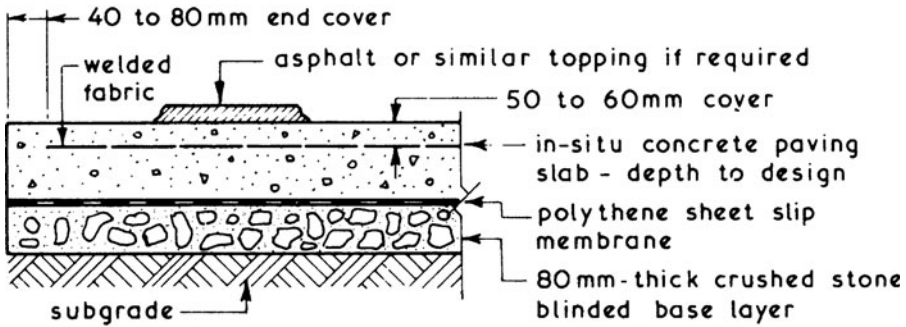

The paving can be laid between metal road forms or timber edge formwork. Alternatively the kerb stones could be laid first to act as permanent formwork.

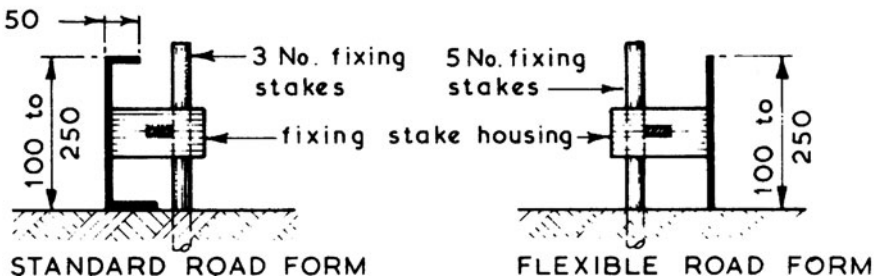
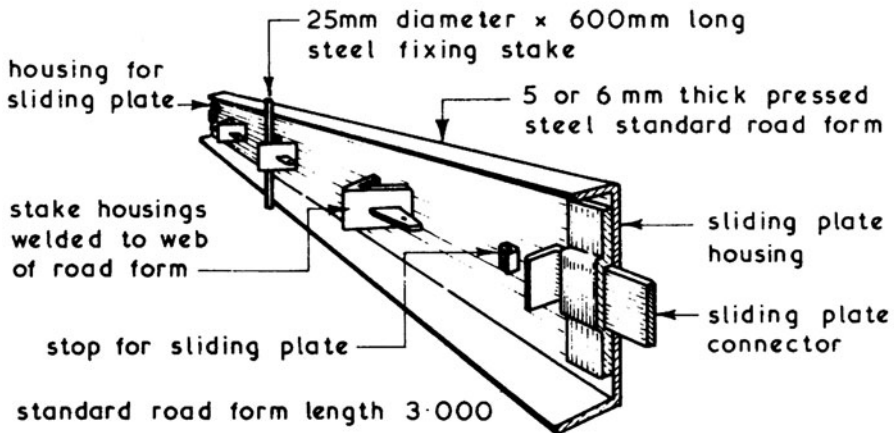

Joints in Rigid Pavings ~ longitudinal and transverse joints are required in rigid pavings to:

1. Limit size of slab.
2. Limit stresses due to subgrade restraint.
3. Provide for expansion and contraction movements.

The main joints used are classified as expansion, contraction or longitudinal, the latter being the same in detail as the contraction joint differing only in direction. The spacing of road joints is determined by:

1. Slab thickness.
2. Whether slab is reinforced or unreinforced.
3. Anticipated traffic load and flow rate.
4. Temperature at which concrete is laid.

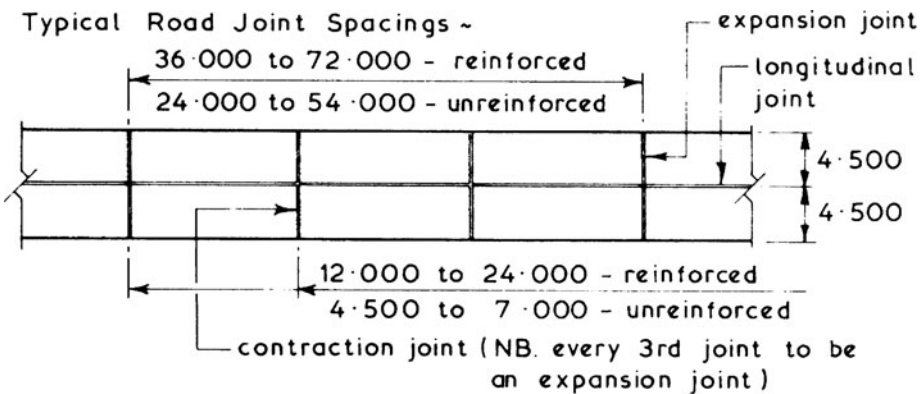

Typical Road Joint Details ~

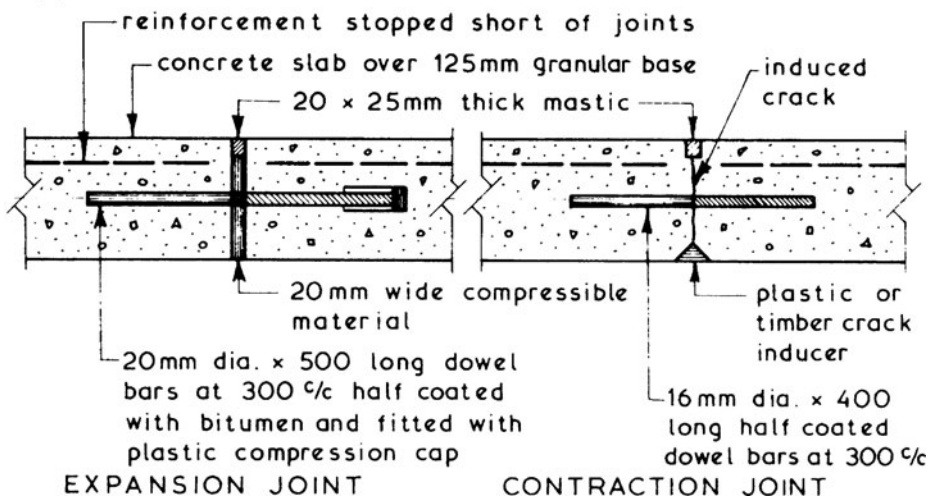

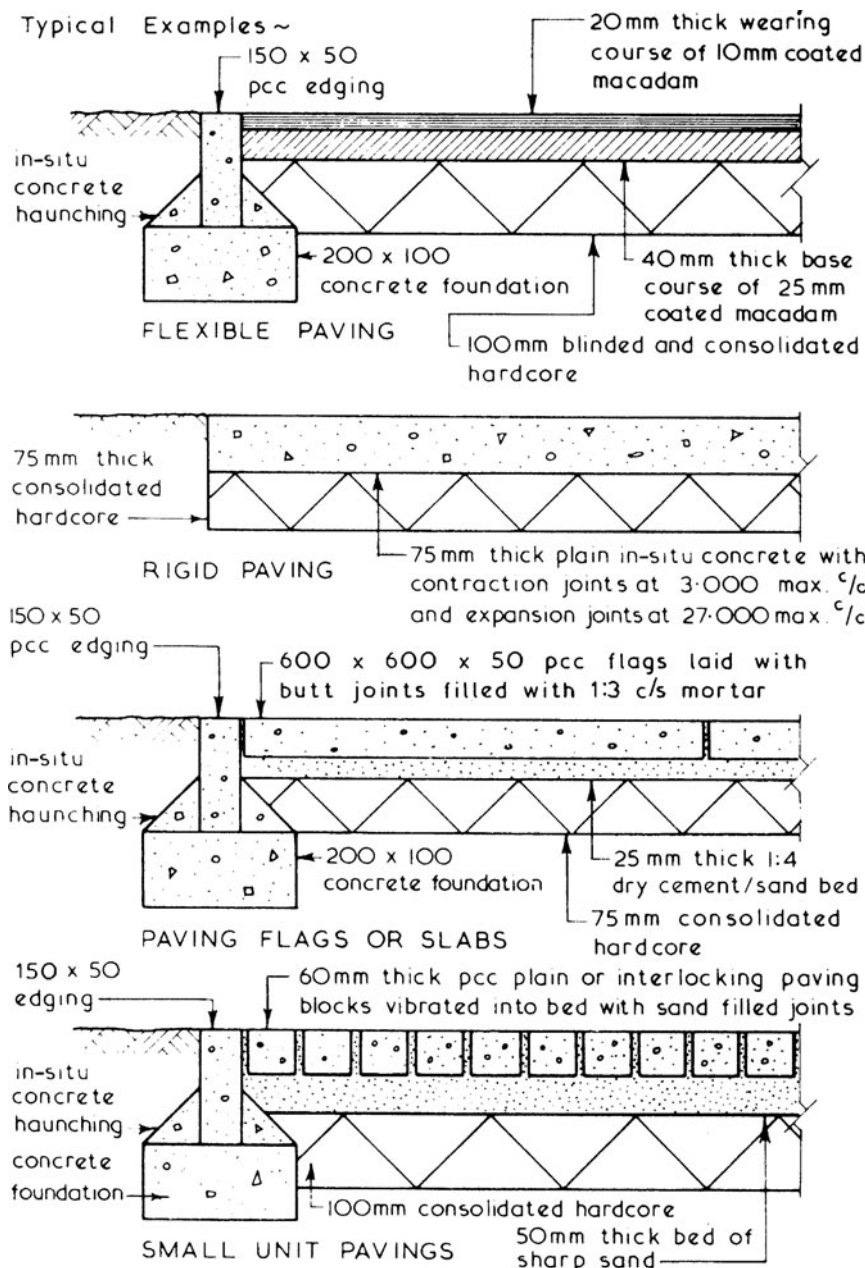

All pavings should be laid to a minimum fall of 1:60 to drain to one or both sides and have a minimum footpath width of 1.200  
 Refs.: BS 7533-4: Code of practice for construction of pavements.

- BS EN 1340: Concrete kerb units.
- BS EN 13108-1: Bituminous mixtures. Material specification. Asphalt concrete.
- BS EN 13108-7: Bituminous mixtures. Material specification. Porous asphalt.

Available sections ~ manufactured in 915mm lengths from silver/grey aggregate concrete.

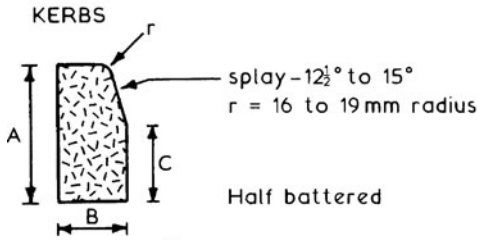

size (mm)				
A	150	150	255	305
B	125	150	125	150
C	50	50	155	205

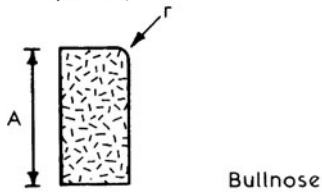

size (mm)				
A	150	150	255	305
B	125	150	125	150

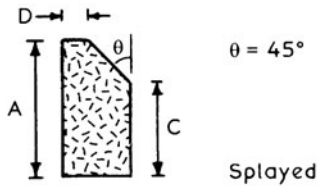

size (mm)			
A	150	255	305
B	125	125	150
C	75	180	230
D	50	50	75

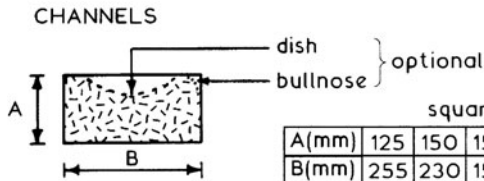

	square				dished				bullnose	
A(mm)	125	150	150	125	150	90	125	75	150	125
B(mm)	255	230	150	150	305	305	255	230	305	255

**EDGINGS**

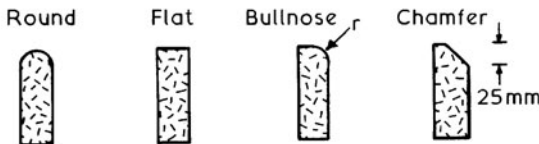

Round	150/200/250 × 50mm*
Flat	150/200/250 × 50mm*
Bullnose	150/200 × 50mm*
Chamfer	178 × 63mm

\*denotes BS sections

NB. Further components such as drop/tapered kerbs are available for vehicle accesses. Quadrants and angles provide for directional change.

## Roads – Kerbs, Pavings and Edgings

Concrete paving flags – BS dimensions:

Type	Size (nominal)	Size (work)	Thickness (T)
A – plain	600 × 450	598 × 448	50 or 63
B – plain	600 × 600	598 × 598	50 or 63
C – plain	600 × 750	598 × 748	50 or 63
D – plain	600 × 900	598 × 898	50 or 63
E – plain	450 × 450	448 × 448	50 or 70
TA/E – tactile	450 × 450	448 × 448	50 or 70
TA/F – tactile	400 × 400	398 × 398	50 or 65
TA/G – tactile	300 × 300	298 × 298	50 or 60

Note: All dimensions in millimetres.

Tactile flags – manufactured with a blistered (shown) or ribbed surface. Used in walkways to provide warning of hazards or to enable recognition of locations for people whose visibility is impaired. See also Department of Transport Disability Circular DU 1/86[1], for uses and applications.

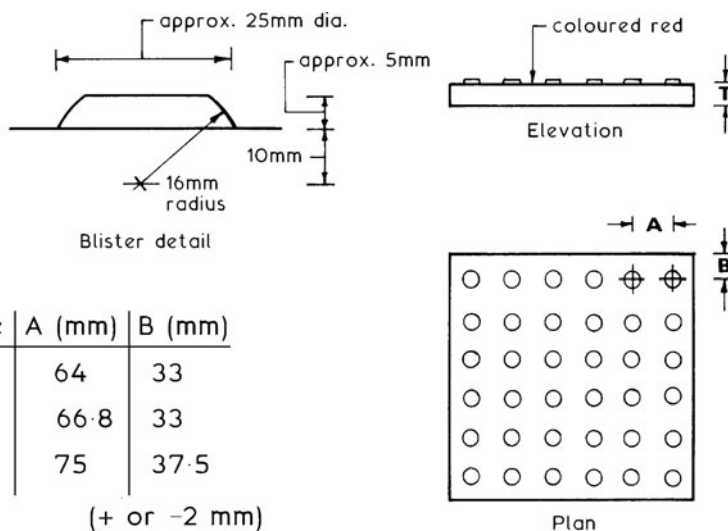

Ref. BS EN 1339: Concrete paving flags. Requirements and test methods.

Landscaping ~ in the context of building works this would involve reinstatement of the site as a preparation to the landscaping in the form of lawns, paths, pavings, flower and shrub beds and tree planting. The actual planning, lawn laying and planting activities are normally undertaken by a landscape subcontractor. The main contractor's work would involve clearing away all waste and unwanted materials, breaking up and levelling surface areas, removing all unwanted vegetation, preparing the subsoil for and spreading topsoil to a depth of at least 150mm.

Services ~ the actual position and laying of services is the responsibility of the various service boards and undertakings. The best method is to use the common trench approach; avoid as far as practicable laying services under the highway.

Typical Common Trench Details ~

trench backfilled with selected granular material in 200mm thick compacted layers

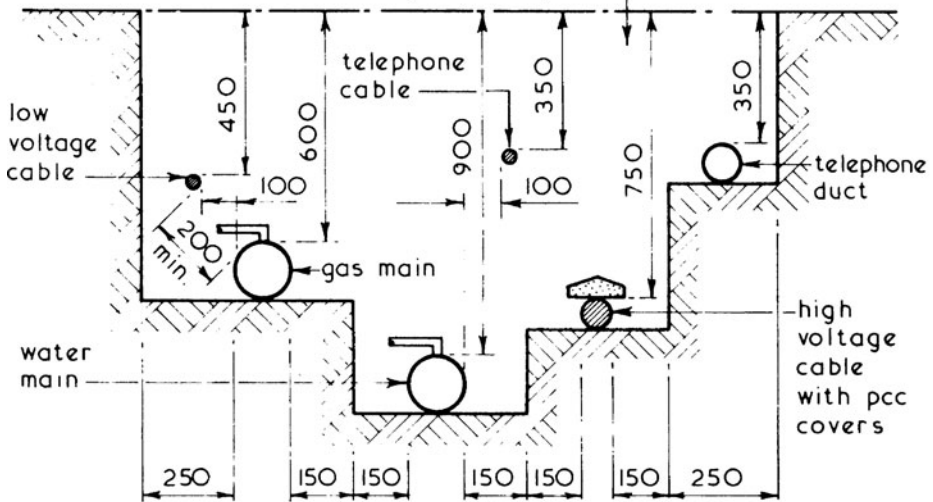

Road Signs ~ these can range from markings painted on roads to define traffic lanes, rights of way and warnings of hazards to signs mounted above the road level to give information, warning or directives, the latter being obligatory. See also, pages 56 and 57.

Typical Examples ~





# Tubular Scaffolding

Scaffolds ~ temporary platforms to provide a safe working place at a convenient height. Usually required when the working height is 1.500 or more above ground level.

Component Parts of a Tubular Scaffold ~

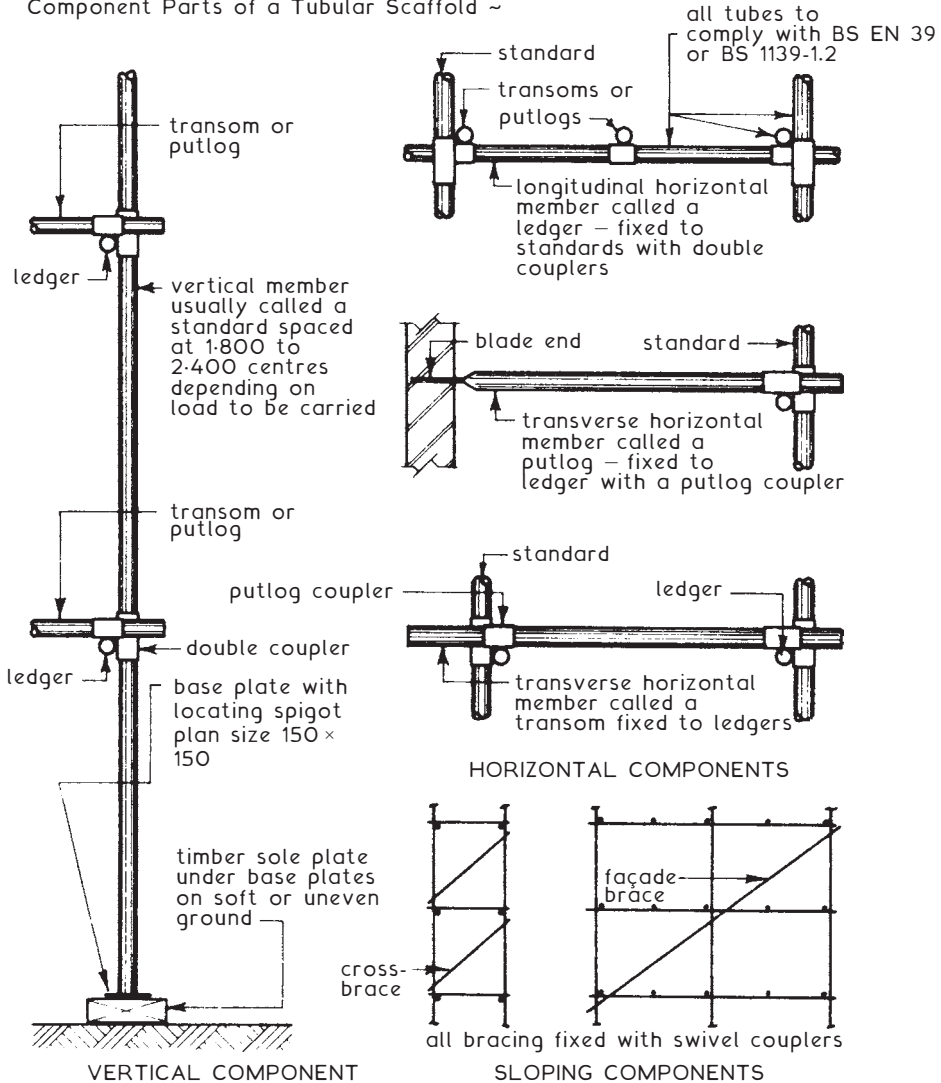

Refs.: BS EN 39: Loose steel tubes for tube and coupler scaffolds.  
 BS 1139-1.2: Metal scaffolding. Tubes. Specification for aluminium tube.  
 BS EN 12811-1: Temporary equipment. Scaffolds. Performance requirements and general design.  
 Work at Height Regulations.  
 Occupational Health and Safety Act. Scaffold regulations.

Putlog Scaffolds ~ these are scaffolds which have an outer row of standards joined together by ledgers which in turn support the transverse putlogs which are built into the bed joints or perpend as the work proceeds; they are therefore only suitable for new work in bricks or blocks.

Typical Details ~

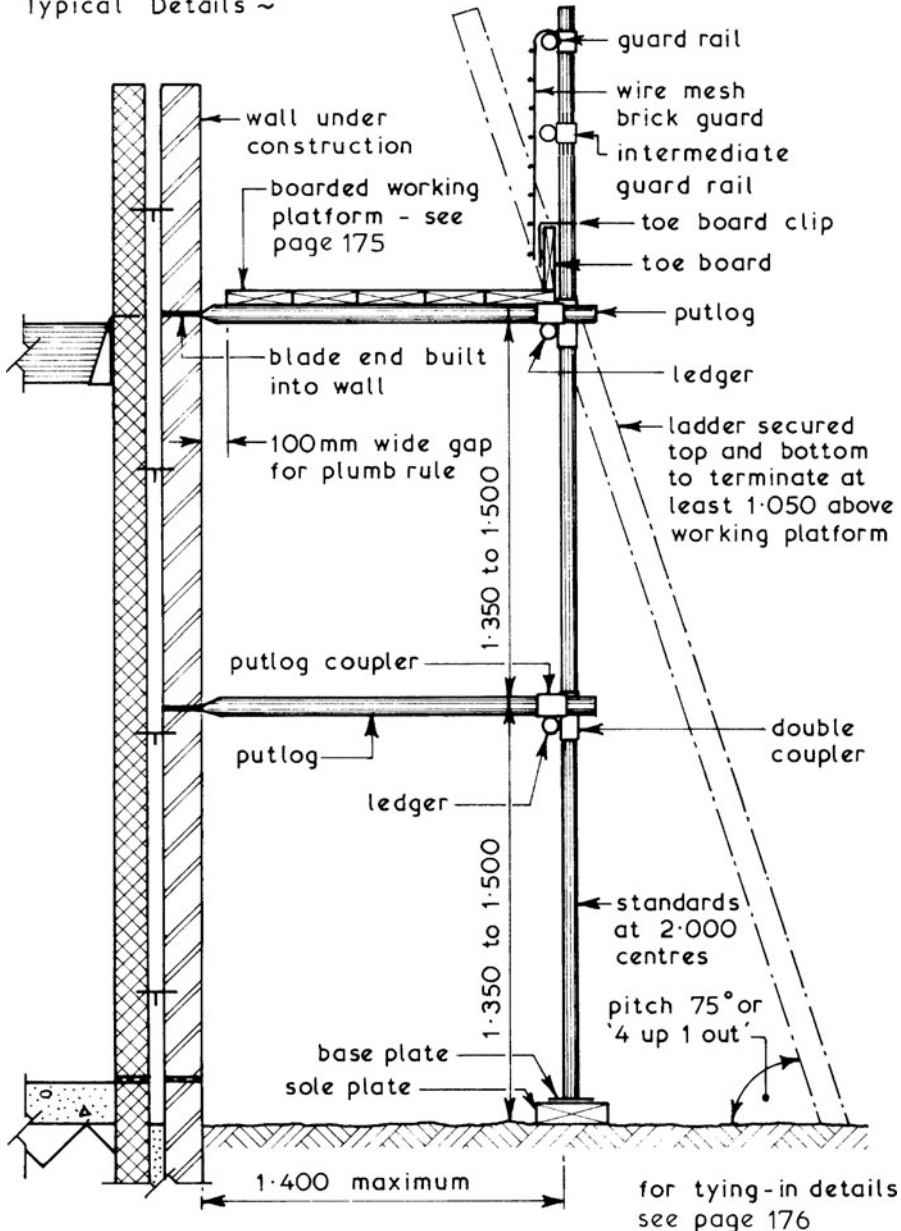

# Tubular Scaffolding

Independent Scaffolds ~ these are scaffolds which have two rows of standards, each row joined together with ledgers which in turn support the transverse transoms. The scaffold is erected clear of the existing or proposed building but is tied to the building or structure at suitable intervals - see page 176.

Typical Details ~

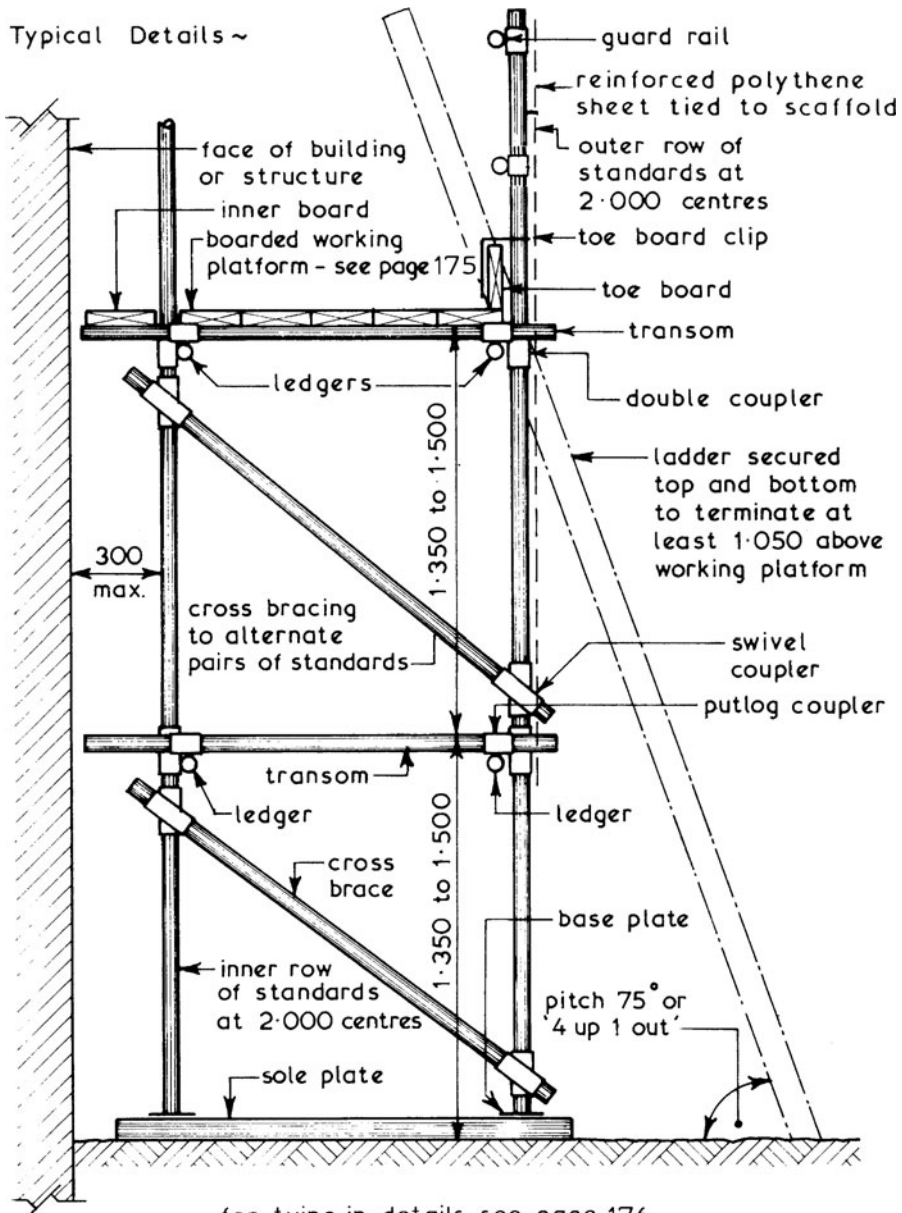

Working Platforms ~ these are close-boarded or plated level surfaces at a height at which work is being carried out and they must provide a safe working place of sufficient strength to support the imposed loads of operatives and/or materials. All working platforms above ground level must be fitted with a toe board and a guard rail.

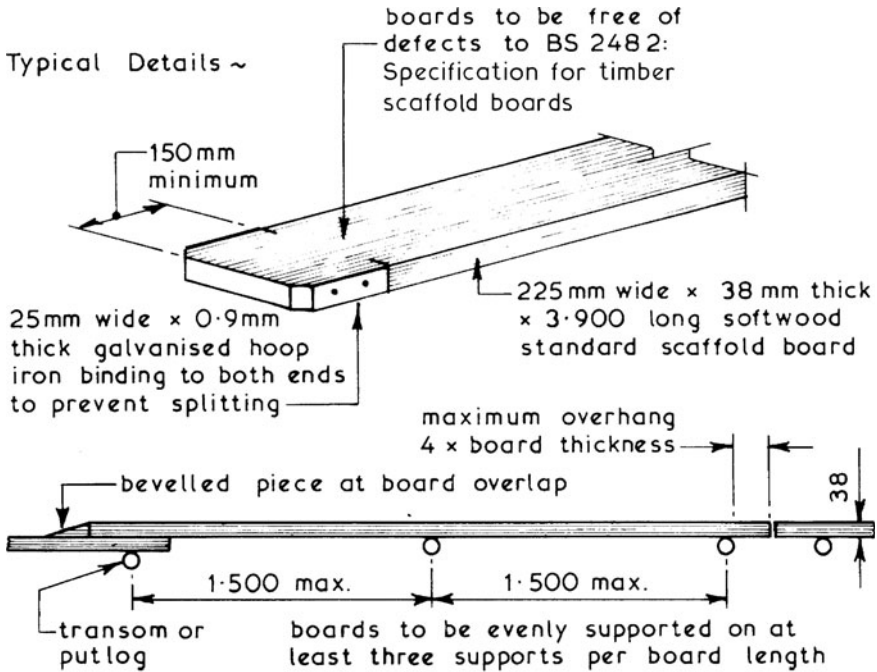

SCAFFOLD BOARDS FOR WORKING PLATFORMS

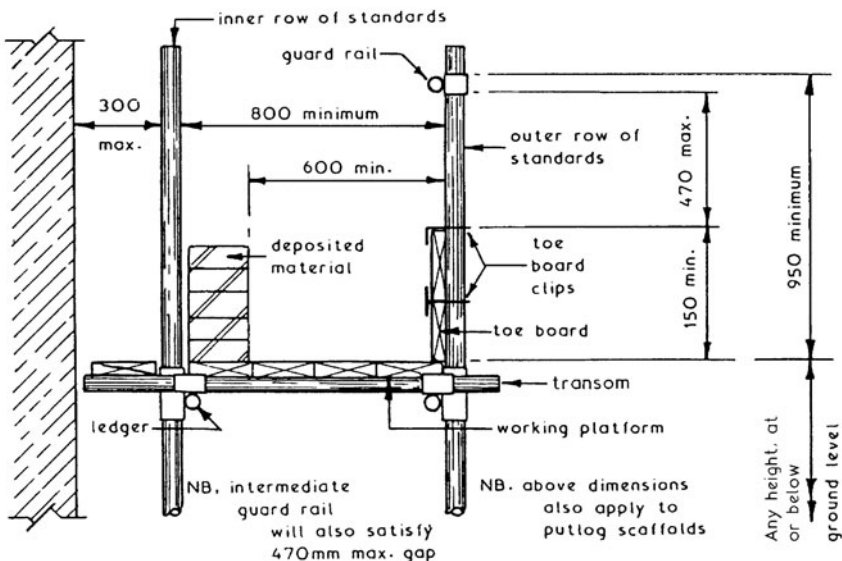

# Tubular Scaffolding

Tying-in ~ all putlog and independent scaffolds should be tied securely to the building or structure at alternate lift heights vertically and at not more than 6.000 centres horizontally. Putlogs should not be classified as ties.

Suitable tying-in methods include connecting to tubes fitted between sides of window openings or to internal tubes fitted across window openings; the former method should not be used for more than 50% of the total number of ties. If there is an insufficient number of window openings for the required number of ties external rakers should be used.

## Typical Details ~

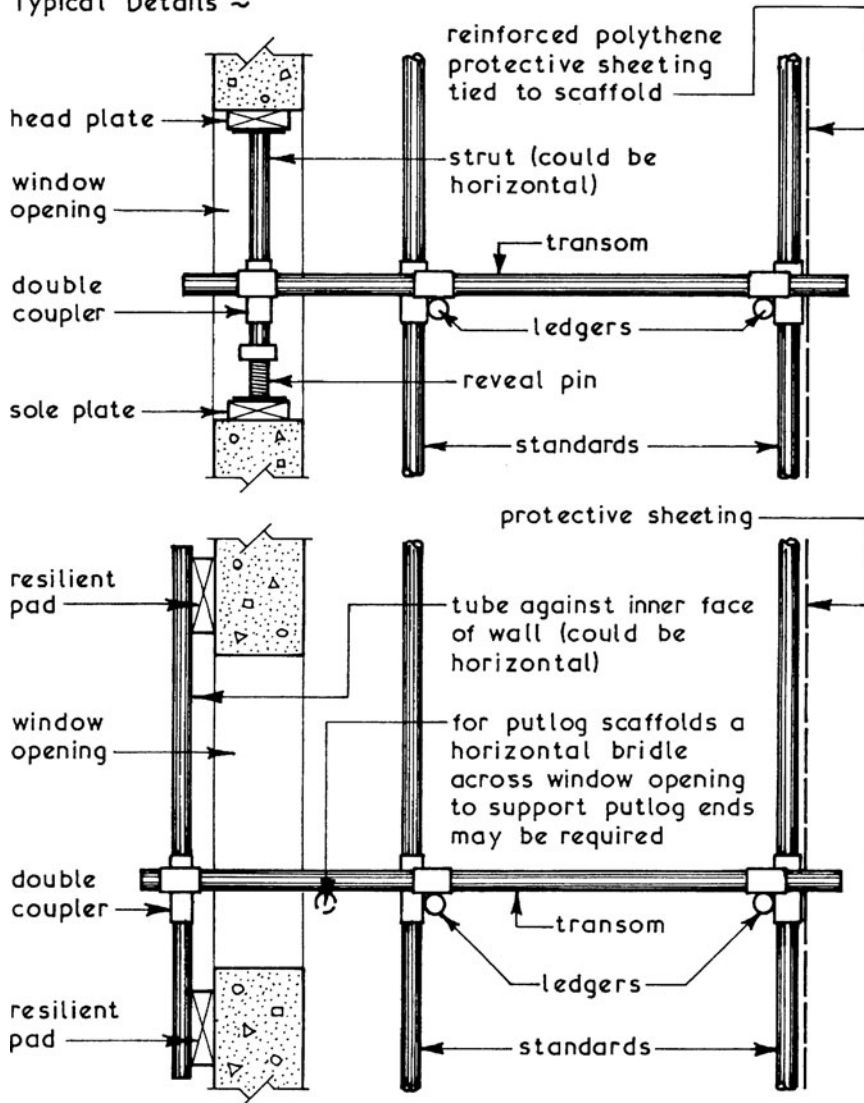

Mobile Scaffolds ~ otherwise known as mobile tower scaffolds. They can be assembled from preformed framing components or from standard scaffold tube and fittings. Used mainly for property maintenance. Must not be moved whilst occupied by persons or equipment.

Typical detail ~

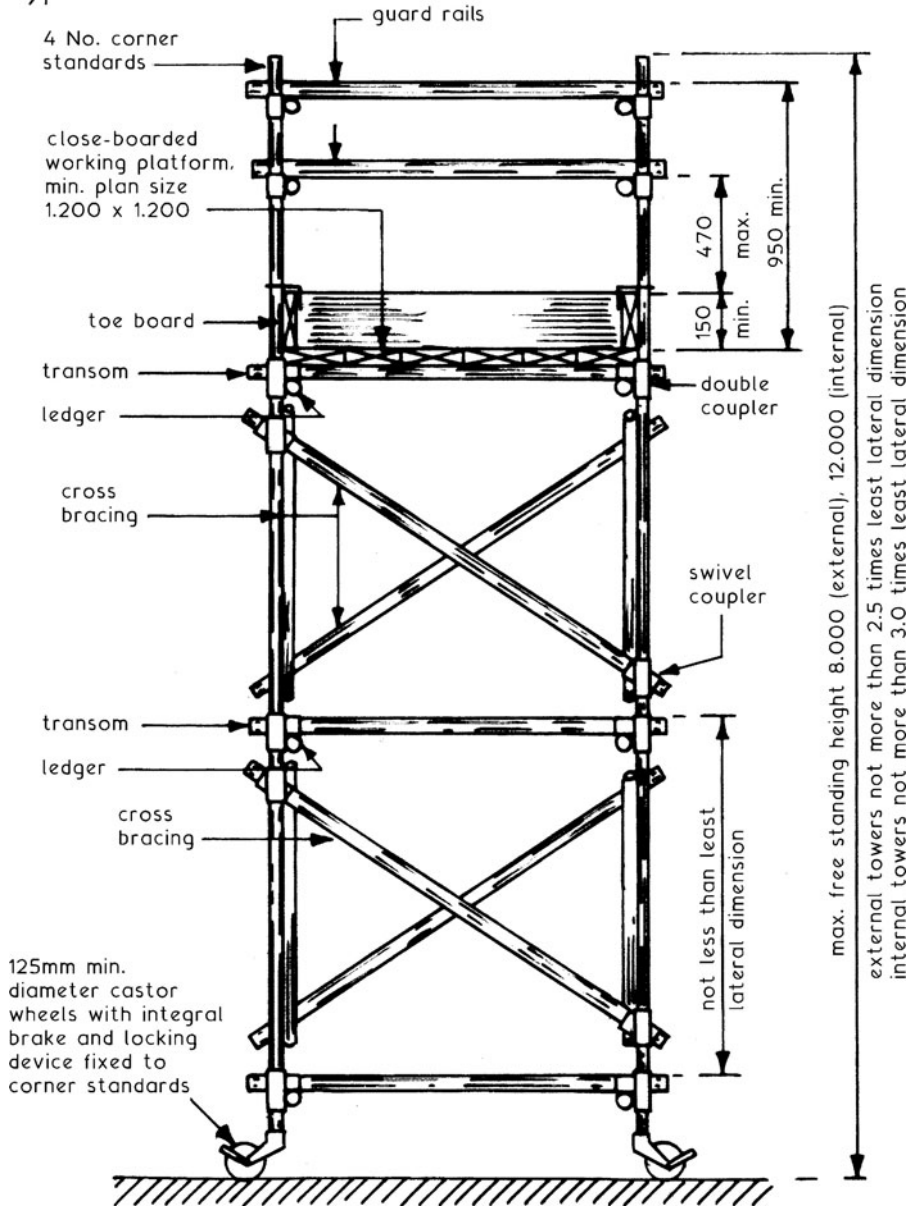

Ladder Access:  
 Inclined within the tower to hinged access door in platform.  
 Secured to tower so as not to foul the ground.  
 Lowest rung max. 400mm above the ground.

# Tubular Scaffolding

## Some basic fittings ~

Swivel coupler

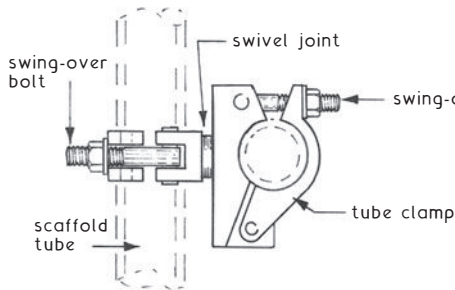

Double coupler

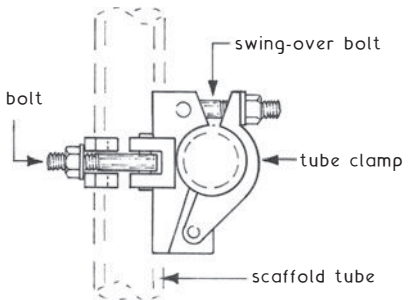

Wrapover putlog coupler

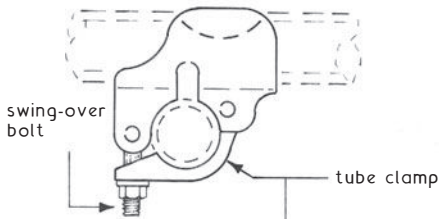

Putlog end

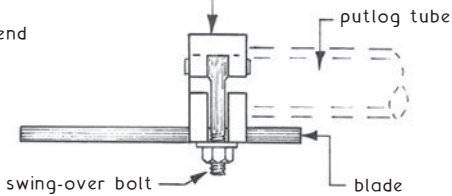

Base plate

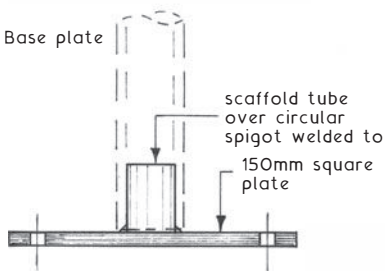

Split joint pin

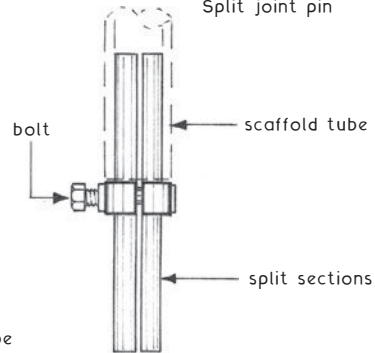

Reveal pin

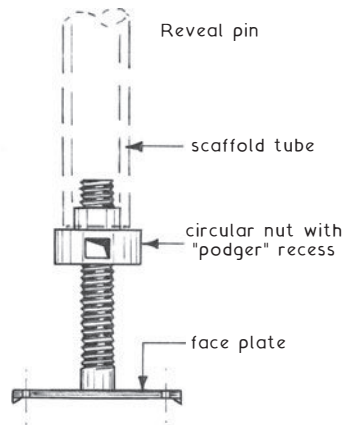

Patent Scaffolding ~ these are systems based on an independent scaffold format in which the members are connected together using an integral locking device instead of conventional clips and couplers used with traditional tubular scaffolding. They have the advantages of being easy to assemble and take down using semi-skilled labour and should automatically comply with the requirements set out in the Work at Height Regulations 2005. Generally cross bracing is not required with these systems but façade bracing can be fitted if necessary. Although simple in concept patent systems of scaffolding can lack the flexibility of traditional tubular scaffolds in complex layout situations.

Typical Example ~

1.500 or 2.500 long high tensile steel ledger

1.000; 2.000 or 3.000 long high tensile steel standard

1.270 long high tensile steel transom

connecting pockets to receive blade ends of ledgers and transom welded to standard at 500mm centres

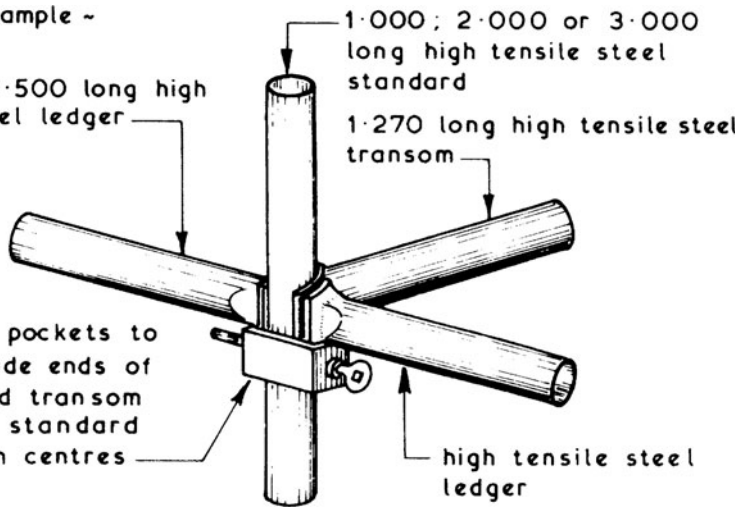

MAIN COMPONENTS

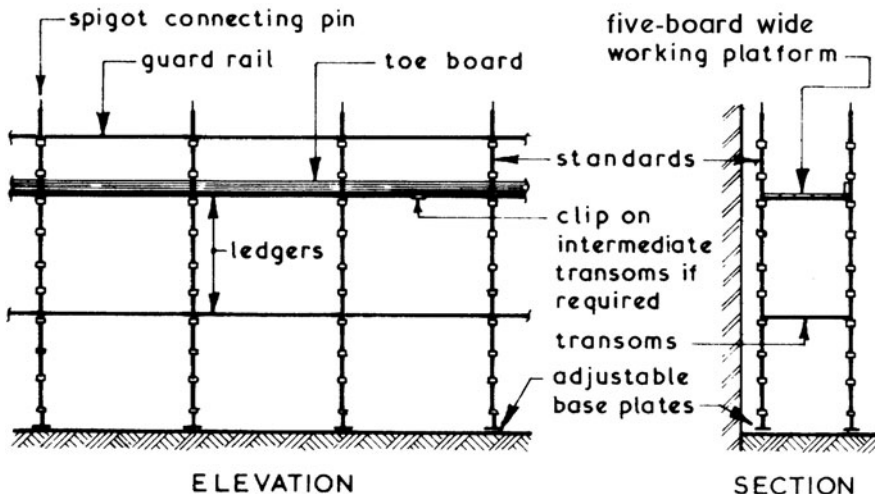



## Scaffolding Systems

Scaffolding Systems ~ these are temporary stagings to provide safe access to and egress from a working platform. The traditional putlog and independent scaffolds have been covered on pages 172 to 176 inclusive. The minimum design, safety, inspection and performance requirements applicable to traditional scaffolds apply equally to special scaffolds. Special scaffolds are designed to fulfil a specific function or to provide access to areas where it is not possible and/or economic to use traditional formats. They can be constructed from standard tubes or patent systems; the latter complying with most regulation requirements are easy and quick to assemble but lack the complete flexibility of the traditional tubular scaffolds.

Birdcage Scaffolds ~ these are a form of independent scaffold normally used for internal work in large buildings such as public halls and churches to provide access to ceilings and soffits for light maintenance work like painting and cleaning. They consist of parallel rows of standards connected by leaders in both directions, the whole arrangement being firmly braced in all directions. The whole birdcage scaffold assembly is designed to support a single working platform which should be double planked or underlined with polythene or similar sheeting as a means of restricting the amount of dust reaching the floor level.

Slung Scaffolds ~ these are a form of scaffold which is suspended from the main structure by means of wire ropes or steel chains and is not provided with a means of being raised or lowered. Each working platform of a slung scaffold consists of a supporting framework of ledgers and transoms which should not create a plan size in excess of  $2.500 \times 2.500$  and be held in position by not less than six evenly spaced wire ropes or steel chains securely anchored at both ends. The working platform should be double planked or underlined with polythene or similar sheeting to restrict the amount of dust reaching the floor level. Slung scaffolds are an alternative to birdcage scaffolds and although more difficult to erect have the advantage of leaving a clear space beneath the working platform which makes them suitable for cinemas, theatres and high-ceilinged banking halls.

Suspended Scaffolds ~ these consist of a working platform in the form of a cradle which is suspended from cantilever beams or outriggers from the roof of a tall building to give access to the façade for carrying out light maintenance work and cleaning activities. The cradles can have manual or power control and be in single units or grouped together to form a continuous working platform. If grouped together they are connected to one another at their abutment ends with hinges to form a gap of not more than 25mm wide. Many high-rise buildings have a permanent cradle system installed at roof level and this is recommended for all buildings over 30·000 high.

Typical Example ~

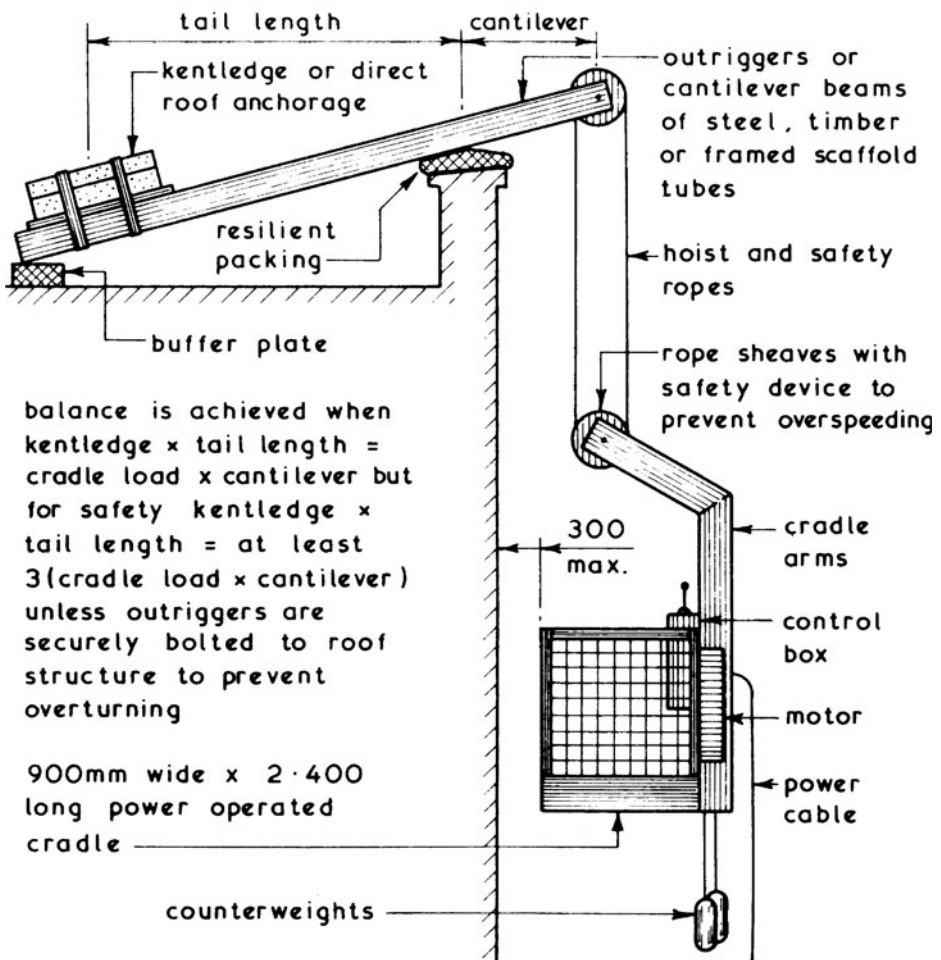

# Scaffolding Systems

Cantilever Scaffolds ~ these are a form of independent tied scaffold erected on cantilever beams and used where it is impracticable, undesirable or uneconomic to use a traditional scaffold raised from ground level. The assembly of a cantilever scaffold requires special skills and should therefore always be carried out by trained and experienced personnel.

Typical Example ~

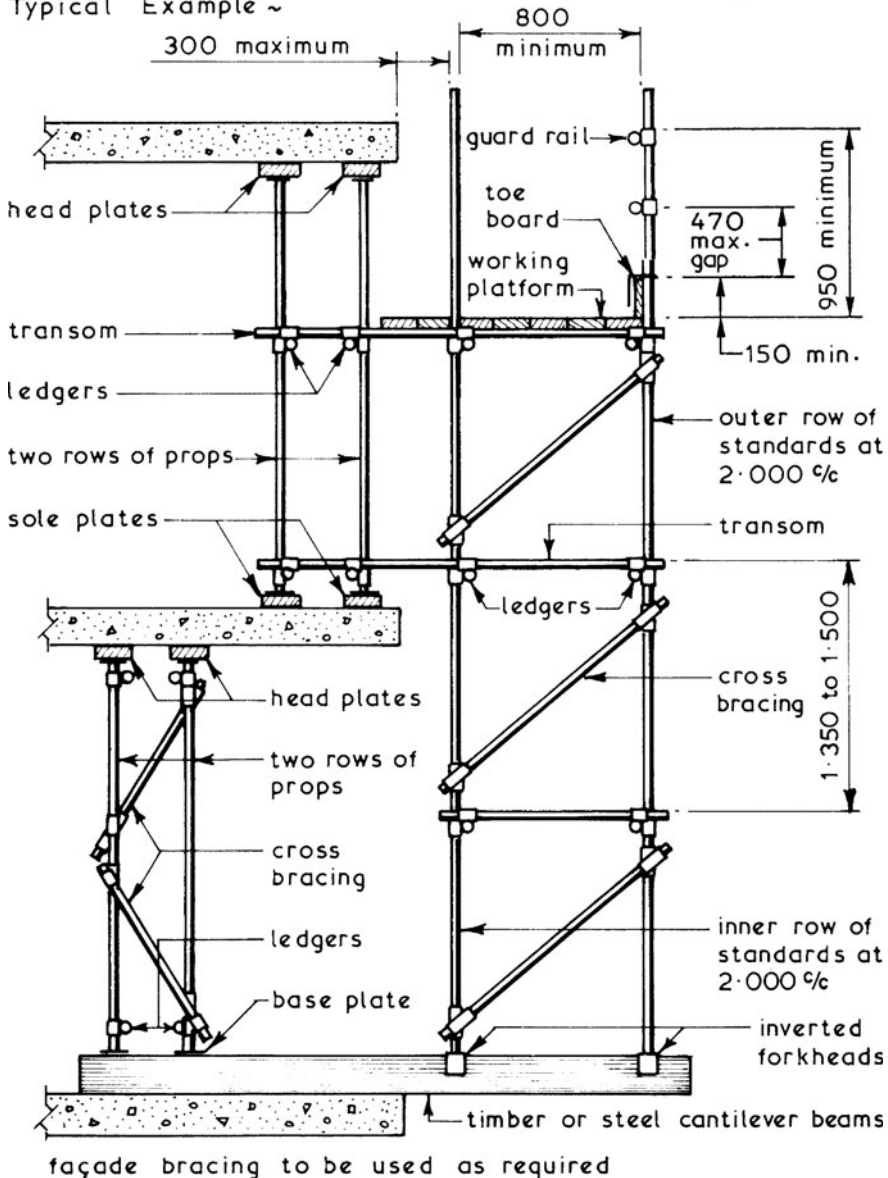

Truss-out Scaffold ~ this is a form of independent tied scaffold used where it is impracticable, undesirable or uneconomic to build a scaffold from ground level. The supporting scaffold structure is known as the truss-out. The assembly of this form of scaffold requires special skills and should therefore be carried out by trained and experienced personnel.

Typical Example ~

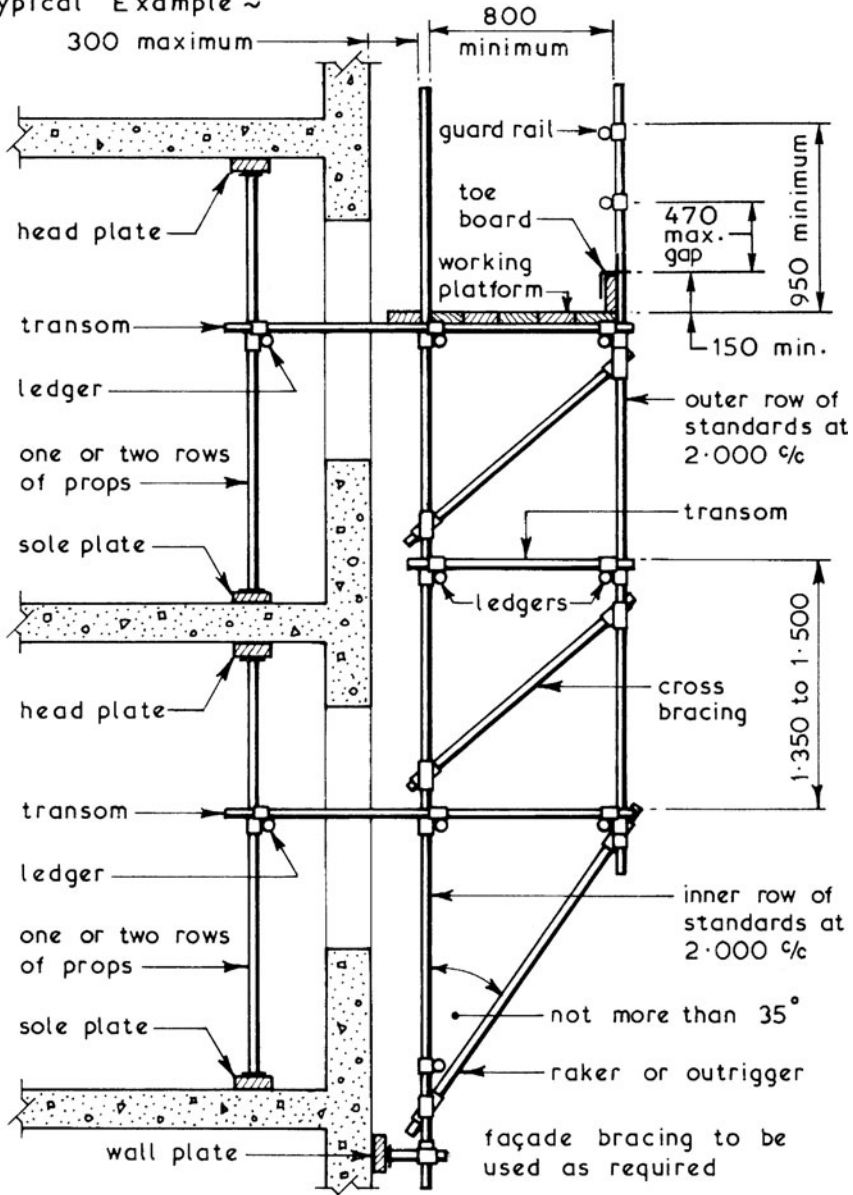

## Scaffolding Systems

Gantries ~ these are elevated platforms used when the building being maintained or under construction is adjacent to a public footpath. A gantry over a footpath can be used for storage of materials, housing units of accommodation and supporting an independent scaffold. Local authority permission will be required before a gantry can be erected and they have the power to set out the conditions regarding minimum sizes to be used for public walkways and lighting requirements. It may also be necessary to comply with police restrictions regarding the loading and unloading of vehicles at the gantry position. A gantry can be constructed of any suitable structural material and may need to be structurally designed to meet all the necessary safety requirements.

### Typical Example ~

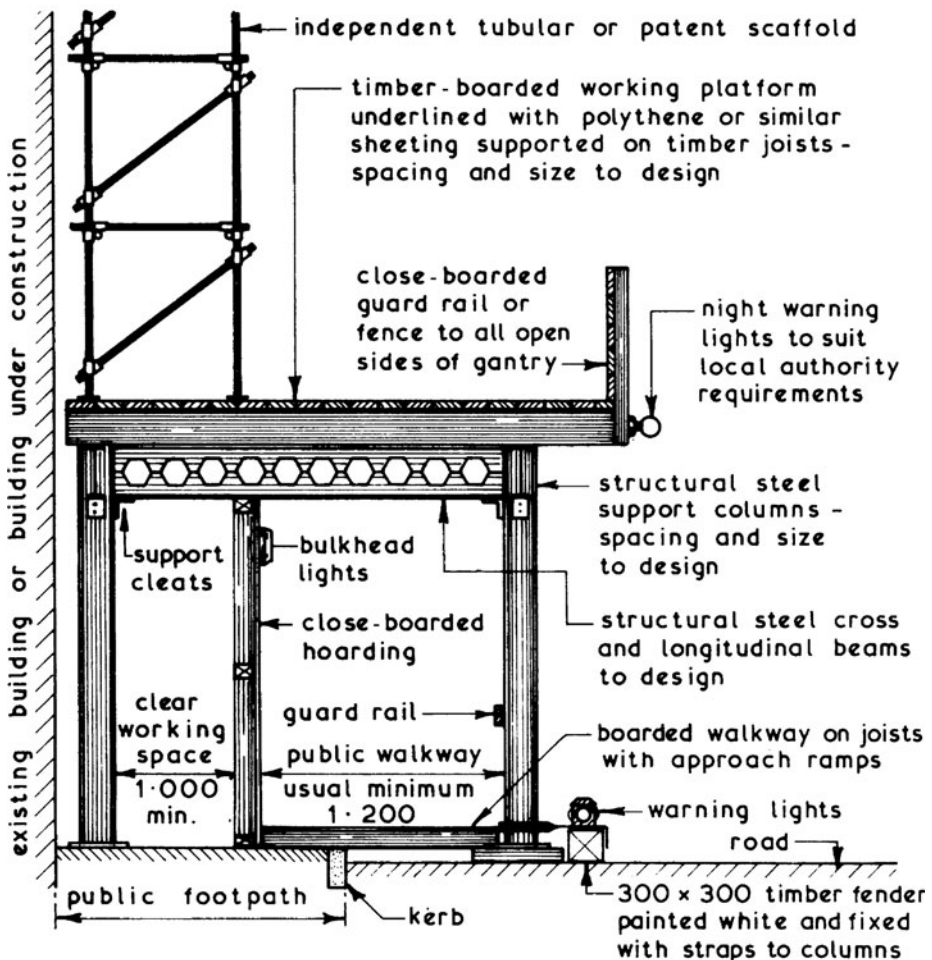

### Principle Considerations ~

- Structural stability and integrity.
- Safety of personnel using a scaffold and for those in the vicinity.

### Relevant Factors ~

- Simple configurations of putlog and independent scaffold, otherwise known as *basic systems* (see National Access and Scaffolding Confederation [NASC] technical guidance) do not require specific design calculations. Structural calculations are to be prepared by an appropriately qualified person for other applications.
- Assembly, alterations and dismantling to be undertaken in accordance with NASC technical guidance or system scaffolding manufacturer's instructions.
- Scaffold erectors to be competence qualified, e.g. having attended a Construction Industry Scaffolders Registration Scheme (CISRS) course and be in possession of a *scaffolder's card*. Trainees to be supervised by a competent qualified person, e.g. foreman scaffolder.
- Non-basic scaffolds should have a sequence and methodology for assembly and dismantling, plus further guidance for any anticipated alterations included with the design information. Any unforeseen alterations should receive specific design consideration.
- On completion, the scaffold supplier should provide a 'handover certificate' endorsed with references to design drawings and calculations. Any limitations of use, with particular mention of platform safe working loads, to be documented.
- Completed scaffolds to be inspected by a competent person, i.e. suitably qualified by experience and training. The latter assessed by the CISRS or by certificated attendance on a system scaffold manufacturer's course. This does not apply to basic systems mentioned in the first bullet point. These can be approved by a person of sufficient site experience such as a site manager.
- Inspection reports to be undertaken daily before work commences, after adverse weather and when alterations, modifications or additions are made. Any defects noted and corrective action taken.
- Incomplete scaffolds should be suitably signed for non-access. Physical barriers to be in place during assembly and dismantling.
- Inspection records to be documented and filed. These to include location and description of the scaffold, time and date of inspection, result of inspection and any actions taken. The report to be authorised by signature and endorsed with the inspector's job title.

# Shoring

Shoring ~ this is a form of temporary support which can be given to existing buildings with the primary function of providing the necessary precautions to avoid damage to any person or property from collapse of the supported structure.

Shoring Systems ~ there are three basic systems of shoring which can be used separately or in combination with one another to provide the support(s), namely:

1. Dead Shoring - used primarily to carry vertical loadings.
2. Raking Shoring - used to support a combination of vertical and horizontal loadings.
3. Flying Shoring - an alternative to raking shoring to give a clear working space at ground level.

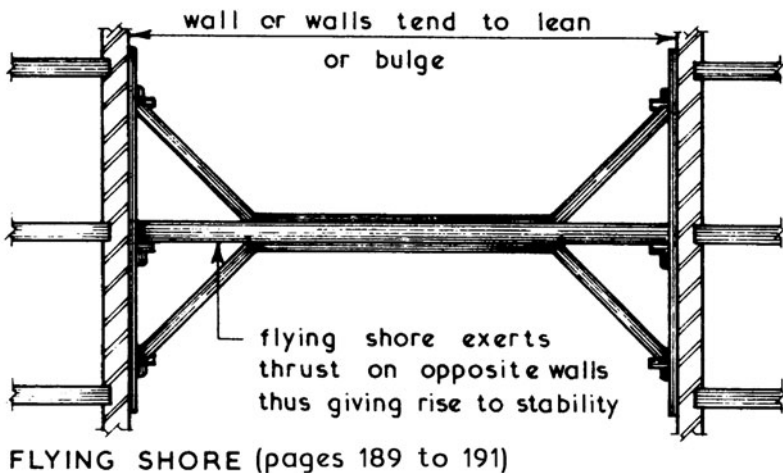
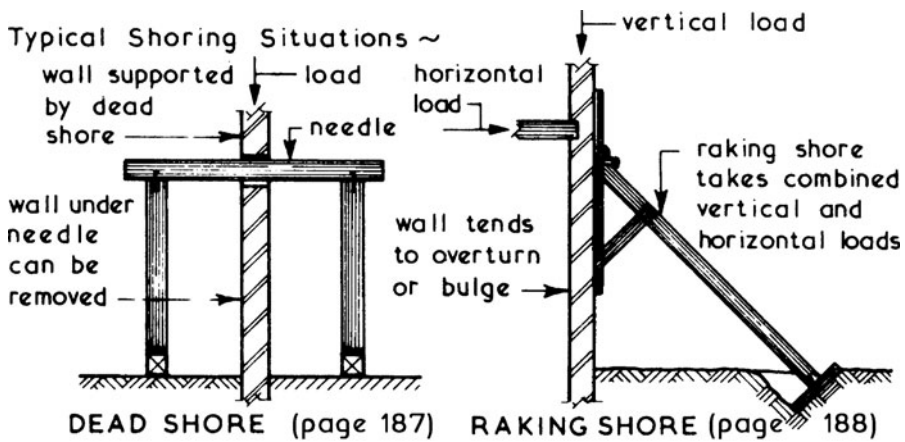

Dead Shores ~ these shores should be placed at approximately 2.000 c/c and positioned under the piers between the windows, any windows in the vicinity of the shores being strutted to prevent distortion of the openings. A survey should be carried out to establish the location of any underground services so that they can be protected as necessary. The sizes shown in the detail below are typical; actual sizes should be obtained from tables or calculated from first principles. Any suitable structural material such as steel can be substituted for the timber members shown.

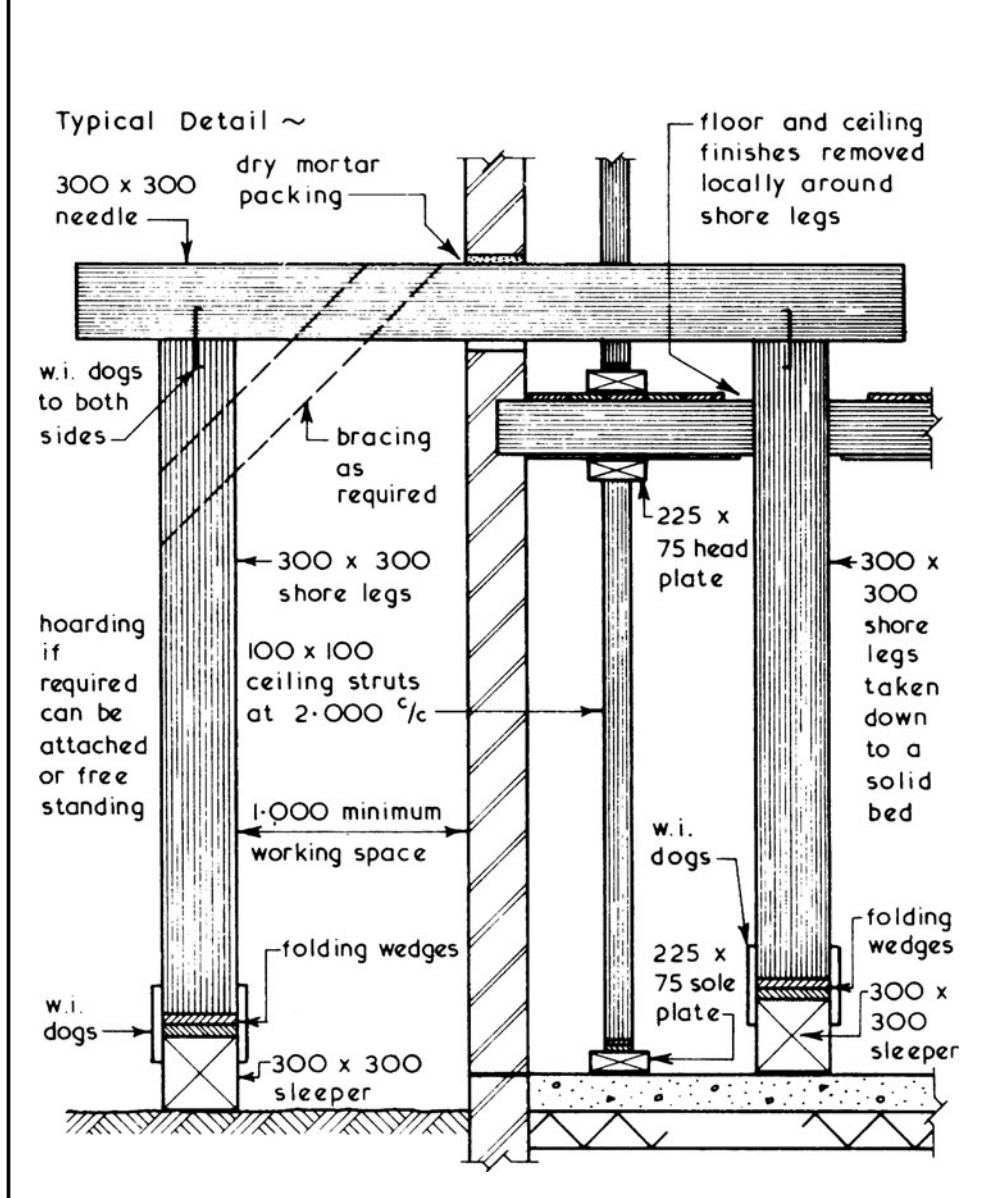



# Shoring

Raking Shoring ~ these are placed at 3-000 to 4-500 c/c and can be of single, double, triple or multiple raker format. Suitable materials are timber, structural steel and framed tubular scaffolding.

Typical Multiple Raking Shore Detail ~

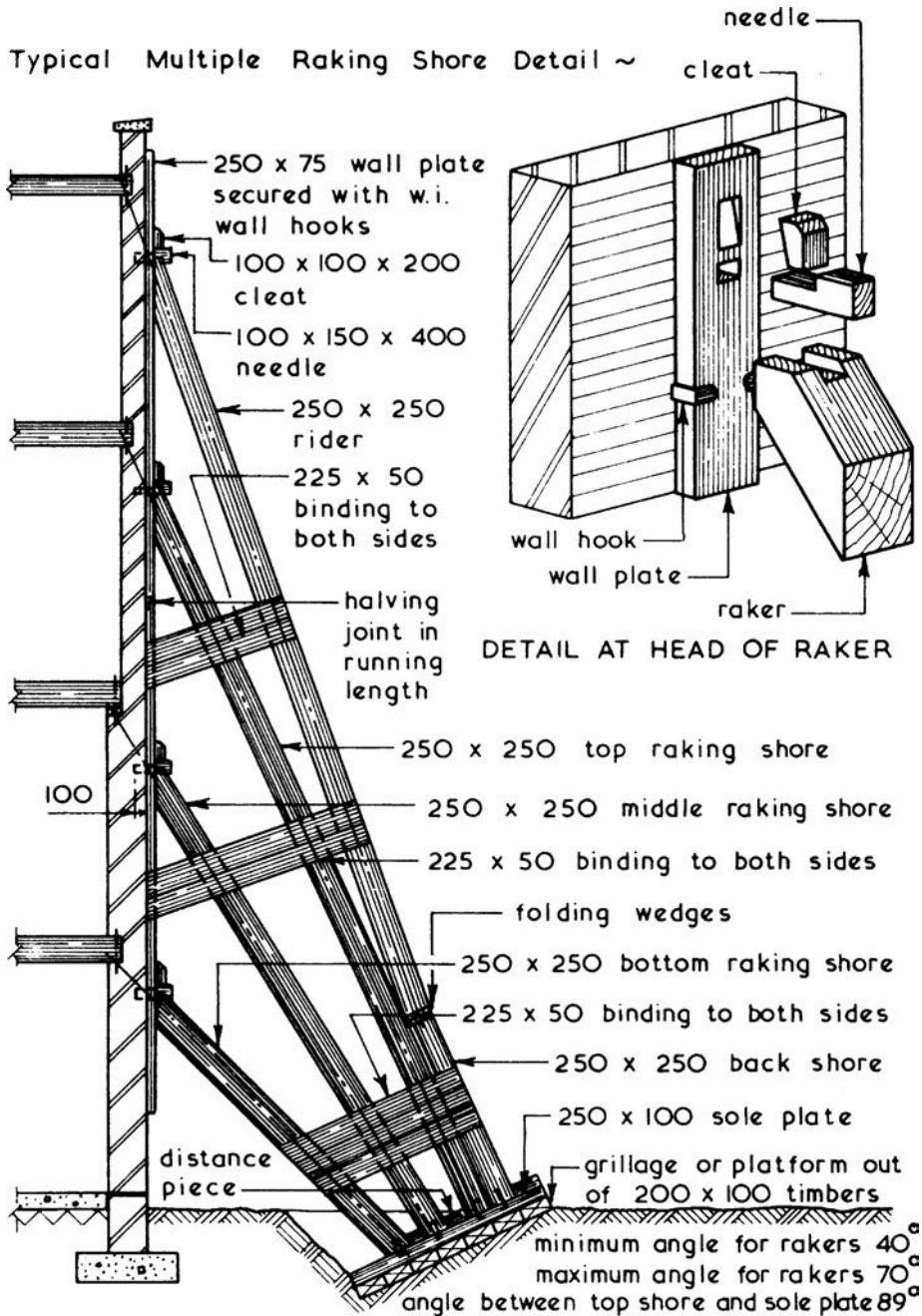



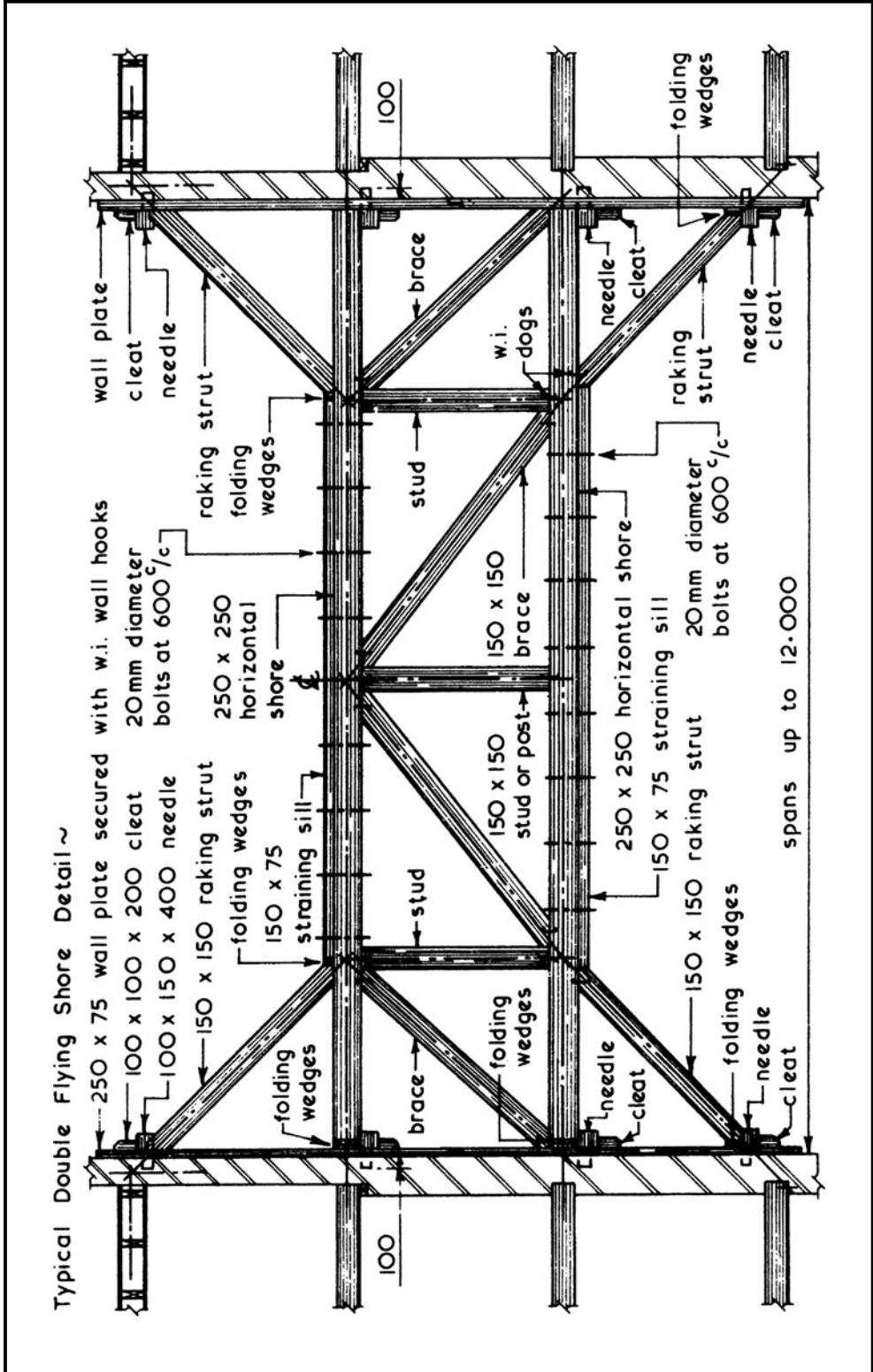

Unsymmetrical Flying Shores ~ arrangements of flying shores for unsymmetrical situations can be devised if the basic principles for symmetrical shores is applied (see page 189). In some cases the arrangement will consist of a combination of both raking and flying shore principles.

Typical Examples ~

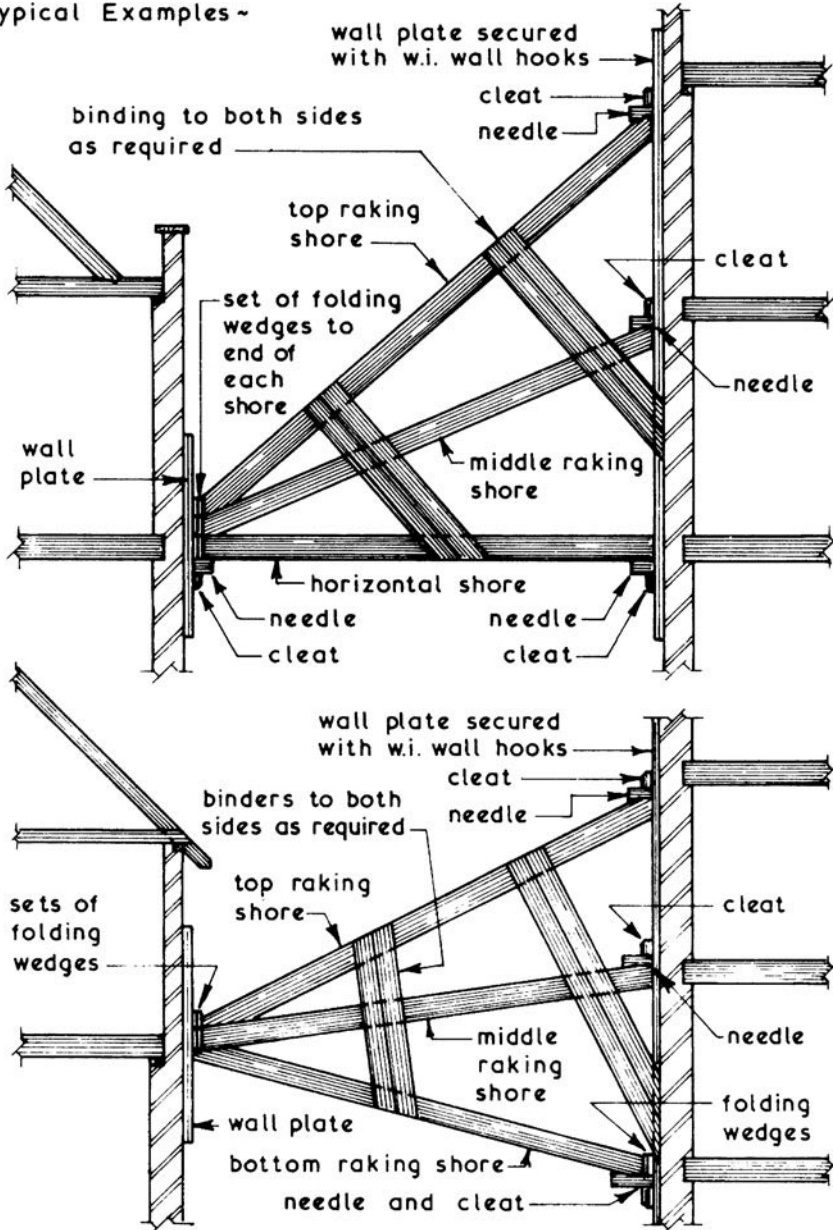

# Determination of Temporary Support Members

Temporary Support Determination ~ the basic sizing of most temporary supports follows the principles of elementary structural design. Readers with this basic knowledge should be able to calculate such support members which are required, particularly those used in the context of the maintenance and adaptation of buildings such as a dead shoring system.

## Typical Example ~

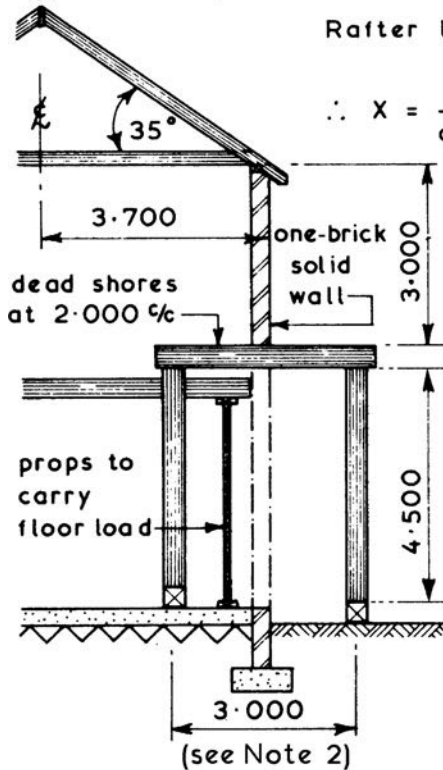

$$\text{Rafter length: } \cos 35^\circ = \frac{3.7}{X}$$

$$\therefore X = \frac{3.7}{\cos 35^\circ} = \frac{3.7}{0.8192} = 4.520$$

### Loadings:

Roof ~	kg/m <sup>2</sup>
tiles	71.0
battens	3.4
felt	2.0
rafters	7.5
	<hr/>
	83.9

say 84.0 kg/m<sup>2</sup>

Ceiling ~	kg/m <sup>2</sup>
joists	7.5
finishes	15.0
	<hr/>
	22.5

say 23.0 kg/m<sup>2</sup>

Wall ~	kg/m <sup>2</sup>
brickwork	490.0
plaster finish	6.8
	<hr/>
	496.8

say 500.0 kg/m<sup>2</sup>

$$\text{Weight of roof per metre run of wall} = 84 \times 4.52 = 379.68$$

$$\text{Weight of ceiling per metre run of wall} = 23 \times 3.70 = 85.10$$

$$\text{Weight of wall per metre run of wall} = 500 \times 3.00 = 1500.00$$

$$\text{Total weight of wall per metre run} = 1964.78$$

$$\text{Total weight supported by needle} = 1964.78 \times \text{shore centres}$$

$$= 1964.78 \times 2.000$$

$$= 3929.56 \text{ kg}$$

$$\text{say } 3930 \text{ kg}$$

For design calculations see pages 193 to 194.

Note 1: Typical weights of building materials, pages 38 to 39.

Note 2: Effective span (3.000 c/c) is often preferred to clear span for design of flexural members.

Design calculations reference previous page.

Timber strength class C22, See page 142 for data.

Needle Design:

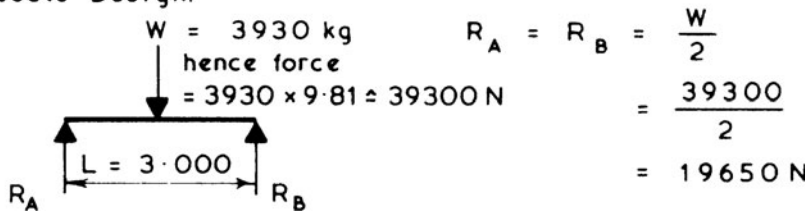

$$BM = \frac{WL}{4} = \frac{39300 \times 3000}{4} = 29475000 \text{ Nmm}$$

$$MR = \text{stress} \times \text{section modulus} = fZ = f \frac{bd^2}{6}$$

assume  $b = 300 \text{ mm}$  and  $f = 6.8 \text{ N/mm}^2$

$$\text{then } 29475000 = \frac{6.8 \times 300 \times d^2}{6}$$

$$d = \sqrt{\frac{29475000 \times 6}{6.8 \times 300}} = 294 \text{ mm}$$

use  $300 \times 300$  timber section or 2 No.  $150 \times 300$  sections bolted together with timber connectors.

Props to Needle Design:

$$\text{area} = \frac{\text{load}}{\text{stress}} = \frac{19650}{7.5} = 2620 \text{ mm}^2$$

$$\therefore \text{minimum timber size} = \sqrt{2620} = 52 \times 52 \text{ mm}$$

check slenderness ratio:

$$\text{slenderness ratio} = \frac{\text{effective length}}{\text{breadth}} = \frac{4500}{52} = 86.5$$

the  $52 \times 52 \text{ mm}$  section is impractically small with a very high slenderness ratio, therefore a more stable section of say  $300 \times 225 \text{ mm}$  would be selected giving a slenderness ratio of  $4500/225 = 20$  (stability check, next page)

Check crushing at point of loading on needle:

$$\text{wall loading on needle} = 3930 \text{ kg} = 39300 \text{ N} = 39.3 \text{ kN}$$

$$\begin{aligned} \text{area of contact} &= \text{width of wall} \times \text{width of needle} \\ &= 215 \times 300 = 64500 \text{ mm}^2 \end{aligned}$$

safe compressive stress perpendicular to grain =  $2.3 \text{ N/mm}^2$

$$\therefore \text{safe load} = \frac{64500 \times 2.3}{1000} = 148.3 \text{ kN which is } > 39.3 \text{ kN}$$

## Design of Temporary Vertical Supports and Struts

Stability check using the example from previous page ~

Timber of strength classification C22 (see page 142):

Modulus of elasticity, 6500N/mm<sup>2</sup> minimum.

Grade stress in compression parallel to the grain, 7.5N/mm<sup>2</sup>.

Grade stress ratio =  $6500 \div 7.5 = 867$

The grade stress and slenderness ratios are used to provide a modification factor for the compression parallel to the grain. The following table shows some of these factors:

	Effective length/breadth of section (slenderness ratio)								
	3	6	12	18	24	30	36	42	48
Grade stress ratio									
400	0.95	0.90	0.74	0.51	0.34	0.23	0.17	0.11	0.10
600	0.95	0.90	0.77	0.58	0.41	0.29	0.21	0.16	0.13
800	0.95	0.90	0.78	0.63	0.48	0.36	0.26	0.21	0.16
1000	0.95	0.90	0.79	0.66	0.52	0.41	0.30	0.24	0.19
1200	0.95	0.90	0.80	0.68	0.56	0.44	0.34	0.27	0.22
1400	0.95	0.90	0.80	0.69	0.58	0.47	0.37	0.30	0.24
1600	0.95	0.90	0.81	0.70	0.60	0.49	0.40	0.32	0.27
1800	0.95	0.90	0.81	0.71	0.61	0.51	0.42	0.34	0.29
2000	0.95	0.90	0.81	0.71	0.62	0.52	0.44	0.36	0.31

By interpolation, a grade stress of 867 and a slenderness ratio of 20 indicates that 7.5N/mm<sup>2</sup> is multiplied by 0.57.

Applied stress should be  $\leq 7.5 \times 0.57 = 4.275$  N/mm<sup>2</sup>.

Applied stress = axial load  $\div$  prop section area  
 $= 19650\text{N} \div (300 \times 225\text{mm}) = 0.291$  N/mm<sup>2</sup>

0.291N/mm<sup>2</sup> is well within the allowable stress of 4.275 N/mm<sup>2</sup>, therefore 300 × 225mm props are satisfactory.

Ref. BS EN 1995-1-1: Design of timber structures. General. Common rules and rules for buildings.

Town and Country Planning Act ~ demolition is generally not regarded as development, but planning permission will be required if the site is to have a change of use. Attitudes to demolition can vary between local planning authorities and consultation should be sought.

Planning (Listed Buildings and Conservation Areas) Act ~ listed buildings and those in conservation areas will require local authority approval for any alterations. Consent for change may be limited to partial demolition, particularly where it is necessary to preserve a building frontage for historic reasons. See the arrangements for temporary shoring on the preceding pages.

Building Act ~ intention to demolish a building requires six weeks' written notice of intent. The next page shows the typical outline of a standard form for submission to the building control department of the local authority, along with location plans. Notice must also be given to utilities providers and adjoining/adjacent building owners, particularly where party walls are involved. Small buildings of volumes less than 50m<sup>3</sup> are generally exempt. Within six weeks of the notice being submitted, the local authority will specify their requirements for shoring, protection of adjacent buildings, debris disposal and general safety requirements under the HSE.

Public Health Act ~ the local authority can issue a demolition enforcement order to a building owner, where a building is considered to be insecure, a danger to the general public and detrimental to amenities.

Highways Act ~ concerns the protection of the general public using a thoroughfare in or near to an area affected by demolition work. The building owner and demolition contractor are required to ensure that debris and other materials are not deposited in the street unless in a suitable receptacle (skip) and the local authority highways department and police are in agreement with its location. Temporary road-works require protective fencing and site hoardings must be robust and secure. All supplementary provisions such as hoardings and skips may also require adequate illumination. Provision must be made for immediate removal of poisonous and hazardous waste.



Anytown Borough Council  
Building Control Section  
Anytown  
UK

Tel: .....  
Fax: .....  
Email: .....

**NOTICE TO LOCAL AUTHORITY TO CARRY OUT DEMOLITION WORKS**

**THE BUILDING ACT 1984 – SECTION 80**

It is my intention to commence demolition of:

.....  
.....  
.....

As shown on the attached site plan, on the ..... (date)

This date is at least six weeks from the date of this notice. Under section 81 of the Building Act, I anticipate your notification within six weeks.

Copies of this notice have been sent to:

- The occupants/owners of any/all buildings adjacent to the proposed demolition.
- The public services/utilities supply companies.

Signed ..... Date .....

Company name and address .....

.....  
.....

Demolition ~ skilled and potentially dangerous work that should only be undertaken by experienced contractors.

Types of demolition ~ partial or complete removal. Partial is less dynamic than complete removal, requiring temporary support to the remaining structure. This may involve window strutting, floor props and shoring. The execution of work is likely to be limited to manual handling with minimal use of powered equipment.

Preliminaries ~ a detailed survey should include:

- an assessment of condition of the structure and the impact of removing parts on the remainder.
- the effect demolition will have on adjacent properties.
- photographic records, particularly of any noticeable defects on adjacent buildings.
- neighbourhood impact, i.e. disruption, disturbance, protection.
- the need for hoardings, see pages 113 to 117.
- potential for salvaging/recycling/reuse of materials.
- extent of basements and tunnels.
- services - need to terminate and protect for future reconnections.
- means for selective removal of hazardous materials.

Insurance ~ general builders are unlikely to find demolition cover in their standard policies. All risks indemnity should be considered to cover claims from site personnel and others accessing the site. Additional third party cover will be required for claims for loss or damage to other property, occupied areas, business, utilities, private and public roads.

Salvage ~ salvaged materials and components can be valuable: bricks, tiles, slates, steel sections and timber are all marketable. Architectural features such as fireplaces and stairs will command a good price. Reclamation costs will be balanced against the financial gain.

Asbestos ~ this banned material has been used in a variety of applications including pipe insulation, fire protection, sheet claddings, linings and roofing. Samples should be taken for laboratory analysis and if necessary, specialist contractors engaged to remove material before demolition commences.

## Demolition – Methods

Generally ~ the reverse order of construction to gradually reduce the height. Where space is not confined, overturning or explosives may be considered.

Piecemeal ~ use of handheld equipment such as pneumatic breakers, oxy-acetylene cutters, picks and hammers. Care should be taken when salvaging materials and other reusable components. Chutes should be used to direct debris to a suitable place of collection (see page 220).

Pusher Arm ~ usually attached to a long reach articulated boom fitted to a tracked chassis. Hydraulic movement is controlled from a robust cab structure mounted above the tracks.

Wrecking Ball ~ largely confined to history, as even with safety features such as anti-spin devices, limited control over a heavy weight swinging and slewing from a crane jib will be considered unsafe in many situations.

Impact Hammer ~ otherwise known as a 'pecker'. Basically a large chisel operated by pneumatic power and fitted to the end of an articulated boom on a tracked chassis.

Nibbler ~ a hydraulically operated grip fitted as above that can be rotated to break brittle materials such as concrete.

Overturning ~ steel wire ropes of at least 38mm diameter attached at high level and to an anchored winch or heavy vehicle. May be considered where controlled collapse is encouraged by initial removal of key elements of structure, typical of steel framed buildings. Alternative methods should be given preference.

Explosives ~ demolition is specialised work and the use of explosives in demolition is a further specialised practice limited to very few licensed operators. Charges are set to fire in a sequence that weakens the building to a controlled internal collapse.

Some additional references ~

BS 6187: Code of practice for full and partial demolition.

The Construction (Design and Management) Regulations.

The Management of Health and Safety at Work Regulations.

Concept ~ to reduce waste by designing for deconstruction.

Linear (wasteful, non-sustainable) process ~

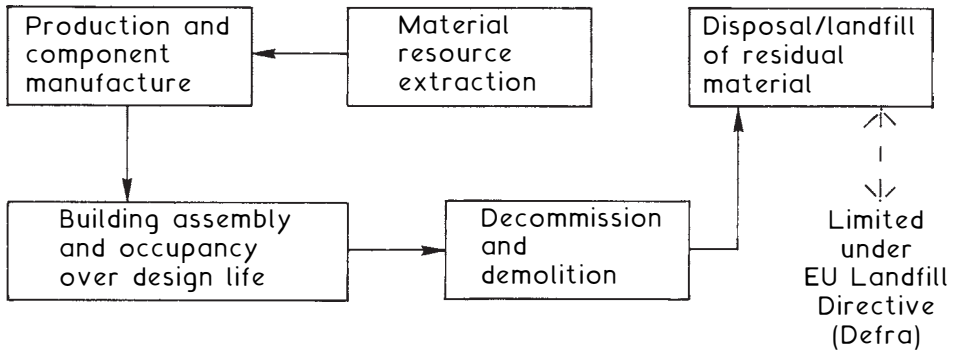

Closed-loop (near zero waste, sustainable) process ~

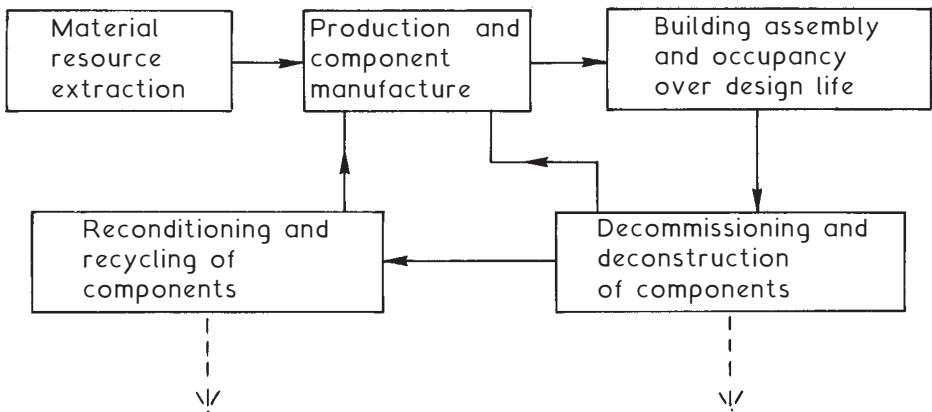

Reusable examples may include:

- Recycled concrete aggregate (RCA) and broken masonry for hardcore, backfill, landscaping, etc.
- Recovered: structural timber joists and joinery. architectural components/features. slates and tiles. structural steel standard sections.

*This page intentionally left blank*

## 3 BUILDERS PLANT

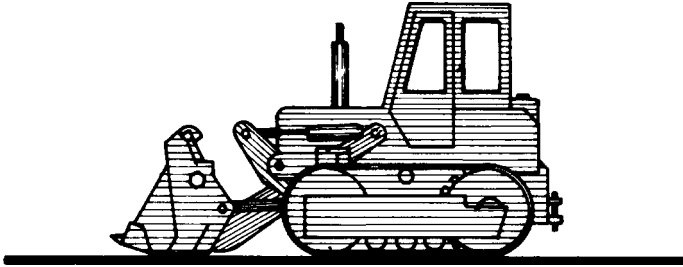

GENERAL CONSIDERATIONS

BULLDOZERS

SCRAPERS

GRADERS

TRACTOR SHOVELS

EXCAVATORS

TRANSPORT VEHICLES

HOISTS

RUBBLE CHUTES AND SKIPS

CRANES

CONCRETING PLANT

## Builders Plant

General Considerations ~ items of builders plant ranging from small handheld power tools to larger pieces of plant such as mechanical excavators and tower cranes can be considered for use for one or more of the following reasons:

1. Increased production.
2. Reduction in overall construction costs.
3. Carry out activities which cannot be carried out by the traditional manual methods in the context of economics.
4. Eliminate heavy manual work, thus reducing fatigue and as a consequence increasing productivity.
5. Replacing labour where there is a shortage of personnel with the necessary skills.
6. Maintain the high standards required, particularly in the context of structural engineering works.

Economic Considerations ~ the introduction of plant does not always result in economic savings since extra temporary site works such as road-works, hardstandings, foundations and anchorages may have to be provided at a cost which is in excess of the savings made by using the plant. The site layout and circulation may have to be planned around plant positions and movements rather than around personnel and material movements and accommodation. To be economic plant must be fully utilised and not left standing idle, since plant, whether hired or owned, will have to be paid for even if it is non-productive. Full utilisation of plant is usually considered to be in the region of 85% of on-site time, thus making an allowance for routine, daily and planned maintenance which needs to be carried out to avoid as far as practicable plant breakdowns which could disrupt the construction programme. Many pieces of plant work in conjunction with other items of plant such as excavators and their attendant haulage vehicles; therefore a correct balance of such plant items must be obtained to achieve an economic result.

Maintenance Considerations ~ on large contracts where a number of plant items are to be used it may be advantageous to employ a skilled mechanic to be on site to carry out all the necessary daily, preventive and planned maintenance tasks together with any running repairs which could be carried out on site.

Plant Costing ~ with the exception of small pieces of plant, which are usually purchased, items of plant can be bought or hired or where there are a number of similar items a combination of buying and hiring could be considered. The choice will be governed by economic factors and the possibility of using the plant on future sites, thus enabling the costs to be apportioned over several contracts.

Advantages of Hiring Plant:

1. Plant can be hired for short periods.
2. Repairs and replacements are usually the responsibility of the hire company.
3. Plant is returned to the hire company after use, thus relieving the building contractor of the problem of disposal or finding more work for the plant to justify its purchase or retention.
4. Plant can be hired with the operator, fuel and oil included in the hire rate.

Advantages of Buying Plant:

1. Plant availability is totally within the control of the contractor.
2. Hourly cost of plant is generally less than hired plant.
3. Owner has choice of costing method used.

Typical Costing Methods ~

1. Straight Line – simple method

Capital Cost = £ 100 000  
 Anticipated life = 5 years  
 Year's working = 1500 hrs  
 Resale or scrap value = £ 9 000  
 Annual depreciation ~  

$$= \frac{100\,000 - 9\,000}{5} = \text{£ } 18\,200$$
 Hourly depreciation ~  

$$= \frac{18\,200}{1\,500} = 12.13$$
 Add 2% insurance = 0.27  
 10% maintenance = 1.33  
 Hourly rate = £ 13.73

2. Interest on Capital Outlay – widely used more accurate method

Capital Cost	=	£ 100 000
C.I. on capital (8% for 5 yrs)	=	<u>46 930</u>
		146 930
Deduct resale value		<u>9 000</u>
		137 930
+ Insurance at 2%	=	2 000
+ Maintenance at 10%	=	<u>10 000</u>
		149 930

Hourly rate ~

$$= \frac{149\,930}{5 \times 1\,500} = \text{£ } 20.00$$

NB. add to hourly rate running costs.



## Builders Plant

Output and Cycle Times ~ all items of plant have optimum output and cycle times which can be used as a basis for estimating anticipated productivity taking into account the task involved, task efficiency of the machine, operator's efficiency and in the case of excavators the type of soil. Data for the factors to be taken into consideration can be obtained from timed observations, feedback information or published tables contained in manufacturer's literature or reliable textbooks.

Typical Example ~

Backacter with  $1\text{m}^3$  capacity bucket engaged in normal trench excavation in a clayey soil and discharging directly into an attendant haulage vehicle.

Optimum output	= 60 bucket loads per hour
Task efficiency factor	= 0.8 (from tables)
Operator efficiency factor	= 75% (typical figure)
∴ Anticipated output	= $60 \times 0.8 \times 0.75$
	= 36 bucket loads per hour
	= $36 \times 1 = 36 \text{ m}^3$ per hour

An allowance should be made for the bulking or swell of the solid material due to the introduction of air or voids during the excavation process

∴ Net output allowing for a 30% swell =  $36 - (36 \times 0.3)$   
= say  $25\text{m}^3$  per hr.

If the Bill of Quantities gives a total net excavation of  $950\text{m}^3$

time required =  $\frac{950}{25} = \underline{38 \text{ hours}}$

or assuming an 8-hour day–1/2 hour maintenance time in

days =  $\frac{38}{7.5} = \text{say } \underline{5 \text{ days}}$

Haulage vehicles required =  $1 + \frac{\text{round trip time of vehicle}}{\text{loading time of vehicle}}$

If round trip time = 30 min. and loading time = 10 min.

number of haulage vehicles required =  $1 + \frac{30}{10} = 4$

This gives a vehicle waiting overlap ensuring excavator is fully utilised which is economically desirable.

Bulldozers ~ these machines consist of a track or wheel mounted power unit with a mould blade at the front which is controlled by hydraulic rams. Many bulldozers have the capacity to adjust the mould blade to form an angledozer and the capacity to tilt the mould blade about a central swivel point. Some bulldozers can also be fitted with rear attachments such as rollers and scarifiers.

The main functions of a bulldozer are:

1. Shallow excavations up to 300 m deep either on level ground or sidehill cutting.
2. Clearance of shrubs and small trees.
3. Clearance of trees by using raised mould blade as a pusher arm.
4. Acting as a towing tractor.
5. Acting as a pusher to scraper machines (see next page).

NB. Bulldozers push earth in front of the mould blade with some side spillage whereas angledozers push and cast the spoil to one side of the mould blade.

## Typical Bulldozer Details ~

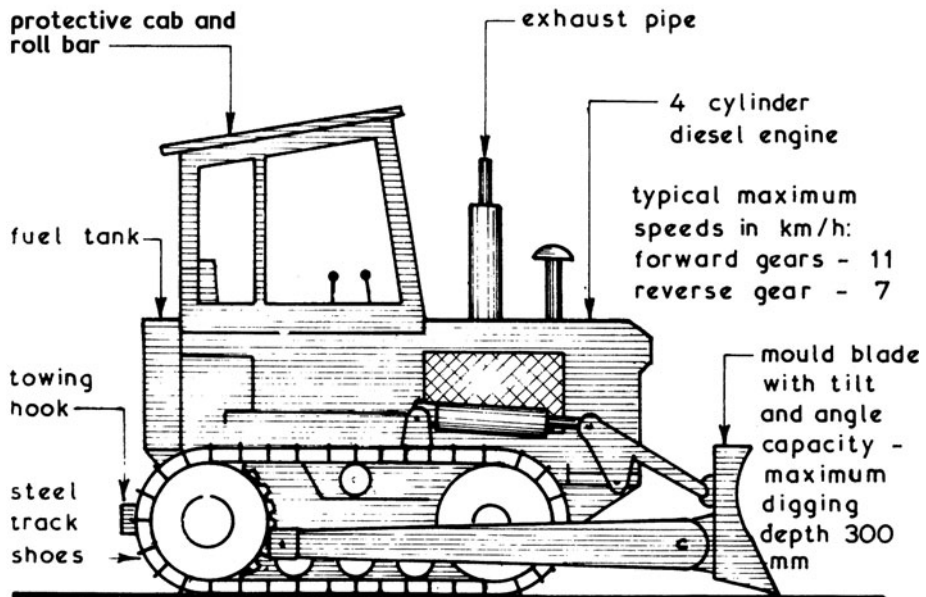

NB. Protective cab/roll bar to be fitted before use.

## Scrapers

Scrapers ~ these machines consist of a scraper bowl which is lowered to cut and collect soil where site stripping and levelling operations are required involving large volume of earth. When the scraper bowl is full the apron at the cutting edge is closed to retain the earth and the bowl is raised for travelling to the disposal area. On arrival the bowl is lowered, the apron opened and the spoil pushed out by the tailgate as the machine moves forward. Scrapers are available in three basic formats:

1. Towed Scrapers - these consist of a four-wheeled scraper bowl which is towed behind a power unit such as a crawler tractor. They tend to be slower than other forms of scraper but are useful for small capacities with haul distances up to 300.00.
2. Two axle Scrapers - these have a two-wheeled scraper bowl with an attached two-wheeled power unit. They are very manoeuvrable with a low rolling resistance and very good traction.
3. Three axle Scrapers - these consist of a two-wheeled scraper bowl which may have a rear engine to assist the four-wheeled traction engine which makes up the complement. Generally these machines have a greater capacity potential than their counterparts, are easier to control and have a faster cycle time.

To obtain maximum efficiency scrapers should operate downhill if possible, have smooth haul roads, hard surfaces broken up before scraping and be assisted over the last few metres by a pushing vehicle such as a bulldozer.

### Typical Scraper Details ~

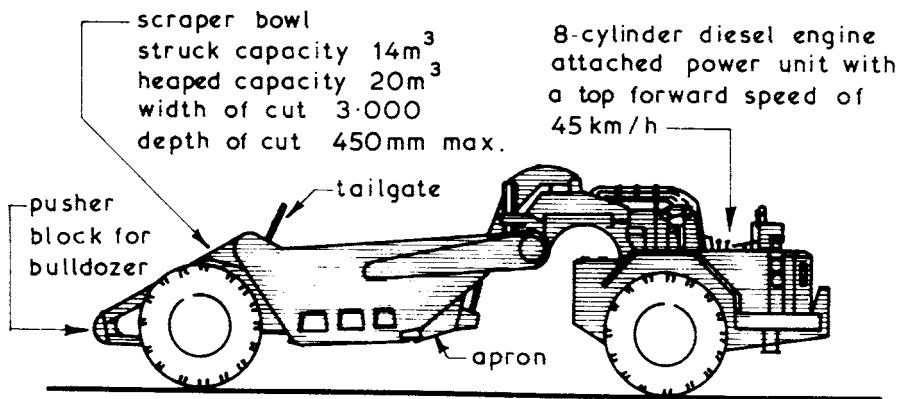

NB. Protective cab/roll bar to be fitted before use.

Graders ~ these machines are similar in concept to bulldozers in that they have a long, slender, adjustable mould blade, which is usually slung under the centre of the machine. A grader's main function is to finish or grade the upper surface of a large area usually as a follow up operation to scraping or bulldozing. They can produce a fine and accurate finish but do not have the power of a bulldozer; therefore they are not suitable for over-site excavation work. The mould blade can be adjusted in both the horizontal and vertical planes through an angle of  $300^\circ$  the latter enabling it to be used for grading sloping banks.

Two basic formats of grader are available:

1. Four Wheeled - all wheels are driven and steered which gives the machine the ability to offset and crab along its direction of travel.
2. Six Wheeled - this machine has four wheels in tandem drive at the rear and two front-tilting idler wheels, giving it the ability to counteract side thrust.

#### Typical Grader Details ~

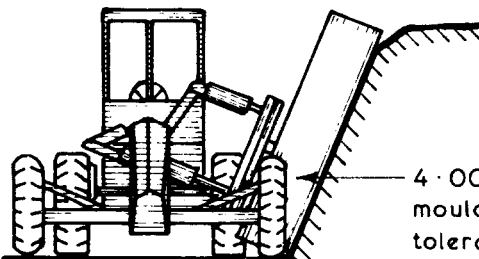
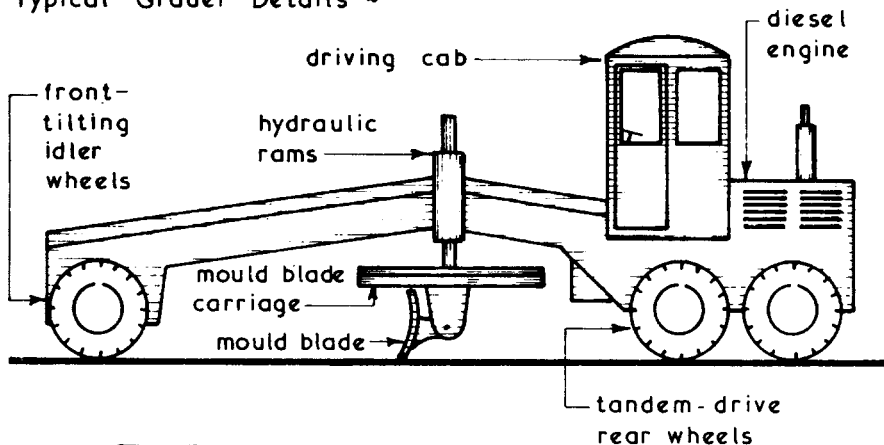

maximum speeds:  
finishing - 10 km/h  
banking - 6 km/h

4.000 wide x 600 mm high  
mould board with a finishing  
tolerance capacity of  $\pm 5$ mm

CUTTING, SHAPING AND  
GRADING BANKS

# Tractor Shovels

Tractor Shovels ~ these machines are sometimes called loaders or loader shovels and their primary function is to scoop up loose materials in the front-mounted bucket, elevate the bucket and manoeuvre into a position to deposit the loose material into an attendant transport vehicle. Tractor shovels are driven towards the pile of loose material with the bucket lowered; the speed and power of the machine will enable the bucket to be filled. Both tracked and wheeled versions are available, the tracked format being more suitable for wet and uneven ground conditions than the wheeled tractor shovel which has greater speed and manoeuvring capabilities. To increase their versatility tractor shovels can be fitted with a four-in-one bucket, enabling them to carry out bulldozing, excavating, clam lifting and loading activities.

## Typical Tractor Shovel Details ~

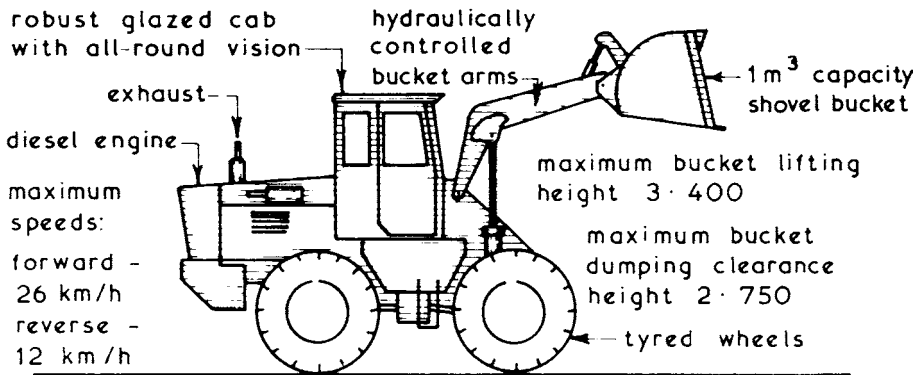
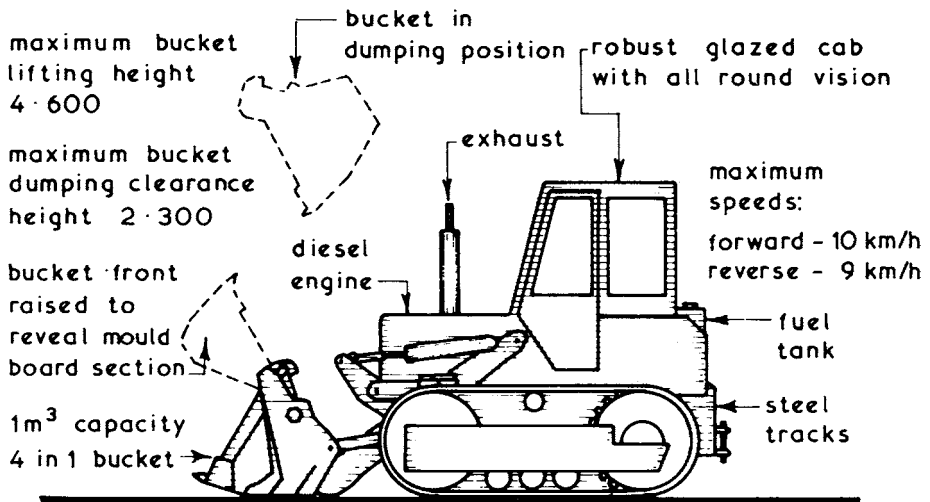

Excavating Machines ~ these are one of the major items of builders plant and are used primarily to excavate and load most types of soil. Excavating machines come in a wide variety of designs and sizes but all of them can be placed within one of three categories:

1. Universal Excavators - this category covers most forms of excavators all of which have a common factor: the power unit. The universal power unit is a tracked based machine with a slewing capacity of 360° and by altering the boom arrangement and bucket type different excavating functions can be obtained. These machines are selected for high output requirements and are rope controlled.
2. Purpose Designed Excavators - these are machines which have been designed specifically to carry out one mode of excavation and they usually have smaller bucket capacities than universal excavators; they are hydraulically controlled with a shorter cycle time.
3. Multi-purpose Excavators - these machines can perform several excavating functions having both front and rear attachments. They are designed to carry out small excavation operations of low output quickly and efficiently. Multi-purpose excavators can be obtained with a wheeled or tracked base and are ideally suited for a small building firm with low excavation plant utilisation requirements.

Skimmers ~ these excavators are rigged using a universal power unit for surface stripping and shallow excavation work up to 300 mm deep where a high degree of accuracy is required. They usually require attendant haulage vehicles to remove the spoil and need to be transported between sites on a low-loader. Because of their limitations and the alternative machines available they are seldom used today.

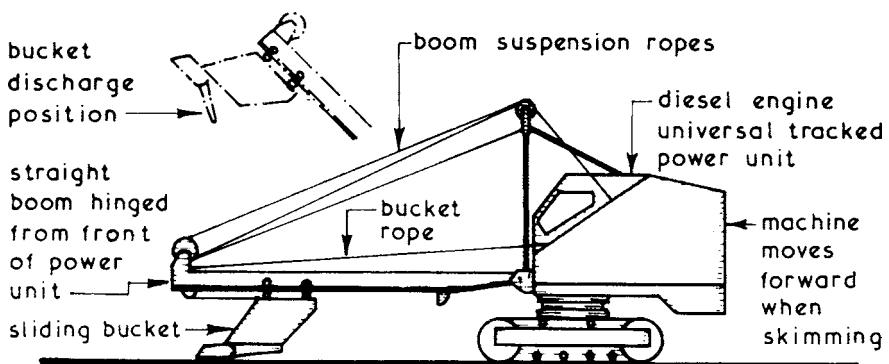

# Excavators

Face Shovels ~ the primary function of this piece of plant is to excavate above its own track or wheel level. They are available as a universal power unit-based machine or as a hydraulic purpose-designed unit. These machines can usually excavate any type of soil except rock which needs to be loosened, usually by blasting, prior to excavation. Face shovels generally require attendant haulage vehicles for the removal of spoil and a low-loader transport lorry for travel between sites. Most of these machines have a limited capacity of between 300 and 400 mm for excavation below their own track or wheel level.

Typical Face Shovel Details ~

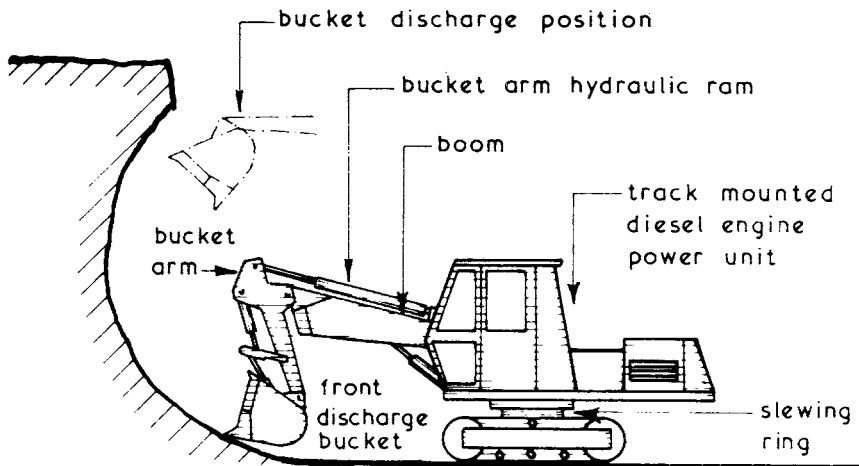
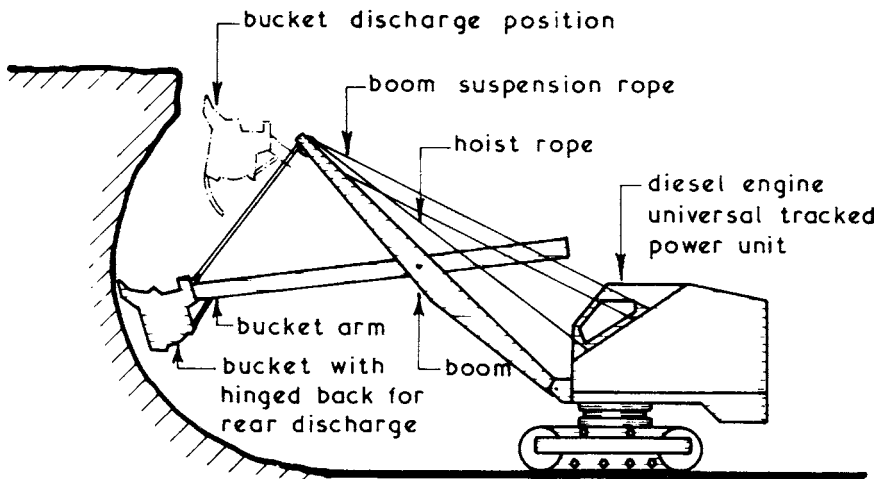

Backacters ~ these machines are suitable for trench, foundation and basement excavations and are available as a universal power unit-based machine or as a purpose-designed hydraulic unit. They can be used with or without attendant haulage vehicles since the spoil can be placed alongside the excavation for use in backfilling. These machines will require a low-loader transport vehicle for travel between sites. Backacters used in trenching operations with a bucket width equal to the trench width can be very accurate with a high output rating.

### Typical Backacter Details ~

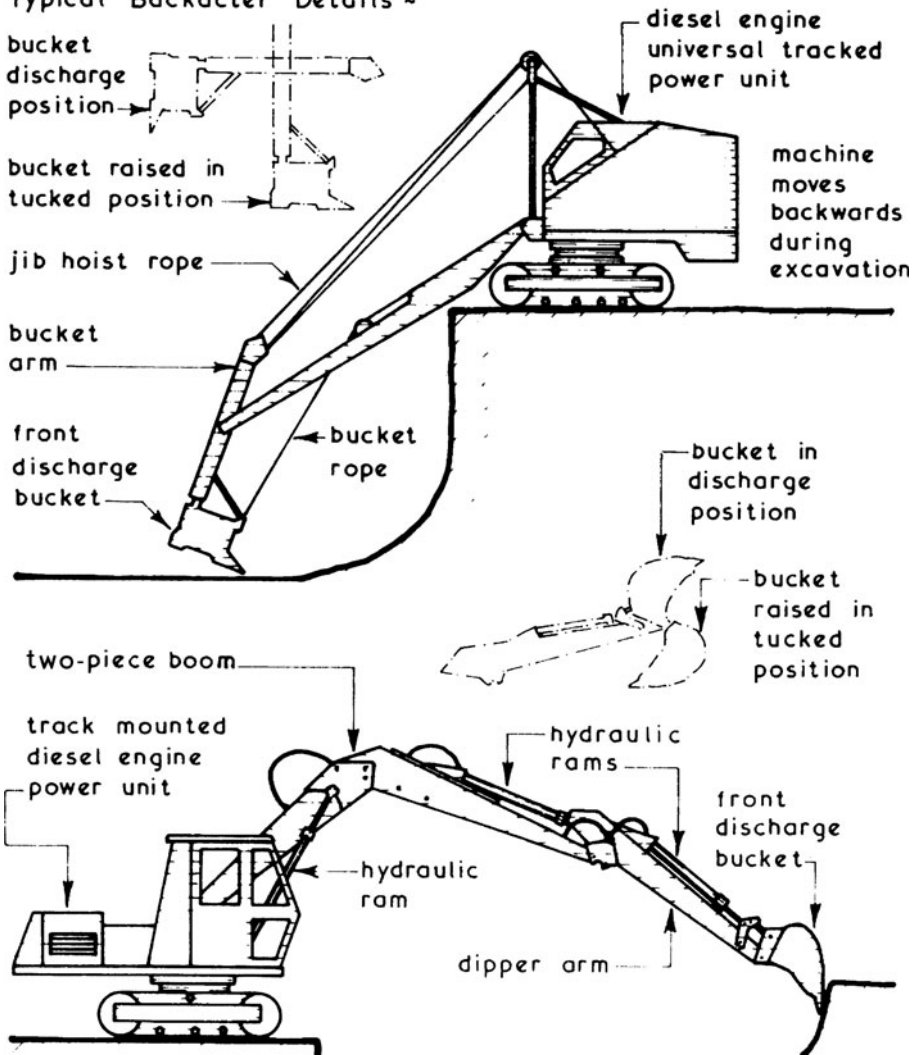



# Excavators

Draglines ~ these machines are based on the universal power unit with basic crane rigging to which is attached a drag bucket. The machine is primarily designed for bulk excavation in loose soils up to 3·000 below its own track level by swinging the bucket out to the excavation position and hauling or dragging it back towards the power unit. Dragline machines can also be fitted with a grab or clamshell bucket for excavating in very loose soils.

## Typical Dragline Details ~

bucket capacities up to 3·25 m<sup>3</sup> available

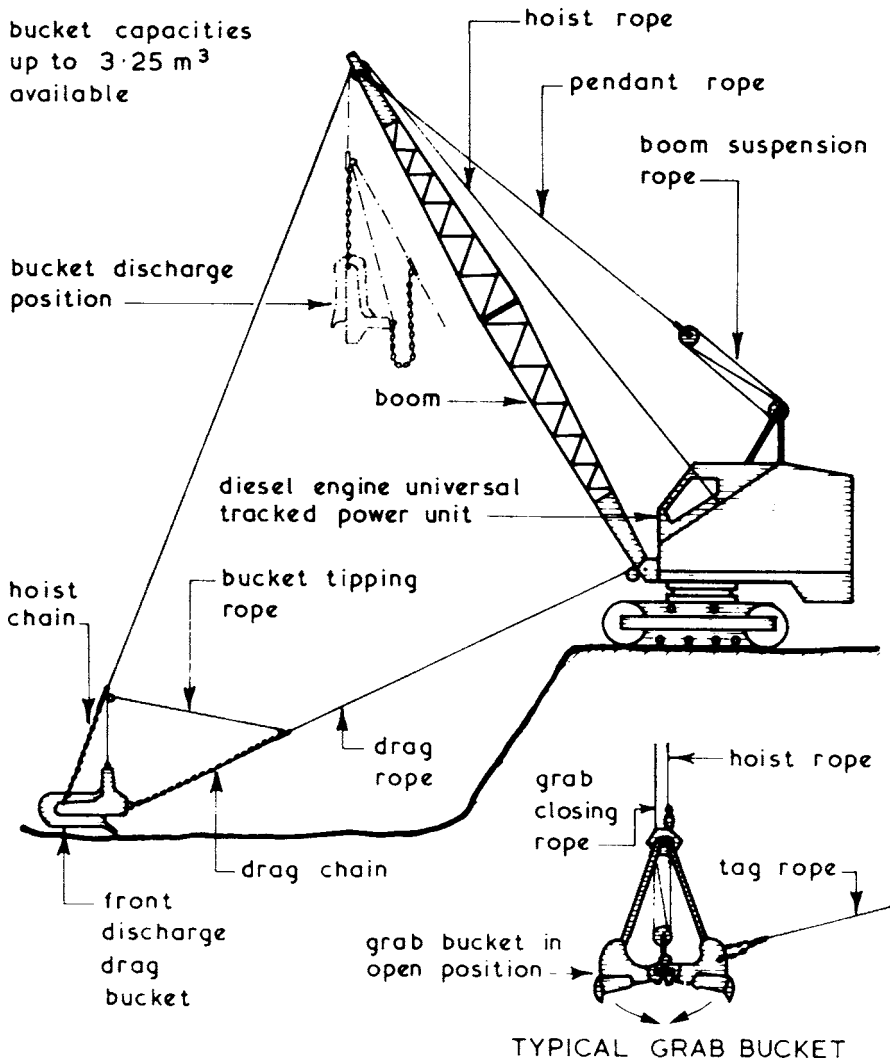

Multi-purpose Excavators ~ these machines are usually based on the agricultural tractor with two- or four-wheel drive and are intended mainly for use in conjunction with small excavation works such as those encountered by the small to medium sized building contractor. Most multi-purpose excavators are fitted with a loading/excavating front bucket and a rear backacter bucket both being hydraulically controlled. When in operation using the backacter bucket the machine is raised off its axles by rear-mounted hydraulic outriggers or jacks and in some models by placing the front bucket on the ground. Most machines can be fitted with a variety of bucket widths and various attachments such as bulldozer blades, scarifiers, grab buckets and post hole auger borers.

#### Typical Multi-purpose Excavator Details ~

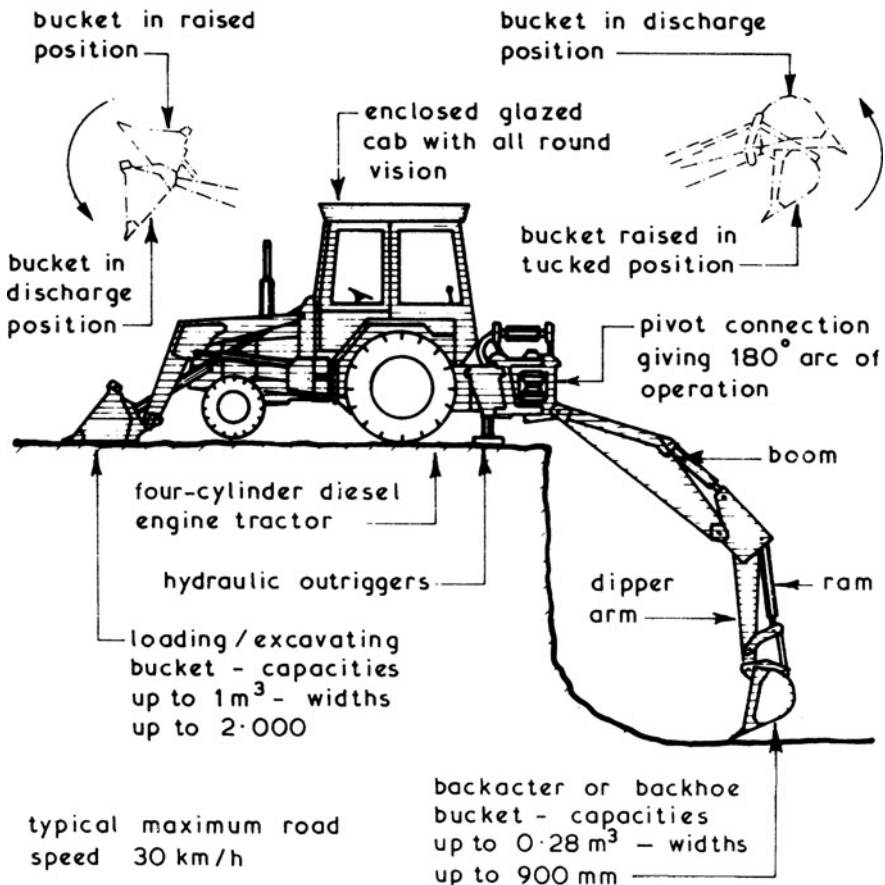

## Transport Vehicles

Transport Vehicles ~ these can be defined as vehicles whose primary function is to convey passengers and/or materials between and around building sites. The types available range from the conventional saloon car to the large low-loader lorries designed to transport other items of builders plant between construction sites and the plant yard or depot.

Vans - these transport vehicles range from the small two-person plus a limited amount of materials to the large vans with purpose-designed bodies such as those built to carry large sheets of glass. Most small vans are usually fitted with a petrol engine and are based on the manufacturer's standard car range whereas the larger vans are purpose designed with either petrol or diesel engines. These basic designs can usually be supplied with an uncovered tipping or non-tipping container mounted behind the passenger cab for use as a 'pick-up' truck.

Passenger Vehicles - these can range from a simple framed cabin which can be placed in the container of a small lorry or 'pick-up' truck to a conventional bus or coach. Vans can also be designed to carry a limited number of seated passengers by having fixed or removable seating together with windows fitted in the van sides, thus giving the vehicle a dual function. The number of passengers carried can be limited so that the driver does not have to hold a PSV (public service vehicle) licence.

Lorries - these are sometimes referred to as haul vehicles and are available as road- or site-only vehicles. Road haulage vehicles have to comply with all the requirements of the Road Traffic Acts which among other requirements limit size and axle loads. The off-highway or site-only lorries are not so restricted and can be designed to carry two to three times the axle load allowed on the public highway. Site-only lorries are usually specially designed to traverse and withstand the rough terrain encountered on many construction sites. Lorries are available as non-tipping, tipping and special-purpose carriers such as those with removable skips and those equipped with self-loading and unloading devices. Lorries specifically designed for the transportation of large items of plant are called low-loaders and are usually fitted with integral or removable ramps to facilitate loading and some have a winching system to haul the plant onto the carrier platform.

Dumpers ~ these are used for the horizontal transportation of materials on and off construction sites generally by means of an integral tipping skip. Highway dumpers are of a similar but larger design and can be used to carry materials such as excavated spoil along the roads. A wide range of dumpers are available of various carrying capacities and options for gravity or hydraulic discharge control with front tipping, side tipping or elevated tipping facilities. Special format dumpers fitted with flat platforms, rigs to carry materials skips and rigs for concrete skips for crane hoisting are also obtainable. These machines are designed to traverse rough terrain but they are not designed to carry passengers, and this misuse is the cause of many accidents involving dumpers.

Typical Dumper Details ~

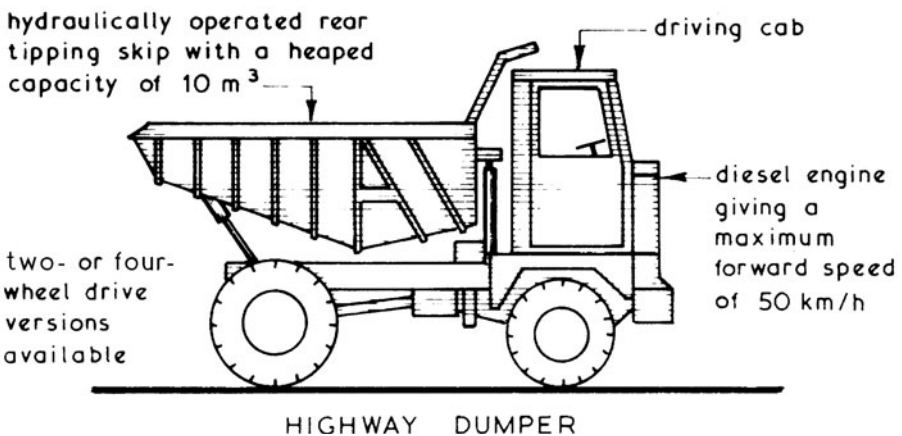
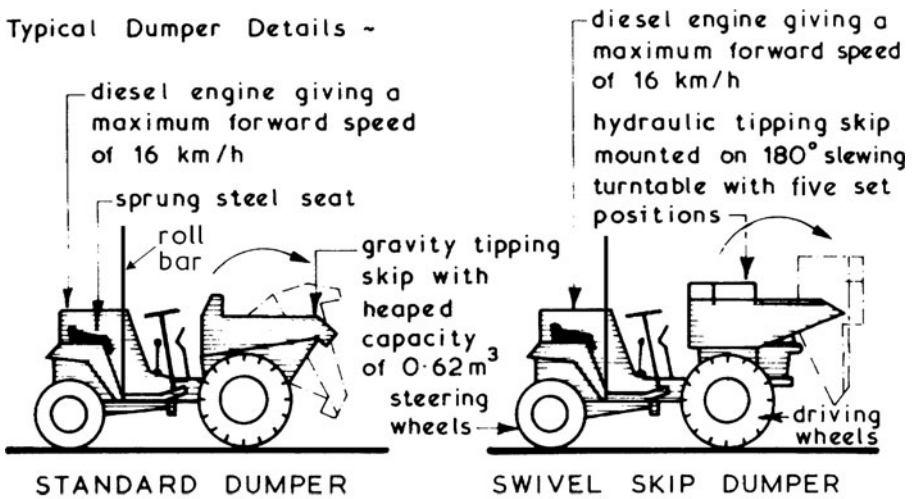

# Transport Vehicles

Fork Lift Trucks ~ these are used for the horizontal and limited vertical transportation of materials positioned on pallets or banded together such as brick packs. They are generally suitable for construction sites where the building height does not exceed three storeys. Although designed to negotiate rough terrain site fork lift trucks have a higher productivity on firm and level soils. Three basic fork lift truck formats are available, namely straight mast, overhead and telescopic boom with various height, reach and lifting capacities. Scaffolds onto which the load(s) are to be placed should be strengthened locally or a specially constructed loading tower could be built as an attachment to or as an integral part of the main scaffold.

## Typical Fork Lift Truck Details ~

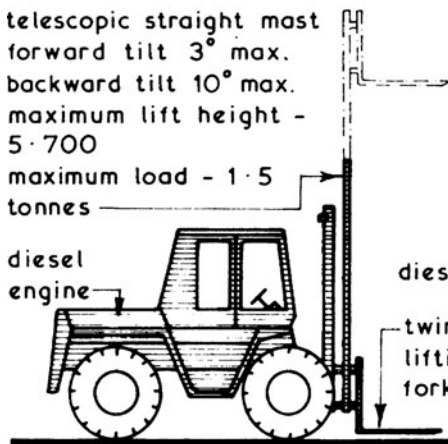

STRAIGHT MAST FORK LIFT

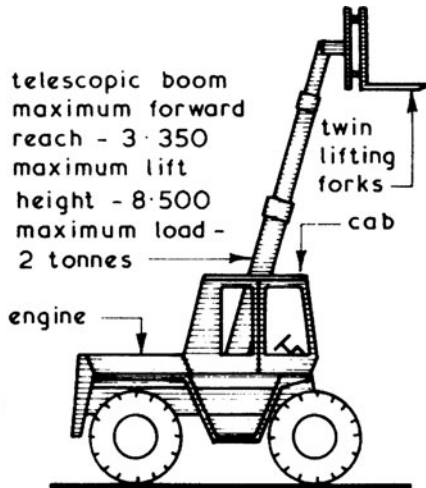

TELESCOPIC BOOM FORK LIFT

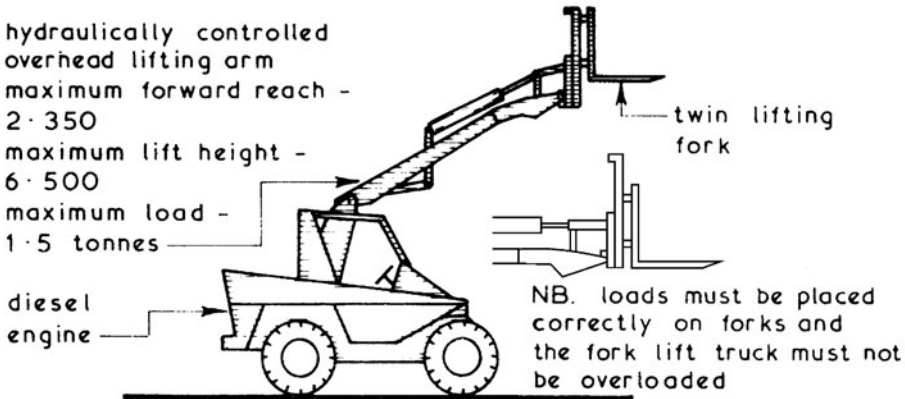

OVERHEAD FORK LIFT

Hoists ~ these are designed for the vertical transportation of materials, passengers, or materials and passengers (see page 218). Materials hoists are designed for one specific use (i.e. the vertical transportation of materials) and under no circumstances should they be used to transport passengers. Most material hoists are of a mobile format which can be dismantled, folded onto the chassis and moved to another position or site under their own power or towed by a haulage vehicle. When in use material hoists need to be stabilised and/or tied to the structure and enclosed with a protective screen.

#### Typical Materials Hoist Details ~

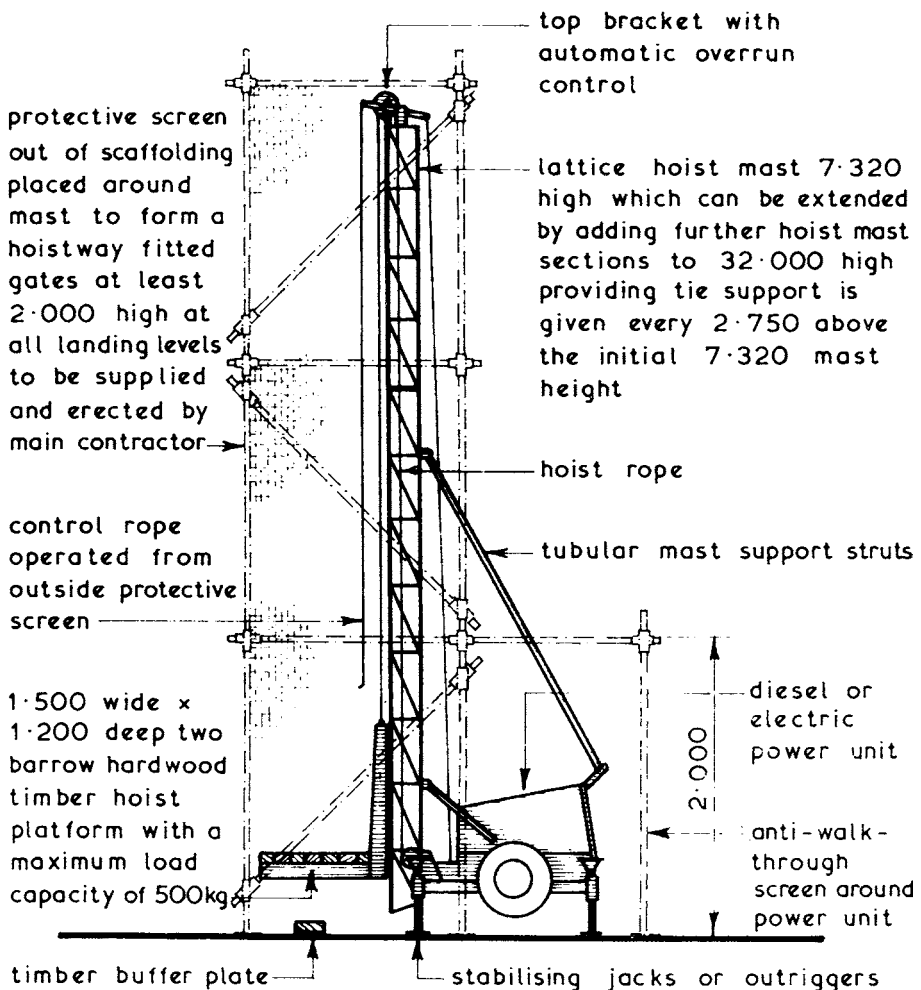

# Hoists

Passenger Hoists ~ these are designed to carry passengers, although most are capable of transporting a combined load of materials and passengers within the lifting capacity of the hoist. A wide selection of hoists are available ranging from a single cage with rope suspension to twin cages with rack and pinion operation mounted on two sides of a static tower.

## Typical Passenger Hoist Details ~

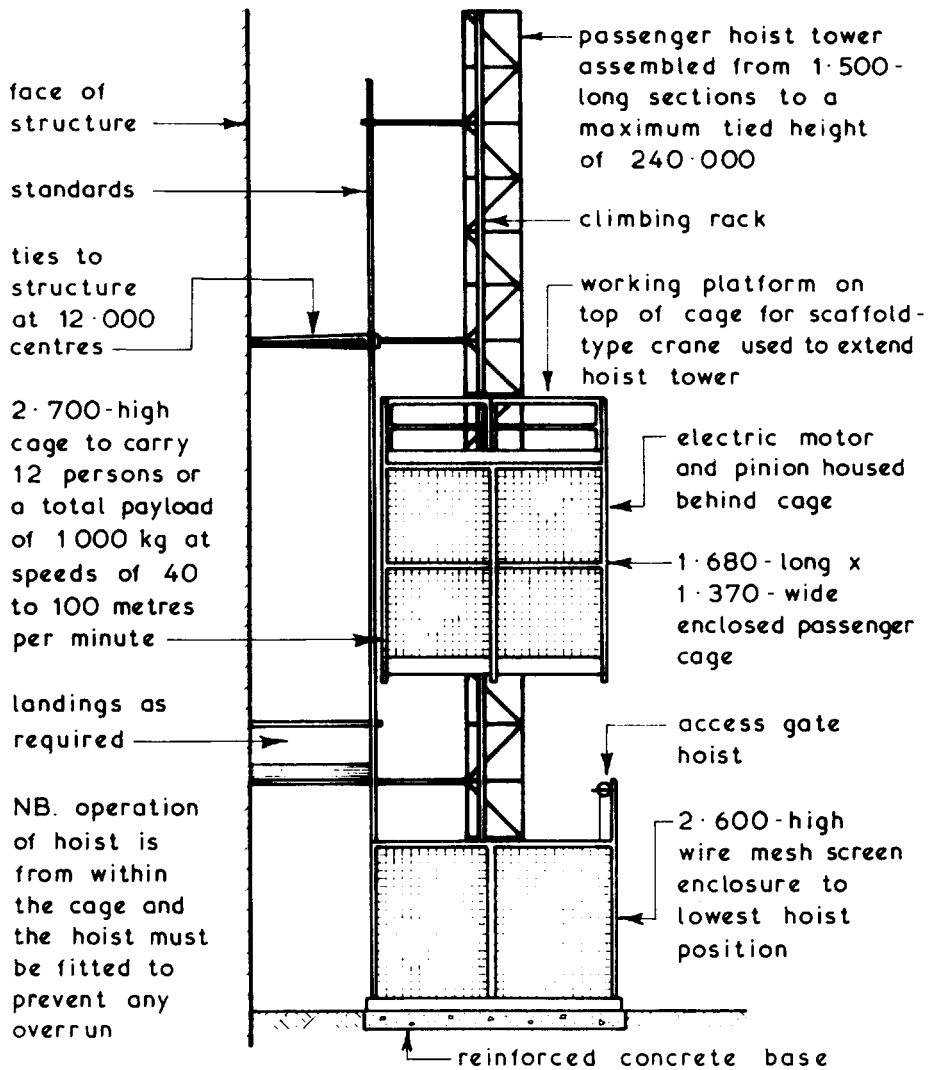

### Summary:

- Enclosures and gates at least two metres high to protect people at ground level from the moving platform and counterweight.
- Except when loading or unloading, access gates to be closed.
- Platform to have a fail-safe mechanism capable of supporting a full load in event of hoisting equipment failure.
- Automatic overrun prevention devices to be fitted at the top and bottom.
- Micro-switch feature on the gates to prevent platform being operated until the gates are properly closed and to prevent the gates being opened in between landings.
- Control from one point only if not controlled from within the cage.
- Operator to have an unobstructed view throughout the hoist's travel, or a banksman/signaller to be appointed to cover all landings.
- Additional safety features to include an automatic braking system, multiple roping and back-up cylinder for hydraulic hoists. Equipment specification to have a high factor of safety.
- Safe working load (SWL), otherwise expressed as *rated capacity* or *working load limit* for materials and passengers to be clearly displayed on the platform.
- Assembly and completion to be approved by an appropriately experienced and trained person. Pre-checks required at the start of each working day and after alterations and repairs. Periodic examinations to be undertaken as determined by use and exposure. All inspections to be documented, dated and filed.
- \* Passenger hoists to have the cage designed to retain occupants without becoming trapped or to be struck by debris falling down the hoist shaft.
- \* Material loads to be restrained or contained to prevent tipping or spillage.

Ref. The Lifting Operations and Lifting Equipment Regulations 1998 (known by the acronym LOLER).

NB. LOLER regulations are made under the Health and Safety at Work, etc. Act. They also apply to cranes, fork lift trucks and mobile elevating work platforms.



## Rubble Chutes and Skips

Rubble Chutes ~ these apply to contracts involving demolition, repair, maintenance and refurbishment. The simple concept of connecting several perforated dustbins is reputed to have been conceived by an ingenious site operative for the expedient and safe conveyance of materials.

In purpose-designed format, the tapered cylinders are produced from reinforced rubber with chain linkage for continuity. Overall unit lengths are generally 1100mm, providing an effective length of 1m. Hoppers and side entry units are made for special applications.

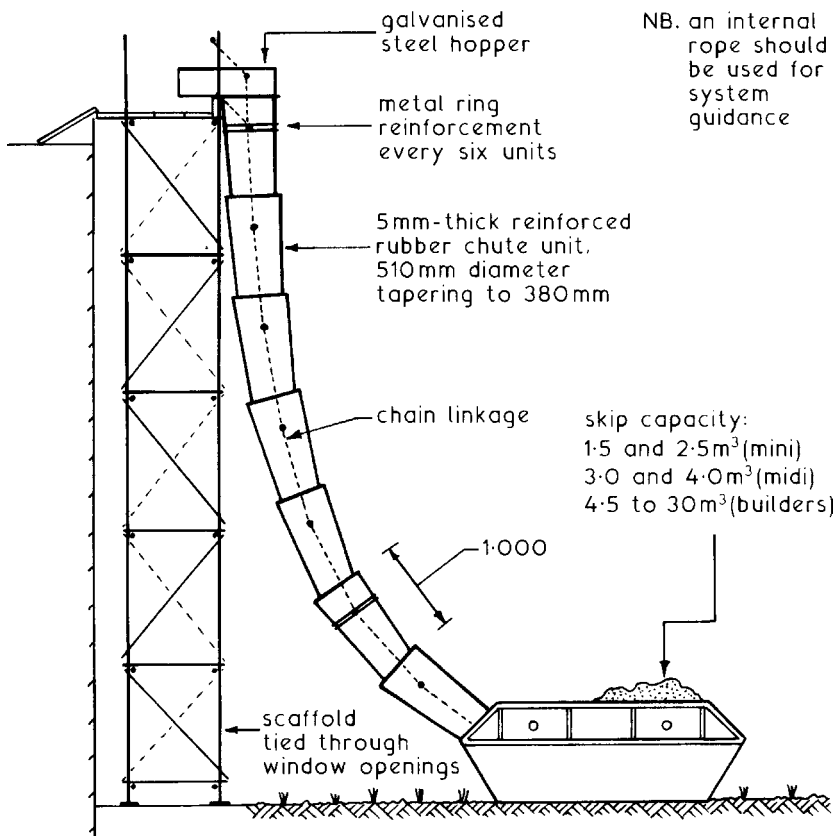

Ref. Highways Act - written permit (licence) must be obtained from the local authority highways department for use of a skip on a public thoroughfare. It will have to be illuminated at night and may require a temporary traffic light system to regulate vehicles.

Cranes ~ these are lifting devices designed to raise materials by means of rope operation and move the load horizontally within the limitations of any particular machine. The range of cranes available is very wide and therefore choice must be based on the loads to be lifted, height and horizontal distance to be covered, time period(s) of lifting operations, utilisation factors and degree of mobility required. Crane types can range from a simple rope and pulley or gin wheel to a complex tower crane but most can be placed within one of three groups, namely mobile, static and tower cranes.

Typical Crane Classifications ~

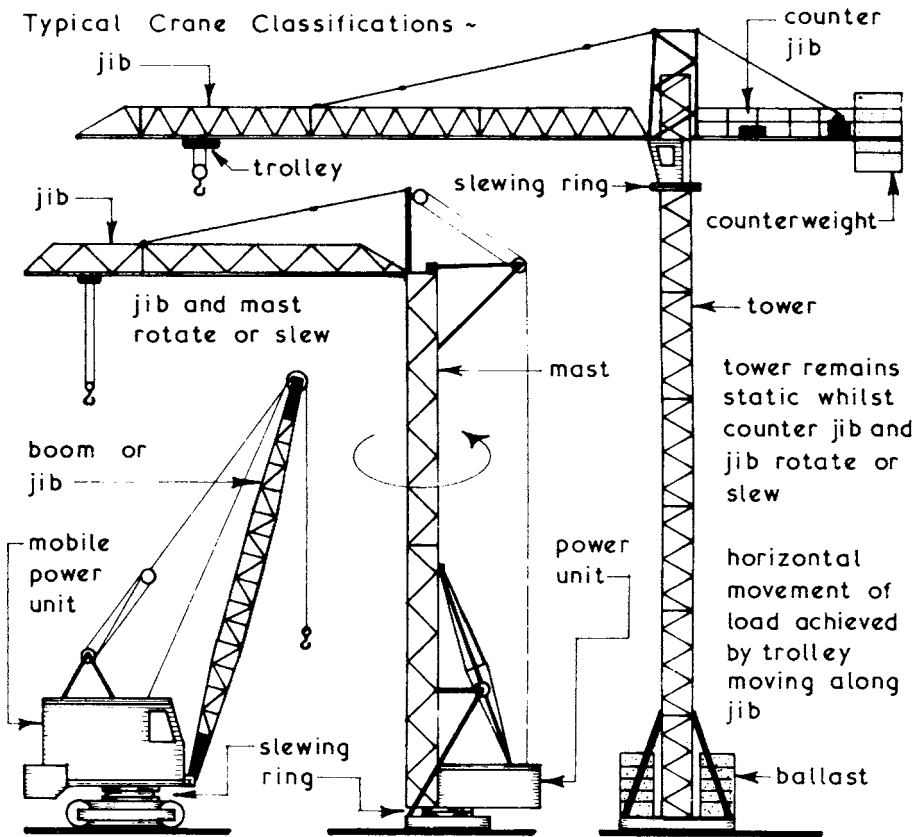

**MOBILE CRANE**

low pivot crane  
operating position  
can be changed by  
crane under its  
power

**STATIC CRANE**

low pivot crane  
operated from a  
fixed position

**TOWER CRANE**

high pivot crane  
can be operated from  
a fixed position or  
rail mounted and mobile

NB. static and tower cranes can be positioned  
closer to face of building than a low pivot mobile crane.

Self Propelled Cranes ~ these are mobile cranes mounted on a wheeled chassis and have only one operator position from which the crane is controlled and the vehicle driven. The road speed of this type of crane is generally low, usually not exceeding 30km p.h. A variety of self propelled crane formats are available ranging from short height lifting strut booms of fixed length to variable length lattice booms with a fly jib attachment.

Typical Self Propelled Crane Details ~

typical specification -

- main boom length 38·000 maximum
- lifting capacities for a 24·000 main boom length:
- stabilised on outriggers ~
- 31·4 tonnes at 4·000 radius
- 19·0 tonnes at 8·000 radius
- free on wheels ~
- 9·6 tonnes at 4·000 radius
- 4·9 tonnes at 8·000 radius

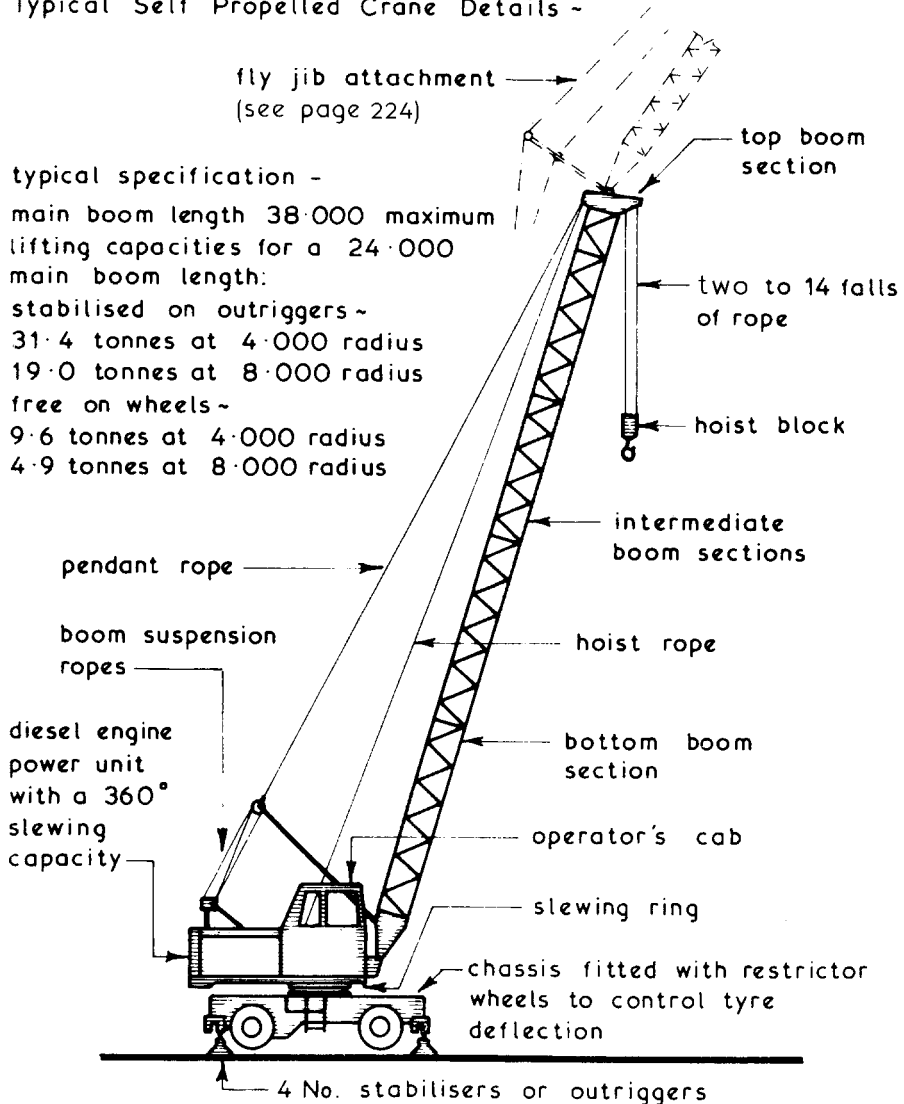

Lorry Mounted Cranes ~ these mobile cranes consist of a lattice or telescopic boom mounted on a specially adapted truck or lorry. They have two operating positions: the lorry being driven from a conventional front cab and the crane being controlled from a different location. The lifting capacity of these cranes can be increased by using outrigger stabilising jacks and the approach distance to the face of the building decreased by using a fly jib. Lorry mounted telescopic cranes require a firm surface from which to operate and because of their short site preparation time they are ideally suited for short hire periods.

#### Typical Lorry Mounted Telescopic Crane Details ~

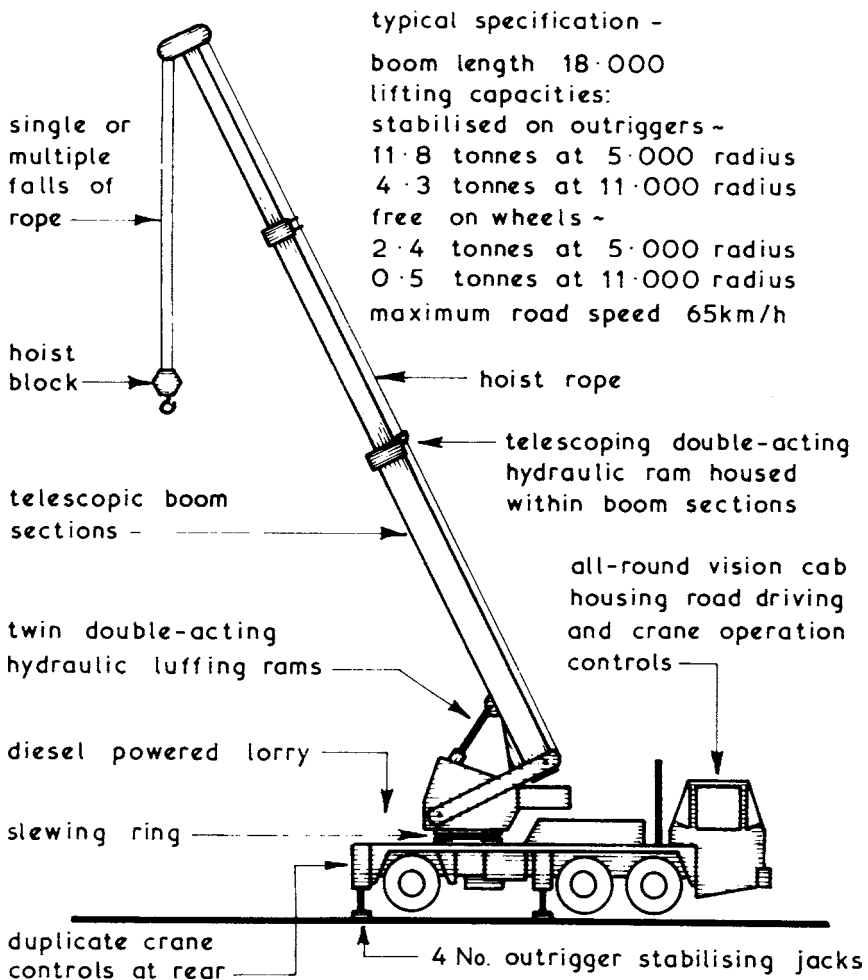

Lorry Mounted Lattice Jib Cranes ~ these cranes follow the same basic principles as the lorry mounted telescopic cranes but they have a lattice boom and are designed as heavy duty cranes with lifting capacities in excess of 100 tonnes. These cranes will require a firm, level surface from which to operate and can have a folding or sectional jib which will require the crane to be rigged on site before use.

Typical Lorry Mounted Lattice Jib Crane Details ~

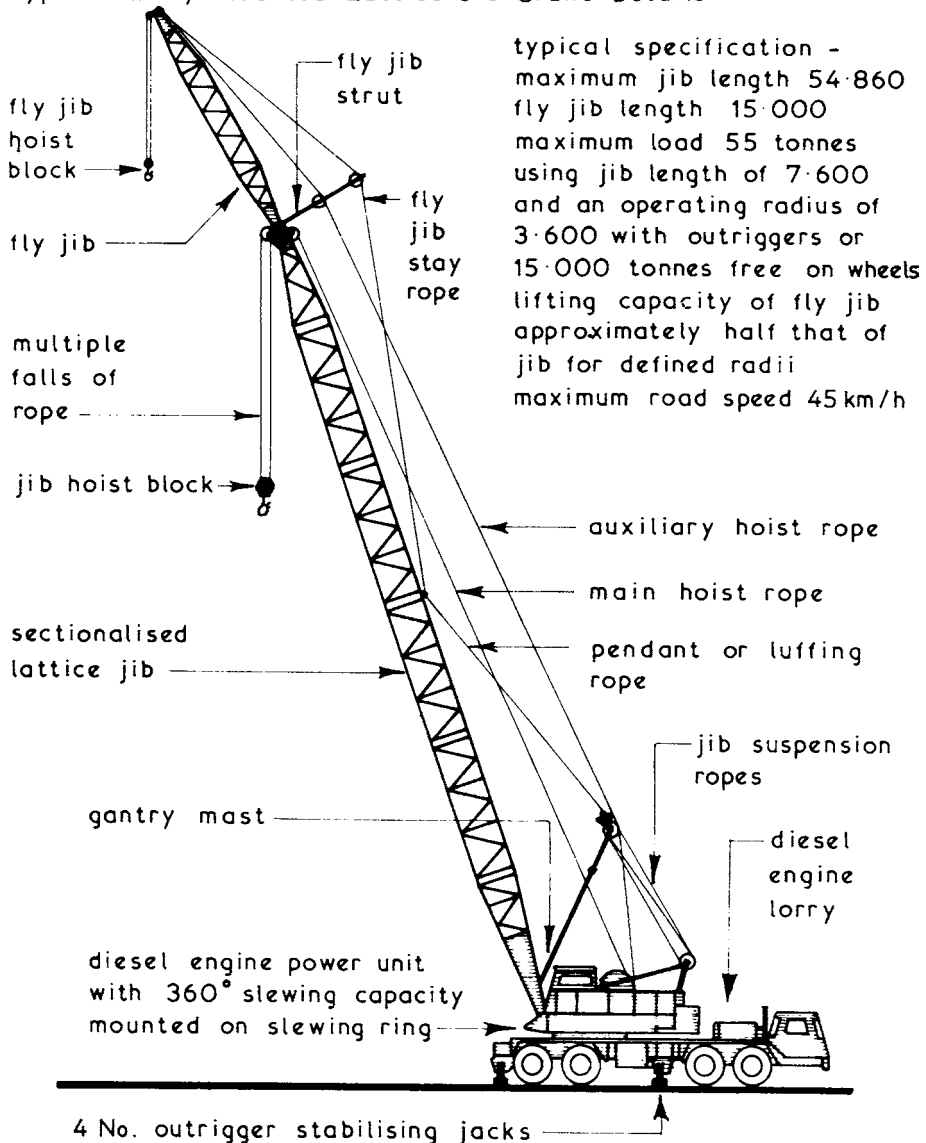

Track Mounted Cranes ~ these machines can be a universal power unit rigged as a crane (see page 210) or a purpose-designed track mounted crane with or without a fly jib attachment. The latter type are usually more powerful with lifting capacities of up to 45 tonnes. Track mounted cranes can travel and carry out lifting operations on most sites without the need for special road and hardstand provisions but they have to be rigged on arrival after being transported to site on a low-loader lorry.

#### Typical Track Mounted or Crawler Crane Details ~

maximum jib length 30·000 which can be extended by a fly jib attachment 9·000 or 12·000 long giving a load capacity of 5·5 tonnes at 7·000 radius or outreach for the combination

pendant or luffing rope

hoist rope

gantry mast

jib suspension ropes

sectionalised lattice jib

diesel powered crawler unit with 360° slewing capacity

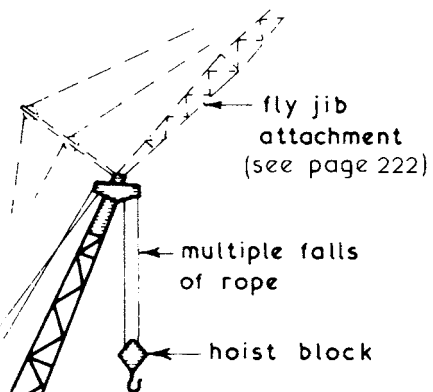

typical specification -  
 using a boom length of 30·000 maximum loads are:  
 15·8 tonnes at 4·000 radius  
 5·4 tonnes at 12·000 radius  
 2·2 tonnes at 24·000 radius  
 maximum travelling speed 1·6km/h

Gantry Cranes ~ these are sometimes called portal cranes and consist basically of two 'A' frames joined together with a cross-member on which transverse the lifting appliance. In small gantry cranes (up to 10 tonnes lifting capacity) the 'A' frames are usually wheel mounted and manually propelled whereas in the large gantry cranes (up to 100 tonnes lifting capacity) the 'A' frames are mounted on powered bogies running on rail tracks with the driving cab and lifting gear mounted on the cross-beam or gantry. Small gantry cranes are used primarily for loading and unloading activities in stock yards whereas the medium and large gantry cranes are used to straddle the work area such as in power station construction or in repetitive low- to medium-rise developments. All gantry cranes have the advantage of three-direction movement:

1. Transverse by moving along the cross-beam.
2. Vertical by raising and lowering the hoist block.
3. Horizontal by forward and reverse movements of the whole gantry crane.

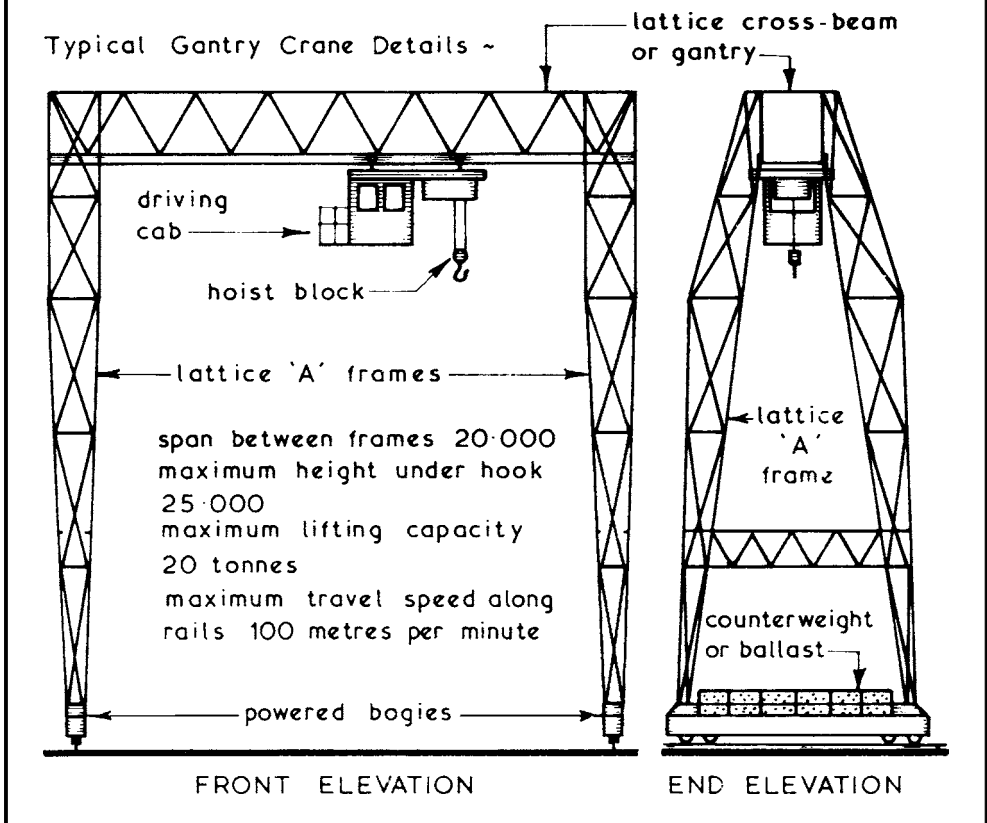

Mast Cranes ~ these are similar in appearance to the familiar tower cranes but they have one major difference in that the mast or tower is mounted on the slewing ring and thus rotates, whereas a tower crane has the slewing ring at the top of the tower and therefore only the jib portion rotates. Mast cranes are often mobile, self-erecting, of relatively low lifting capacity and are usually fitted with a luffing jib. A wide variety of models are available and have the advantage over most mobile low pivot cranes of a closer approach to the face of the building.

Typical Mast Crane Details ~

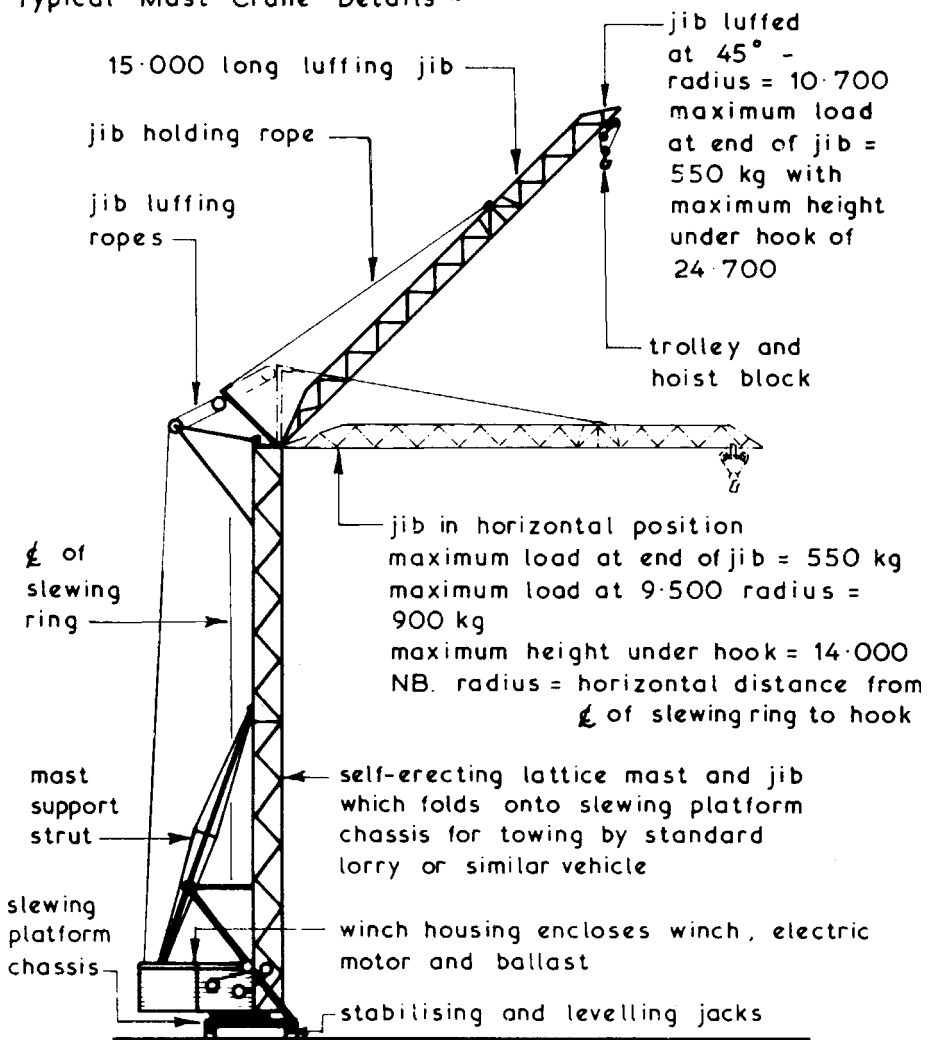



## Cranes

Tower Cranes ~ most tower cranes have to be assembled and erected on site prior to use and can be equipped with a horizontal or luffing jib. The wide range of models available often makes it difficult to choose a crane suitable for any particular site but most tower cranes can be classified into one of four basic groups thus:

1. Self-supporting Static Tower Cranes - high lifting capacity with the mast or tower fixed to a foundation base - they are suitable for confined and open sites (see page 229).
2. Supported Static Tower Cranes - similar in concept to self-supporting cranes and are used where high lifts are required, the mast or tower being tied at suitable intervals to the structure to give extra stability (see page 230).
3. Travelling Tower Cranes - these are tower cranes mounted on power bogies running on a wide gauge railway track to give greater site coverage - only slight gradients can be accommodated, therefore a reasonably level site or specially constructed railway support trestle is required (see page 231).
4. Climbing Cranes - these are used in conjunction with tall buildings and structures. The climbing mast or tower is housed within the structure and raised as the height of the structure is increased. Upon completion the crane is dismantled into small sections and lowered down the face of the building (see page 232).

All tower cranes should be left in an 'out of service' condition when unattended and in high wind conditions, the latter varying with different models but generally wind speeds in excess of 60 km p.h. would require the crane to be placed in an out of service condition thus:

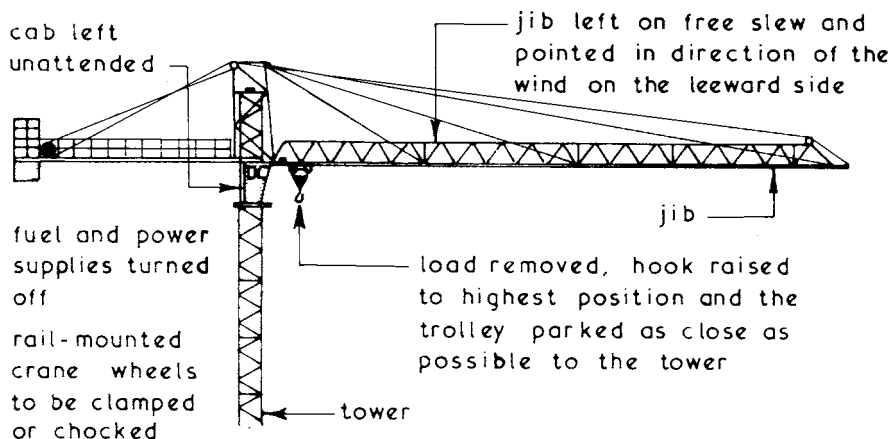

Typical Self-supporting Static Tower Crane Details ~

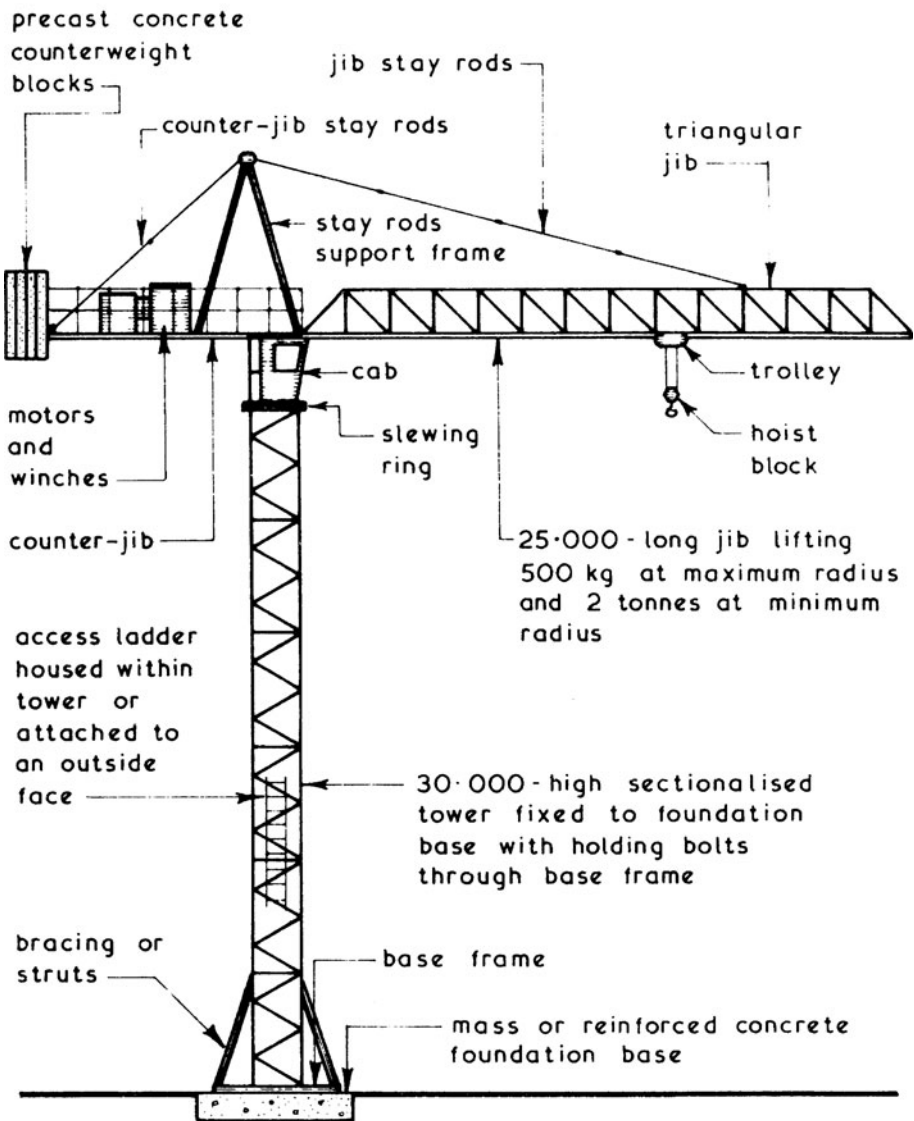

Tower Crane Operation ~ two methods are in general use:

1. Cab Control - the crane operator has a good view of most of the lifting operations from the cab mounted at the top of the tower but a second person or banksman is required to give clear signals to the crane operator and to load the crane.
2. Remote Control - the crane operator carries a control box linked by a wandering lead to the crane controls.

Typical Supported Static Tower Crane Details ~

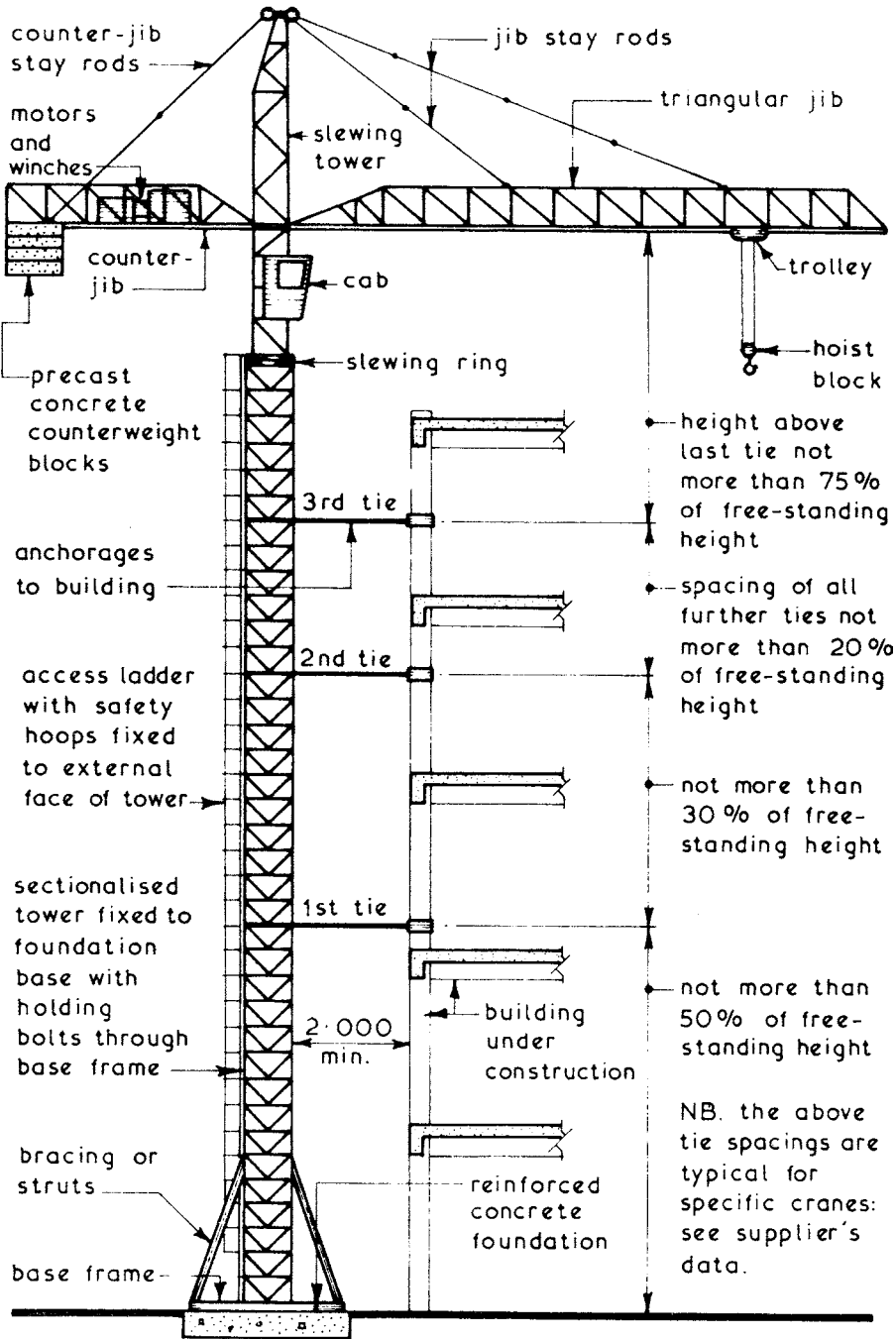

## Typical Travelling (Rail Mounted) Tower Crane Details ~

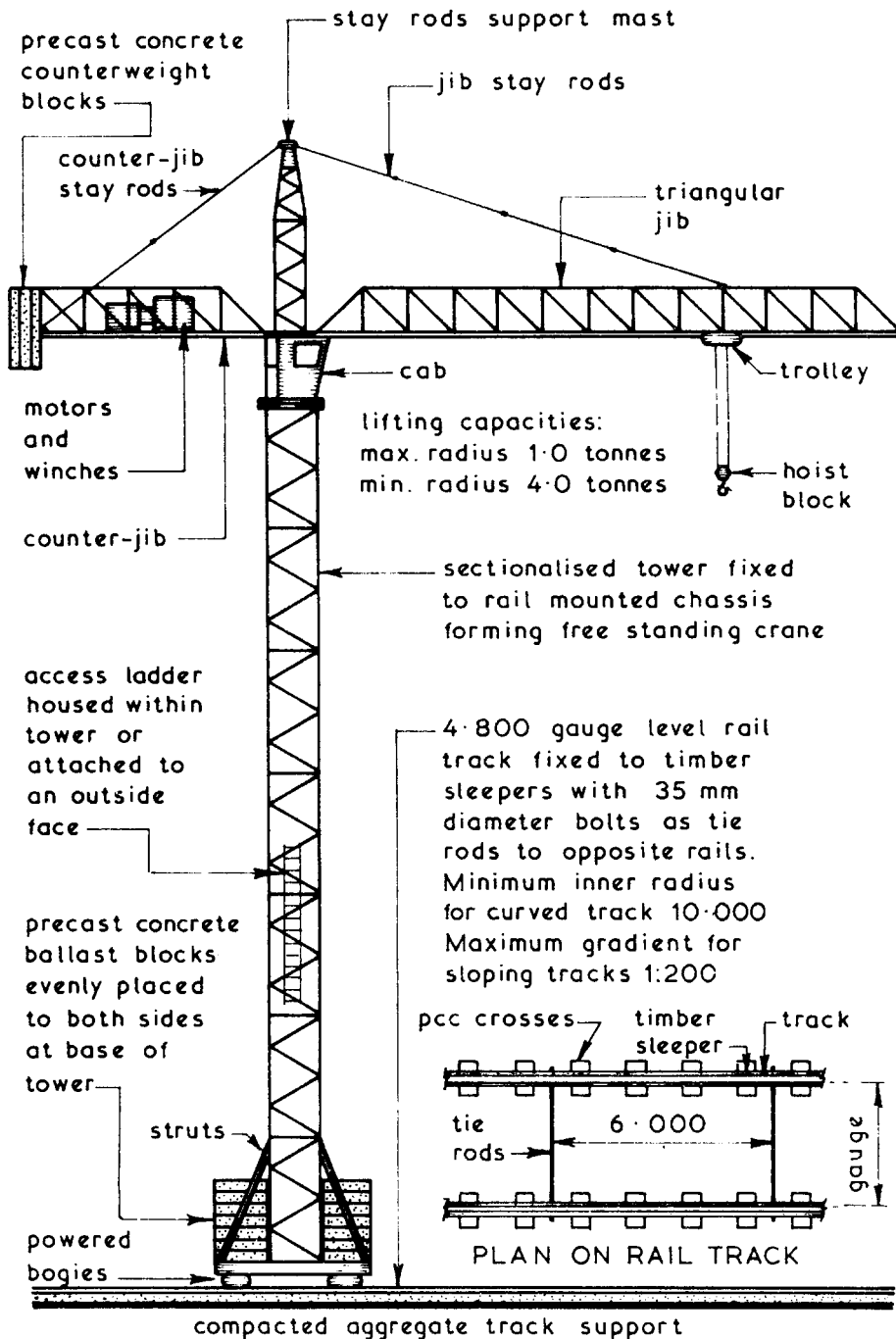

Typical Climbing Crane Details ~

crane raised one or two storeys at a time according to crane type and/or needs

crane raised to new working position after floor(s) have been cast and cured

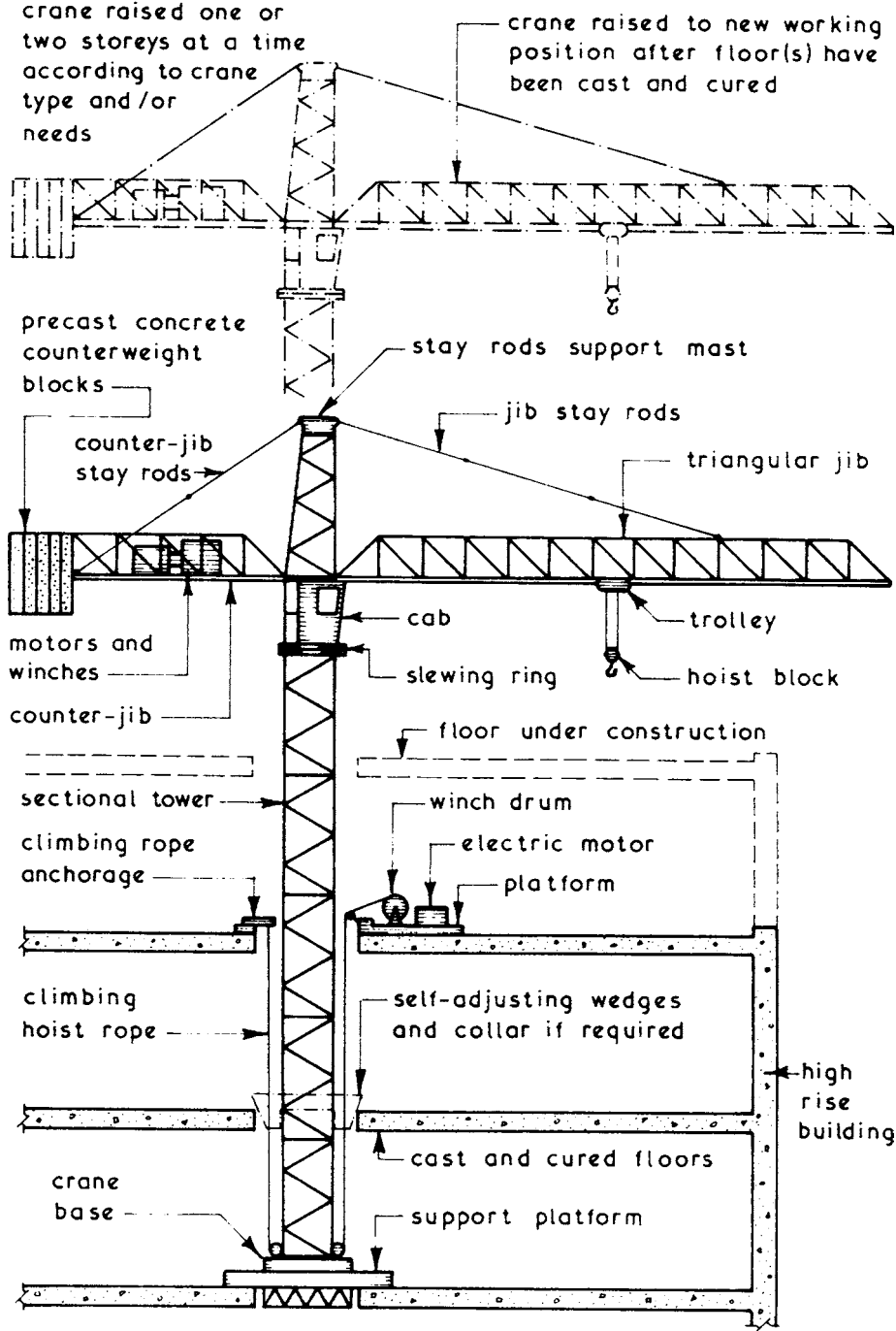

Concreting ~ this site activity consists of four basic procedures:

1. Material Supply and Storage - this is the receiving on site of the basic materials namely cement, fine aggregate and coarse aggregate and storing them under satisfactory conditions (see Concrete Production - Materials on pages 325 and 326).
2. Mixing - carried out in small batches this requires only simple handheld tools whereas when demand for increased output is required mixers or ready mixed supplies could be used (see Concrete Production on pages 327 to 332 and Concreting Plant on pages 234 to 239).
3. Transporting - this can range from a simple bucket to barrows and dumpers for small amounts. For larger loads, especially those required at high level, crane skips could be used:

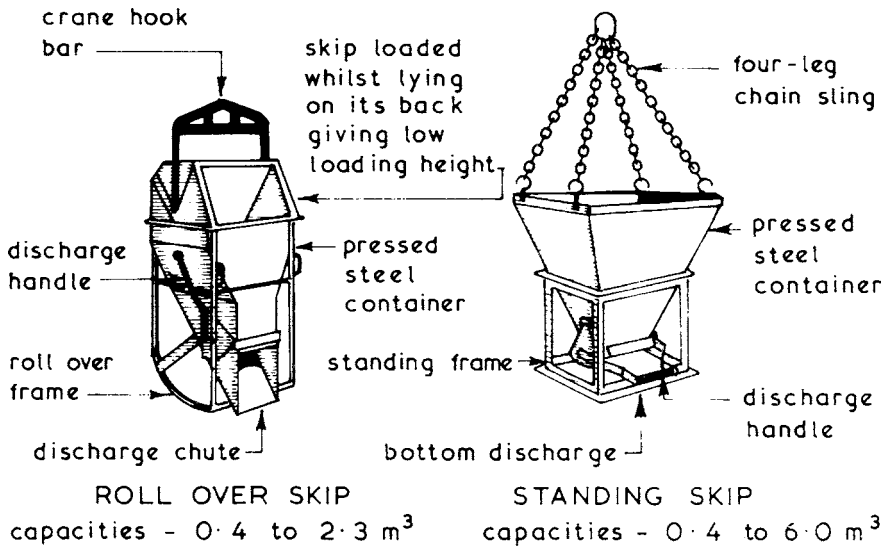

For the transportation of large volumes of concrete over a limited distance concrete pumps could be used (see page 237).

4. Placing Concrete - this activity involves placing the wet concrete in the excavation, formwork or mould; working the concrete between and around any reinforcement; vibrating and/or tamping and curing (see Concreting Plant on page 238 and Formwork on page 600).

Further refs. BS 8000-2.1 and 2.2: Workmanship on building sites. Codes of practice for concrete work. Also, BS EN 1992-1-1 and -2: Design of concrete structures.

## Concreting Plant

Concrete Mixers ~ apart from the very large output mixers most concrete mixers in general use have a rotating drum designed to produce a concrete without segregation of the mix.

Concreting Plant ~ the selection of concreting plant can be considered under three activity headings:

1. Mixing.
2. Transporting.
3. Placing.

Choice of Mixer ~ the factors to be taken into consideration when selecting the type of concrete mixer required are:

1. Maximum output required ( $\text{m}^3/\text{hour}$ ).
2. Total output required ( $\text{m}^3$ ).
3. Type or method of transporting the mixed concrete.
4. Discharge height of mixer (compatibility with transporting method).

Concrete mixer types are generally related to their designed output performance, therefore when the answer to the question 'How much concrete can be placed in a given time period?' or alternatively 'What mixing and placing methods are to be employed to mix and place a certain amount of concrete in a given time period?' has been found the actual mixer can be selected. Generally a batch mixing time of 5 minutes per cycle or 12 batches per hour can be assumed as a reasonable basis for assessing mixer output.

Small Batch Mixers ~ these mixers have outputs of up to 200 litres per batch with wheelbarrow transportation an hourly placing rate of 2 to 3  $\text{m}^3$  can be achieved. Most small batch mixers are of the tilting drum type. Generally these mixers are hand loaded which makes the quality control of successive mixes difficult to regulate.

Typical Example ~

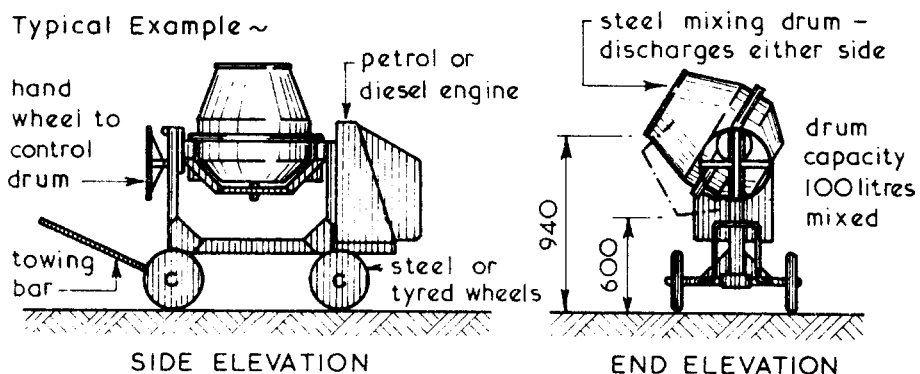

Medium Batch Mixers ~ outputs of these mixers range from 200 to 750 litres and can be obtained at the lower end of the range as a tilting drum mixer or over the complete range as a non-tilting drum mixer with either reversing drum or chute discharge. The latter usually has a lower discharge height. These mixers usually have integral weight batching loading hoppers, scraper shovels and water tanks, thus giving better quality control than the small batch mixers. Generally they are unsuitable for wheelbarrow transportation because of their high output.

Typical Examples ~

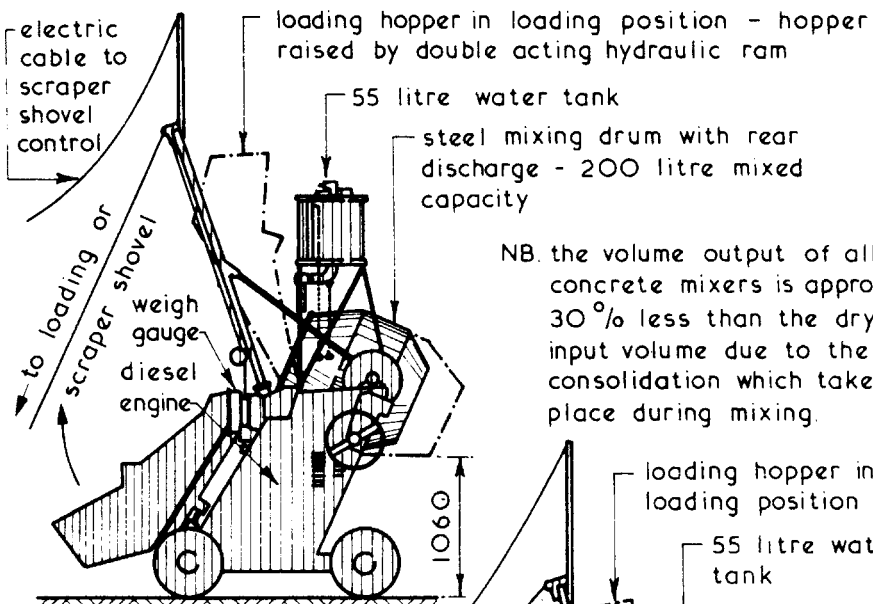

TILTING DRUM MIXER

NB. the volume output of all concrete mixers is approx. 30% less than the dry input volume due to the consolidation which takes place during mixing.

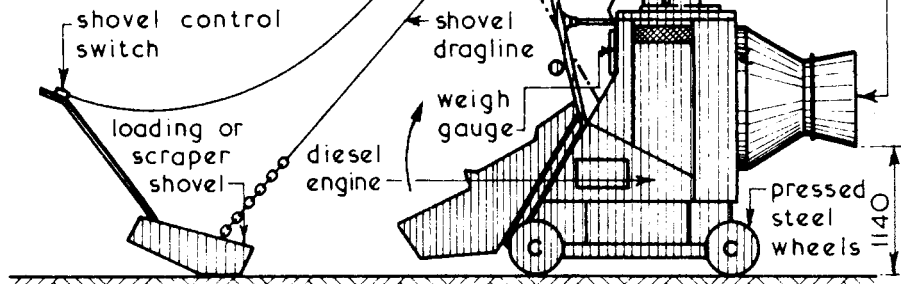

REVERSING DRUM MIXER



# Concreting Plant

Transporting Concrete ~ the usual means of transporting mixed concrete produced in a small capacity mixer is by wheelbarrow. The run between the mixing and placing positions should be kept to a minimum and as smooth as possible by using planks or similar materials to prevent segregation of the mix within the wheelbarrow.

Dumpers ~ these can be used for transporting mixed concrete from mixers up to 600 litre capacity when fitted with an integral skip and for lower capacities when designed to take a crane skip.

## Typical Examples ~

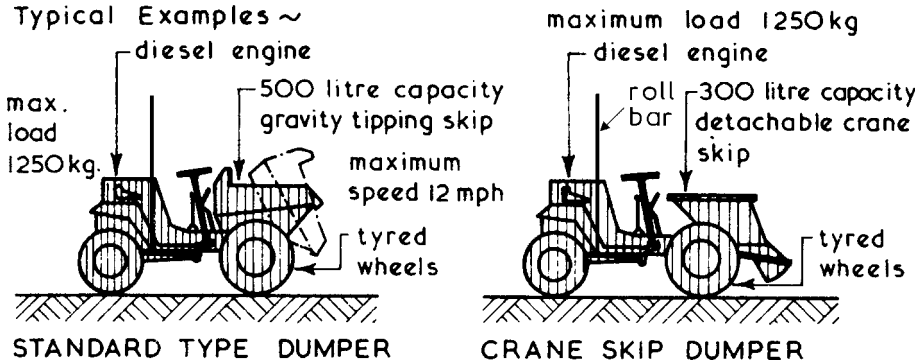

Ready Mixed Concrete Trucks ~ these are used to transport mixed concrete from a mixing plant or depot to the site. Usual capacity range of ready mixed concrete trucks is 4 to 6 m<sup>3</sup>. Discharge can be direct into placing position via a chute or into some form of site transport such as a dumper, crane skip or concrete pump.

## Typical Details ~

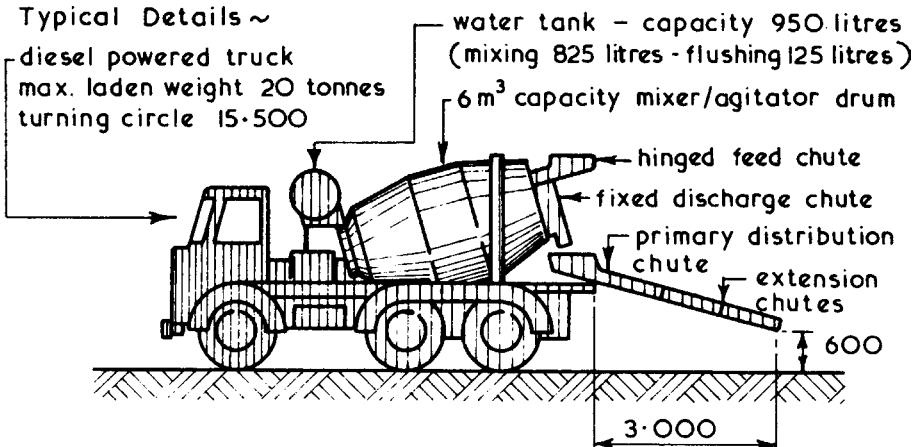

Concrete Pumps ~ these are used to transport large volumes of concrete in a short time period (up to 100 m<sup>3</sup> per hour) in both the vertical and horizontal directions from the pump position to the point of placing. Concrete pumps can be trailer or lorry mounted and are usually of a twin cylinder hydraulically driven format with a small bore pipeline (100 mm diameter) with pumping ranges of up to 85-000 vertically and 200-000 horizontally depending on the pump model and the combination of vertical and horizontal distances. It generally requires about 45 minutes to set up a concrete pump on site including coating the bore of the pipeline with a cement grout prior to pumping the special concrete mix. The pump is supplied with pumpable concrete by means of a constant flow of ready mixed concrete lorries throughout the pumping period after which the pipeline is cleared and cleaned. Usually a concrete pump and its operator(s) are hired for the period required.

Typical Concrete Pump Details ~

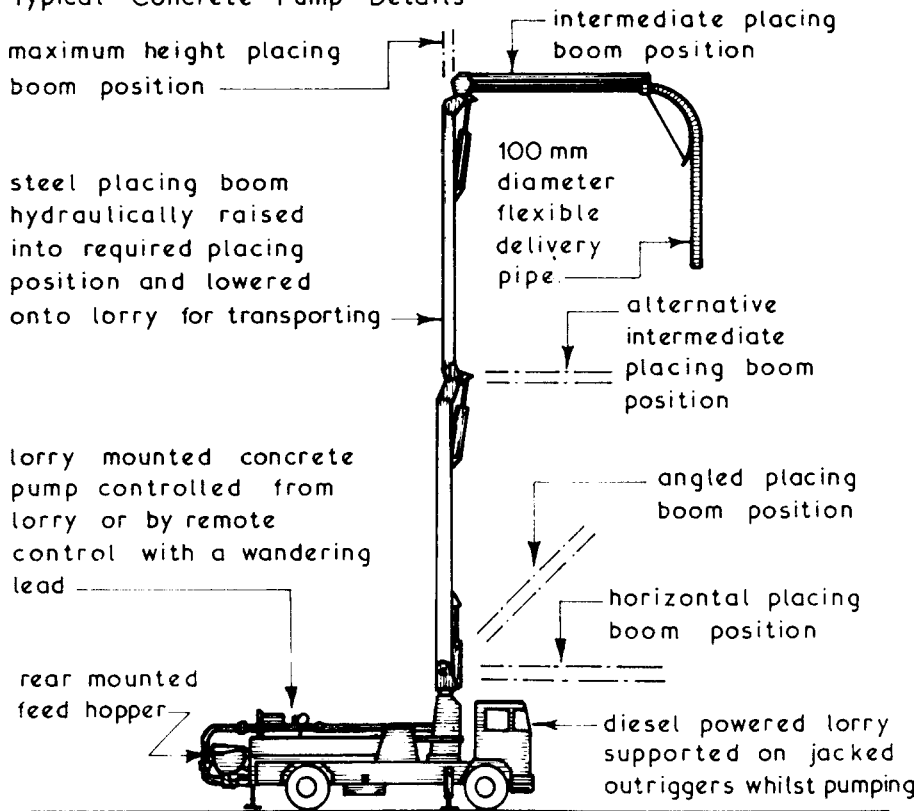

# Concreting Plant

Placing Concrete ~ this activity is usually carried out by hand with the objectives of filling the mould, formwork or excavated area to the correct depth, working the concrete around any inserts or reinforcement and finally compacting the concrete to the required consolidation. The compaction of concrete can be carried out using simple tamping rods or boards, or alternatively it can be carried out with the aid of plant such as vibrators.

Poker Vibrators ~ these consist of a hollow steel tube casing containing a rotating impeller which generates vibrations as its head comes into contact with the casing -

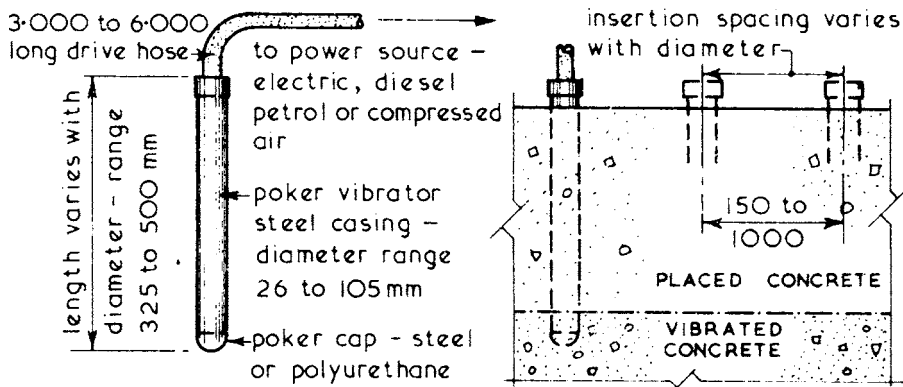

Poker vibrators should be inserted vertically and allowed to penetrate 75mm into any previously vibrated concrete.

Clamp or Tamping Board Vibrators ~ clamp vibrators are powered either by compressed air or electricity whereas tamping board vibrators are usually petrol driven -

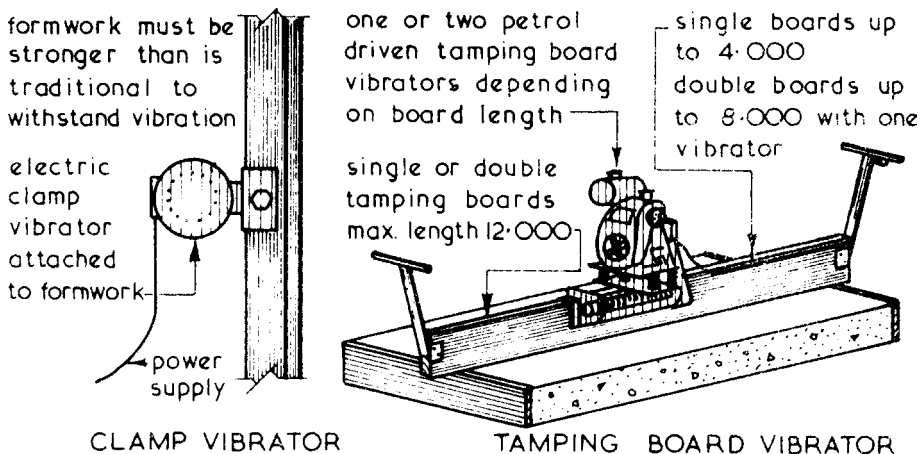

Power Float - a hand-operated electric motor or petrol engine, surmounted over a mechanical surface skimmer. Machines are provided with an interchangeable revolving disc and a set of blades. These are used in combination to produce a smooth, dense and level surface finish to in-situ concrete beds.

The advantages offset against the cost of plant hire are:

- \* Eliminates the time and materials needed to apply a finishing screed.
- \* A quicker process and less labour-intensive than hand trowelling.

Application - after transverse tamping, the concrete is left to partially set for a few hours. Amount of setting time will depend on a number of variables, including air temperature and humidity, mix specification and machine weight. As a rough guide, walking on the concrete will leave indentations of about 3-4 mm. A surfacing disc is used initially to remove high tamping lines, before two passes with blades to finish and polish the surface.

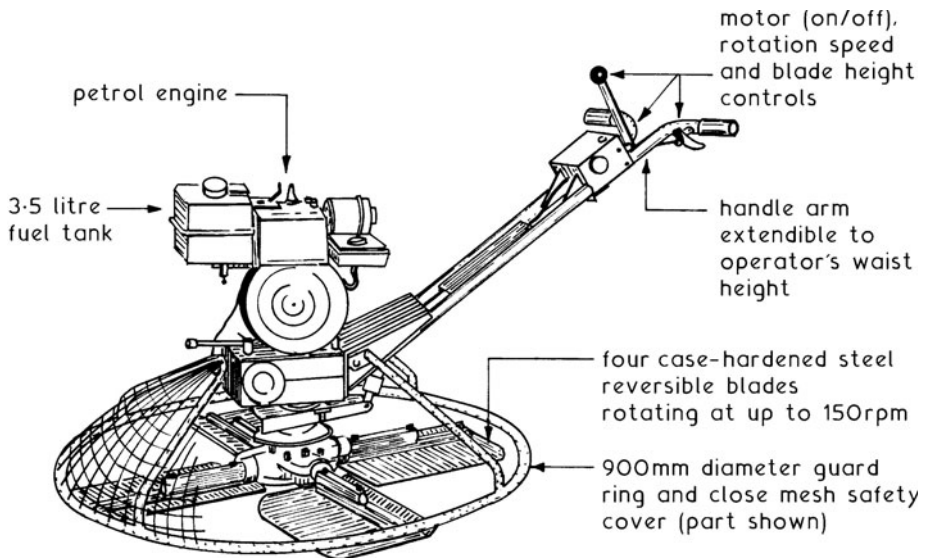

Power or mechanical float

## Concrete – Curing (1)

**Definition** ~ curing of concrete can be explained as a series of chemical reactions that occur between cement in a concrete mix and the water, a process known as hydration. For concrete to achieve its correct design strength, hydration must be carefully controlled. In effect, it is the process of initial setting of concrete into a solid mass and subsequent hardening.

**Adhesion** ~ cement combining with water forms an adhesive paste. It sets slowly, gaining strength and hardening over time. In a thoroughly mixed batch of concrete the paste functions as a glue, adhering to the aggregates and binding them into a solid mass. Hydration continues indefinitely as the concrete gets harder. The critical period is within the first few hours as the concrete changes state from a liquid to a solid. Under controlled curing conditions concrete attains design strength after about 28 days.

**Temperature** ~ the hydration of cement generates a rise in temperature, possibly up to 20° C, therefore it is very important to regulate the cement content (see w/c ratio on page 329). Too much cement will cause excessive thermal expansion followed by contraction on cooling and setting, introducing potential for thermal stress cracking. The ideal ambient temperature during concreting is between 10° C and 24° C. This should be maintained throughout curing.

**Water Retention** ~ initial setting time is the most crucial for concrete to gain its design strength, therefore water must be retained and prevented from evaporating. Conversely, the addition of water from exposure to rain during the initial setting must also be prevented. Once set (24 hours after pouring) surface water can be a useful means of hydration control. Ideally, fresh concrete should be kept moist for at least 7 days when using OPC, otherwise shrinkage will induce tensile stresses manifesting in surface cracks. With other cements such as the rapid setting and hardening types, the manufacturer should be consulted to establish optimum curing time.

**Curing Methods** ~ the longer the time during which fresh concrete is kept moist, the more efficient will be the hardening process. Concrete should be protected from exposure to sunshine and high air temperatures in summer, drying winds, potentially freezing low air temperatures in winter and low relative humidity.

Setting ~ concrete will normally set within the working day. This can vary somewhat with air temperatures as indicated below.

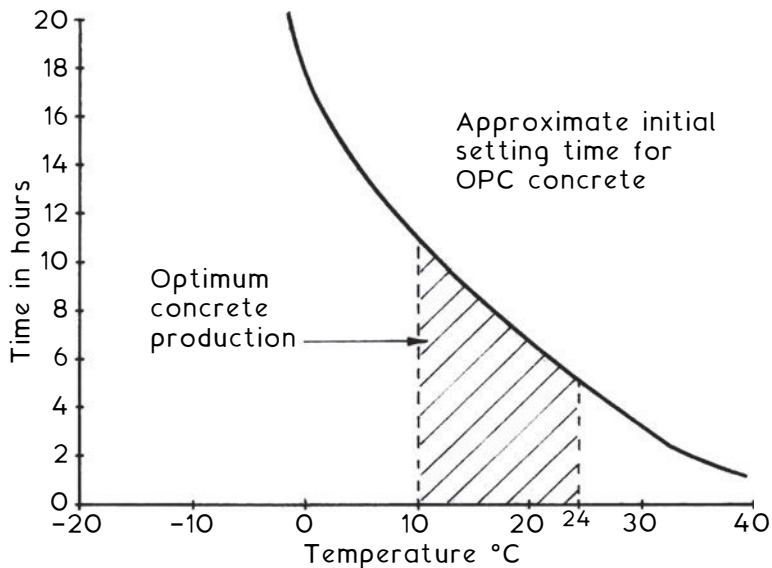

Methods for Retaining Water Content in Set Concrete ~

- Sealing by leaving the formwork/shuttering in place.
- Covering with an impervious membrane, e.g. plastic sheeting.
- Spraying with water.
- Spraying with a purpose made curing agent. A solvent based acrylic resin will also function as a surface sealant (polyurethane acrylic).
- Ponding by covering the concrete with a layer of water creating a temporary reservoir.
- For winter use, an insulating cover or blanket possibly with an electric element to prevent water content freezing.
- Steaming - appropriate in factory controlled situations. A sealed compartment contains circulation of a vapour of warm moist air.

Note: Period of curing should be as long as is practicable, maintained above 5°C for a minimum of 7 days. Demand for progress may limit these ideal measures hence the availability of mix additives and special cements with rapid setting and hardening properties. These should only be used with strict application of the manufacturer's instructions and/or to the structural engineer's specification.

*This page intentionally left blank*

## 4 SUBSTRUCTURE

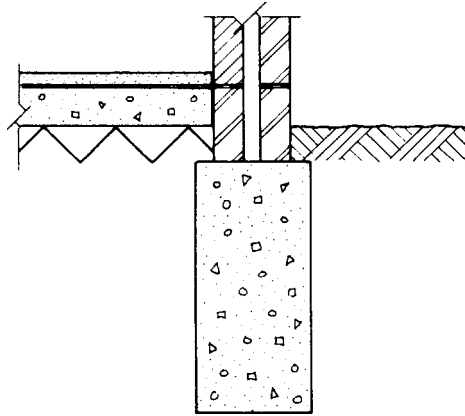

FOUNDATIONS – FUNCTION, MATERIALS AND SIZING

FOUNDATION BEDS

SHORT BORED PILE FOUNDATIONS

FOUNDATION TYPES AND SELECTION

PILED FOUNDATIONS

RETAINING WALLS

GABIONS AND MATTRESSES

BASEMENT CONSTRUCTION

WATERPROOFING BASEMENTS

EXCAVATIONS

CONCRETE PRODUCTION

COFFERDAMS

STEEL SHEET PILING

CAISSONS

UNDERPINNING

GROUND WATER CONTROL

SOIL STABILISATION AND IMPROVEMENT

RECLAMATION OF WASTE LAND

TREATMENT OF CONTAMINATED SUBSOIL



## Foundations – Functions

Foundations ~ the function of any foundation is to safely sustain and transmit to the ground on which it rests the combined dead, imposed and wind loads in such a manner as not to cause any settlement or other movement which would impair the stability or cause damage to any part of the building.

Example ~

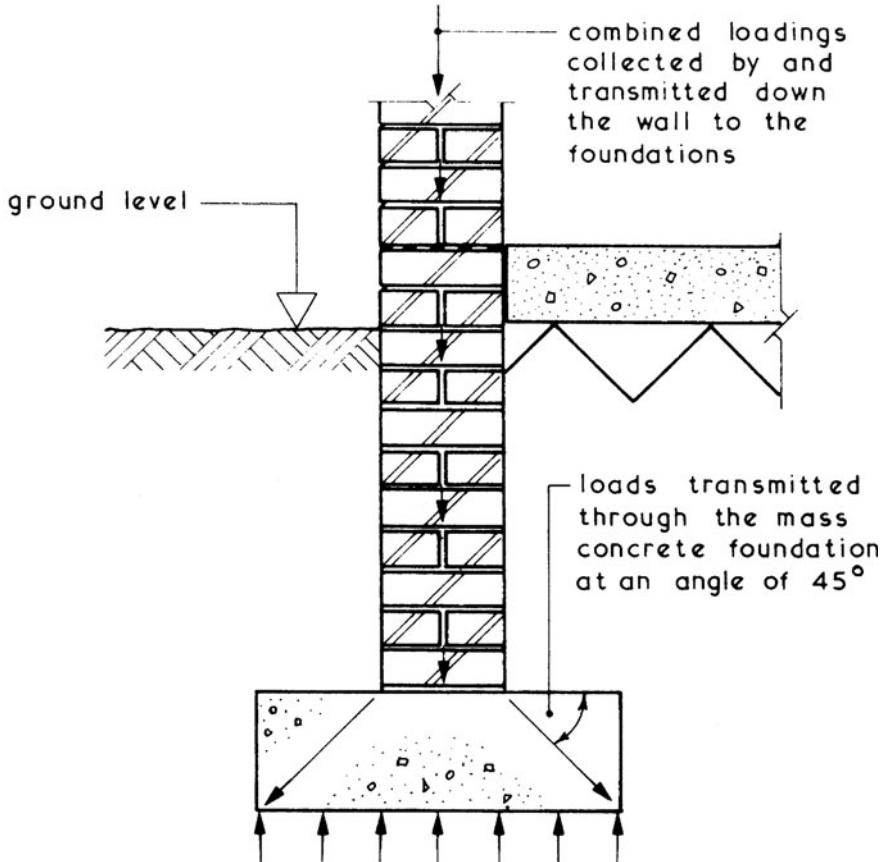

Subsoil beneath foundation is compressed and reacts by exerting an upward pressure to resist foundation loading. If foundation load exceeds maximum passive pressure of ground (i.e. bearing capacity) a downward movement of the foundation could occur. Remedy is to increase plan size of foundation to reduce the load per unit area or alternatively reduce the loadings being carried by the foundations.

Subsoil Movements ~ these are due primarily to changes in volume when the subsoil becomes wet or dry and occurs near the upper surface of the soil. Compact granular soils such as gravel suffer very little movement whereas cohesive soils such as clay do suffer volume changes near the upper surface. Similar volume changes can occur due to water held in the subsoil freezing and expanding – this is called Frost Heave.

Typical Examples ~

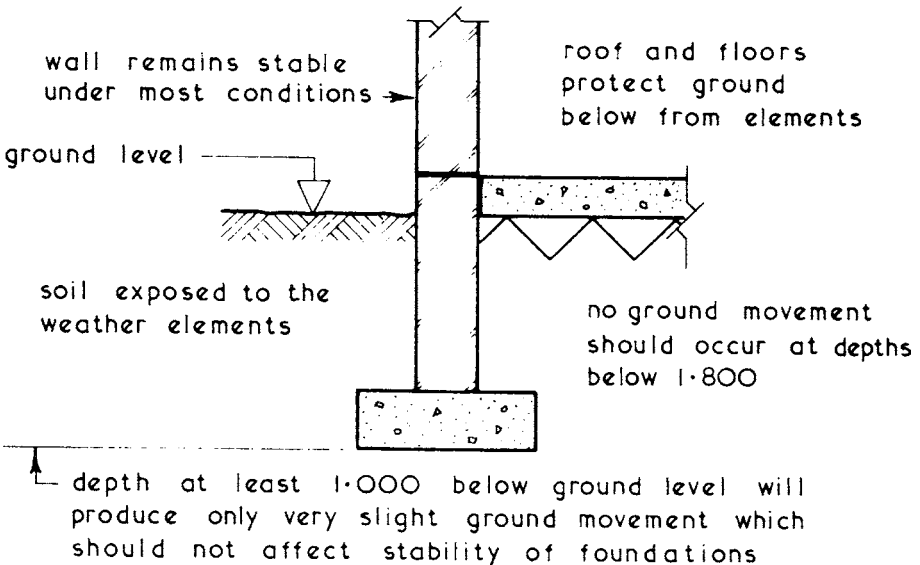
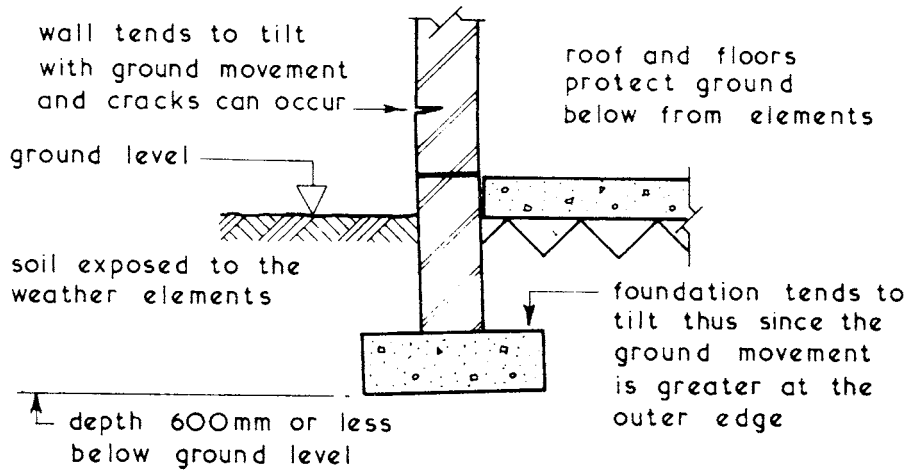

## Foundations – Subsoil Movements

Trees ~ damage to foundations. Substructural damage to buildings can occur with direct physical contact by tree roots. More common is the indirect effect of moisture shrinkage or heave, particularly apparent in clay subsoils.

Shrinkage is most evident in long periods of dry weather, compounded by moisture abstraction from vegetation. Notably broad-leaved trees such as oak, elm and poplar in addition to the thirsty willow species. Heave is the opposite. It occurs during wet weather and is compounded by previous removal of moisture-dependent trees that would otherwise effect some drainage and balance to subsoil conditions.

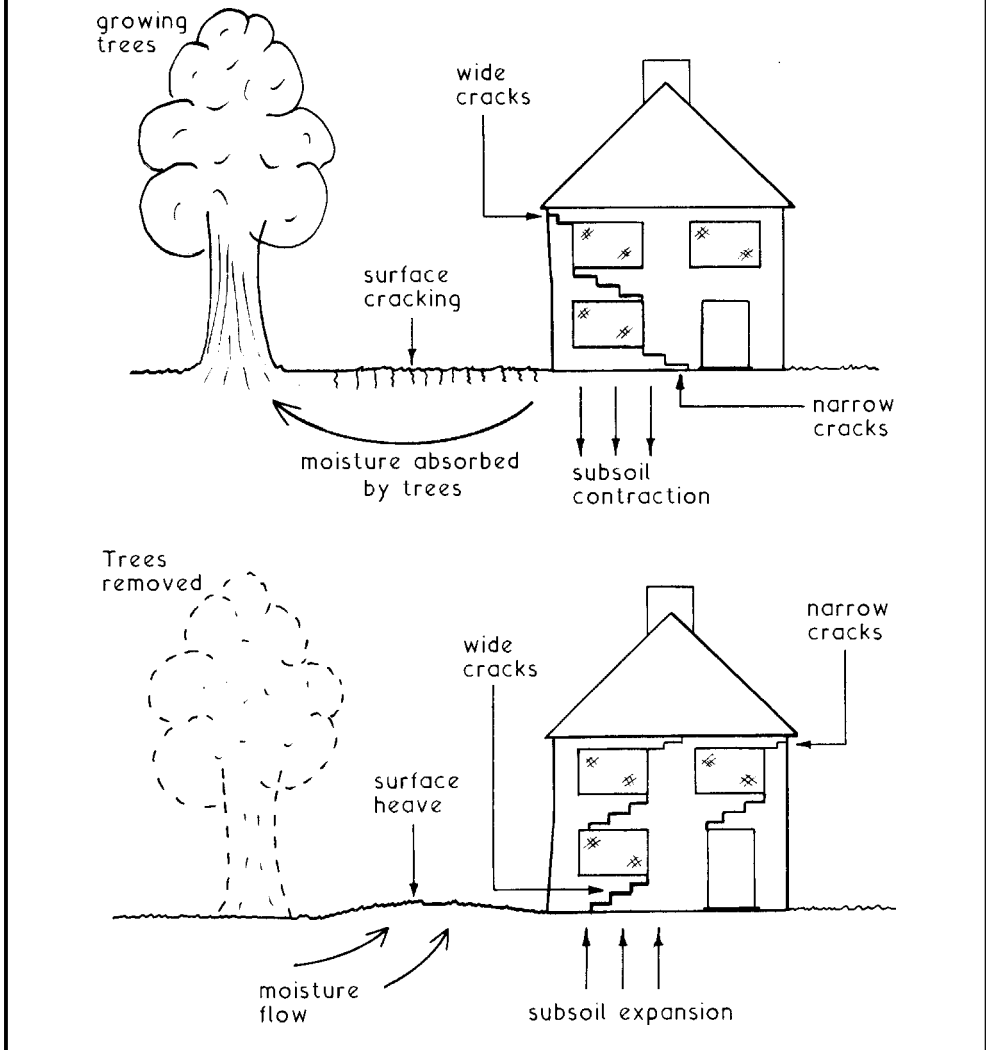

Trees ~ effect on foundations. Trees up to 30 m distance may have an effect on foundations, therefore reference to local authority building control policy should be undertaken before specifying construction techniques.

Traditional strip foundations are practically unsuited, but at excavation depths up to 2.5 or 3.0m, deep strip or trench fill (preferably reinforced) may be appropriate. Short bored pile foundations are likely to be more economical and particularly suited to depths exceeding 3.0m.

For guidance only, the illustration and table provide an indication of foundation depths in shrinkable subsoils.

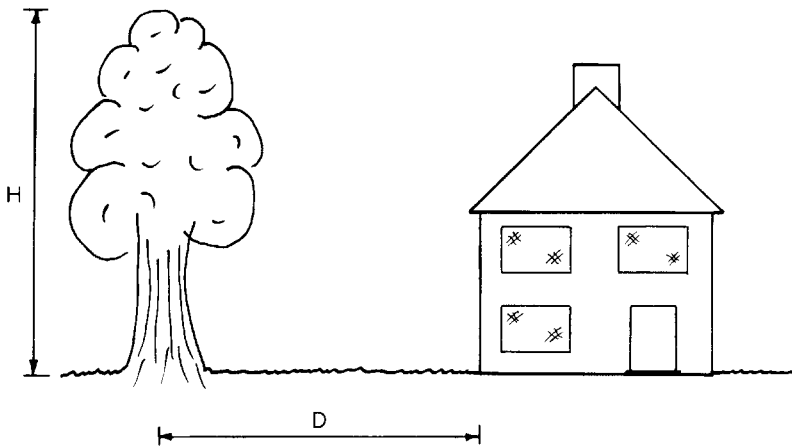

H = Mature height of tree  
 D = Distance to centre of tree

D/H - Distance from tree/Height of tree

Tree species	0.10	0.25	0.33	0.50	0.66	0.75	1.00
Oak, elm, poplar and willow	3.00	2.80	2.60	2.30	2.10	1.90	1.50
All others	2.80	2.40	2.10	1.80	1.50	1.20	1.00

Minimum foundation depth (m)

## Foundations – Subsoil Movements

Trees ~ preservation orders (see page 151) may be waived by the local planning authority. Permission for tree felling is by formal application and will be considered if the proposed development is in the economic and business interests of the community. However, tree removal is only likely to be acceptable if there is an agreement for replacement stock being provided elsewhere on the site.

In these circumstances there is potential for ground heave within the 'footprint' of felled trees. To resist this movement, foundations must incorporate an absorbing layer or compressible filler with ground floor suspended above the soil.

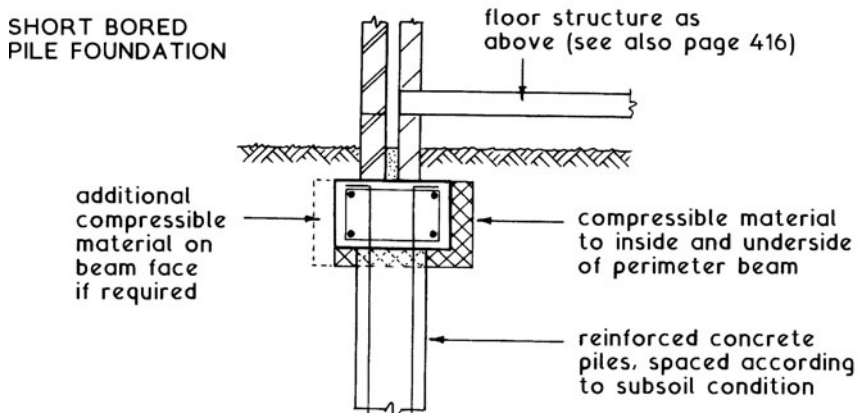
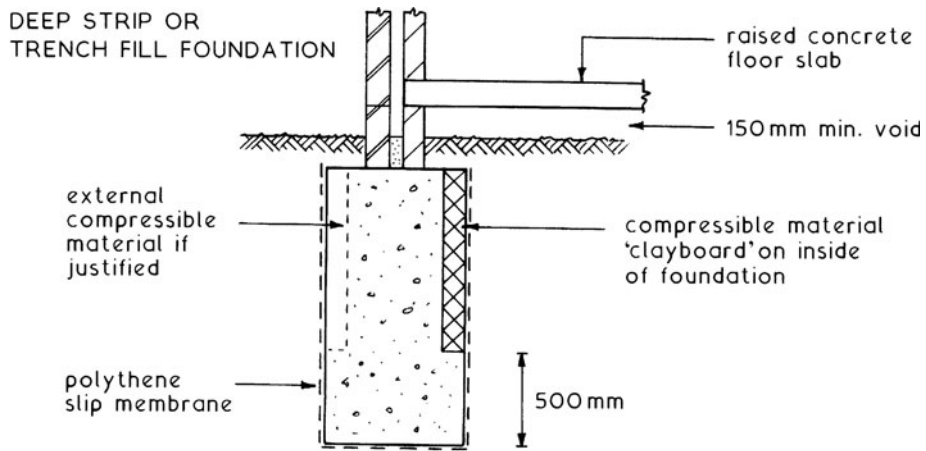

Cracking in Walls ~ cracks are caused by applied forces which exceed those that the building can withstand. Most cracking is superficial, occurring as materials dry out and subsequently shrink to reveal minor surface fractures of <math>< 2\text{ mm}</math>. These insignificant cracks can be made good with proprietary fillers.

Severe cracking in walls may result from foundation failure, due to inadequate design or physical damage. Further problems could include:

- \* Structural instability
- \* Air infiltration
- \* Sound insulation reduction
- \* Rain penetration
- \* Heat loss
- \* Visual depreciation

A survey should be undertaken to determine:

1. The cause of cracking, i.e.
  - \* Loads applied externally (tree roots, subsoil movement).
  - \* Climate/temperature changes (thermal movement).
  - \* Moisture content change (faulty dpc, building leakage).
  - \* Vibration (adjacent work, traffic).
  - \* Changes in physical composition (salt or ice formation).
  - \* Chemical change (corrosion, sulphate attack).
  - \* Biological change (timber decay).
2. The effect on a building's performance (structural and environmental).
3. The nature of movement - completed, ongoing or intermittent (seasonal).

Observations over a period of several months, preferably over a full year, will determine whether the cracking is new or established and whether it is progressing.

Simple method for monitoring cracks -

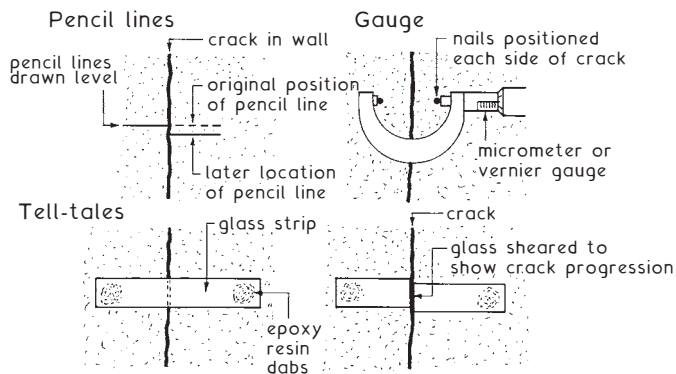

Further reading – BRE Digest 251: Assessment of damage in low rise buildings.

Foundation Materials ~ from page 244 one of the functions of a foundation can be seen to be the ability to spread its load evenly over the ground on which it rests. It must of course be constructed of a durable material of adequate strength. Experience has shown that the most suitable material is concrete.

Concrete is a mixture of cement + aggregates + water in controlled proportions.

## CEMENT

Manufactured from clay and chalk and is the matrix or binder of the concrete mix. Cement powder can be supplied in bags or bulk –

Bags ~

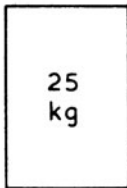

airtight sealed bags requiring a dry, damp-free store.

Bulk ~

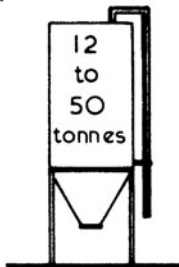

delivered by tanker and pumped into storage silo.

## AGGREGATES

Coarse aggregate is generally defined as a material which is retained on a 4mm sieve.

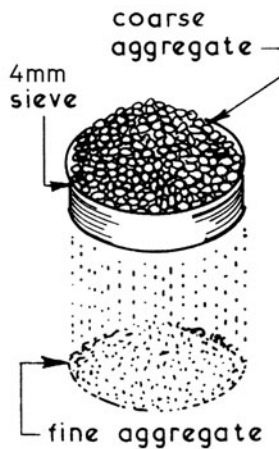

Fine aggregate is generally defined as a material which passes a 4mm sieve. Aggregates can be either natural rock which has disintegrated or crushed stone or gravel.

## WATER

Must be of a quality fit for drinking.

## MIXES

These are expressed as a ratio thus: 1:3:6/20mm which means – 1 part cement, 3 parts of fine aggregate, 6 parts of coarse aggregate. 20mm – maximum size of coarse aggregate for the mix.

Water is added to start the chemical reaction and to give the mix workability ~ the amount used is called the Water/Cement Ratio and is usually about 0.4 to 0.5.

Too much water will produce a weak concrete of low strength whereas too little water will produce a concrete mix of low and inadequate workability.

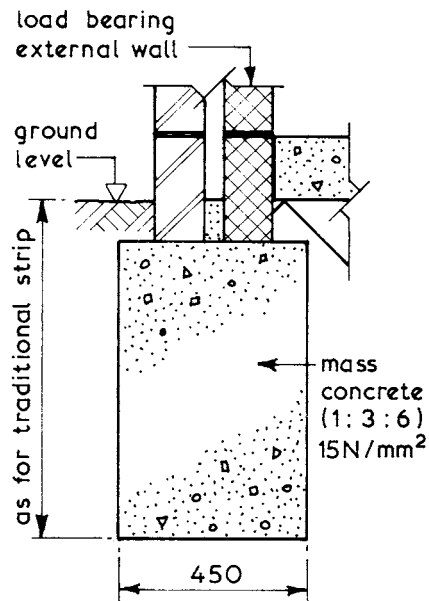
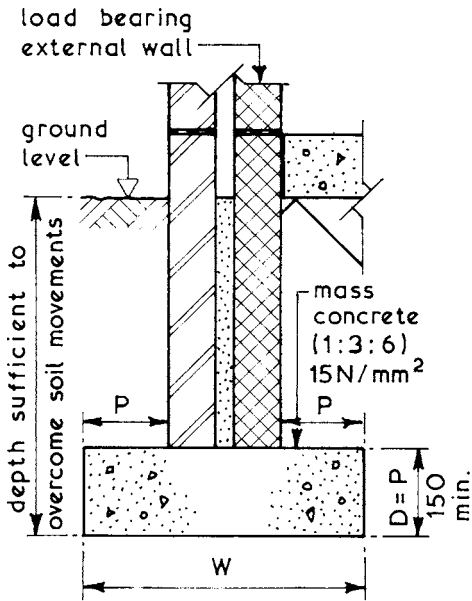

$$W = \frac{\text{load per metre}}{\text{bearing capacity of soil or}}$$

W = not less than that given in Table on page 255

NB. In all cases W must give adequate working space which is usually 450 to 600 mm minimum depending on depth of excavation.

generally considered to be cheaper than traditional strip foundations since:

1. fewer man hours required.
2. requires less skilled trades.
3. uses ready-mix concrete, therefore less material is stored on site making it clearer and easier to manage.

TRADITIONAL STRIP

DEEP STRIP OR TRENCH FILL

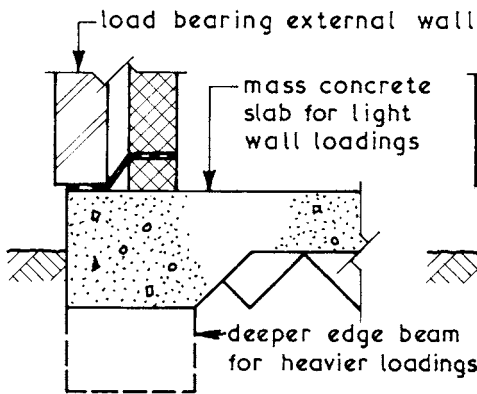

SOLID SLAB RAFT

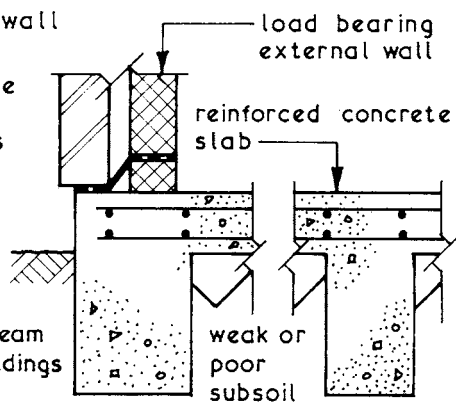

BEAM AND SLAB RAFT



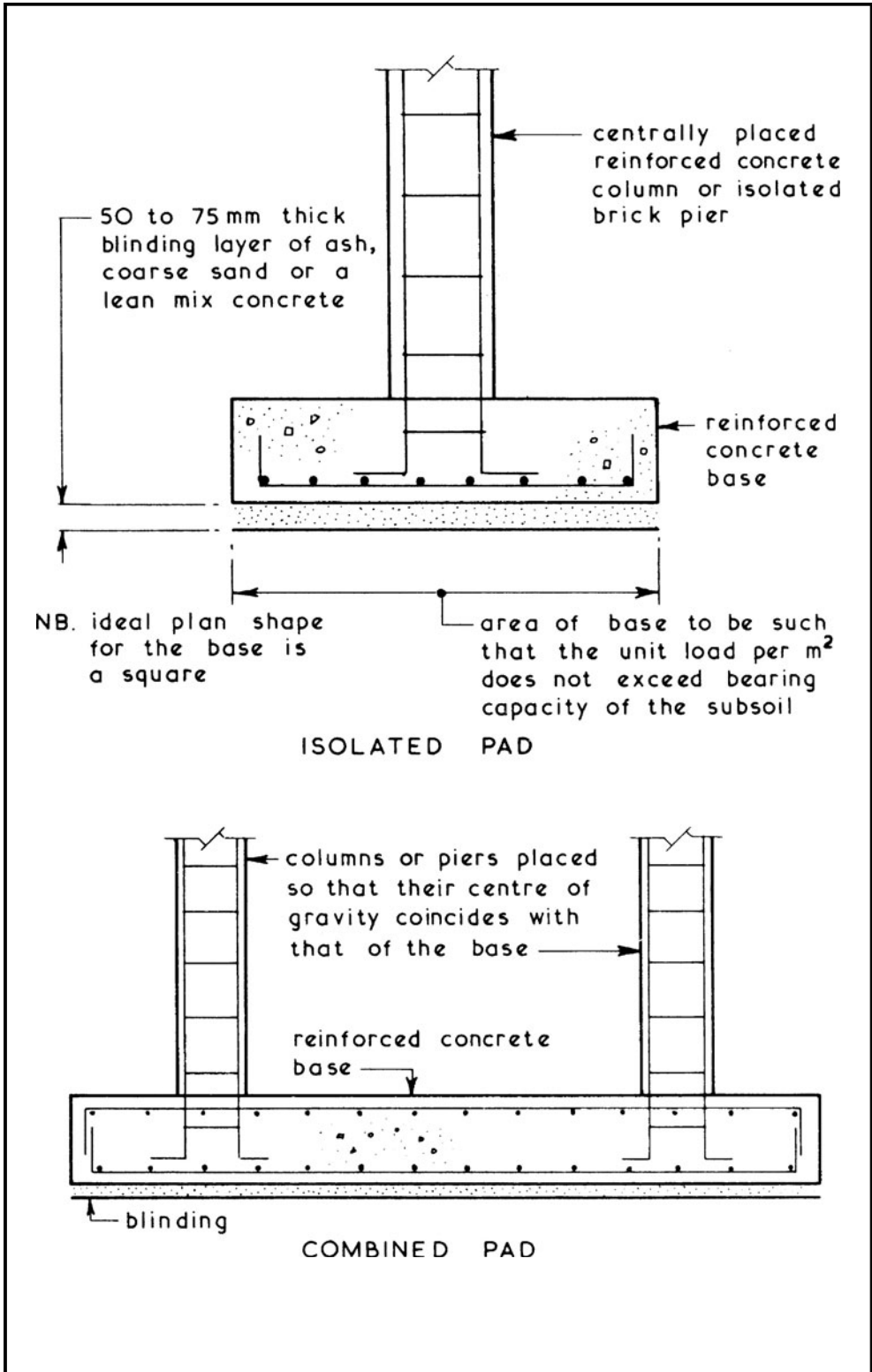

Bed ~ a concrete slab resting on and supported by the subsoil, usually forming the ground floor surface. Beds (sometimes called over-site concrete) are usually cast on a layer of hardcore which is used to make up the reduced level excavation and thus raise the level of the concrete bed to a position above ground level.

Typical Example ~

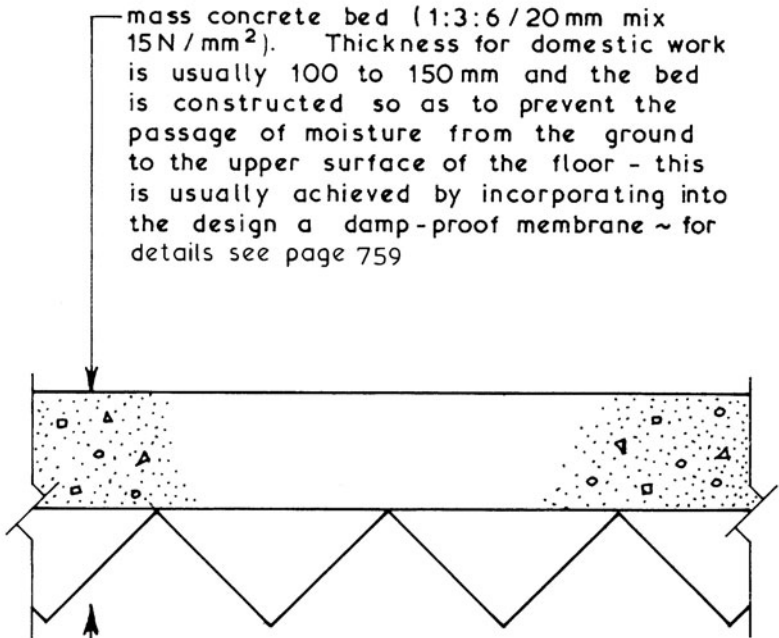

mass concrete bed (1:3:6/20mm mix  $15\text{N/mm}^2$ ). Thickness for domestic work is usually 100 to 150mm and the bed is constructed so as to prevent the passage of moisture from the ground to the upper surface of the floor - this is usually achieved by incorporating into the design a damp-proof membrane ~ for details see page 759

100 to 150mm-thick layer of hardcore ~ material used should be inert and not affected by water. Suitable materials are gravel; crushed rock; quarry waste; concrete rubble; brick or tile rubble; blast furnace slag and pulverised fuel ash (fly ash). The hardcore material should be laid evenly and well compacted with the upper surface blinded with fine grade material such as sand. Sand blinding fills the gaps in the hardcore to prevent concrete wastage and to provide a relatively smooth and level surface for a 0.3mm LDPE (1200 gauge polythene) dpm where required.

## Foundations – Basic Sizing

Basic Sizing ~ the size of a foundation is basically dependent on two factors:

1. Load being transmitted, max 70kN/m (dwellings up to three storeys).
2. Bearing capacity of subsoil under proposed foundation.

For guidance on bearing capacities for different types of subsoil see BS EN 1997-1: Geotechnical design. General rules and BS 8103-1: Structural design of low rise buildings. Also, directly from soil investigation results.

Typical Examples ~

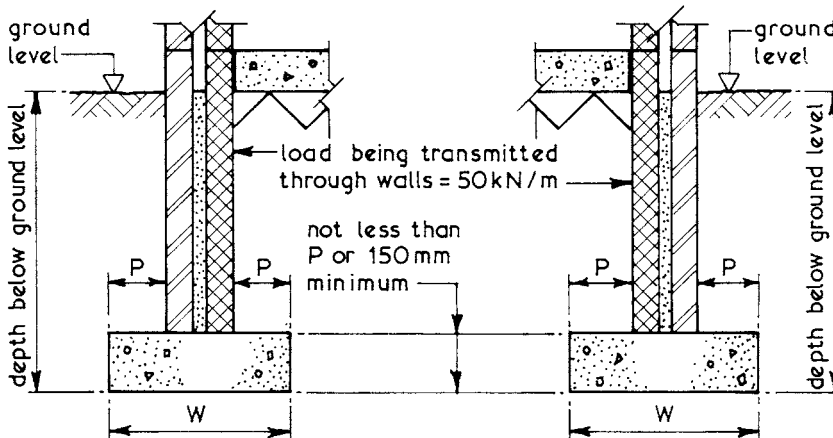

safe bearing capacity of compact gravel subsoil =  $100 \text{ kN/m}^2$

$$W = \frac{\text{load}}{\text{bearing capacity}} = \frac{50}{100} = 500\text{mm minimum}$$

safe bearing capacity of clay subsoil =  $80 \text{ kN/m}^2$

$$W = \frac{\text{load}}{\text{bearing capacity}} = \frac{50}{80} = 625\text{mm minimum}$$

The above widths may not provide adequate working space within the excavation and can be increased to give required space.

Guidance on the minimum width for a limited range of applications can be taken from the table on the next page.

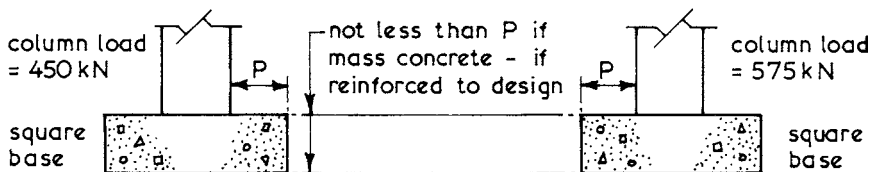

bearing capacity of subsoil  $150 \text{ kN/m}^2$

$$\text{area of base} = \frac{\text{load}}{bc} = \frac{450}{150}$$

$$= 3 \text{ m}^2 \therefore \text{side} = \sqrt{3} = 1.732 \text{ min.}$$

bearing capacity of subsoil  $85 \text{ kN/m}^2$

$$\text{area of base} = \frac{\text{load}}{bc} = \frac{575}{85}$$

$$= 6.765 \text{ m}^2 \therefore \text{side} = \sqrt{6.765} = 2.6 \text{ min.}$$

## Guide to Strip Foundation Width

Ground type	Ground condition	Field test	Max. total load on load-bearing wall (kN/m)					
			20	30	40	50	60	70
			Minimum width (mm)					
Rock	Not inferior to sandstone, limestone or firm chalk	Requires a mechanical device to excavate.	At least equal to the width of the wall					
Gravel	Medium density	Pick required to excavate.						
Sand	Compact	50 mm square peg hard to drive beyond 150 mm.	250	300	400	500	600	650
Clay	Stiff	Requires pick or mechanical device to aid removal. Can be indented slightly with thumb.						
Sandy clay	Stiff		250	300	400	500	600	650
Clay	Firm	Can be moulded under substantial pressure by fingers.						
Sandy clay	Firm		300	350	450	600	750	850
Sand	Loose	Can be excavated by spade. 50 mm square peg easily driven.						
Silty sand	Loose							
Clayey sand	Loose		400	600	Conventional strip foundations unsuitable for a total load exceeding 30 kN/m			
Silt	Soft	Finger pushed in up to 10 mm. Easily moulded with fingers.						
Clay	Soft		450	650				
Sandy clay	Soft							
Silty clay	Soft							
Silt	Very soft	Finger easily pushed in up to 25 mm. Wet sample exudes between fingers when squeezed.	Conventional strip inappropriate.					
Clay	Very soft		Steel-reinforced wide strip, deep strip or piled foundation selected subject to specialist advice					
Sandy clay	Very soft							
Silty clay	Very soft							

Adapted from Table 10 in the Bldg. Regs., A.D: A - Structure.

## Foundations – Calculated Sizing

Typical Procedure (for guidance only) -

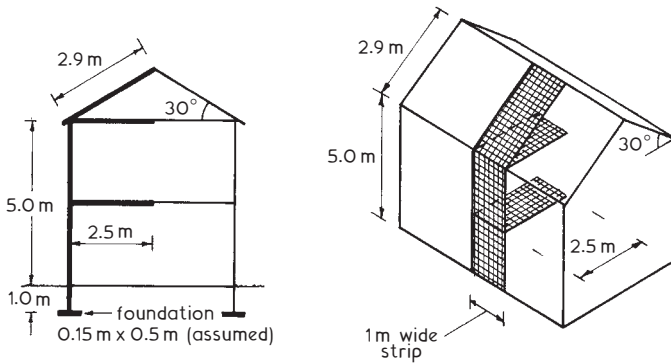

Dead load per m run (see pages 38 and 39)		
Substructure brickwork, 1 m × 1 m × 476 kg/m <sup>3</sup>	=	476 kg
..... cavity conc. (50 mm), 1 m × 1 m × 2300 kg/m <sup>3</sup>	=	115 kg
Foundation concrete, 0.15 m × 1 m × 0.5 m × 2300 kg/m <sup>3</sup>	=	173 kg
Superstructure brickwork, 5 m × 1 m × 221 kg/m <sup>2</sup>	=	1105 kg
..... blockwork & ins., 5 m × 1 m × 79 kg/m <sup>2</sup>	=	395 kg
..... 2 coat plasterwork, 5 m × 1 m × 22 kg/m <sup>2</sup>	=	110 kg
Floor joists/boards/plstrbrd., 2.5 m × 1 m × 42.75 kg/m <sup>2</sup>	=	107 kg
Ceiling joists/plstrbrd/ins., 2.5 m × 1 m × 19.87 kg/m <sup>2</sup>	=	50 kg
Rafters, battens & felt, 2.9 m × 1 m × 12.10 kg/m <sup>2</sup>	=	35 kg
Single lap tiling, 2.9 m × 1 m × 49 kg/m <sup>2</sup>	=	142 kg
		<hr/>
		2708 kg

Note: kg × 9.81 = Newtons

Therefore: 2708 kg × 9.81 = 26565 N or 26.56 kN

Imposed load per m run (see BS EN 1991-1-1: Densities, self-weight, imposed loads for buildings) -

Floor, 2.5 m × 1 m × 1.5 kN/m<sup>2</sup> = 3.75 kN

Roof, 2.9 m × 1 m × 1.5 kN/m<sup>2</sup> (snow) = 4.05 kN

7.80 kN

Note: For roof pitch >30°, snow load = 0.75 kN/m<sup>2</sup>

Dead + imposed load is 26.56 kN + 7.80 kN = 34.36 kN

Given that the subsoil has a safe bearing capacity of 75 kN/m<sup>2</sup>,

W = load ÷ bearing capacity = 34.36 ÷ 75 = 0.458 m or 458 mm

Therefore a foundation width of 500 mm is adequate.

Note: This example assumes the site is sheltered. If it is necessary to make allowance for wind loading, reference should be made to BS EN 1991-1-4: Wind actions.

Stepped Foundations ~ these are usually considered in the context of strip foundations and are used mainly on sloping sites to reduce the amount of excavation and materials required to produce an adequate foundation.

Comparison ~

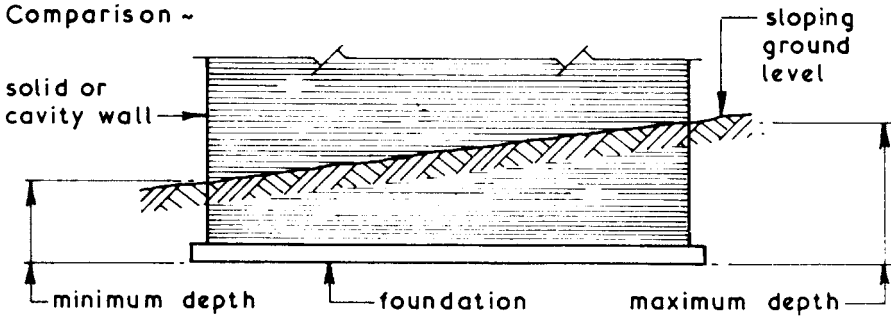

LEVEL FOUNDATION

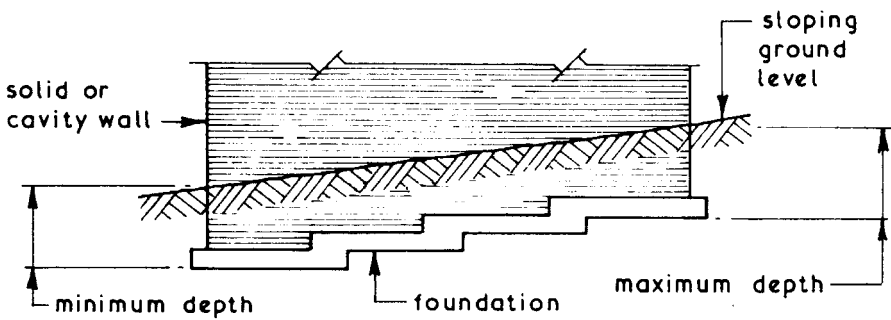

STEPPED FOUNDATION

Typical Details ~

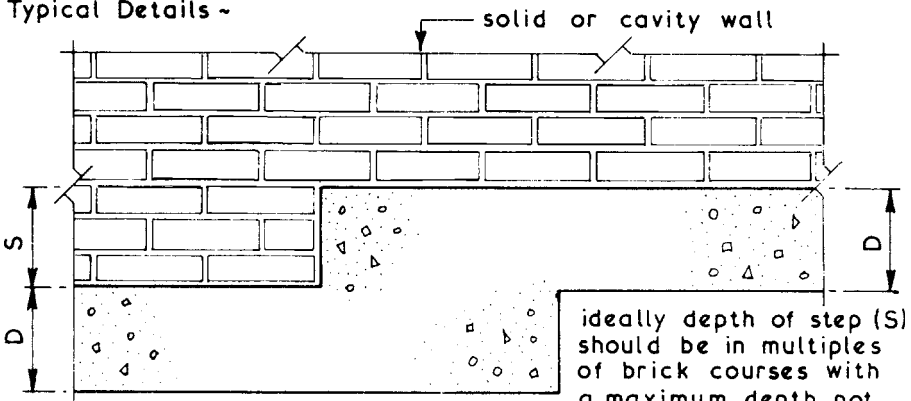

minimum overlap (L) =  $2 \times S$ ; D or 300mm whichever is the greater

ideally depth of step (S) should be in multiples of brick courses with a maximum depth not greater than D

# Simple RC Foundations

Concrete Foundations ~ concrete is a material which is strong in compression but weak in tension. If its tensile strength is exceeded cracks will occur, resulting in a weak and unsuitable foundation. One method of providing tensile resistance is to include in the concrete foundation bars of steel as a form of reinforcement to resist all the tensile forces induced into the foundation. Steel is a material which is readily available and has high tensile strength.

## Comparisons ~

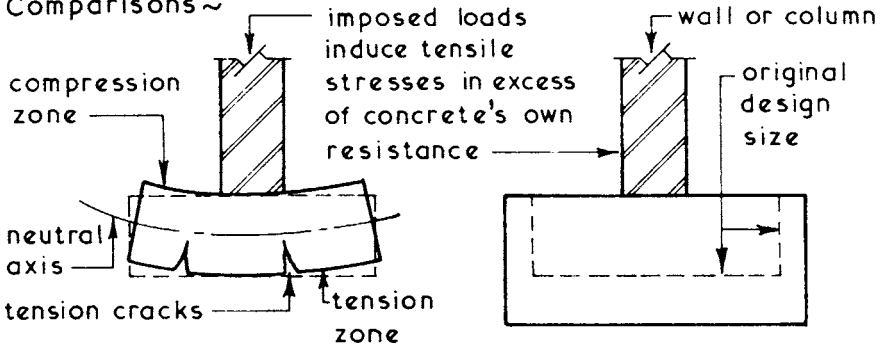

foundation tends to bend, the upper fibres being compressed and the lower fibres being stretched and put in tension - remedies: increase size of base or design as a reinforced concrete foundation

size of foundation increased to provide the resistance against the induced tensile stresses - generally not economic due to the extra excavation and materials required

## Typical RC Foundation

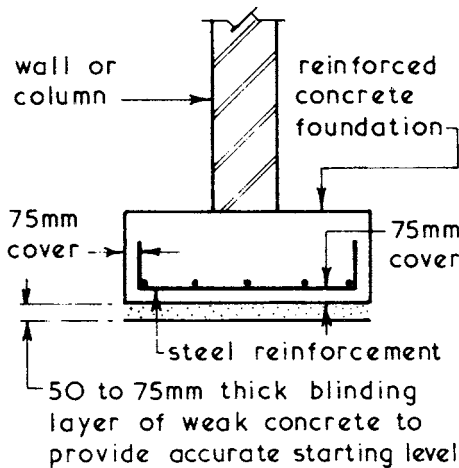

## Reinforcement Patterns distribution

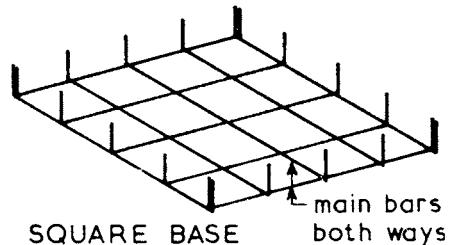
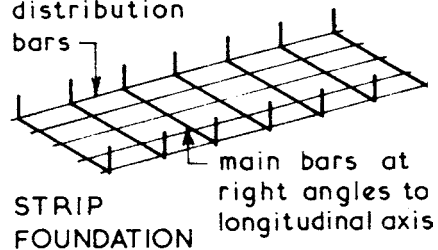

## Short Bored Pile Foundations

Short Bored Piles ~ these are a form of foundation which are suitable for domestic loadings and clay subsoils where ground movements can occur below the 1.000 depth associated with traditional strip and trench fill foundations. They can be used where trees are planted close to a new building since the trees may eventually cause damaging ground movements due to extracting water from the subsoil and root growth. Conversely where trees have been removed this may lead to ground swelling.

Typical Details ~

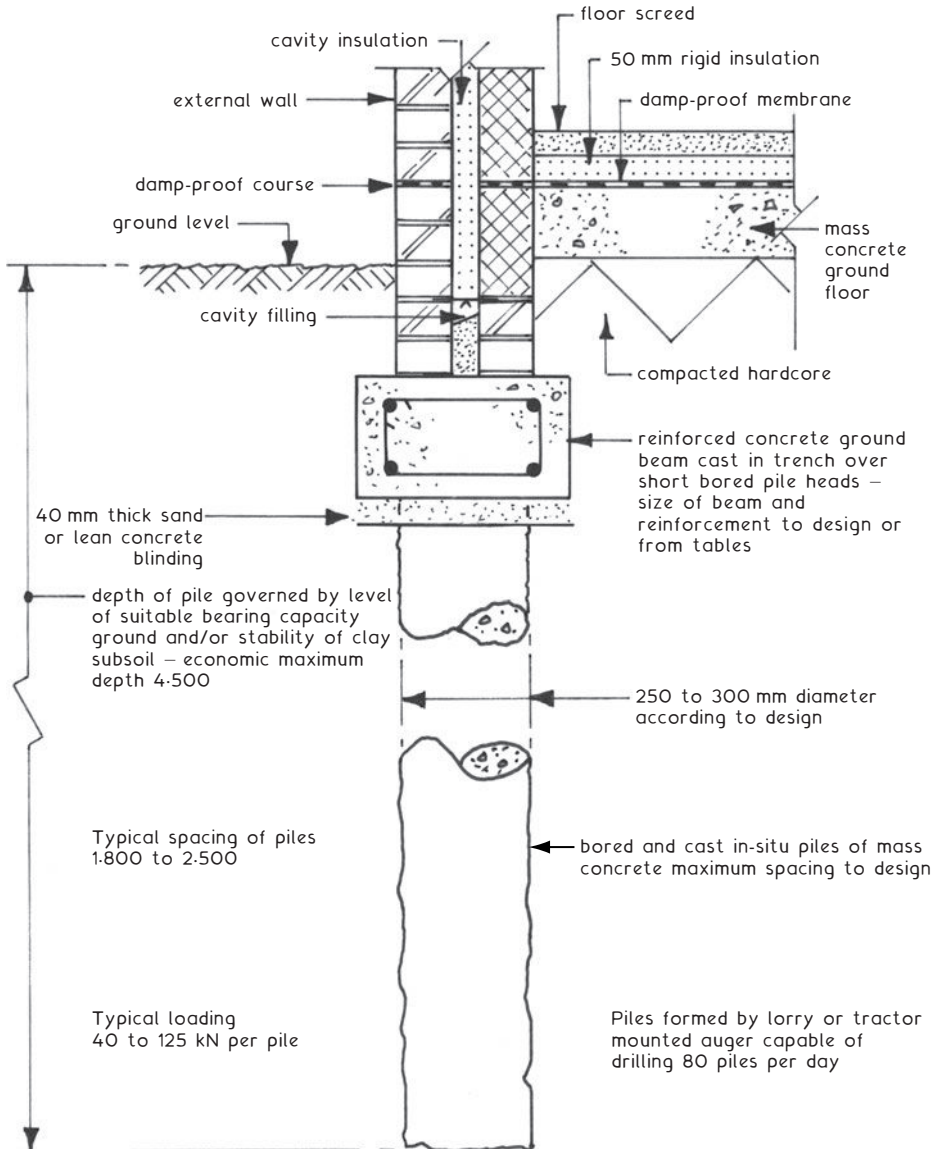



# Simple RC Raft Foundations

Simple Raft Foundations ~ these can be used for lightly loaded buildings on poor soils or where the top 450 to 600 mm of soil is overlaying a poor-quality substrata.

Typical Details ~

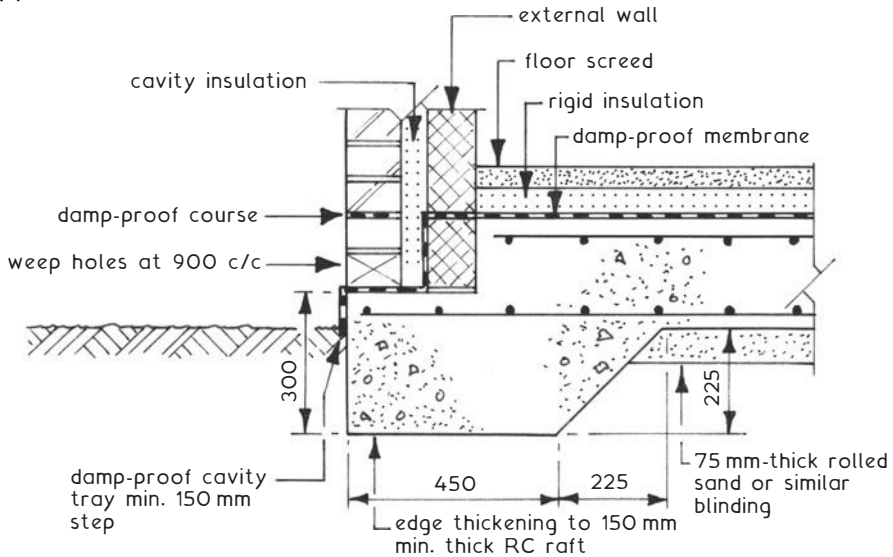

## REINFORCED CONCRETE RAFT WITH EDGE THICKENING

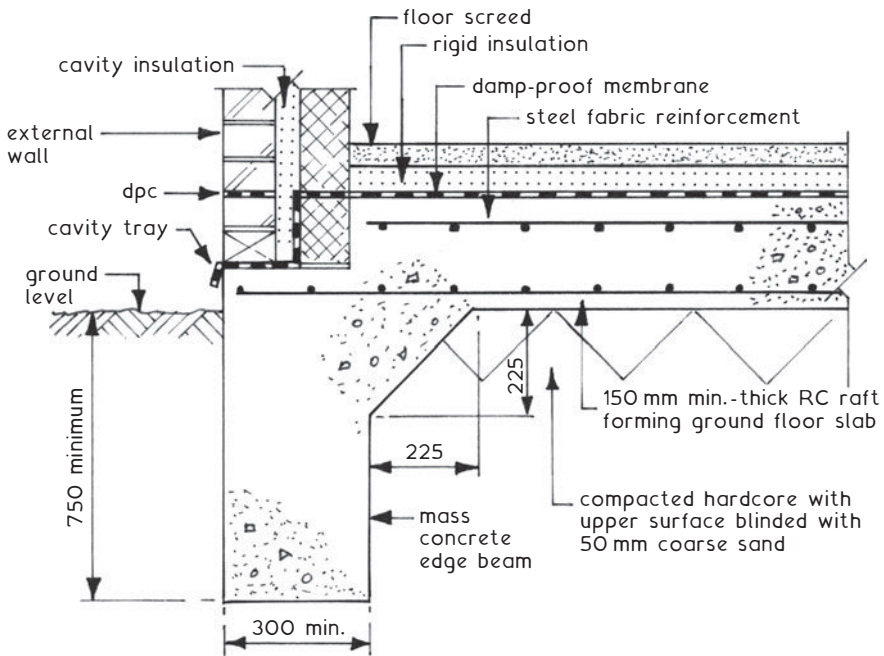

## REINFORCED CONCRETE RAFT WITH EDGE BEAM

Foundation Design Principles ~ the main objectives of foundation design are to ensure that the structural loads are transmitted to the subsoil(s) safely, economically and without any unacceptable movement during the construction period and throughout the anticipated life of the building or structure.

Basic Design Procedure ~ this can be considered as a series of steps or stages:

1. Assessment of site conditions in the context of the site and soil investigation report.
2. Calculation of anticipated structural loading(s).
3. Choosing the foundation type taking into consideration:
  - Soil conditions;
  - Type of structure;
  - Structural loading(s);
  - Economic factors;
  - Time factors relative to the proposed contract period;
  - Construction problems.
4. Sizing the chosen foundation in the context of loading(s), ground bearing capacity and any likely future movements of the building or structure.

Foundation Types ~ apart from simple domestic foundations most foundation types are constructed in reinforced concrete and may be considered as being shallow or deep. Most shallow types of foundation are constructed within 2·000 of the ground level but in some circumstances it may be necessary to take the whole or part of the foundations down to a depth of 2·000 to 5·000 as in the case of a deep basement where the structural elements of the basement are to carry the superstructure loads. Generally foundations which need to be taken below 5·000 deep are cheaper when designed and constructed as piled foundations and such foundations are classified as deep foundations. (For piled foundation details see pages 266 to 286.)

Foundations are usually classified by their type such as strips, pads, rafts and piles. It is also possible to combine foundation types such as strip foundations connected by beams to and working in conjunction with pad foundations.

# Foundation Types and Selection

Strip Foundations ~ these are suitable for most subsoils and light structural loadings such as those encountered in low to medium rise domestic dwellings where mass concrete can be used. Reinforced concrete is usually required for all other situations.

## Typical Strip Foundation Types ~

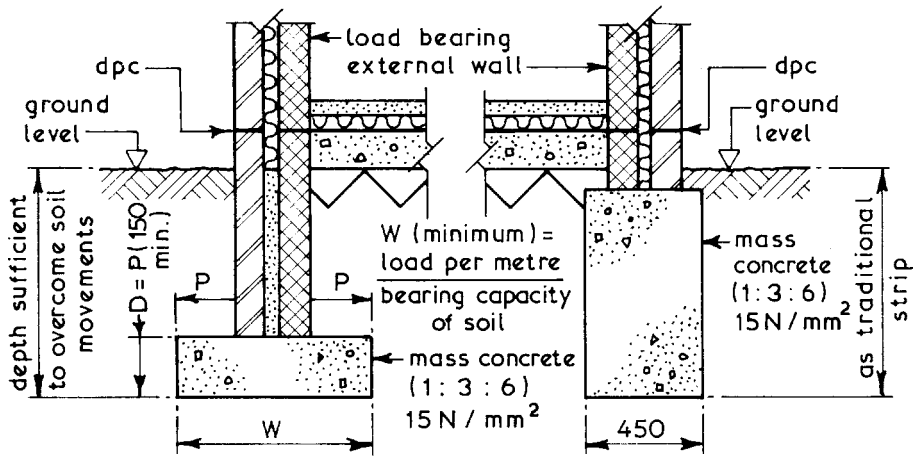

**TRADITIONAL STRIP**  
low rise domestic dwellings  
or similar buildings

**DEEP STRIP or TRENCH FILL**  
alternative to traditional strip

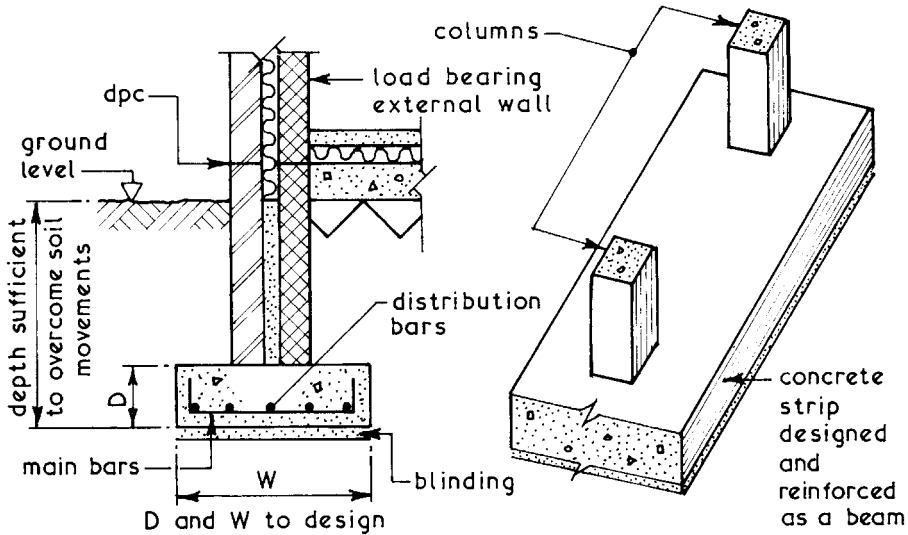

**REINFORCED CONCRETE STRIP**  
used where induced tension exceeds  
concrete's own tensile resistance

**CONTINUOUS COLUMN**  
used for closely spaced or  
close to boundary columns

Pad Foundations ~ suitable for most subsoils except loose sands, loose gravels and filled areas. Pad foundations are usually constructed of reinforced concrete and where possible are square in plan.

Typical Pad Foundation Types ~

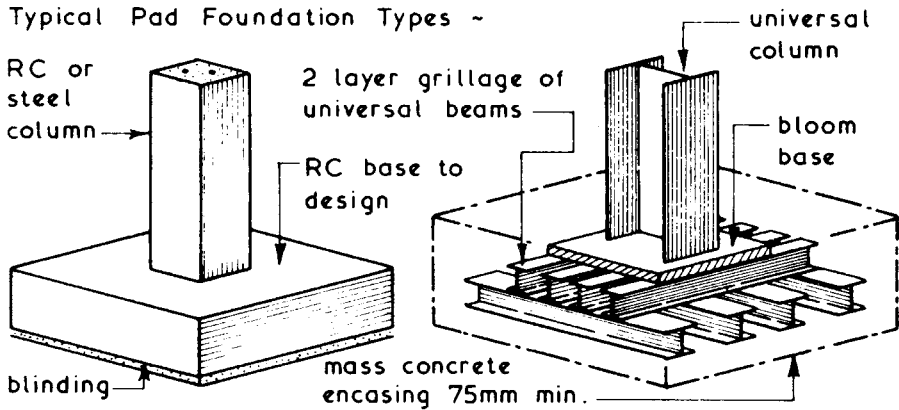

**ISOLATED or PAD FOUNDATION**  
 designed to span in two directions therefore main bars are placed in the bottom both ways

**STEEL GRILLAGE**  
 used for heavy concentrated loads - seldom employed today

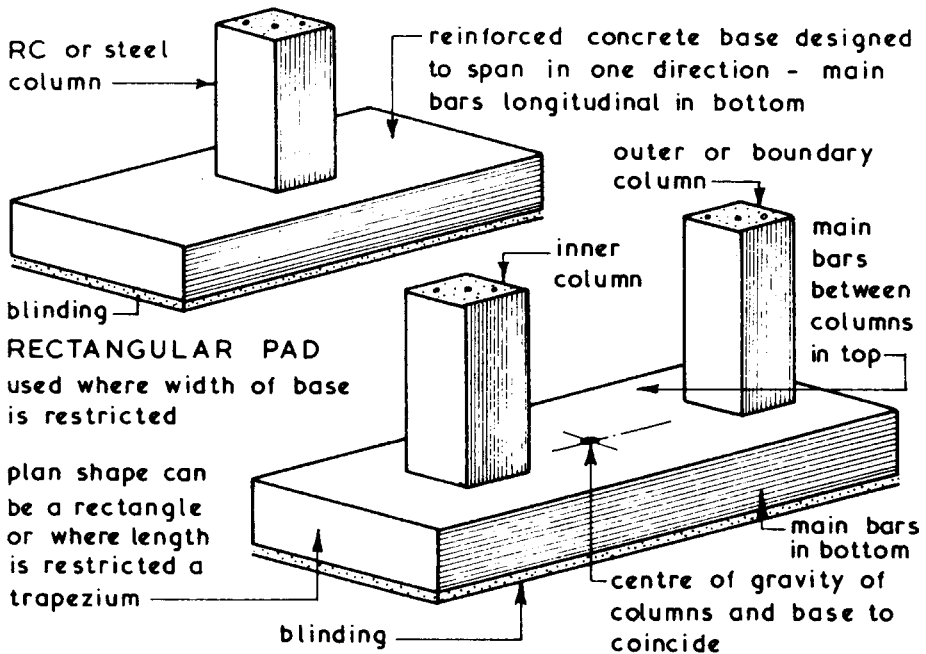

# Foundation Types and Selection

Raft Foundations ~ these are used to spread the load of the superstructure over a large base to reduce the load per unit area being imposed on the ground and this is particularly useful where low bearing capacity soils are encountered and where individual column loads are heavy.

Typical Raft Foundation Types ~

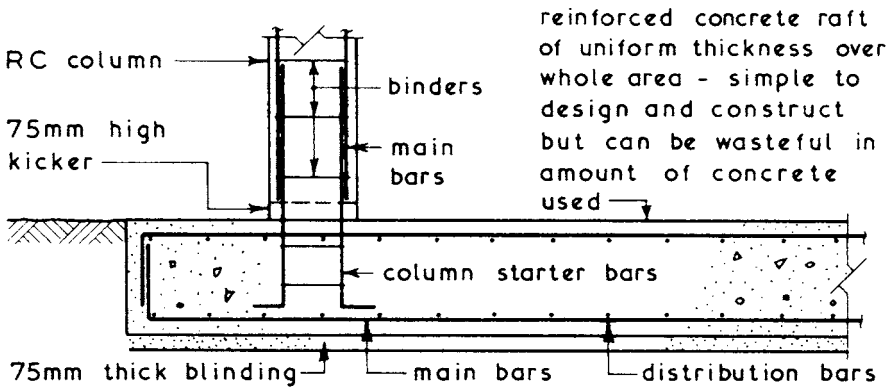

SOLID SLAB RAFT

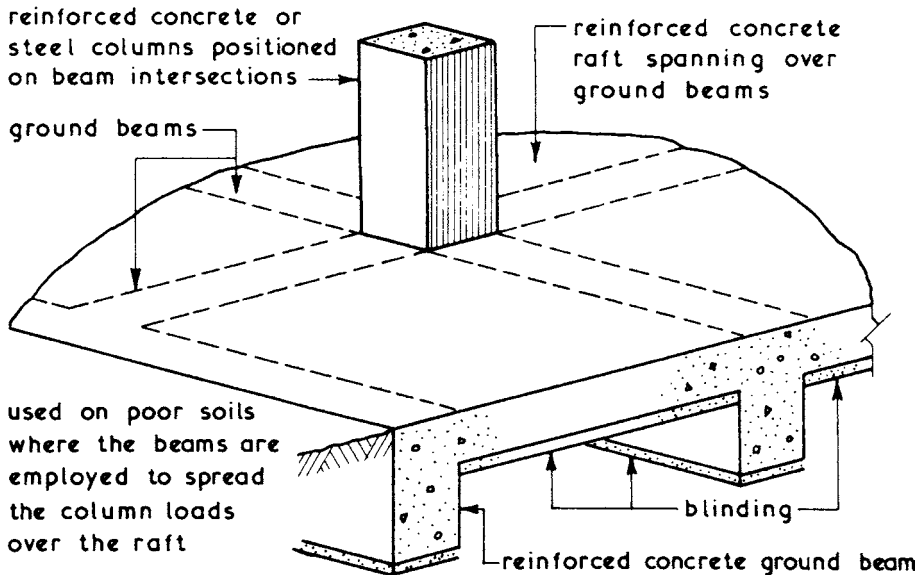

NB. Ground beams can be designed as upstand beams with a precast concrete suspended floor at ground level thus creating a void space between raft and ground floor.

BEAM AND SLAB RAFT

Cantilever Foundations ~ these can be used where it is necessary to avoid imposing any pressure on an adjacent foundation or underground service.

## Typical Cantilever Foundation Types ~

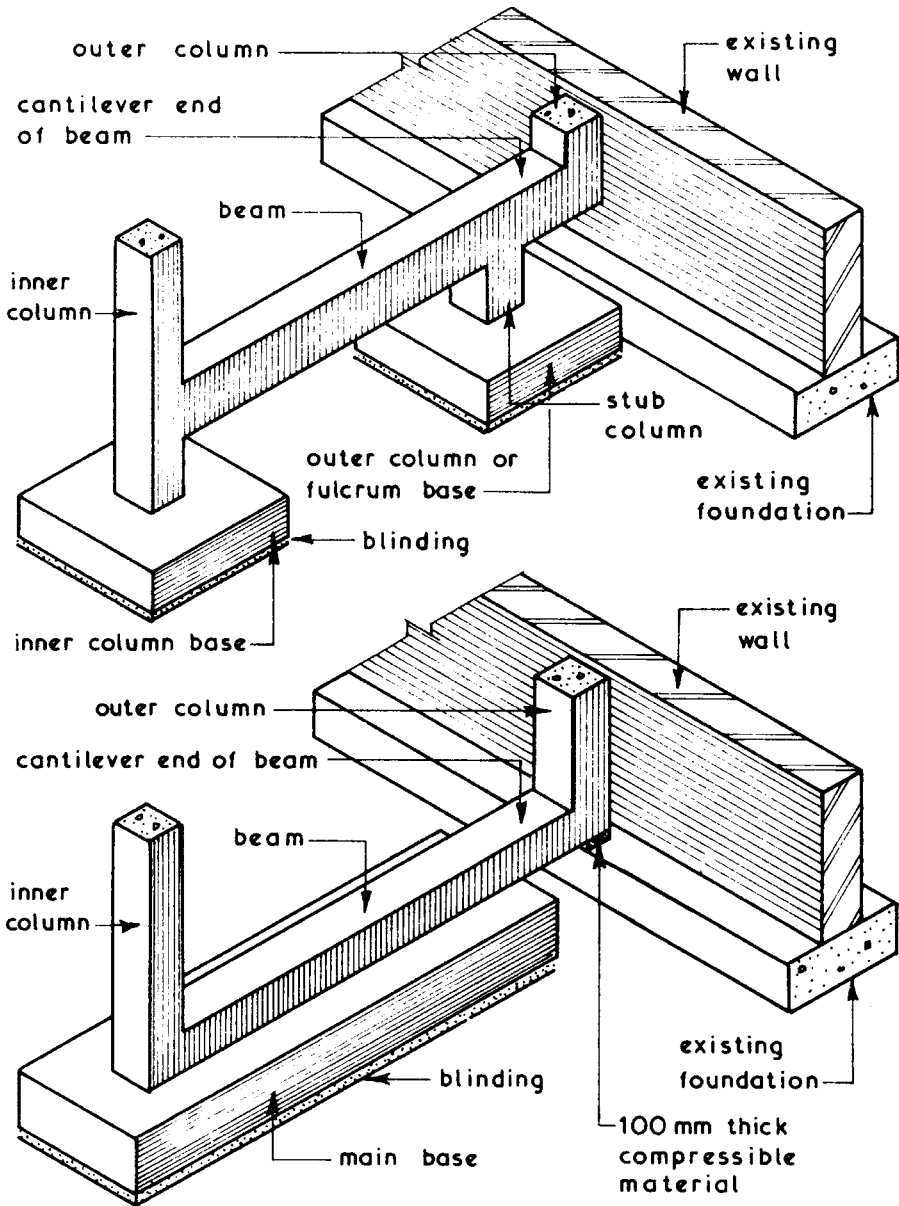

Cantilever foundations designed and constructed in reinforced concrete

# Piled Foundations

Piled Foundations ~ these can be defined as a series of columns constructed or inserted into the ground to transmit the load(s) of a structure to a lower level of subsoil. Piled foundations can be used when suitable foundation conditions are not present at or near ground level making the use of deep traditional foundations uneconomic. The lack of suitable foundation conditions may be caused by:

1. Natural low bearing capacity of subsoil.
2. High water table - giving rise to high permanent dewatering costs.
3. Presence of layers of highly compressible subsoils such as peat and recently placed filling materials which have not sufficiently consolidated.
4. Subsoils which may be subject to moisture movement or plastic failure.

Classification of Piles ~ piles may be classified by their basic design function or by their method of construction:

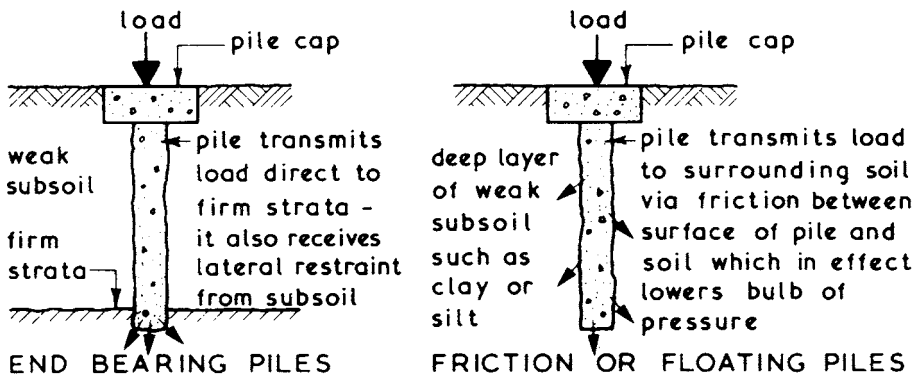

NB. Piles can work in a combination of the above design functions

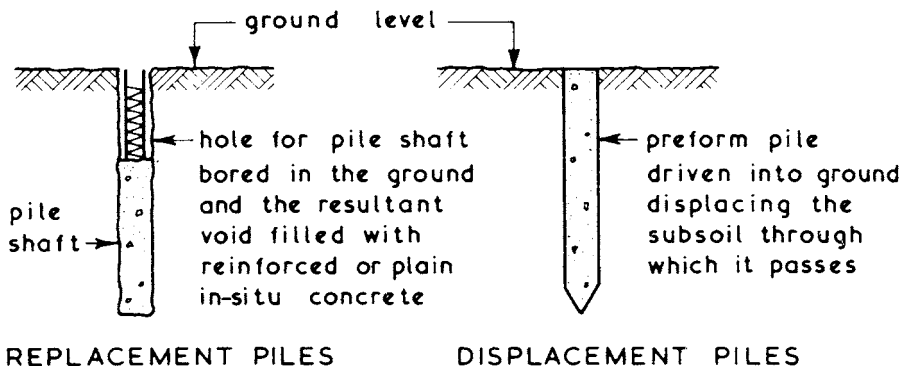

Replacement Piles ~ these are often called bored piles since the removal of the spoil to form the hole for the pile is always carried out by a boring technique. They are used primarily in cohesive subsoils for the formation of friction piles and when forming pile foundations close to existing buildings where the allowable amount of noise and/or vibration is limited.

Replacement Pile Types ~

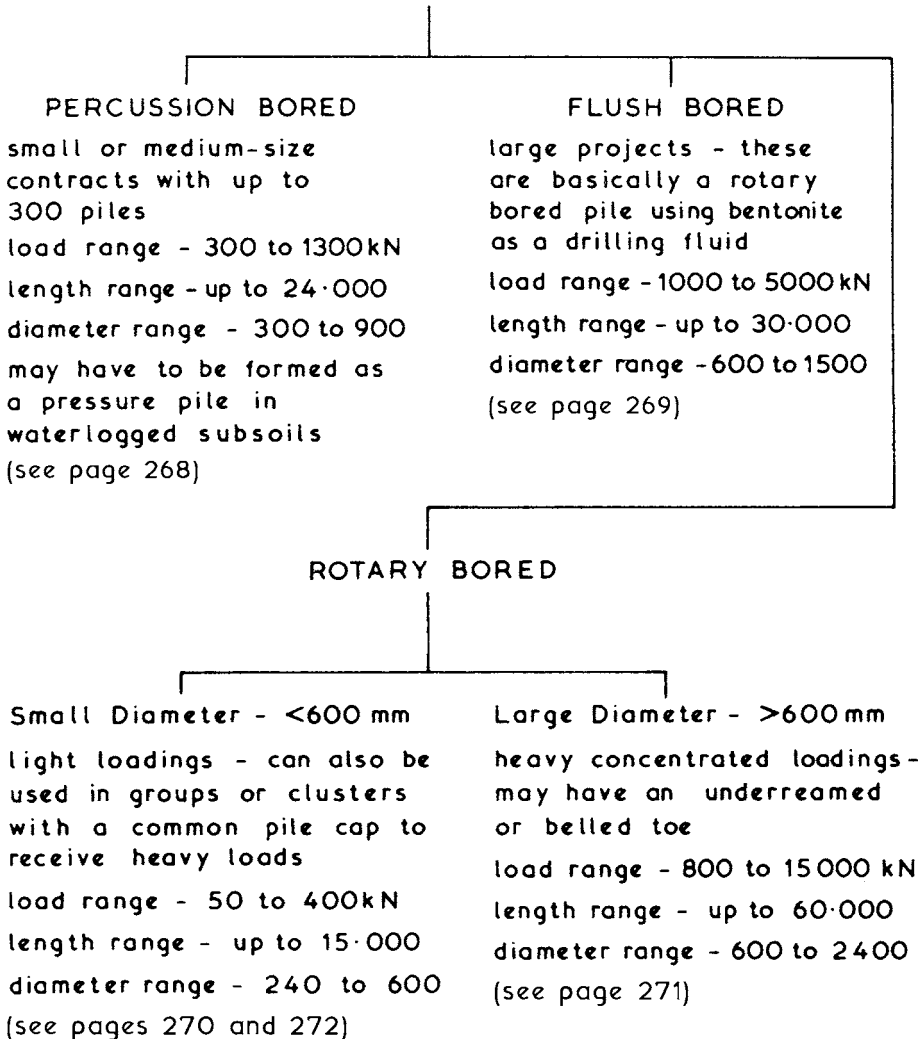

NB. The above given data depicts typical economic ranges.  
More than one pile type can be used on a single contract.



# Piled Foundations

## Percussion Bored Piles

### Typical Details ~

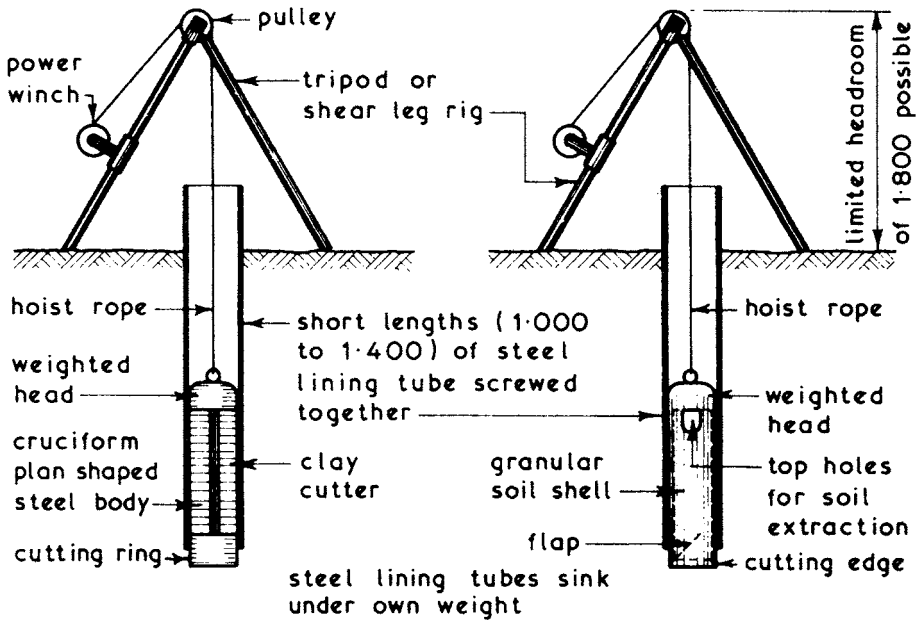

BORING IN COHESIVE SOIL

BORING IN GRANULAR SOIL

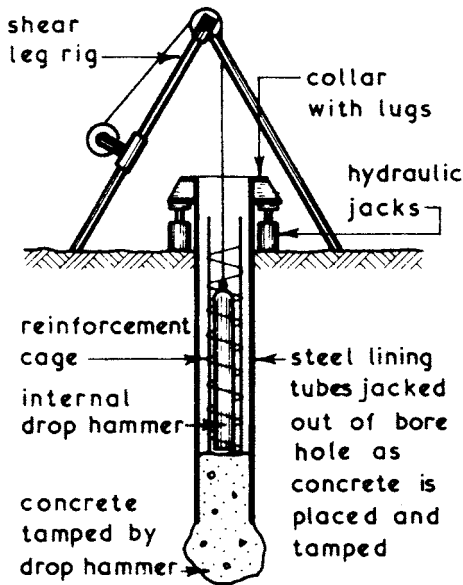

FORMING PILE USING DROP HAMMER

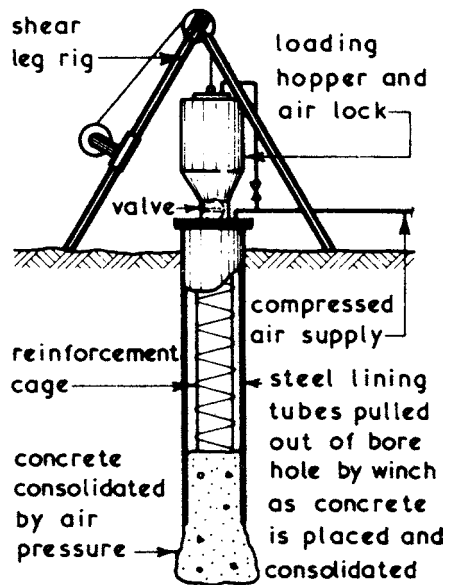

FORMING PILE USING AIR PRESSURE

Flush Bored Piles

Typical Details -

Stage 1

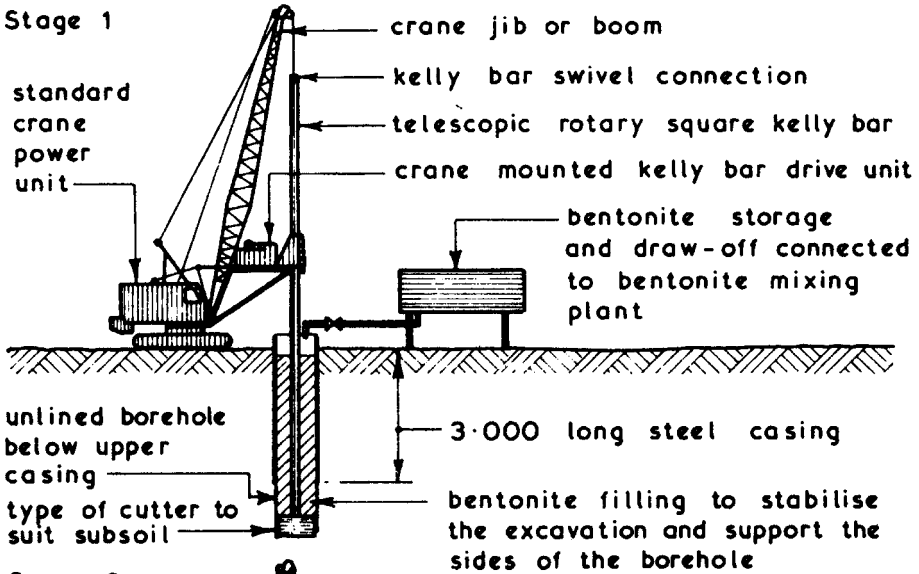

Stage 2

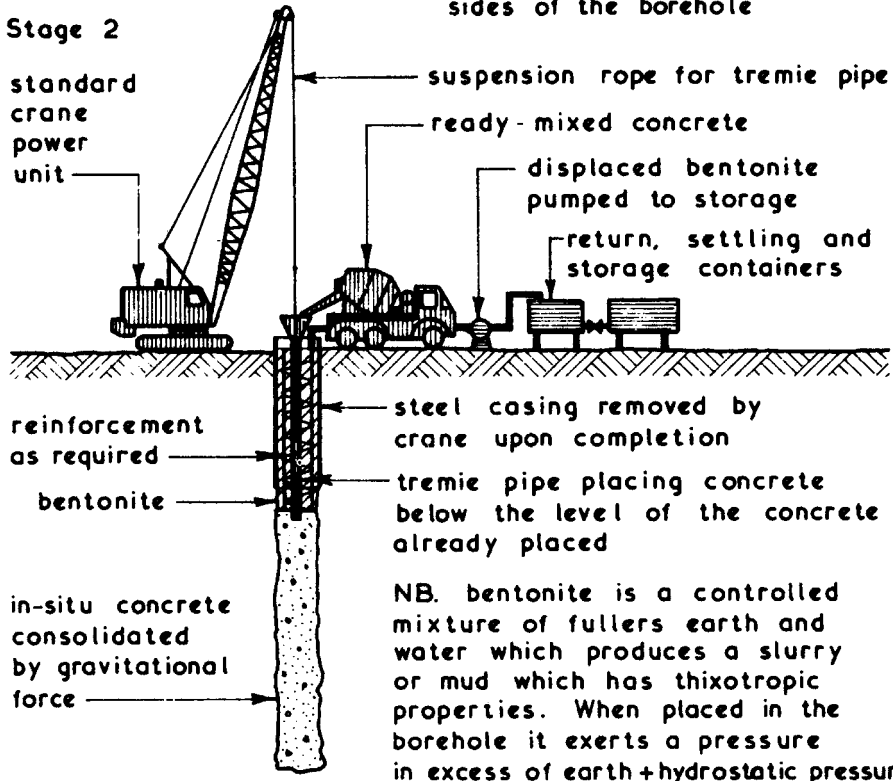

# Piled Foundations

## Small Diameter Rotary Bored Piles

### Typical Details ~

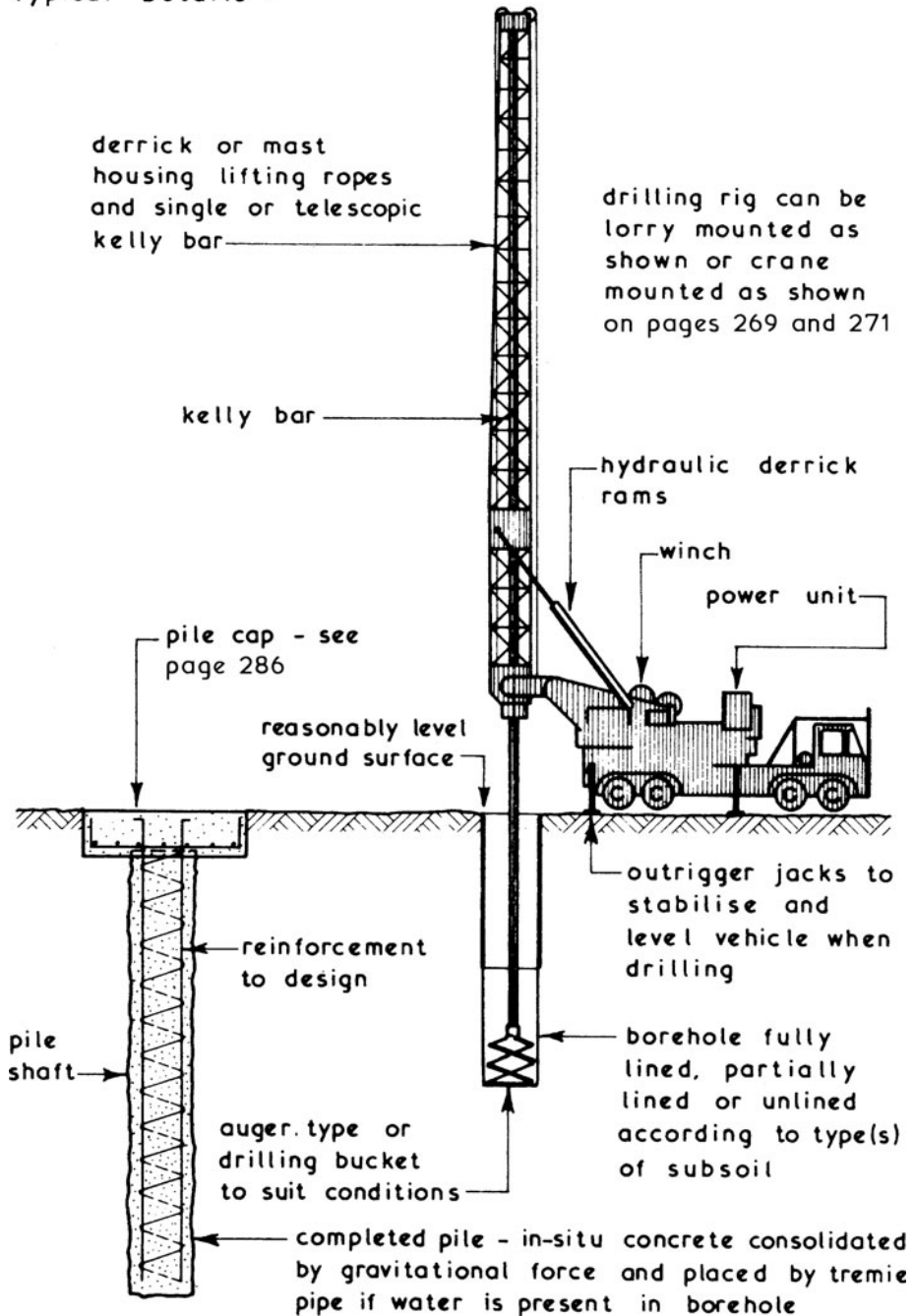

Large Diameter Rotary Bored Piles

Typical Details ~

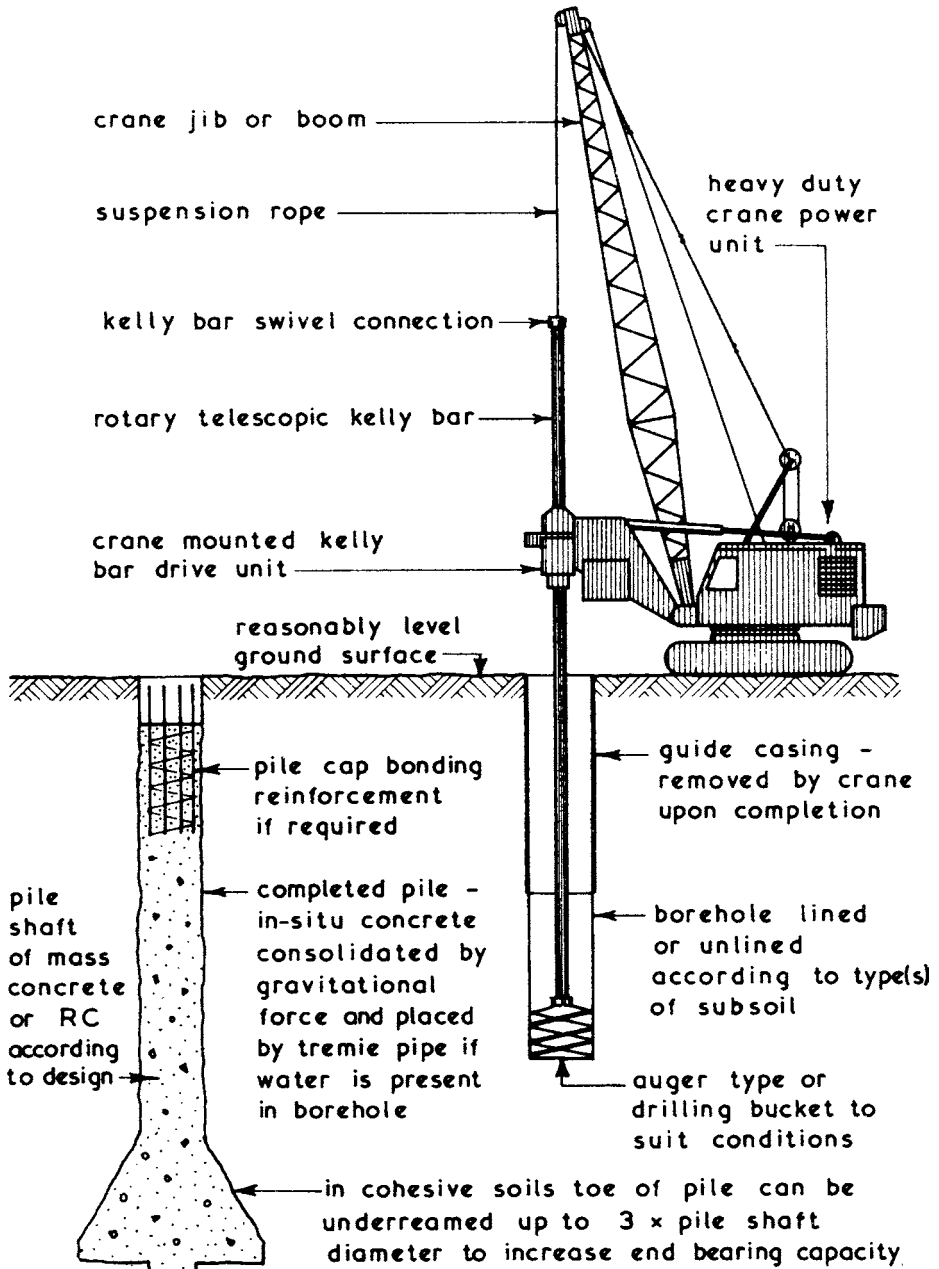

# Piled Foundations

## Continuous Flight Auger Bored Piles

Typical Details ~

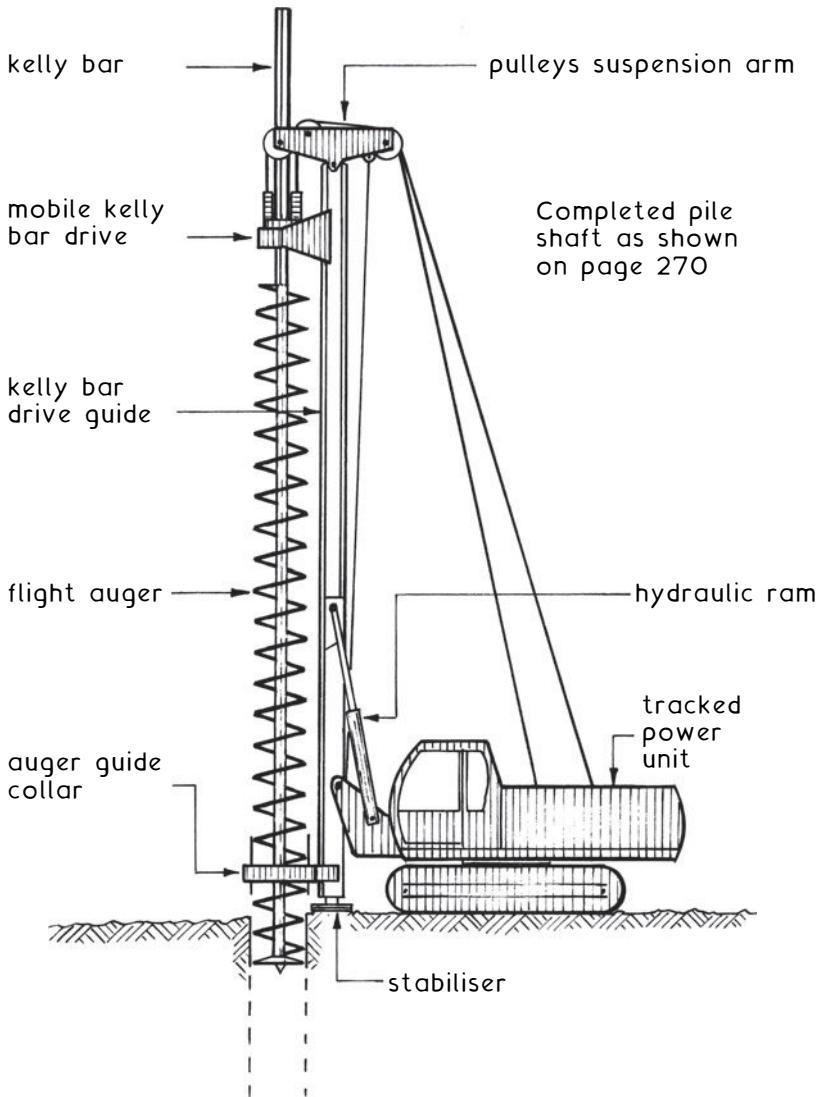

Standard pile diameters are 300, 450 and 600 mm. Depth of borehole to about 15 m.

Grout Injection Piling ~

A variation of continuous flight auger bored piling that uses an open ended hollow core to the flight. After boring to the required depth, high slump concrete is pumped through the hollow stem as the auger is retracted. Spoil is displaced at the surface and removed manually. In most applications there is no need to line the boreholes, as the subsoil has little time to be disturbed. A preformed reinforcement cage is pushed into the wet concrete.

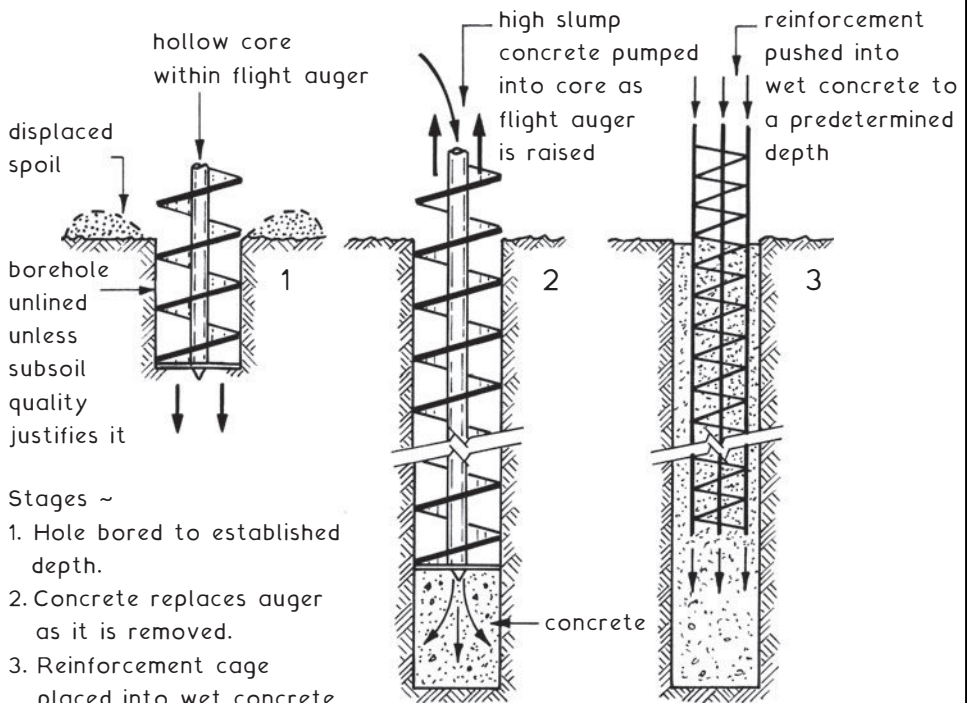

Stages ~

1. Hole bored to established depth.
2. Concrete replaces auger as it is removed.
3. Reinforcement cage placed into wet concrete.

Displacement Piles ~ these are often called driven piles since they are usually driven into the ground, displacing the earth around the pile shaft. These piles can be either preformed or partially preformed if they are not cast in-situ and are available in a wide variety of types and materials. The pile or forming tube is driven into the required position to a predetermined depth or to the required 'set' which is a measure of the subsoil's resistance to the penetration of the pile and hence its bearing capacity by noting the amount of penetration obtained by a fixed number of hammer blows.

## Displacement Pile Types ~

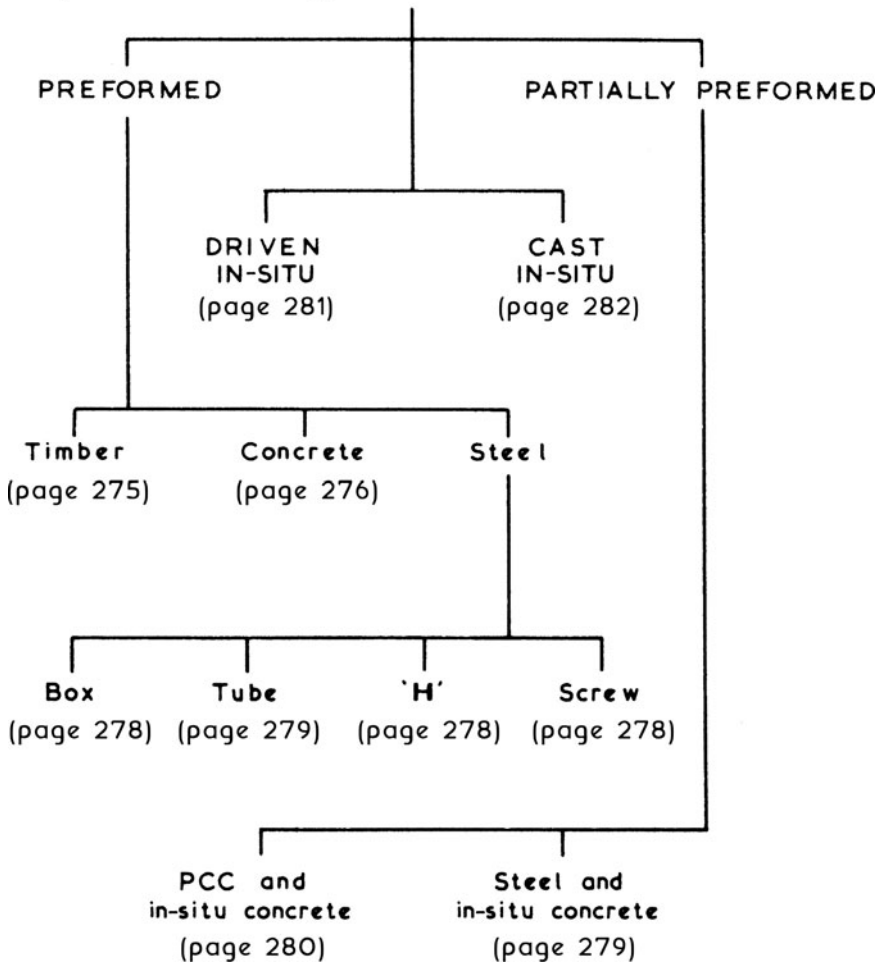

Timber Piles ~ these are usually square sawn and can be used for small contracts on sites with shallow alluvial deposits overlaying a suitable bearing strata (e.g. river banks and estuaries). Timber piles are percussion driven.

Typical Example ~

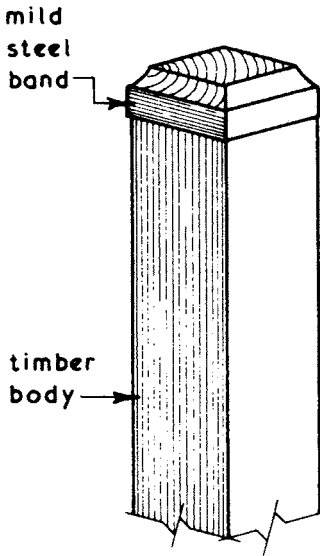

Typical Data:

load range - 50 to 350kN  
 length range - up to 12·000  
 without splicing

size range - 225 x 225  
 300 x 300 \*  
 350 x 350 \*  
 400 x 400 \*  
 450 x 450  
 600 x 600

\* common sizes

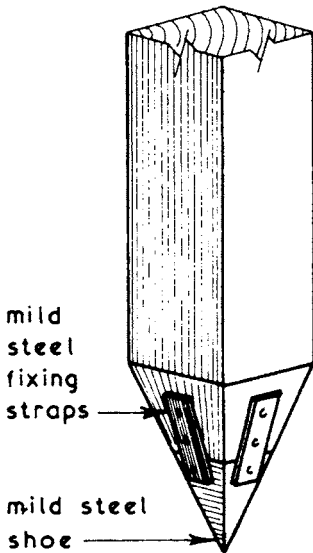

NB. timber piles are not easy to splice and are liable to attack by marine borers when set in waters; therefore such piles should always be treated with a suitable preservative before being driven.



# Piled Foundations

Preformed Concrete Piles ~ variety of types available which are generally used on medium to large contracts of not less than one hundred piles where soft soil deposits overlie a firmer strata. These piles are percussion driven using a drop or single-acting hammer.

Typical Example [West's Hardrive Precast Modular Pile] ~

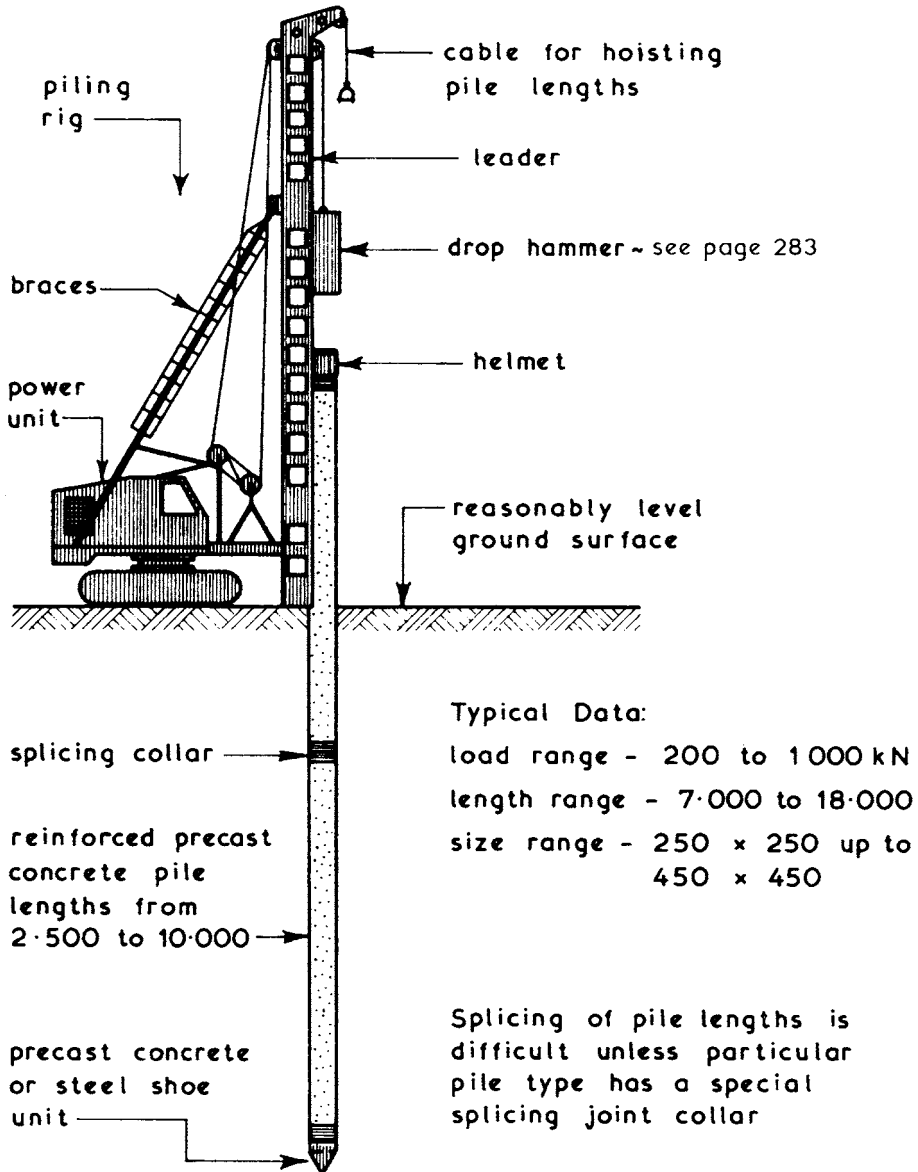

Preformed Concrete Piles – jointing with a peripheral steel splicing collar as shown on the preceding page is adequate for most concentrically or directly loaded situations. Where very long piles are to be used and/or high stresses due to compression, tension and bending from the superstructure or the ground conditions are anticipated, the four or eight lock pile joint [AARSLEFF PILING] may be considered.

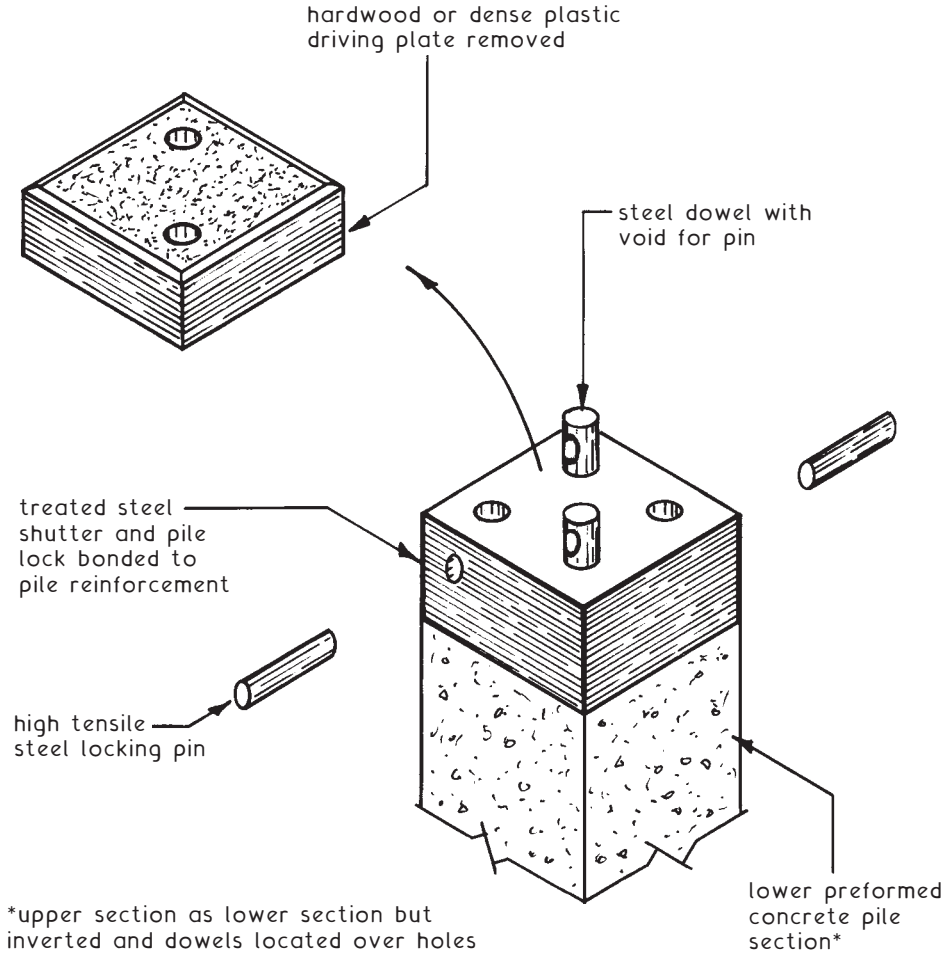

Pile dimensions (mm)	Possible no. of locks per joint
250 × 250, 300 × 300, 350 × 350 and 400 × 400	4
350 × 350, 400 × 400 and 450 × 450	8

## Piled Foundations

Steel Box and 'H' Sections ~ standard steel sheet pile sections can be used to form box section piles whereas the 'H' section piles are cut from standard rolled sections. These piles are percussion driven and are used mainly in connection with marine structures.

Typical Examples ~

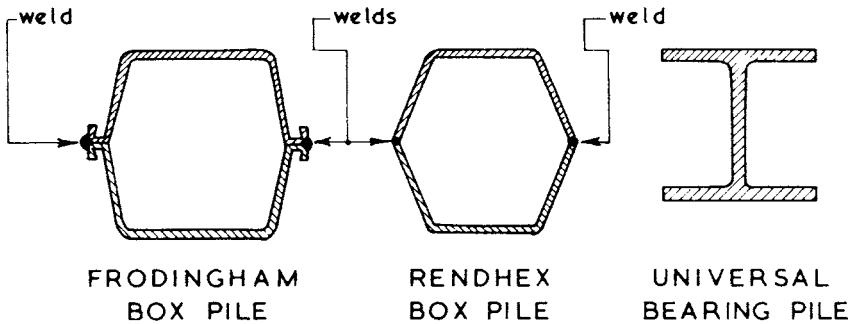

Typical Data:

load range - box piles 300 to 1500 kN  
bearing piles 300 to 1700 kN

length range - all types up to 36·000

size range - various sizes and profiles available

Steel Screw Piles ~ rotary driven and used for dock and jetty works where support at shallow depths in soft silts and sands is required.

Typical Example ~

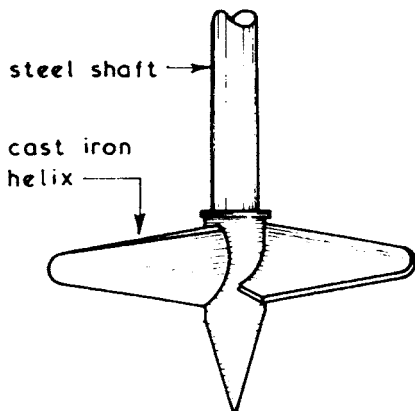

Typical Data:

load range - 400 to 3000 kN

length range - up to 24·000

size range - shafts 150 to  
350mm dia.  
overall blades  
600 to 1200

Steel Tube Piles ~ used on small to medium-size contracts for marine structures and foundations in soft subsoils over a suitable bearing strata. Tube piles are usually bottom driven with an internal drop hammer. The loading can be carried by the tube alone but it is usual to fill the tube with mass concrete to form a composite pile. Reinforcement, except for pile cap bonding bars, is not normally required.

Typical Example [BSP Cased Pile] ~

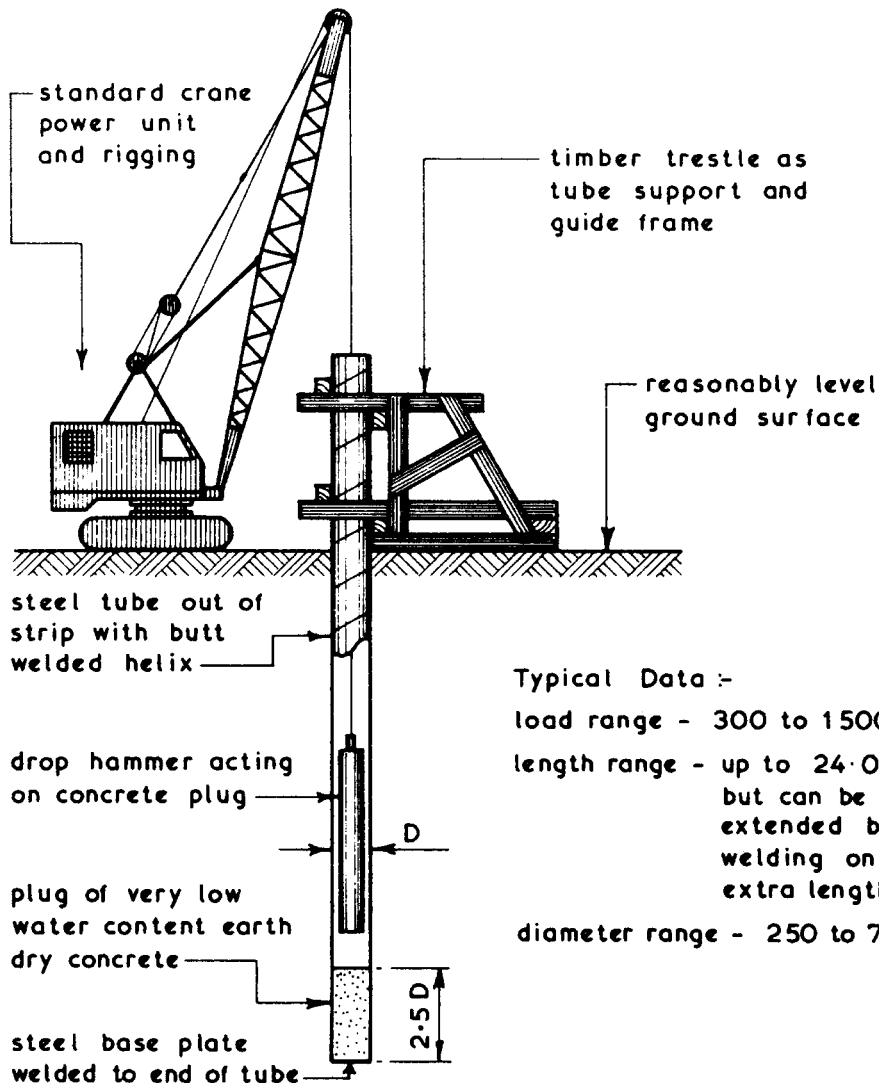

# Piled Foundations

Partially Preformed Piles ~ these are composite piles of precast concrete and in-situ concrete or steel and in-situ concrete (see page 279). These percussion-driven piles are used on medium to large contracts where bored piles would not be suitable owing to running water or very loose soils.

## Typical Example [ West's Shell Pile ] ~

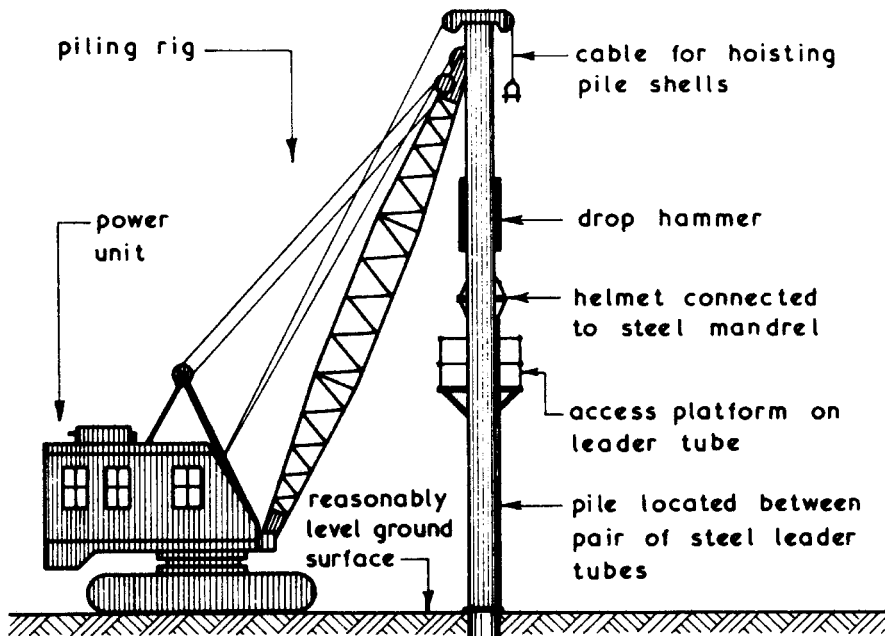

## Typical Pile Details ~

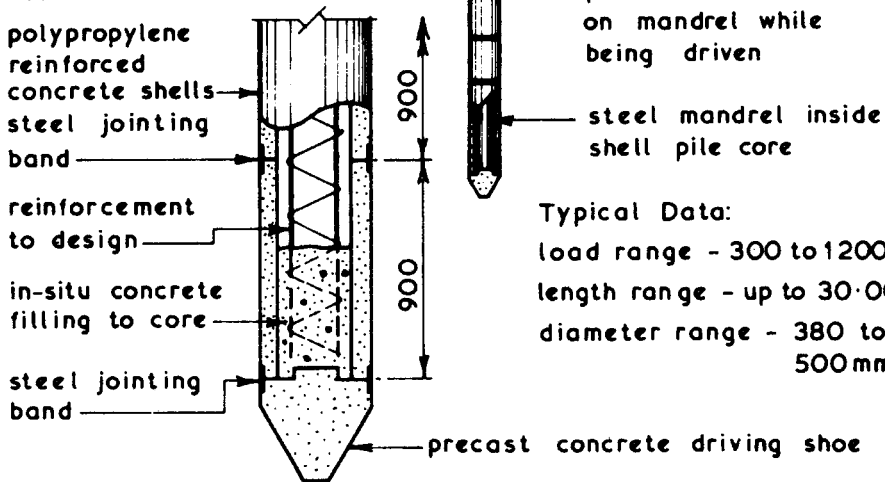

Typical Data:  
 load range - 300 to 1200kN  
 length range - up to 30.000  
 diameter range - 380 to 500mm

Driven In-situ Piles ~ used on medium to large contracts as an alternative to preformed piles particularly where final length of pile is a variable to be determined on site.

Typical Example [ Franki Driven In-situ Pile ] ~

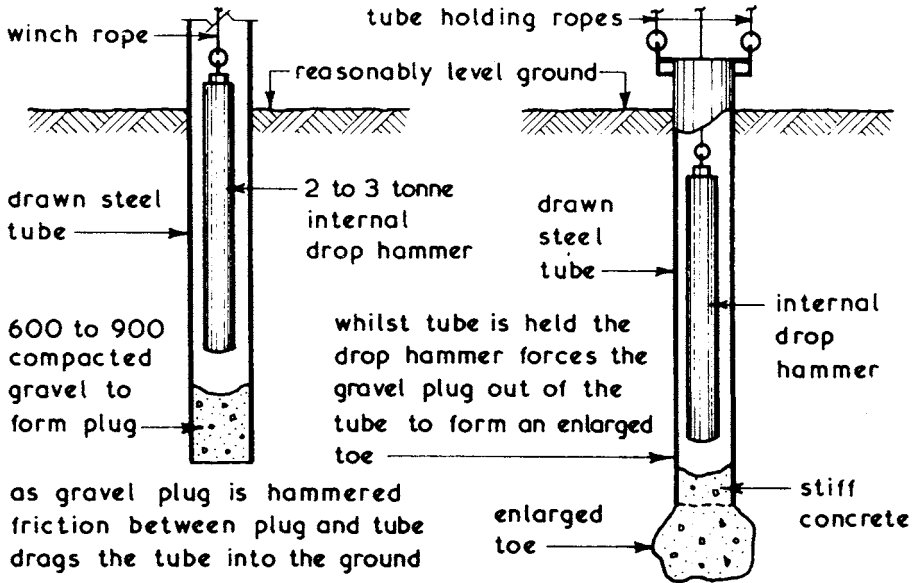

1. DRIVING TUBE

2. FORMING ENLARGED TOE

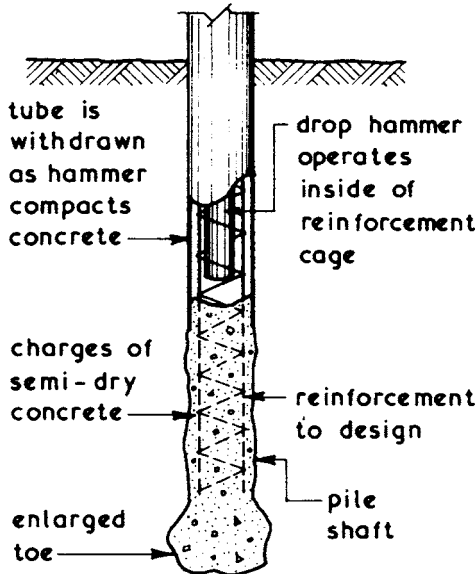

3. FORMING PILE SHAFT

The drawn steel tube is supported in the leaders of a piling rig or frame during the formation of the pile

Typical Data:

- load range - 300 to 1300 kN
- length range - up to 18.000
- diameter range - 300 to 600 mm

# Piled Foundations

Cast In-situ Piles ~ an alternative to the driven in-situ piles (see page 281)

Typical Example [ Vibro Cast In-situ Pile ] ~

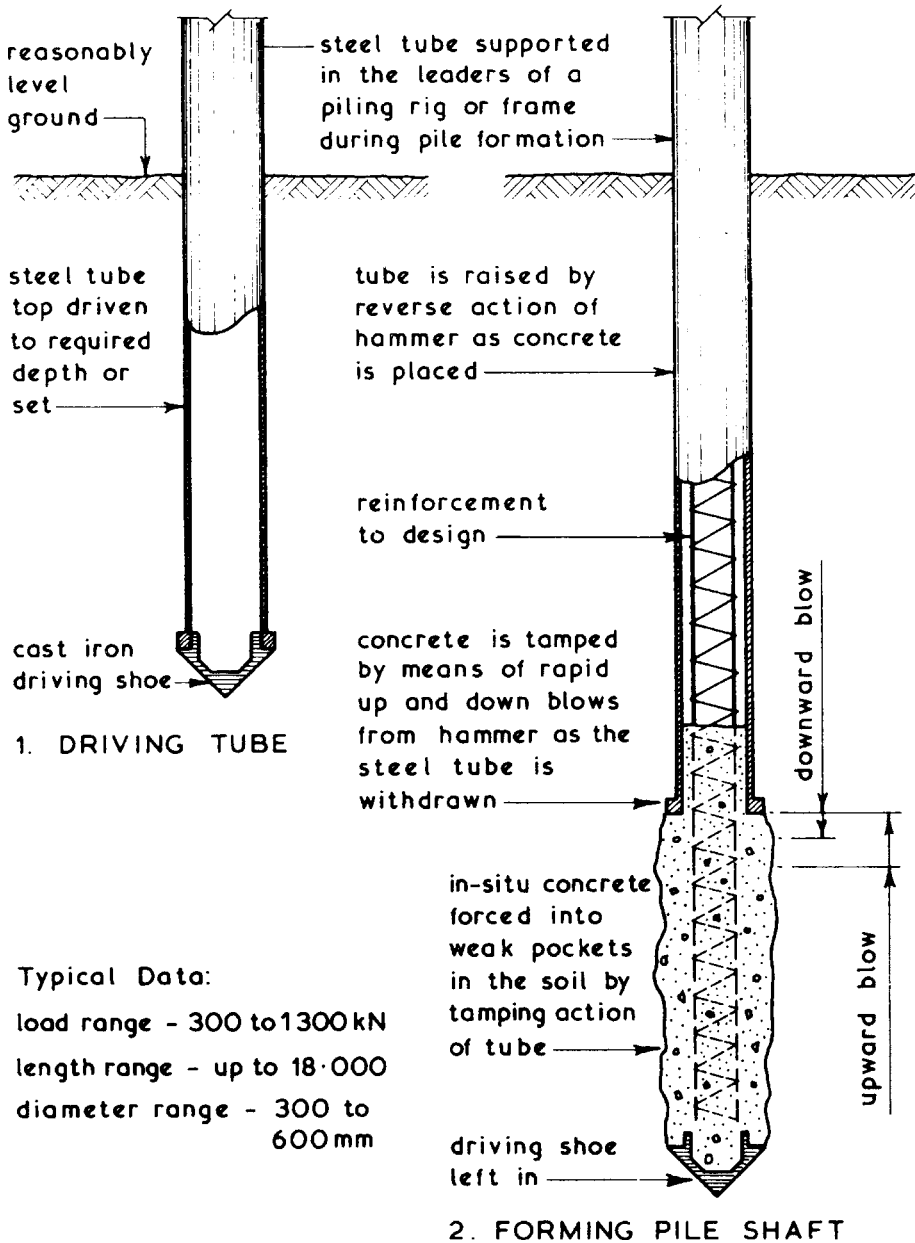

Piling Hammers ~ these are designed to deliver an impact blow to the top of the pile to be driven. The hammer weight and drop height is chosen to suit the pile type and nature of subsoil(s) through which it will be driven. The head of the pile being driven is protected against damage with a steel helmet which is padded with a sand bed or similar material and is cushioned with a plastic or hardwood block called a dolly.

Drop Hammers ~ these are blocks of iron with a rear lug(s) which locate in the piling rig guides or leaders and have a top eye for attachment of the winch rope. The number of blows which can be delivered with a free fall of 1:200 to 1:500 ranges from 10 to 20 per minute. The weight of the hammer should be not less than 50% of the concrete or steel pile weight and 1 to 1.5 times the weight of a timber pile.

Single Acting Hammers ~ these consist of a heavy falling cylinder raised by steam or compressed air sliding up and down a fixed piston. Guide lugs or rollers are located in the piling frame leaders to maintain the hammer position relative to the pile head. The number of blows delivered ranges from 36 to 75 per minute with a total hammer weight range of 2 to 15 tonnes.

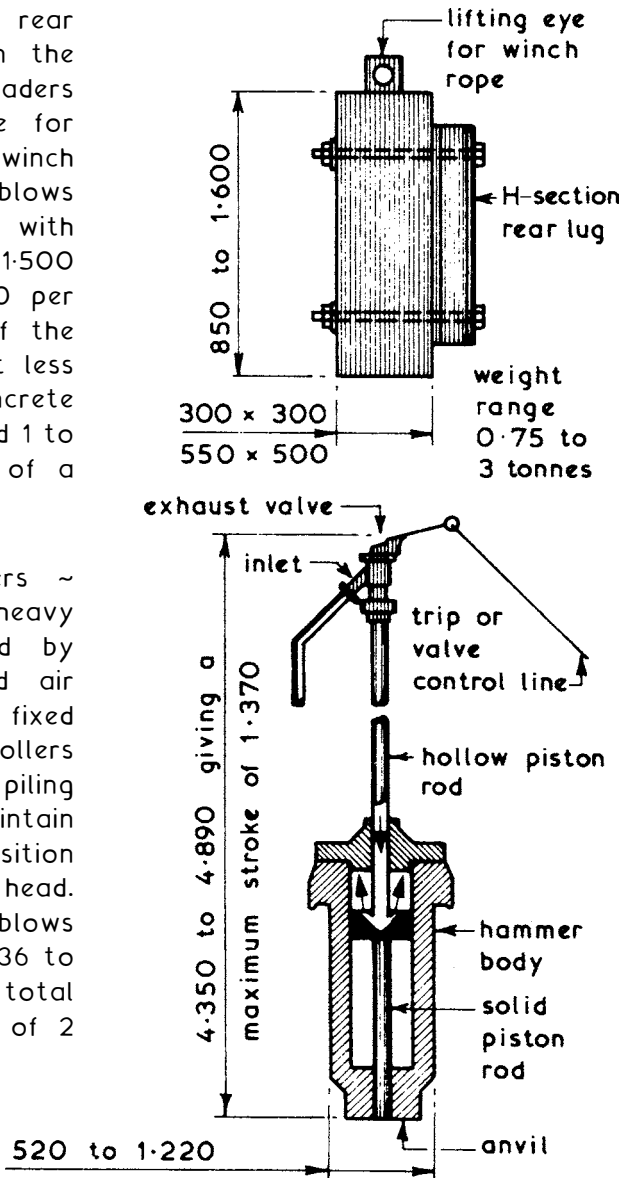



# Piled Foundations

Double Acting Hammers ~ these consist of a cast iron cylinder which remains stationary on the pile head whilst a ram powered by steam or compressed air for both up and down strokes delivers a series of rapid blows which tends to keep the pile on the move during driving. The blow delivered is a smaller force than that from a drop or single acting hammer. The number of blows delivered ranges from 95 to 300 per minute with a total hammer weight range of 0.7 to 6.5 tonnes. Diesel powered double acting hammers are also available.

Diesel Hammers ~ these are self-contained hammers which are located in the leaders of a piling rig and rest on the head of the pile. The driving action is started by raising the ram within the cylinder which activates the injection of a measured amount of fuel. The free-falling ram compresses the fuel above the anvil causing the fuel to explode and expand resulting in a downward force on the anvil and upward force which raises the ram to recommence the cycle which is repeated until the fuel is cut off. The number of blows delivered ranges from 40 to 60 per minute with a total hammer weight range of 1.0 to 4.5 tonnes.

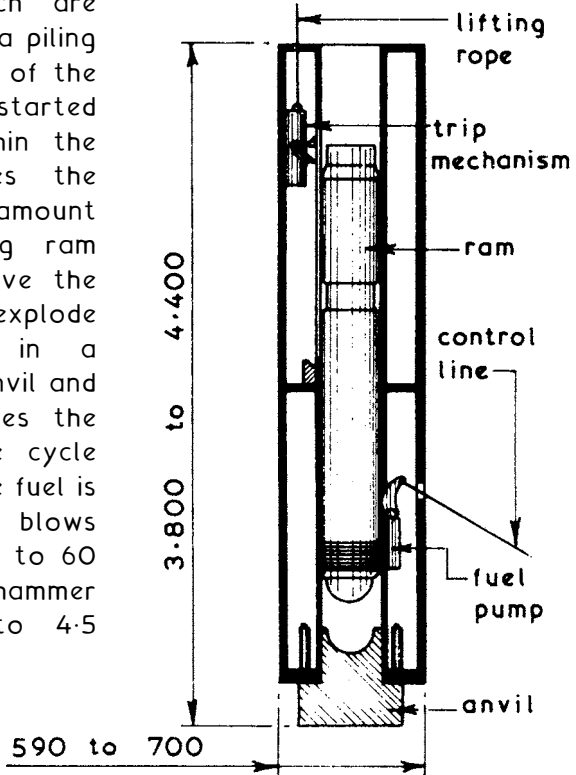
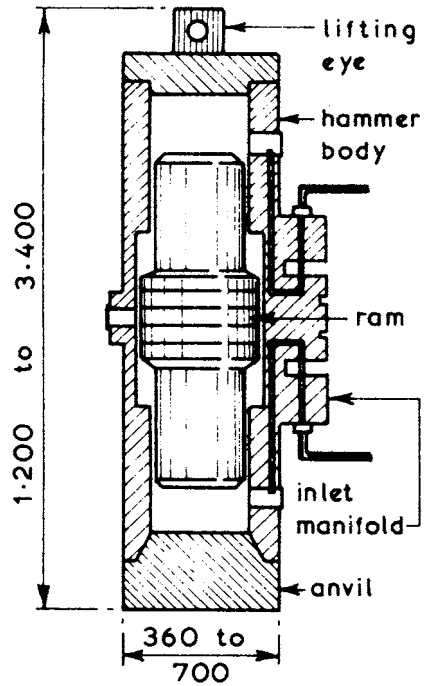

Vibrating Hammer ~ used with preformed displacement piles driven into clay, sand or gravel subsoils.

Application ~ unit suspended by cable from a crane, positioned and secured to the top of the pile. Steel pipe, H section and sheet pile profiles are most suited to this procedure.

Function ~ two electric motors are used to propel eccentric rotors in opposing directions. The vibrations generated combine with the weight of the unit to transmit through the pile. This breaks down the subsoils resistance to shear and enables the pile to penetrate. Resistance can be reduced by water jetting at the toe of the pile.

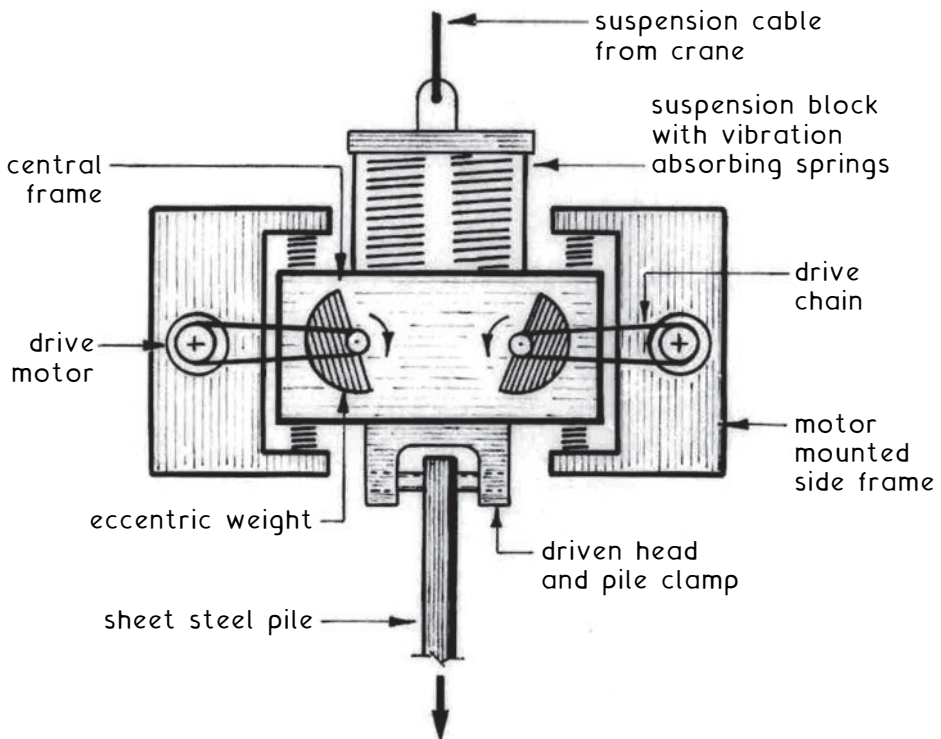

Advantages ~ relatively silent in operation, a considerable benefit in built-up areas. Use of electricity is non-polluting in the immediate site area. No impact, therefore pile cap is unlikely to be damaged.

Disadvantage ~ electricity is not always available during preliminary ground works.

# Piled Foundations

Pile Caps ~ piles can be used singly to support the load but often it is more economical to use piles in groups or clusters linked together with a reinforced concrete cap. The pile caps can also be linked together with reinforced concrete ground beams.

The usual minimum spacing for piles is:

1. Friction Piles -  $1-100$  or not less than  $3 \times$  pile diameter, whichever is the greater.
2. Bearing Piles -  $750$  mm or not less than  $2 \times$  pile diameter, whichever is the greater.

Typical Examples ~

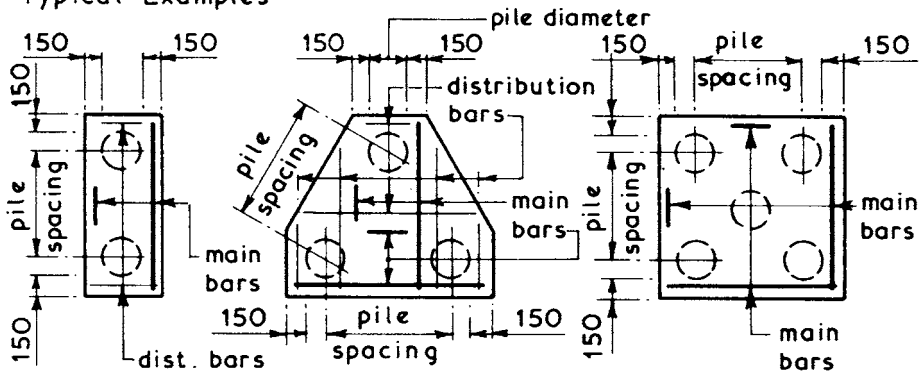

TWO PILE CAP

THREE PILE CAP

FIVE PILE CAP

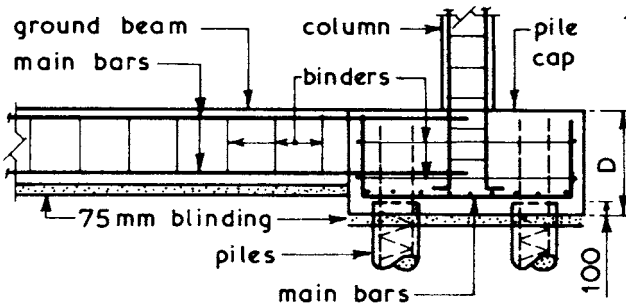

ELEVATION OF PILE CAP AND BEAM

Typical Pile Cap Depths

pile size	depth (D)
300	700
350	800
400	900
450	1000
500	1100
550	1200
600	1400

Pile Testing ~ it is advisable to test load at least one pile per scheme. The test pile should be overloaded by at least 50% of its working load and this load should be held for 24 hours. The test pile should not form part of the actual foundations. Suitable testing methods are:

1. Jacking against kentledge placed over test pile.
2. Jacking against a beam fixed to anchor piles driven in on two sides of the test pile.

Retaining Walls ~ the major function of any retaining wall is to act as an earth-retaining structure for the whole or part of its height on one face, the other being exposed to the elements. Most small height retaining walls are built entirely of brickwork or a combination of brick facing and blockwork or mass concrete backing. To reduce hydrostatic pressure on the wall from ground water an adequate drainage system in the form of weep holes should be used. Alternatively subsoil drainage behind the wall could be employed.

Typical Example of Combination Retaining Wall ~

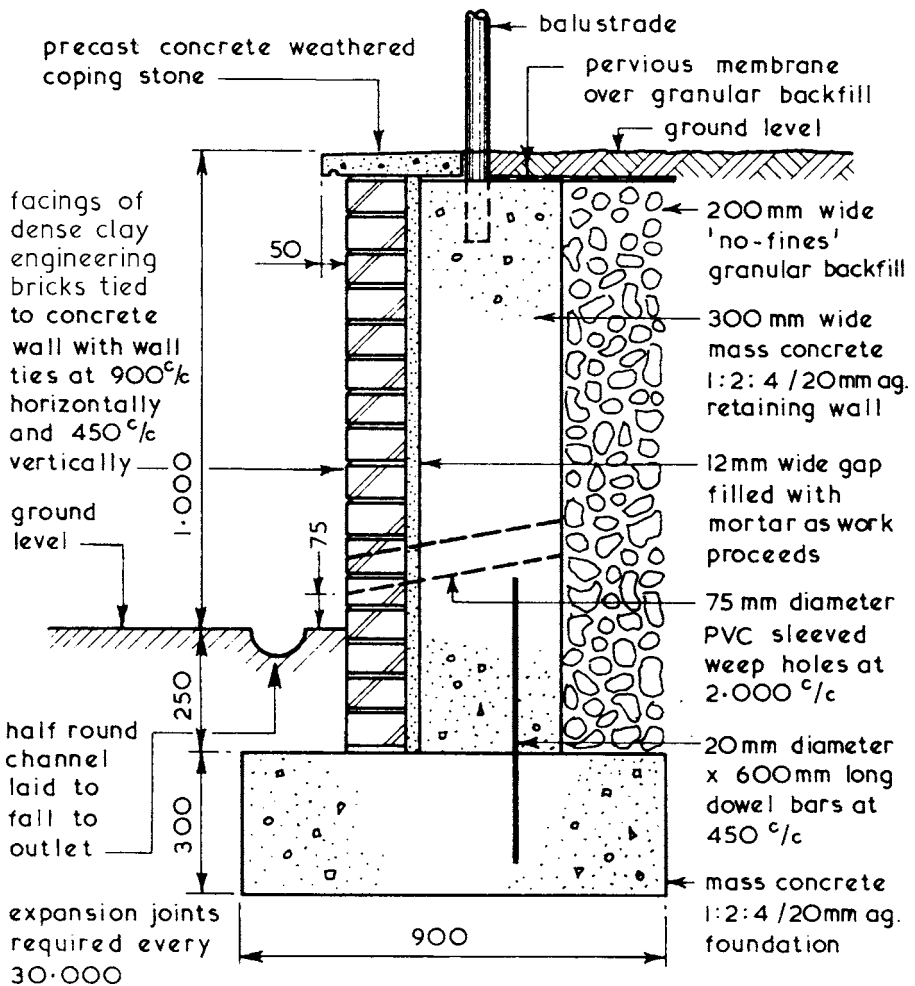

## Retaining Walls up to 1 m High (2)

Small Height Retaining Walls ~ retaining walls must be stable and the usual rule of thumb for small height brick retaining walls is for the height to lie between two and four times the wall thickness. Stability can be checked by applying the middle third rule -

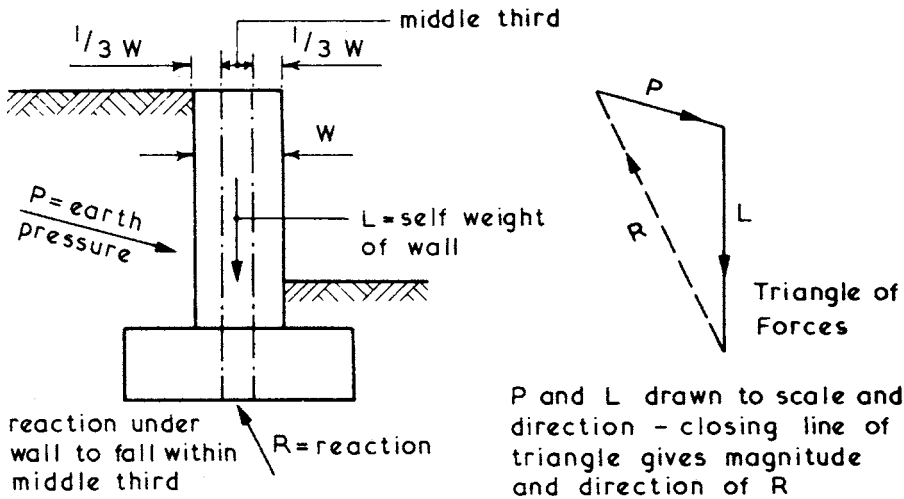

Typical Example of Brick Retaining Wall ~

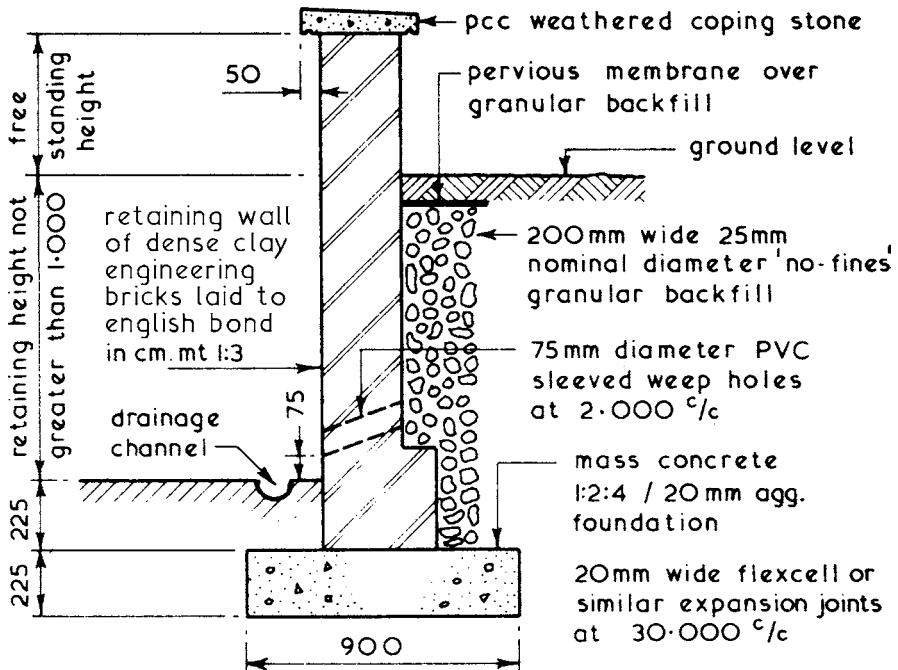

## Medium Height Retaining Walls

Retaining Walls up to 6.000 high ~ these can be classified as medium height retaining walls and have the primary function of retaining soils at an angle in excess of the soil's natural angle of repose. Walls within this height range are designed to provide the necessary resistance by either their own mass or by the principles of leverage.

Design ~ the actual design calculations are usually carried out by a structural engineer who endeavours to ensure that:

1. Overturning of the wall does not occur.
2. Forward sliding of the wall does not occur.
3. Materials used are suitable and not overstressed.
4. The subsoil is not overloaded.
5. In clay subsoils slip circle failure does not occur.

The factors which the designer will have to take into account:

1. Nature and characteristics of the subsoil(s).
2. Height of water table - the presence of water can create hydrostatic pressure on the rear face of the wall, it can also affect the bearing capacity of the subsoil together with its shear strength, reduce the frictional resistance between the underside of the foundation and the subsoil and reduce the passive pressure in front of the toe of the wall.
3. Type of wall.
4. Material(s) to be used in the construction of the wall.

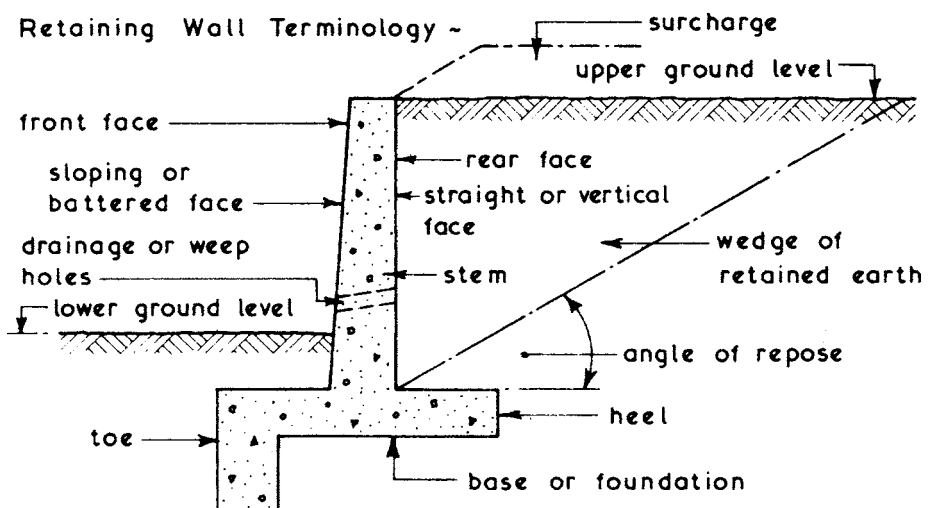

# Medium Height Retaining Walls

Earth Pressures ~ these can take one of two forms, namely:

1. Active Earth Pressures - these are those pressures which tend to move the wall at all times and consist of the wedge of earth retained plus any hydrostatic pressure. The latter can be reduced by including a subsoil drainage system behind and/or through the wall.
2. Passive Earth Pressures ~ these are a reaction of an equal and opposite force to any imposed pressure thus giving stability by resisting movement.

Typical Examples ~

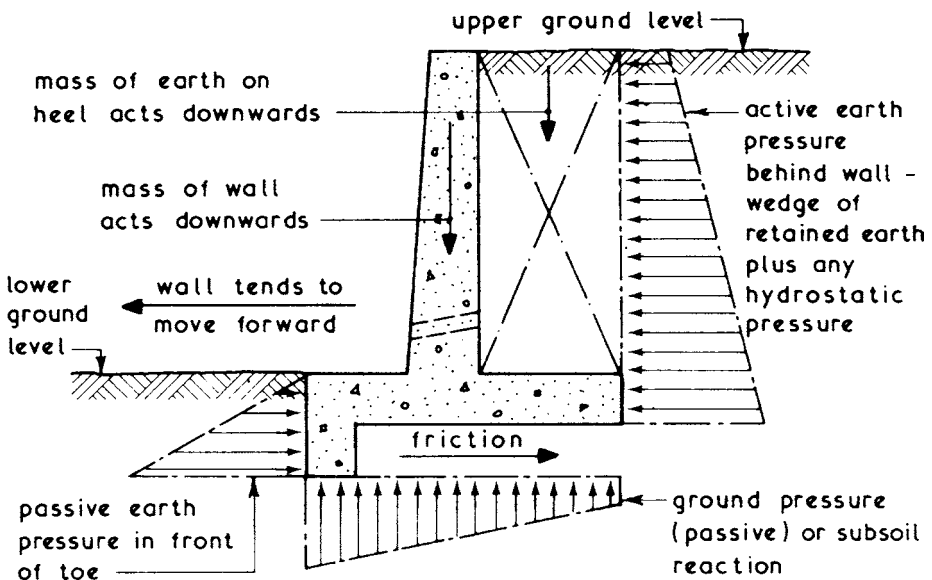
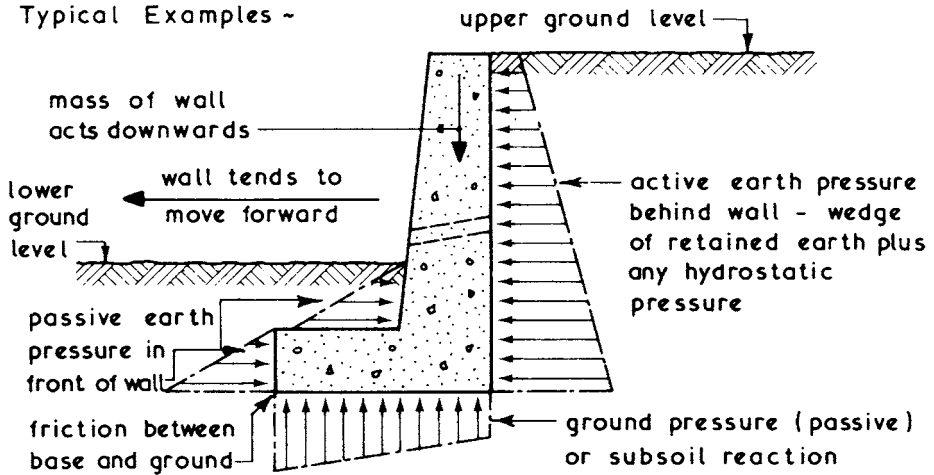

Mass Retaining Walls ~ these walls rely mainly on their own mass to overcome the tendency to slide forward. Mass retaining walls are not generally considered to be economic over a height of 1.800 when constructed of brick or concrete and 1.000 high in the case of natural stonework. Any mass retaining wall can be faced with another material but generally any applied facing will not increase the strength of the wall and is therefore only used for aesthetic reasons.

## Typical Brick Mass Retaining Wall Details ~

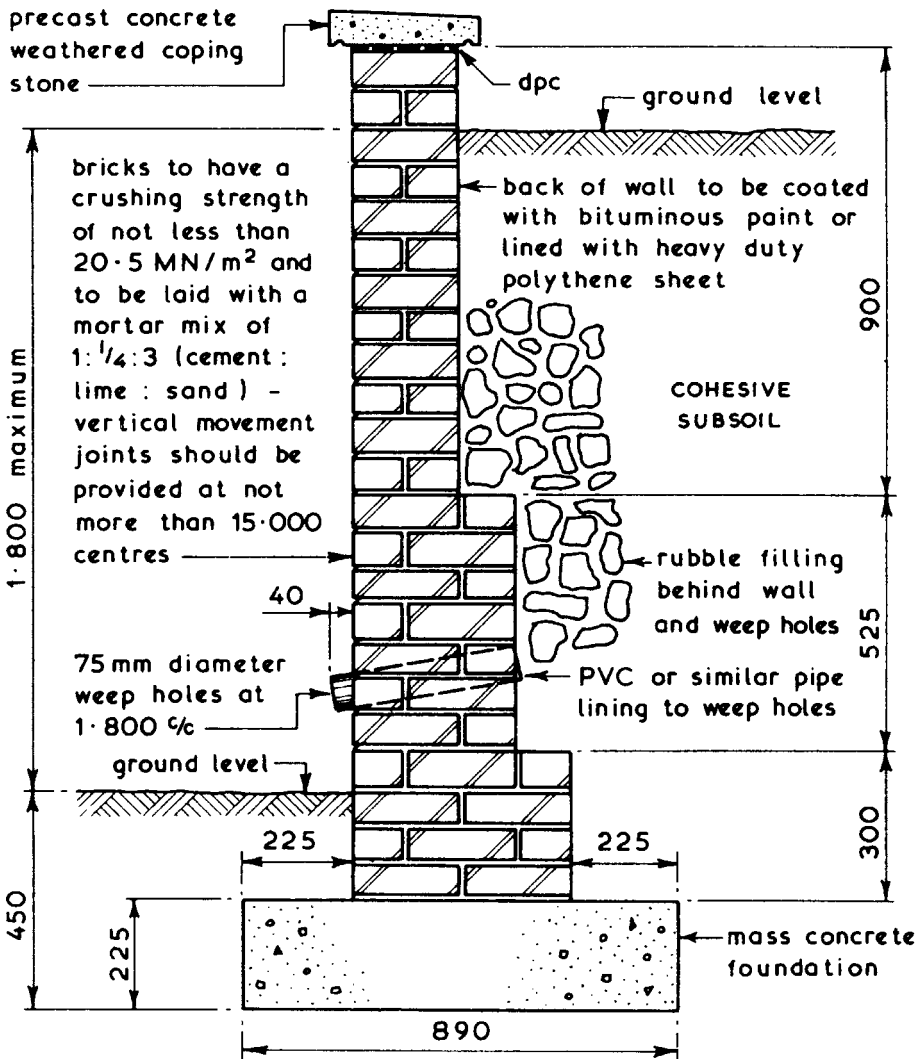



# Medium Height Retaining Walls

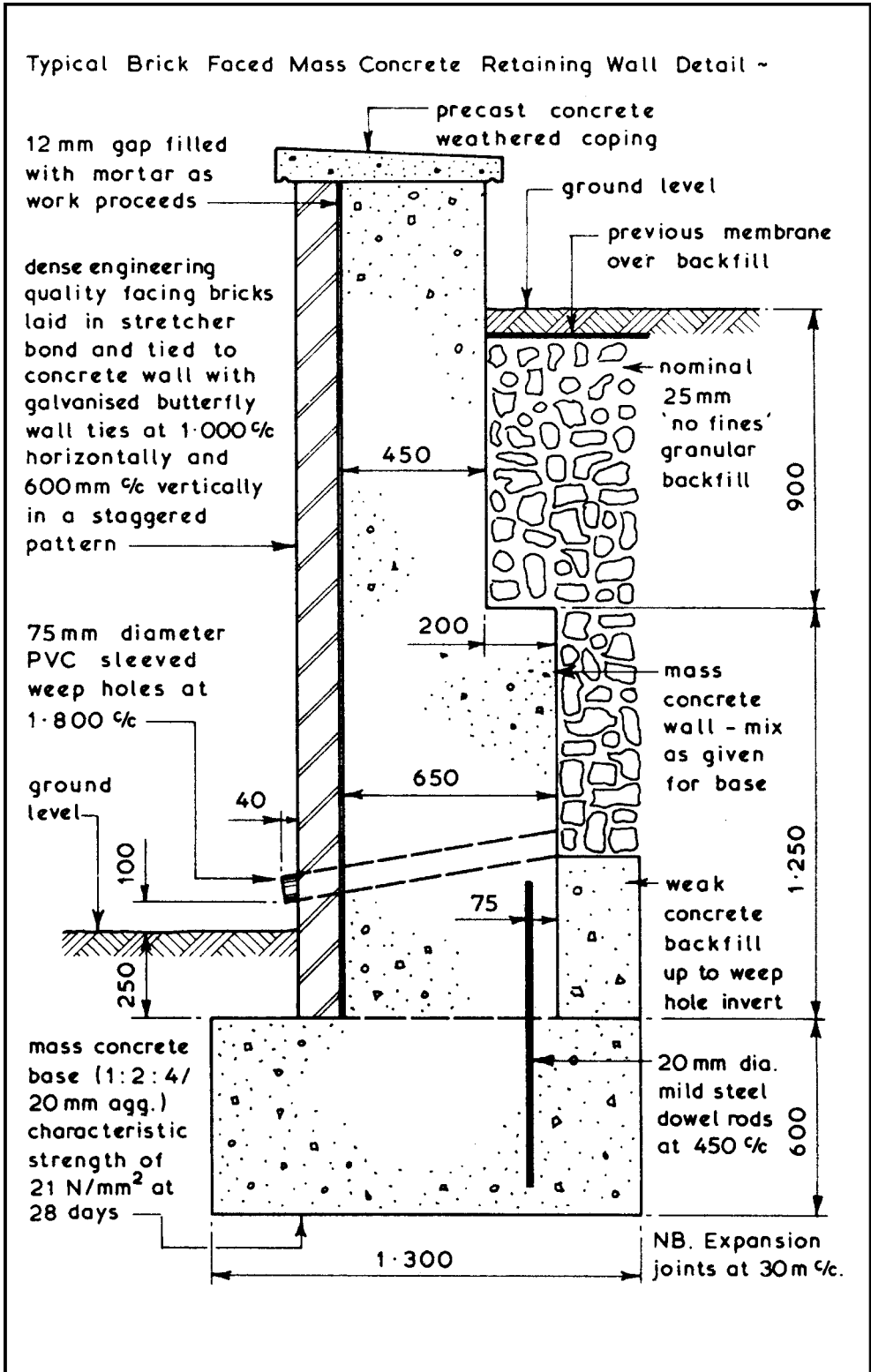

Cantilever Retaining Walls ~ these are constructed of reinforced concrete with an economic height range of 1.200 to 6.000. They work on the principles of leverage where the stem is designed as a cantilever fixed at the base and base is designed as a cantilever fixed at the stem. Several formats are possible and in most cases a beam is placed below the base to increase the total passive resistance to sliding. Facing materials can be used in a similar manner to that shown on page 292.

## Typical Formats ~

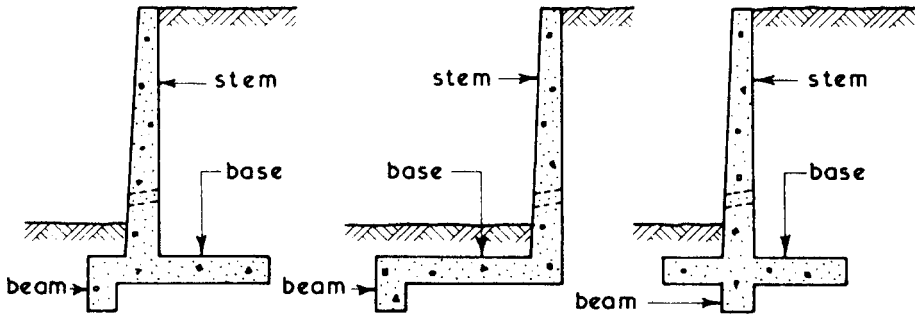

## Typical Details ~

concrete to be 1:2:4/  
20mm aggregate with  
minimum cube crushing  
strength of 21 N/mm<sup>2</sup>  
at 28 days

welded fabric to  
control shrinkage  
cracks

75 mm diameter weep  
holes at 1.800 %

300  
ground level

100

450mm wide  
beam

900

450

3.000

300

ground level

previous membrane  
over nominal 25mm  
'no fines' granular  
backfill

main bars at 300%

nominal diameter  
distribution bars

main bars at 150%

distribution bars

450

75mm blinding

welded fabric

4.200

450

## Medium Height Retaining Walls

Formwork ~ concrete retaining walls can be cast in one of three ways - full height; climbing (page 295) or against earth face (page 296).

Full Height Casting ~ this can be carried out if the wall is to be cast as a free-standing wall and allowed to cure and gain strength before the earth to be retained is backfilled behind the wall. Considerations are the height of the wall, anticipated pressure of wet concrete, any strutting requirements and the availability of suitable materials to fabricate the formwork. As with all types of formwork a traditional timber format or a patent system using steel forms could be used.

### Typical Details ~

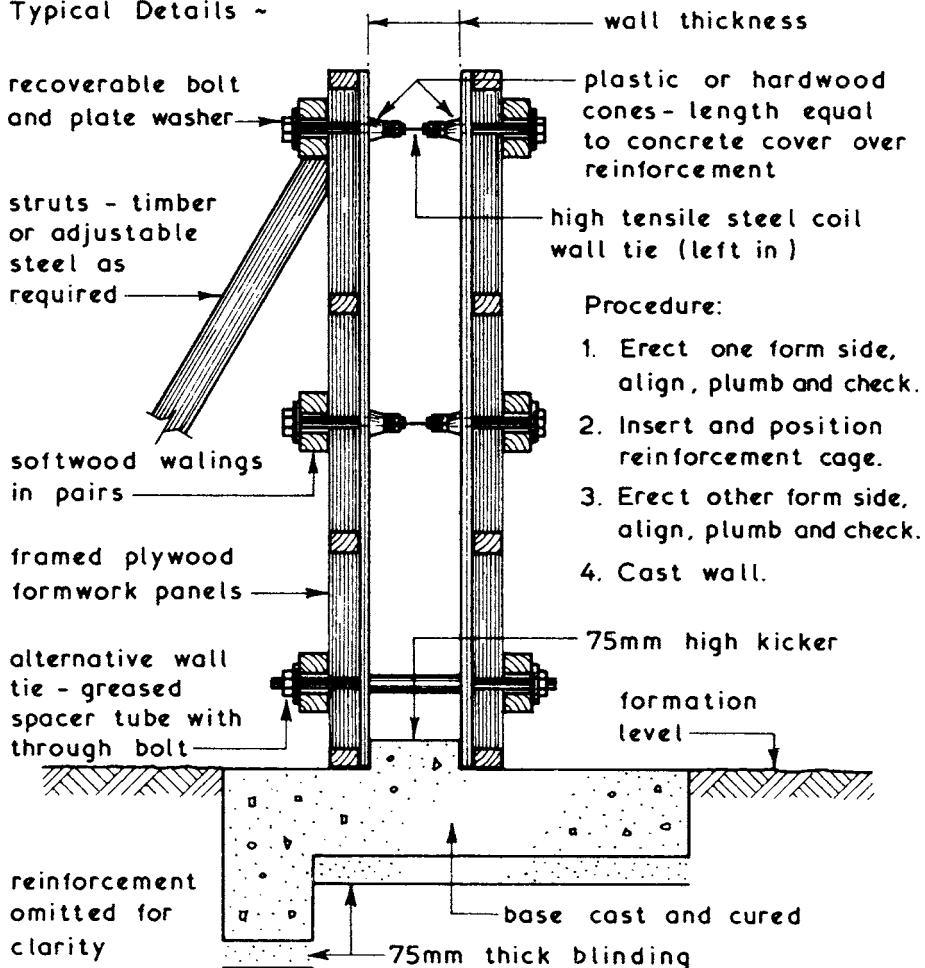

### Procedure:

1. Erect one form side, align, plumb and check.
2. Insert and position reinforcement cage.
3. Erect other form side, align, plumb and check.
4. Cast wall.

# Medium Height Retaining Walls

Climbing Formwork or Lift Casting ~ this method can be employed on long walls, high walls or where the amount of concrete which can be placed in a shift is limited.

Typical Details ~

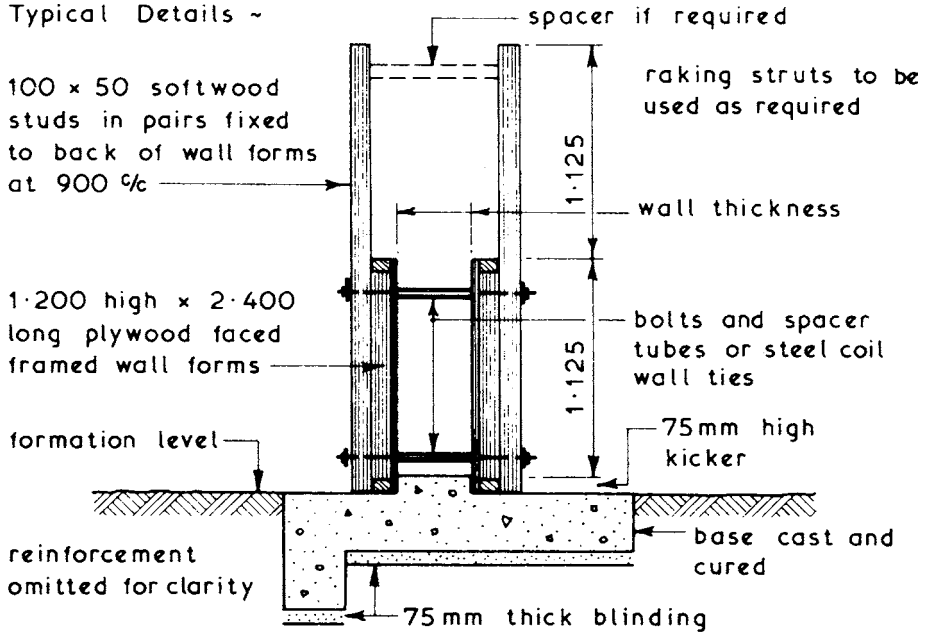

STAGE ONE OR FIRST LIFT

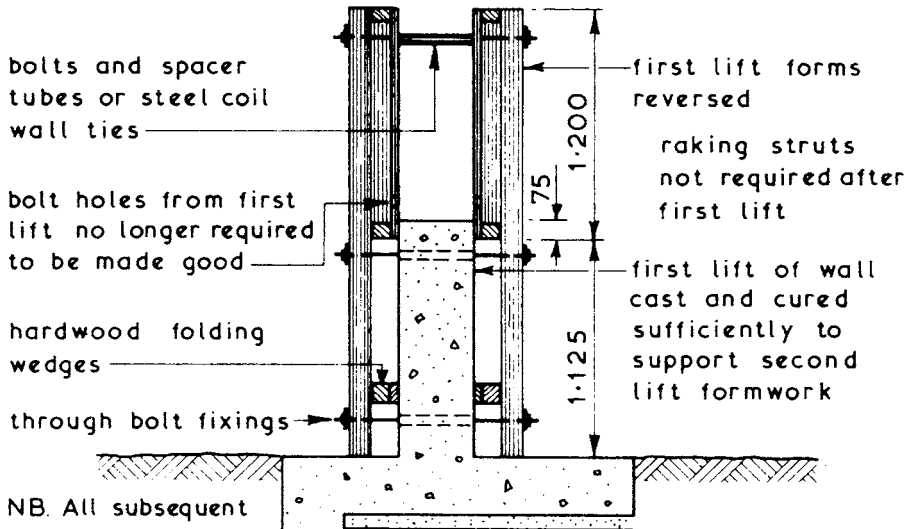

STAGE TWO OR SECOND LIFT

# Medium Height Retaining Walls

Casting Against Earth Face ~ this method can be an adaptation of the full height or climbing formwork systems. The latter uses a steel wire loop tie fixing to provide the support for the second and subsequent lifts.

## Typical Details ~

100 x 50 x 2.325 long studs in pairs fixed to back of wall forms at 900 %

recoverable bolt and washer

1.200 high x 2.400 long plywood faced framed wall forms

struts as required

sole plate fixed to base

earth face

plastic or hardwood cones

high tensile steel wire loop tie

75 mm high kicker

base cast and cured

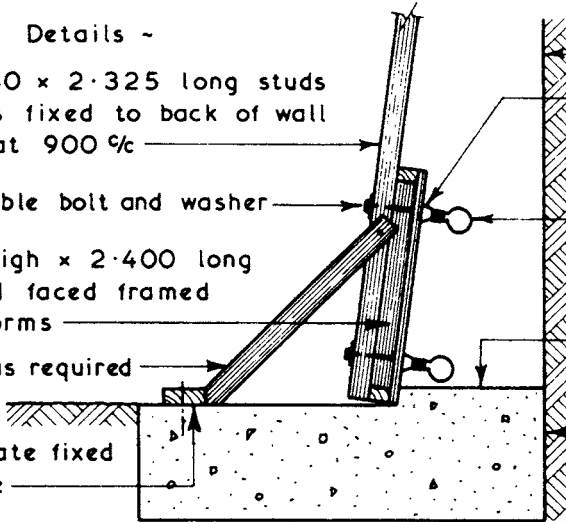

STAGE ONE OR FIRST LIFT

first lift wall form reversed

bolt holes from first lift no longer required to be made good

hardwood folding wedges

formation level

NB. All subsequent lifts as shown for second lift.

steel wire loop tie if more than two lifts required

first lift of wall cast and cured to support second lift formwork

steel wire loop ties cast in

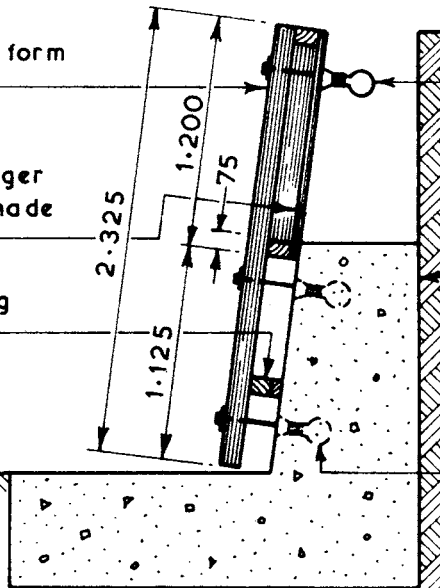

STAGE TWO OR SECOND LIFT

## Retaining Walls – Reinforced Masonry

Masonry units – these are an option where it is impractical or cost-ineffective to use temporary formwork to in-situ concrete. Exposed brick or blockwork may also be a preferred finish. In addition to being a structural component, masonry units provide permanent formwork to reinforced concrete poured into the voids created by:

- \* Quetta bonded standard brick units, OR
- \* Stretcher bonded standard hollow dense concrete blocks.

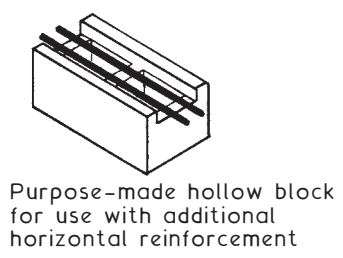
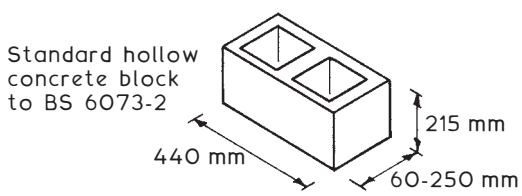
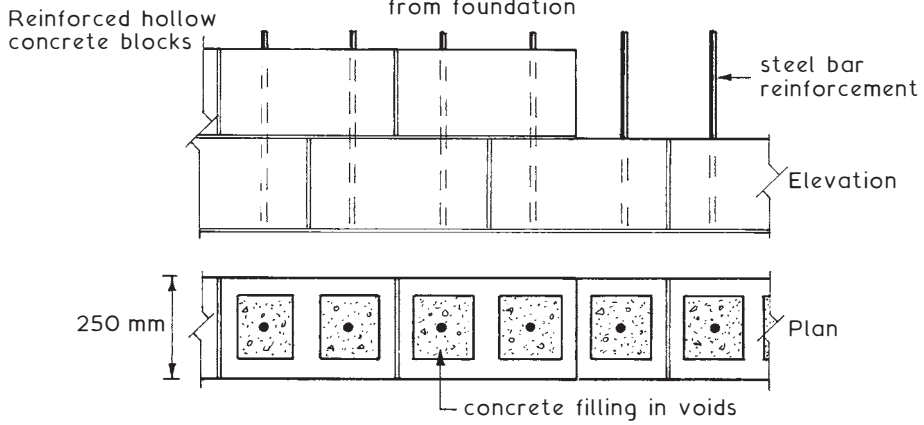
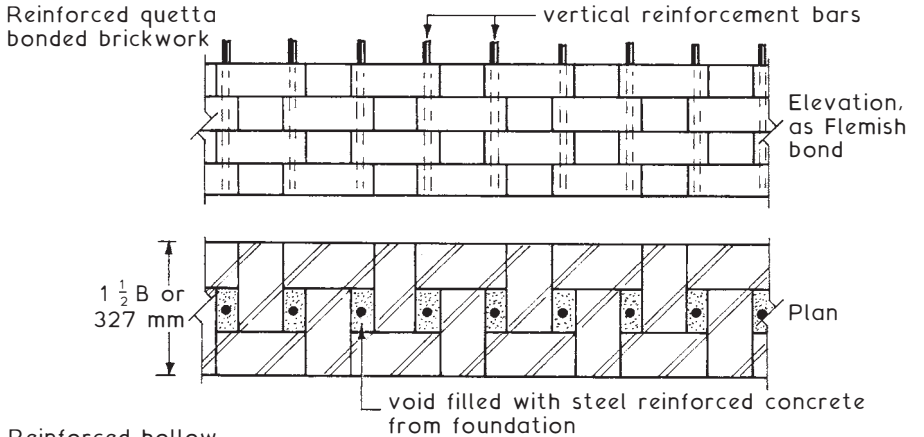

# Post-tensioned Retaining Wall

Construction - a reinforced concrete base is cast with projecting steel bars accurately located for vertical continuity. The wall may be built solid, e.g. Quetta bond, with voids left around the bars for subsequent grouting. Alternatively, the wall may be of wide cavity construction, where the exposed reinforcement is wrapped in 'denso' grease tape for protection against corrosion. Steel bars are threaded at the top to take a tensioning nut over a bearing plate.

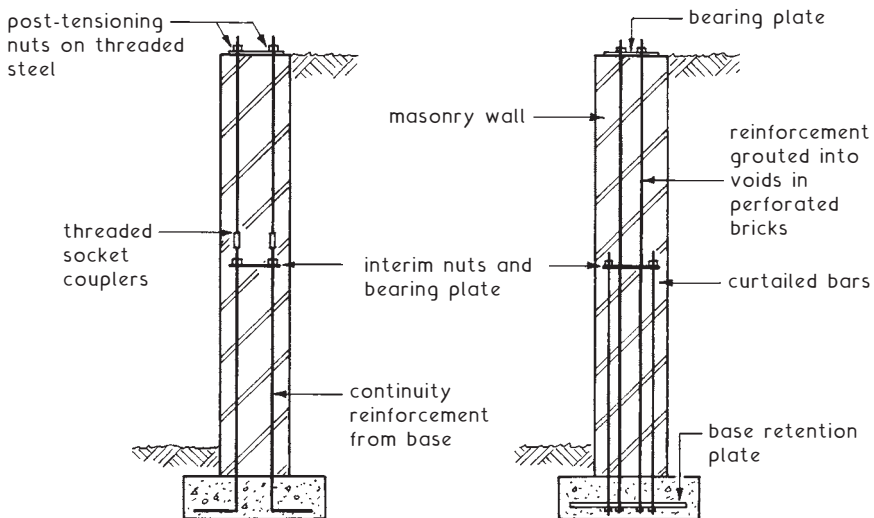
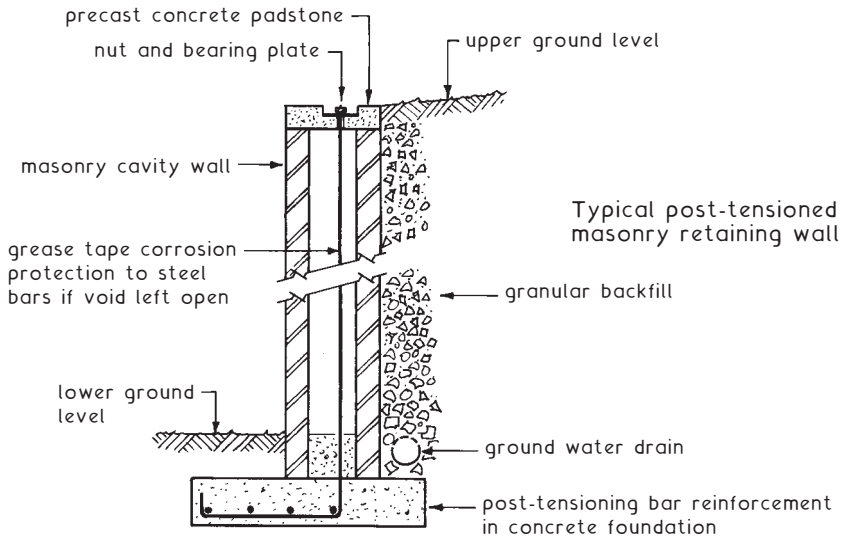

Staged post-tensioning to high masonry retaining walls

Refs. BS EN 1996-1-1: Design of masonry structures. General rules for reinforced and unreinforced masonry structures.

PD 6697: Recommendations to BS EN 1996-1-1.

Crib Retaining Walls – a system of precast concrete or treated timber components comprising headers and stretchers which interlock to form a three-dimensional framework. During assembly the framework is filled with graded stone to create sufficient mass to withstand ground pressures.

Principle –

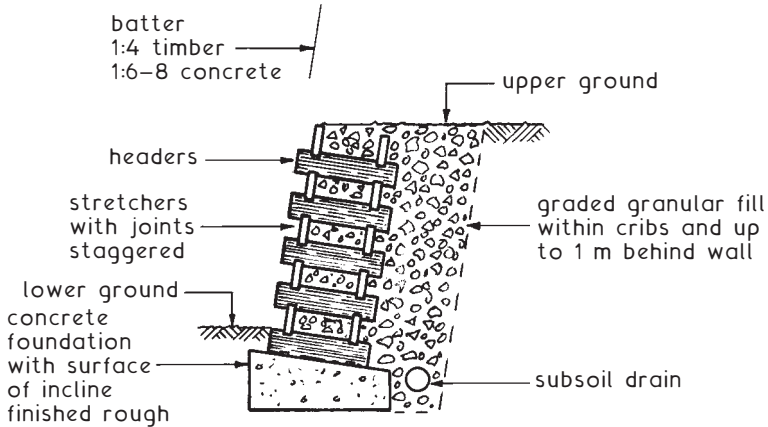

NB. height limited to 10 m with timber.

Components –

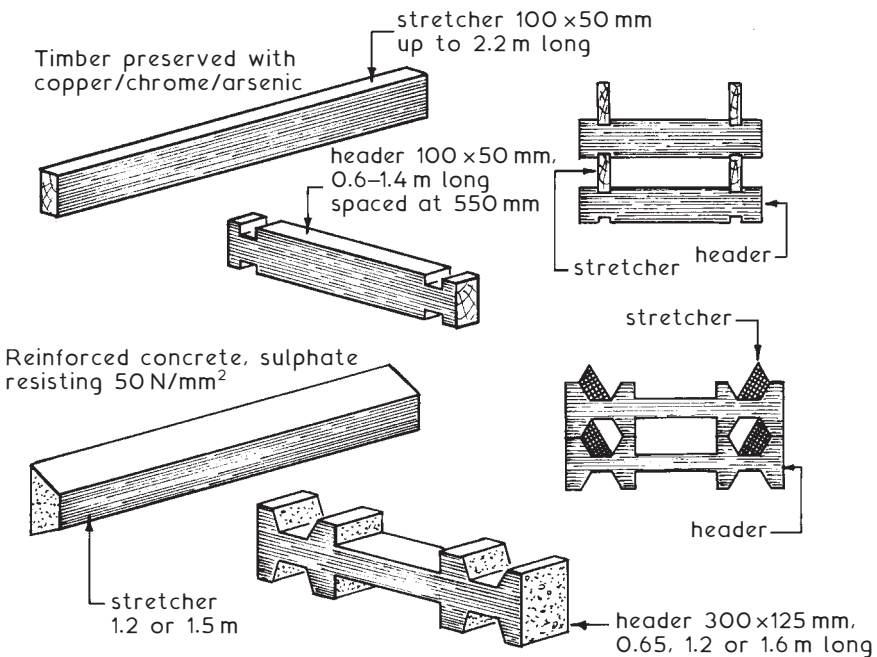



## Soil Nailing

Soil Nailing ~ a cost effective geotechnic process used for retaining large soil slopes, notably highway and railway embankments.

Function ~ after excavating and removing the natural slope support, the remaining wedge of exposed unstable soil is pinned or nailed back with tendons into stable soil behind the potential slip plane.

Types of Soil Nails or Tendons:

- Solid deformed steel rods up to 50 mm in diameter, located in boreholes up to 100 mm in diameter. Cement grout is pressurised into the void around the rods.
- Hollow steel, typically 100 mm diameter tubes with an expendable auger attached. Cement grout is injected into the tube during boring to be ejected through purpose-made holes in the auger.
- Solid glass reinforced plastic (GRP) with resin grouts.

Embankment Treatment ~ the exposed surface is faced with a plastic coated wire mesh to fit over the ends of the tendons. A steel head plate is fitted over and centrally bolted to each projecting tendon, followed by spray concreting to the whole face.

Typical Application ~

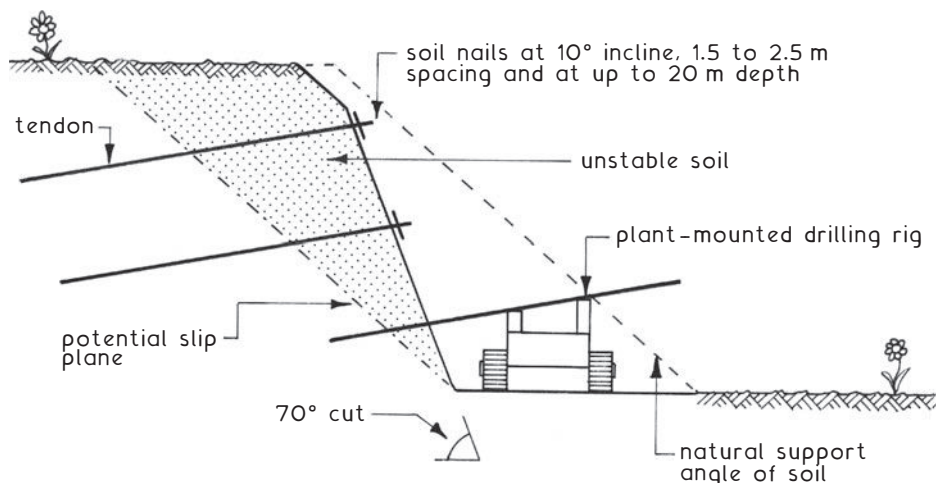

Gabion ~ a type of retaining wall produced from individual rectangular boxes made from panels of wire mesh, divided internally and filled with stones. These units are stacked and overlapped (like stretcher bonded masonry) and applied in several layers or courses to retained earth situations. Typical sizes, 1.0m long x 0.5m wide x 0.5m high, up to 4.0m long x 1.0m wide x 1.0m high.

Matress ~ unit fabrication is similar to a gabion but of less thickness, smaller mesh and stone size to provide some flexibility and shaping potential. Application is at a much lower incline. Generally used next to waterways for protection against land erosion where tidal movement and/or water level differentials could scour embankments. Typical sizes, 3.0m long x 2.0m wide x 0.15m thick, up to 6.0m long x 2.0m wide x 0.3m thick.

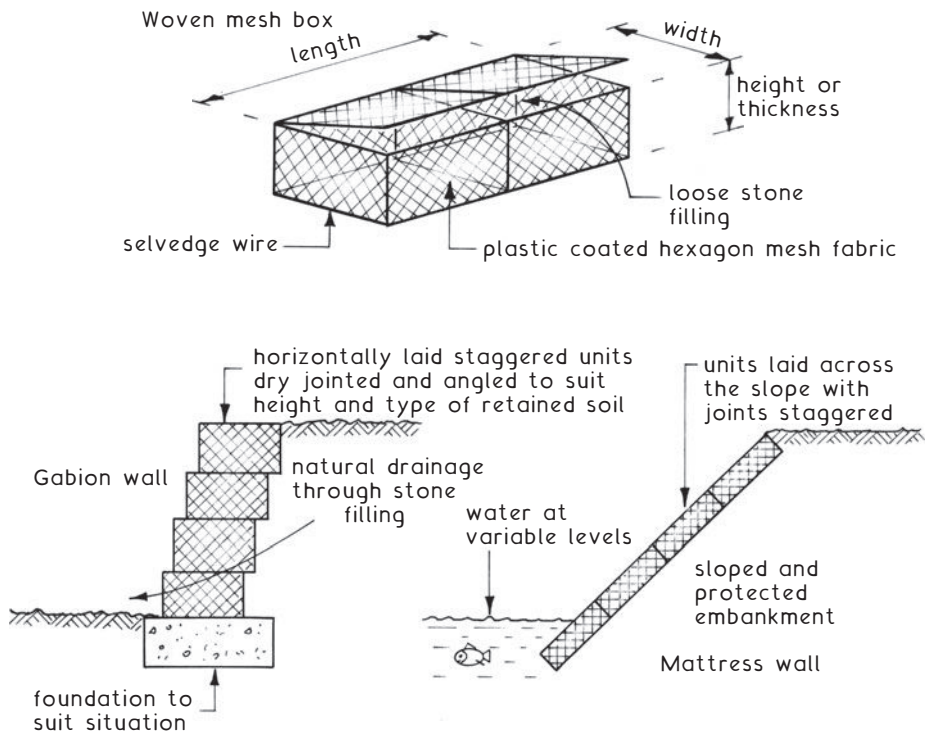

## Retaining Walls—Design Calculations

Design of Retaining Walls ~ this should allow for the effect of hydrostatics or water pressure behind the wall and the pressure created by the retained earth (see page 290). Calculations are based on a 1m unit length of wall, from which it is possible to ascertain:

1. The resultant thrust
2. The overturning or bending moment

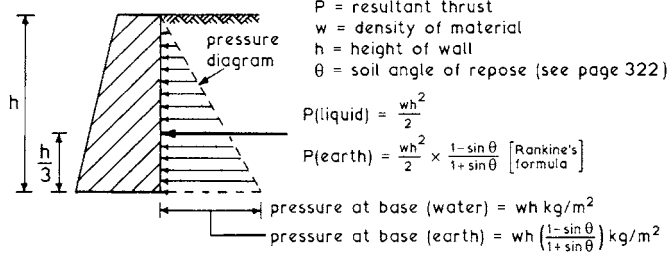

$P$ , the resultant thrust, will act through the centre of gravity of the pressure diagram, i.e. at  $h/3$ .

The overturning moment due to water is therefore:

$$\frac{wh^2}{2} \times \frac{h}{3} \text{ or } \frac{wh^3}{6}$$

and for earth:

$$\frac{wh^2}{2} \times \frac{1-\sin\theta}{1+\sin\theta} \times \frac{h}{3} \text{ or } \frac{wh^3}{6} \times \frac{1-\sin\theta}{1+\sin\theta}$$

Typical example ~

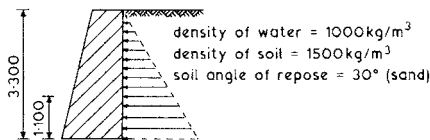

For water:

$$p = \frac{wh^2}{2} = \frac{1000 \times (3.3)^2}{2} = 5445 \text{ kg}$$

NB.  $\text{kg} \times \text{gravity} = \text{Newtons}$

Therefore,  $5445 \text{ kg} \times 9.81 = 53.42 \text{ kN}$

The overturning or bending moment will be:

$$P \times h/3 = 53.42 \text{ kN} \times 1.1 \text{ m} = 58.8 \text{ kNm}$$

For earth:

$$p = \frac{wh^2}{2} \times \frac{1-\sin\theta}{1+\sin\theta}$$

$$p = \frac{1500 \times (3.3)^2}{2} \times \frac{1-\sin 30^\circ}{1+\sin 30^\circ} = 2723 \text{ kg or } 26.7 \text{ kN}$$

The overturning or bending moment will be:

$$P \times h/3 = 26.7 \text{ kN} \times 1.1 \text{ m} = 29.4 \text{ kNm}$$

## Retaining Walls – Coulomb's Wedge Theory

A graphical design solution, to determine the earth thrust (P) behind a retaining wall. Data from previous page:

$$h = 3.300 \text{ m}$$

$$\theta = 30^\circ$$

$$w = 1500 \text{ kg/m}^3$$

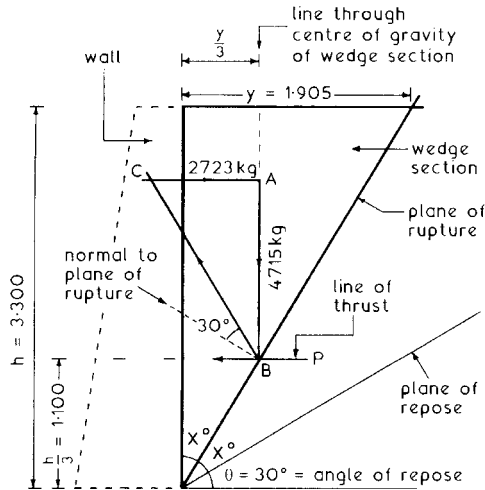

Wall height is drawn to scale and plane of repose plotted. The wedge section is obtained by drawing the plane of rupture through an angle bisecting the plane of repose and vertical back of the wall. Dimension 'y' can be scaled or calculated:

$$\text{Tangent } x = \frac{y}{3.3} \quad x = 30^\circ, \text{ and } \tan 30^\circ = 0.5774$$

$$\text{therefore, } y = 3.3 \times 0.5774 = 1.905 \text{ m}$$

$$\text{Area of wedge section} = \frac{3.3}{2} \times 1.905 \text{ m} = 3.143 \text{ m}^2$$

$$\text{Volume of wedge per metre run of wall} = 3.143 \times 1 = 3.143 \text{ m}^3$$

$$\text{Weight} \dots \dots \dots = 3.143 \times 1500 = 4715 \text{ kg}$$

Vector line A - B is drawn to a scale through centre of gravity of wedge section, line of thrust and plane of rupture to represent 4715 kg.

Vector line B - C is drawn at the angle of earth friction (usually same as angle of repose, i.e. 30° in this case), to the normal to the plane of rupture until it meets the horizontal line C - A.

Triangle ABC represents the triangle of forces for the wedge section of earth, so C - A can be scaled at 2723 kg to represent (P), the earth thrust behind the retaining wall.

## Basement Excavations

Open Excavations ~ one of the main problems which can be encountered with basement excavations is the need to provide temporary support or timbering to the sides of the excavation. This can be intrusive when the actual construction of the basement floor and walls is being carried out. One method is to use battered excavation sides cut back to a safe angle of repose thus eliminating the need for temporary support works to the sides of the excavation.

Typical Example of Open Basement Excavations ~

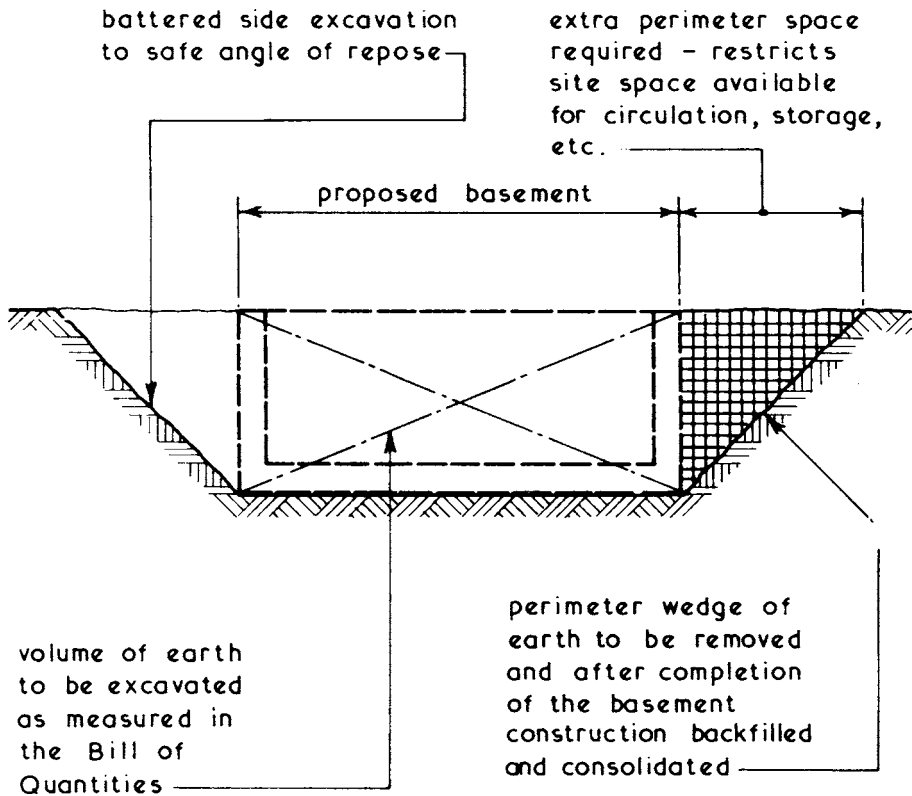

In economic terms the costs of plant and manpower to cover the extra excavation, backfilling and consolidating must be offset by the savings made by omitting the temporary support works to the sides of the excavation. The main disadvantage of this method is the large amount of free site space required.

Perimeter Trench Excavations ~ in this method a trench wide enough for the basement walls to be constructed is excavated and supported with timbering as required. It may be necessary for runners or steel sheet piling to be driven ahead of the excavation work. This method can be used where weak subsoils are encountered so that the basement walls act as permanent timbering whilst the mound or dumping is excavated and the base slab cast. Perimeter trench excavations can also be employed in firm subsoils when the mechanical plant required for excavating the dumping is not available at the right time.

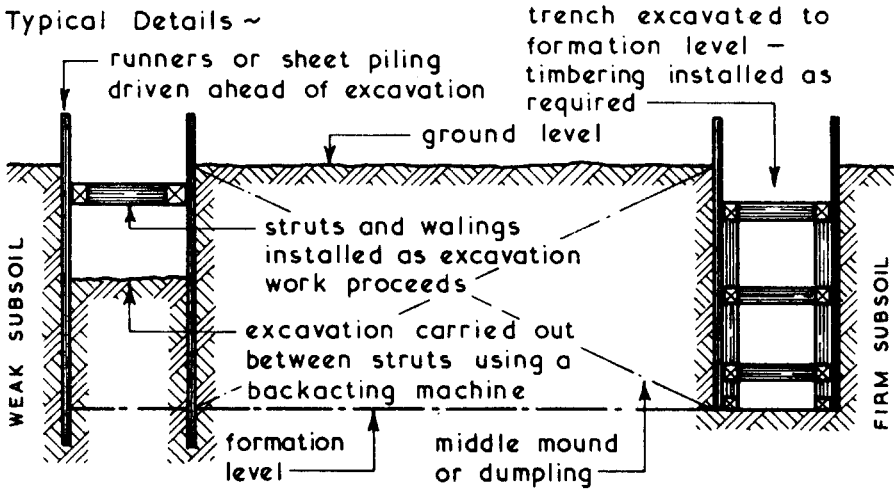

STAGE 1 - EXCAVATION OF PERIMETER TRENCH

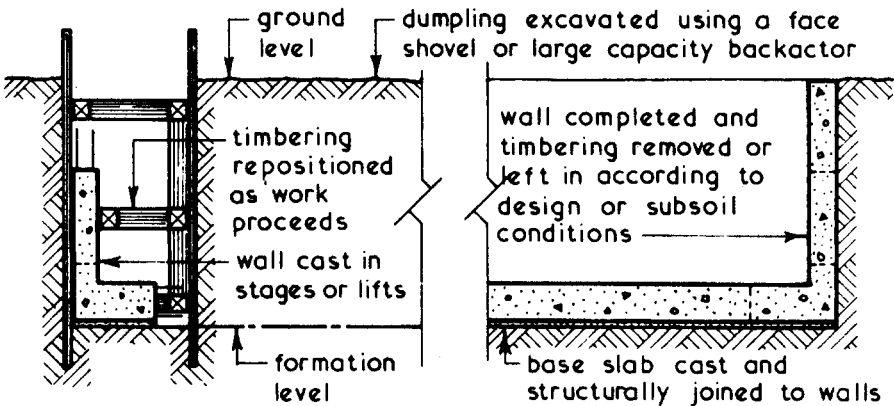

STAGE 2 - CONSTRUCTION OF BASEMENT WALLS

STAGE 3 - CONSTRUCTION OF BASEMENT SLAB

# Basement Excavations

Complete Excavation ~ this method can be used in firm subsoils where the centre of the proposed basement can be excavated first to enable the basement slab to be cast thus giving protection to the subsoil at formation level. The sides of excavation to the perimeter of the basement can be supported from the formation level using raking struts or by using raking struts pitched from the edge of the basement slab.

## Typical Details ~

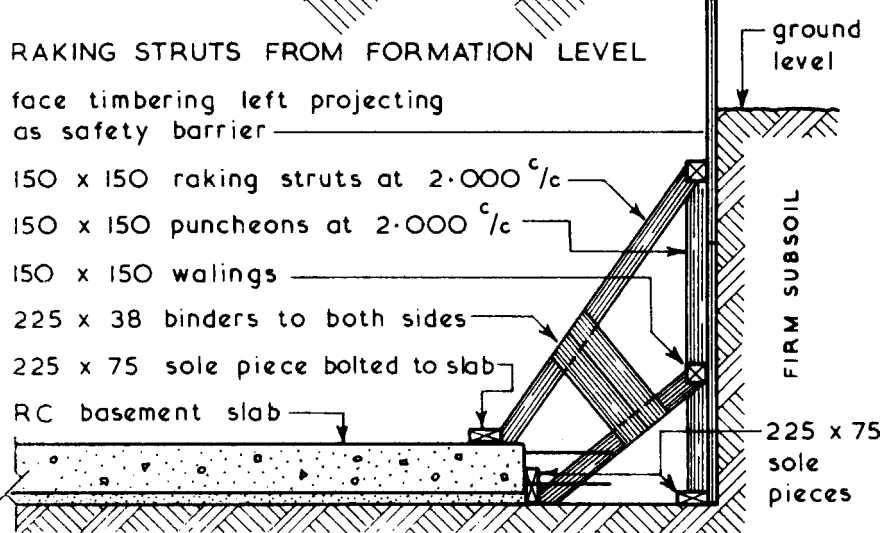
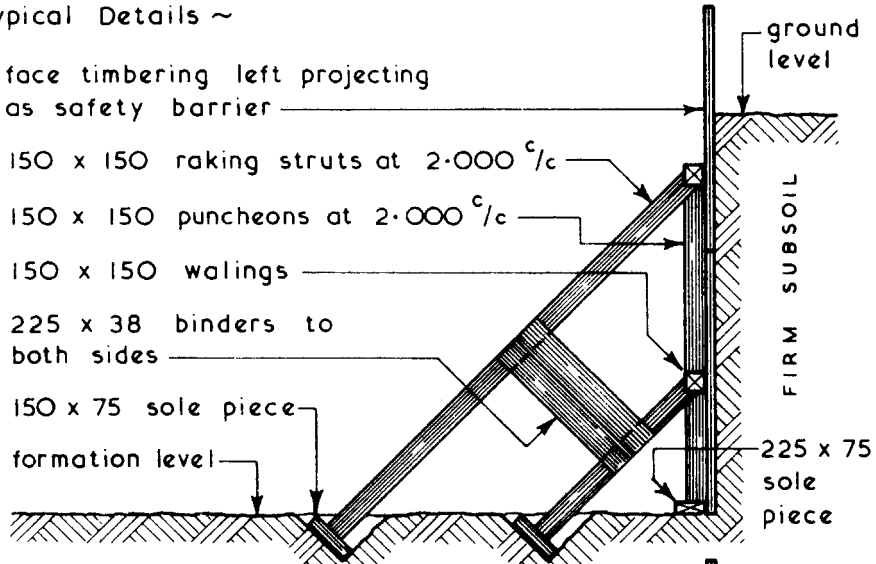

RAKING STRUTS FROM BASEMENT SLAB

Excavating Plant ~ the choice of actual pieces of plant to be used in any construction activity is a complex matter taking into account many factors. Specific details of various types of excavators are given on pages 209 to 213. At this stage it is only necessary to consider basic types for particular operations. In the context of basement excavation two forms of excavator could be considered.

1. Backactors - these machines are available as cable rigged or hydraulic excavators suitable for trench and bulk excavating. Cable rigged backactors are usually available with larger bucket sizes and deeper digging capacities than the hydraulic machines but these have a more positive control and digging operation and are also easier to operate.

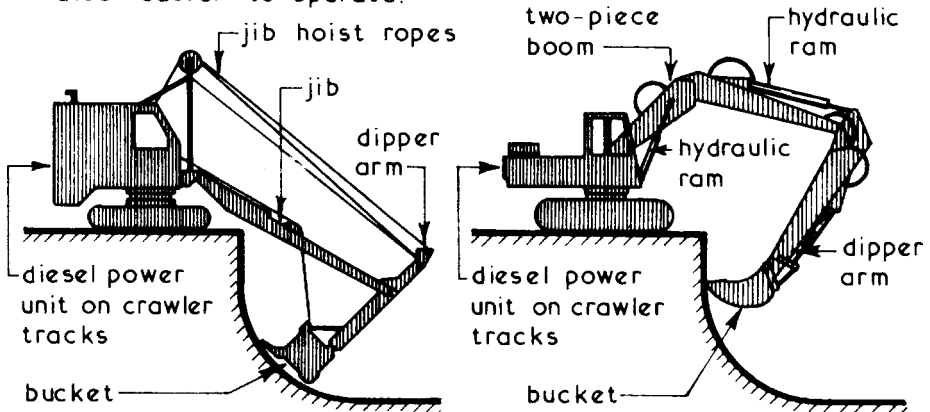

2. Face Shovels - these are robust machines designed to excavate above their own wheel or track level and are suitable for bulk excavation work. In basement work they will require a ramp approach unless they are to be lifted out of the excavation area by means of a crane. Like backactors face shovels are available as cable rigged or hydraulic machines.

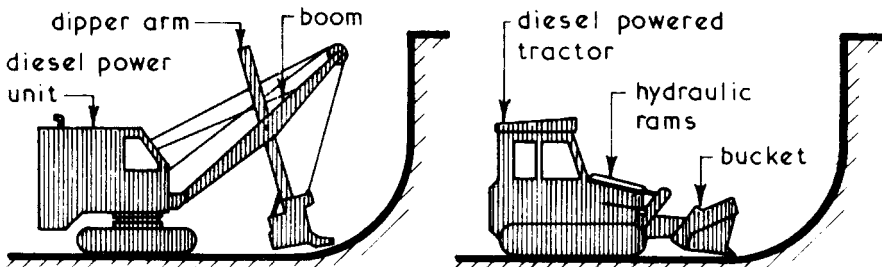



# Basement Construction

Basement Construction ~ in the general context of buildings a basement can be defined as a storey which is below the ground storey and is therefore constructed below ground level. Most basements can be classified into one of three groups:

1. Retaining Wall and Raft Basements - this is the general format for basement construction and consists of a slab raft foundation which forms the basement floor and helps to distribute the structural loads transmitted down the retaining walls.

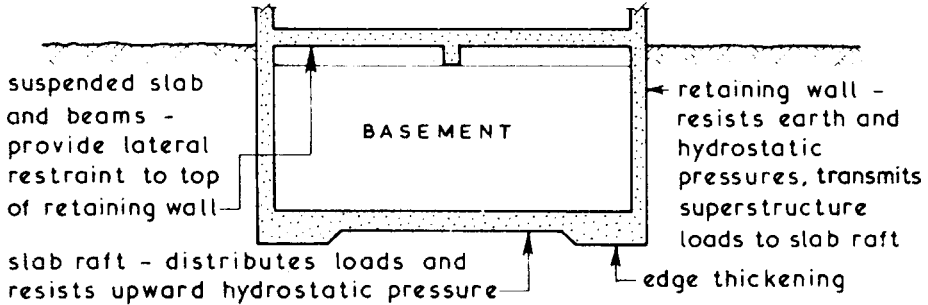

2. Box and Cellular Raft Basements - similar method to above except that internal walls are used to transmit and spread loads over raft as well as dividing basement into cells.

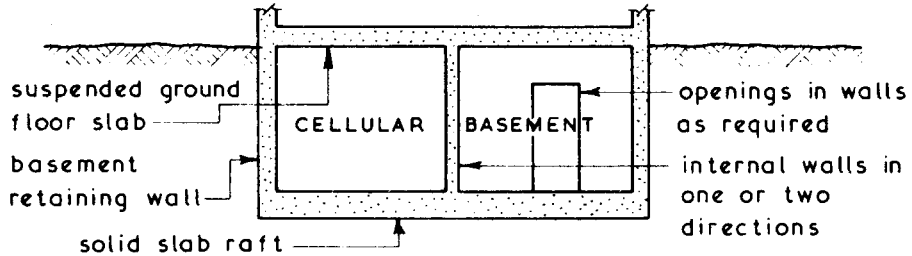

3. Piled Basements - the main superstructure loads are carried to the basement floor level by columns where they are finally transmitted to the ground via pile caps and bearing piles. This method can be used where low bearing capacity soils are found at basement floor level.

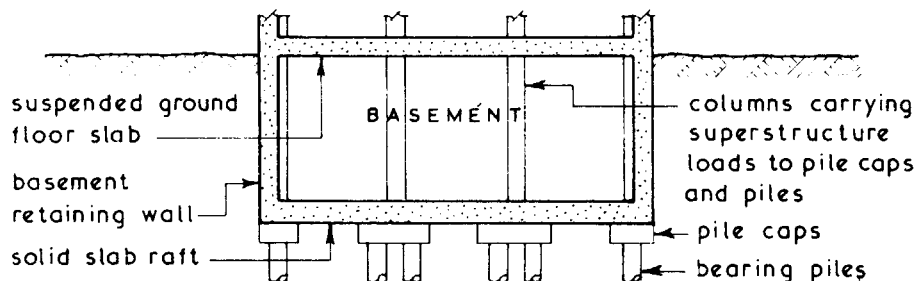

Deep Basement Construction ~ basements can be constructed within a cofferdam or other temporary supported excavation (see Basement Excavations on pages 304 to 306) up to the point when these methods become uneconomic, unacceptable or both due to the amount of necessary temporary support work. Deep basements can be constructed by installing diaphragm walls within a trench and providing permanent support with ground anchors or by using the permanent lateral support given by the internal floor during the excavation period (see next page). Temporary lateral support during the excavation period can be provided by lattice beams spanning between the diaphragm walls (see next page).

#### Typical Ground Anchor Support Details ~

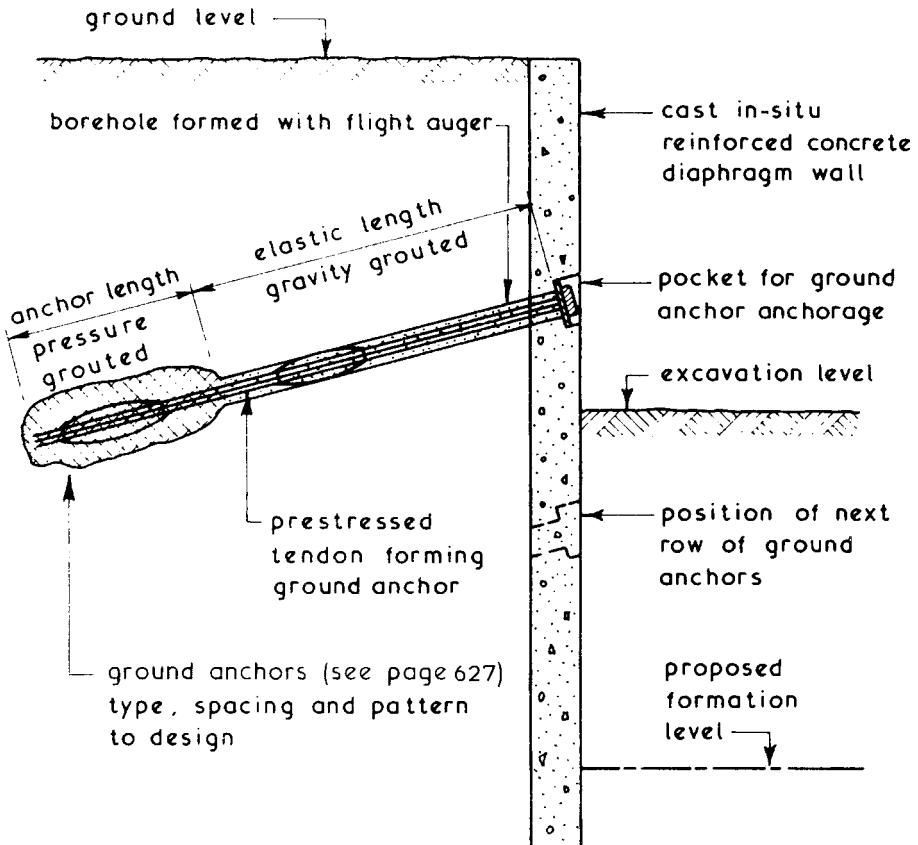

NB. vertical ground anchors installed through the lowest floor can be used to overcome any tendency to flotation during the construction period.

# Basement Construction

## Top down construction ~

### Basement Construction with Permanent Lateral Support

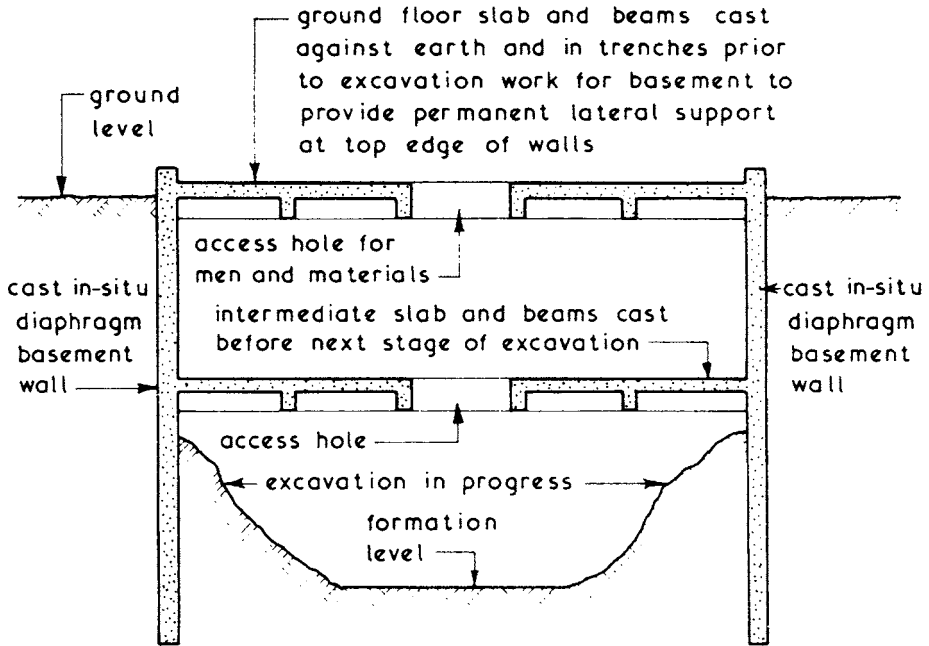

### Basement Construction with Temporary Lateral Support

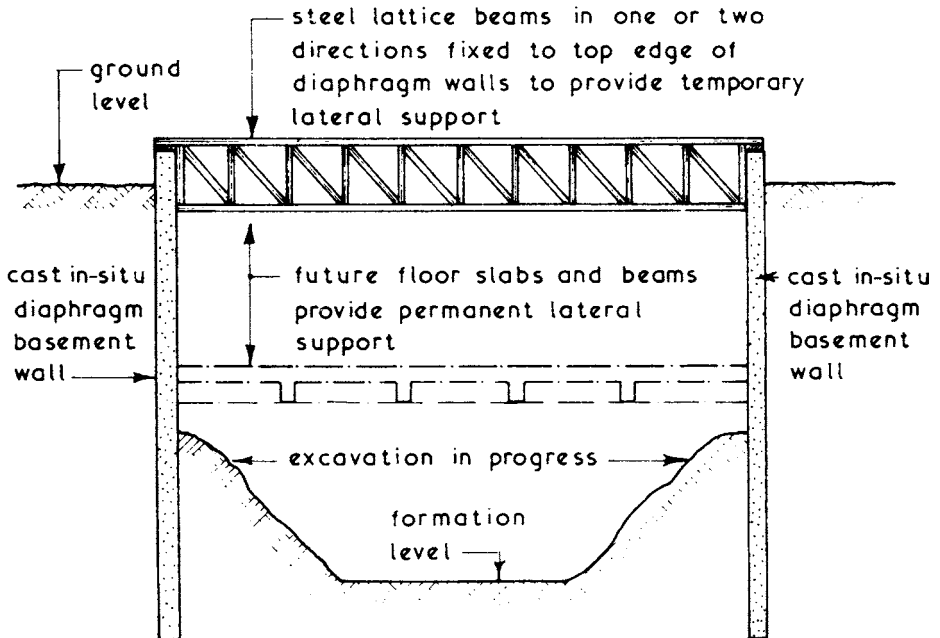

Top Down Construction with Superstructure ~ an extension of the principles outlined on the previous page where basement floors are constructed as excavation proceeds. Applied to construction of tall buildings, particularly in congested areas where existing buildings are in close proximity. Suited to deep basements where construction above ground can be conducted simultaneously with construction below ground, thereby optimising progress. Also suitable for underground car parks and railway stations.

Sequence Guidance (illustrated next page) ~

- Ground water controls/dewatering installed and activated (subject to sub-surface composition and water table height).
- Cast in-situ concrete diaphragm perimeter walls installed, possibly using contiguous or secant piling methods.
- Holes bored for piled foundations.
- Steel reinforcement cage positioned in boreholes.
- Load-bearing plunge columns (standard steel UC sections) lowered inside reinforcement cage.
- Boreholes concreted to ground level.
- In-situ reinforced concrete slab cast at ground level with shuttering to create suitable size opening(s) for excavation plant access. This and subsequent sub-floors act as lateral bracing to perimeter walls.
- Superstructure commences.
- Subsoil extracted through slab opening. Possible use of crane and bucket or long arm excavator. After initial soil removal, small backacters may be able to operate below ground floor slab.
- First basement formation level established and in-situ concrete floor slab cast with suitable size opening to access the next level down.
- Excavation procedure repeated to formation level of second basement floor and slab cast with access void if further sub-floors required.
- Continue until design depth and number of sub-floors is reached.
- Basement construction completed with waterproofing (tanking) and finishes.
- Continue with superstructural construction.

# Basement Construction

## Top Down Construction Principles Illustrated ~

### Diaphragm walls and plunge column piled foundation

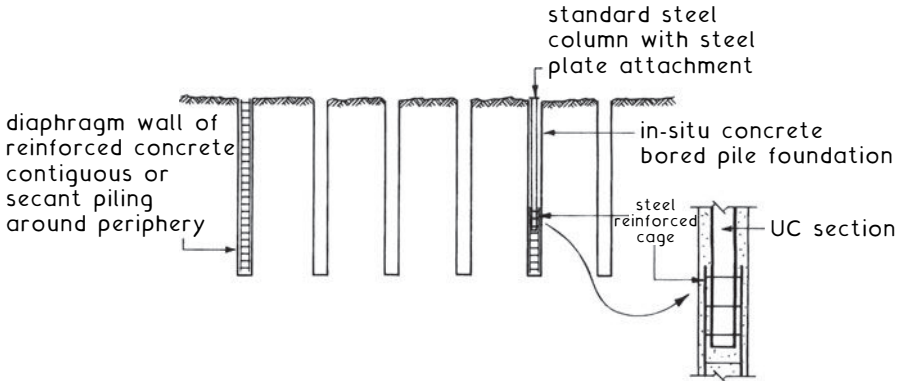

### Reinforced ground floor slab cast with access for excavation and commencement of superstructure

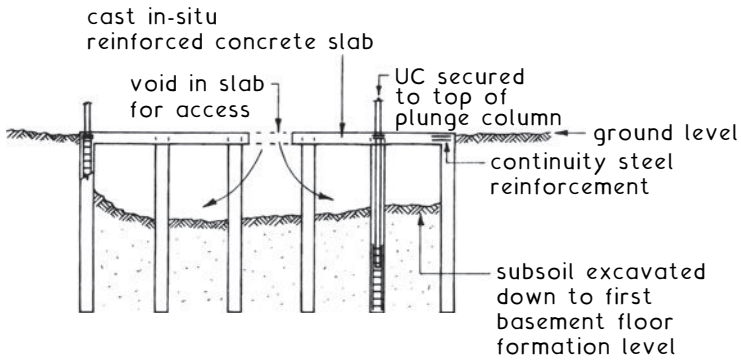

### Sub-floors concreted whilst superstructure proceeds

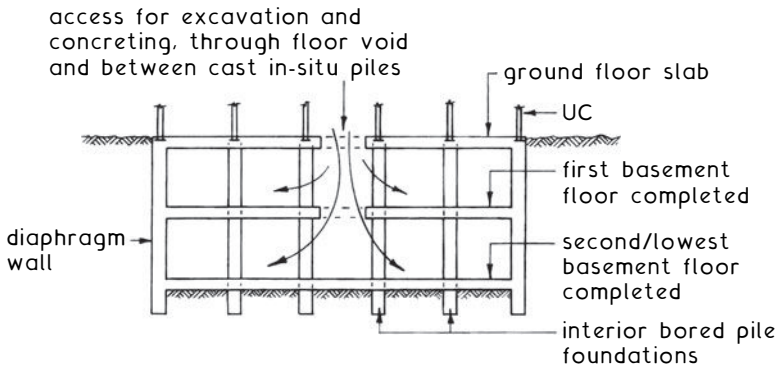

Waterproofing Basements ~ basements can be waterproofed by one of three basic methods, namely:

1. Use of dense monolithic concrete walls and floor.
2. Tanking techniques (see pages 315 and 316).
3. Drained cavity system (see page 317).

Dense Monolithic Concrete – the main objective is to form a watertight basement using dense high quality reinforced or prestressed concrete by a combination of good materials, good workmanship, attention to design detail and on-site construction methods. If strict control of all aspects is employed a sound, watertight structure can be produced but it should be noted that such structures are not always water vapourproof. If the latter is desirable some waterproof coating, lining or tanking should be used. The watertightness of dense concrete mixes depends primarily upon two factors:

1. Water/cement ratio.
2. Degree of compaction.

The hydration of cement during the hardening process produces heat; therefore to prevent early stage cracking the temperature changes within the hardening concrete should be kept to a minimum. The greater the cement content the more is the evolution of heat; therefore the mix should contain no more cement than is necessary to fulfil design requirements. Concrete with a free water/cement ratio of 0.5 is watertight and although the permeability is three times more at a ratio of 0.6 it is for practical purposes still watertight but above this ratio the concrete becomes progressively less watertight. For lower water/cement ratios the workability of the mix would have to be increased, usually by adding more cement, to enable the concrete to be fully compacted.

Admixtures – if the ingredients of good design, materials and workmanship are present watertight concrete can be produced without the use of admixtures. If admixtures are used they should be carefully chosen and used to obtain a specific objective:

1. Water-reducing admixtures – used to improve workability.
2. Retarding admixtures – slow down rate of hardening.
3. Accelerating admixtures – increase rate of hardening – useful for low temperatures – calcium chloride not suitable for reinforced concrete.
4. Water-repelling admixtures – effective only with low water head, will not improve poor-quality or porous mixes.
5. Air-entraining admixtures – increase workability – lower water content.

# Waterproofing Basements

Joints ~ in general these are formed in basement constructions to provide for movement accommodation (expansion joints) or to create a convenient stopping point in the construction process (construction joints). Joints are lines of weakness which will leak unless carefully designed and constructed; therefore they should be simple in concept and easy to construct.

Basement slabs ~ these are usually designed to span in two directions and as a consequence have relatively heavy top and bottom reinforcement. To enable them to fulfil their basic functions they usually have a depth in excess of 250mm. The joints, preferably of the construction type, should be kept to a minimum and if waterbars are specified they must be placed to ensure that complete compaction of the concrete is achieved.

## Typical Basement Slab Joint Details ~

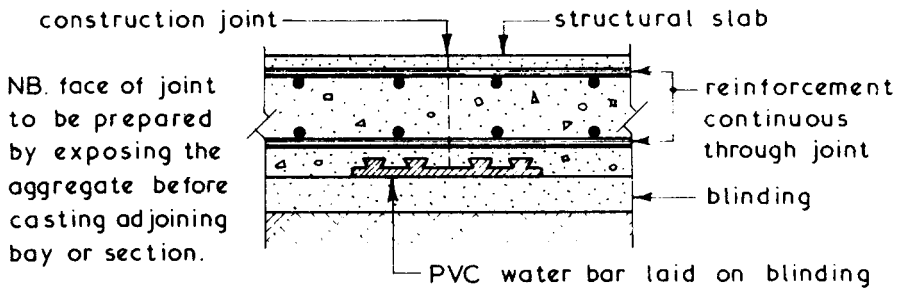

Basement Walls ~ joints can be horizontal and/or vertical according to design requirements. A suitable waterbar should be incorporated in the joint to prevent the ingress of water. The top surface of a kicker used in conjunction with single-lift pouring if adequately prepared by exposing the aggregate should not require a waterbar but if one is specified it should be either placed on the rear face or consist of a centrally placed mild steel strip inserted into the kicker whilst the concrete is still in a plastic state.

## Typical Basement Wall Joint Details ~

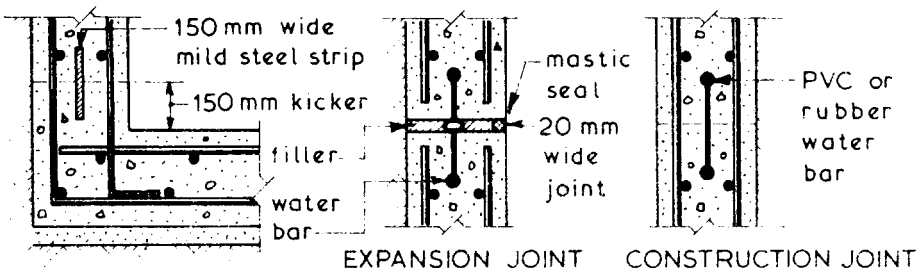

Mastic Asphalt Tanking ~ the objective of tanking is to provide a continuous waterproof membrane which is applied to the base slab and walls with complete continuity between the two applications. The tanking can be applied externally or internally according to the circumstances prevailing on site. Alternatives to mastic asphalt are polythene sheeting: bituminous compounds: epoxy resin compounds and bitumen laminates.

External Mastic Asphalt Tanking ~ this is the preferred method since it not only prevents the ingress of water but it also protects the main structure of the basement from aggressive sulphates which may be present in the surrounding soil or ground water.

Typical External Tanking Details ~

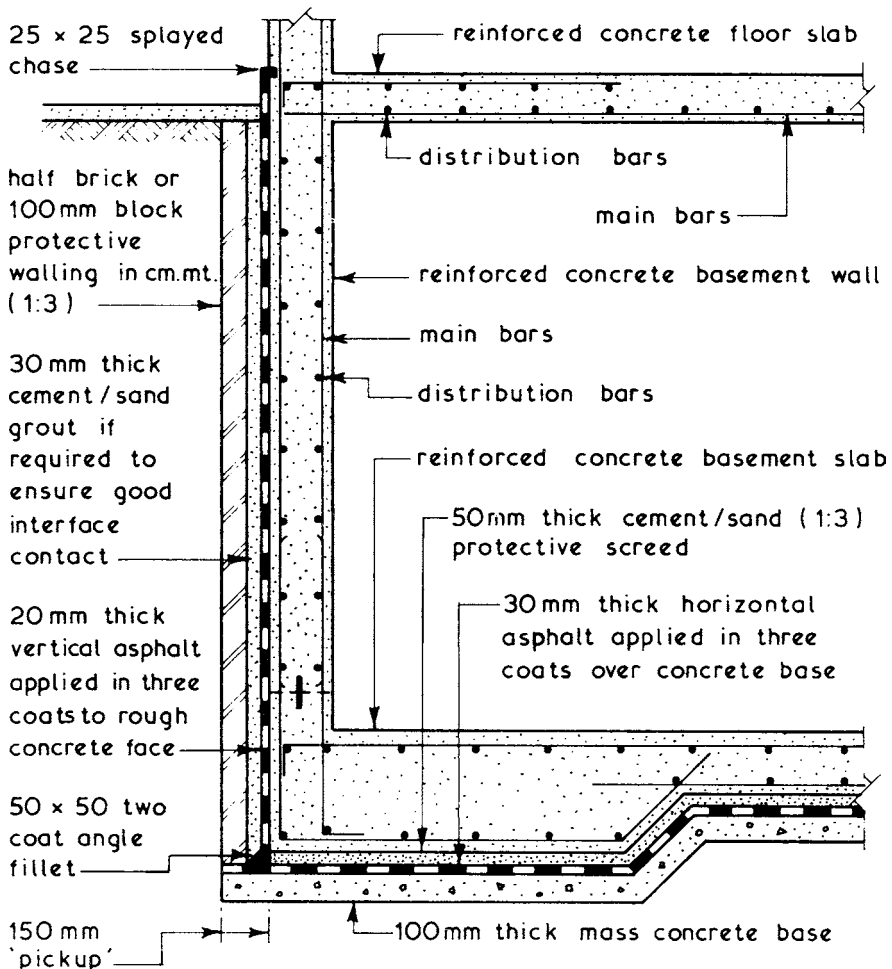



# Waterproofing Basements

Internal Mastic Asphalt Tanking ~ this method should only be adopted if external tanking is not possible since it will not give protection to the main structure and unless adequately loaded may be forced away from the walls and/or floor by hydrostatic pressure. To be effective the horizontal and vertical coats of mastic asphalt must be continuous.

## Typical Internal Tanking Details ~

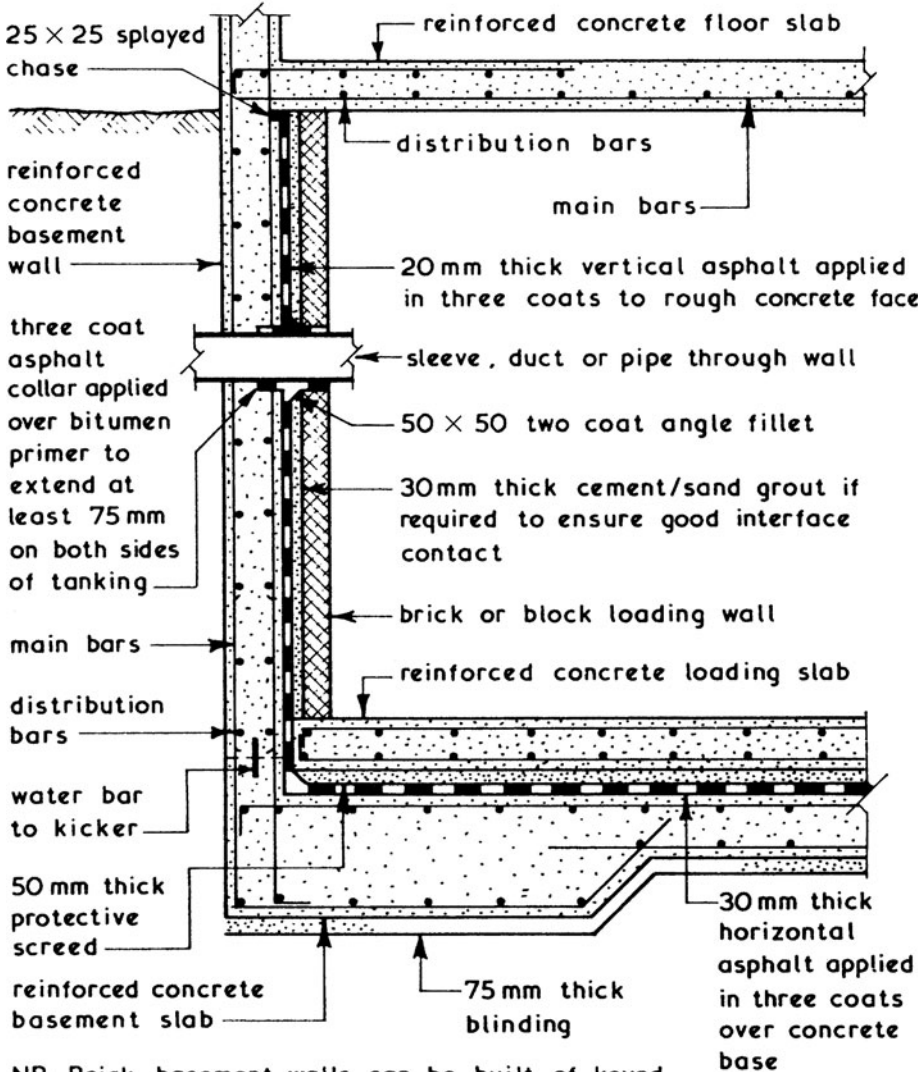

NB. Brick basement walls can be built of keyed bricks or the joints can be raked out to a depth of 20mm to provide key for asphalt tanking.

Drained Cavity System ~ this method of waterproofing basements can be used for both new and refurbishment work. The basic concept is very simple in that it accepts that a small amount of water seepage is possible through a monolithic concrete wall and the best method of dealing with such moisture is to collect it and drain it away. This is achieved by building an inner non-load-bearing wall to form a cavity which is joined to a floor composed of special triangular tiles laid to falls which enables the moisture to drain away to a sump from which it is either discharged direct or pumped into the surface water drainage system. The inner wall should be relatively vapour tight or alternatively the cavity should be ventilated.

### Typical Details ~

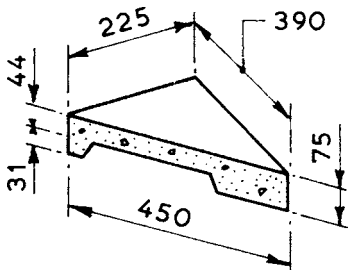

TOP VIEW - HALF TILE

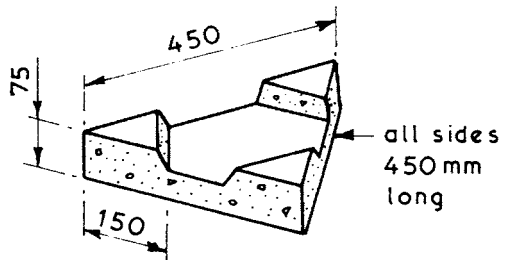

BOTTOM VIEW - STANDARD TILE

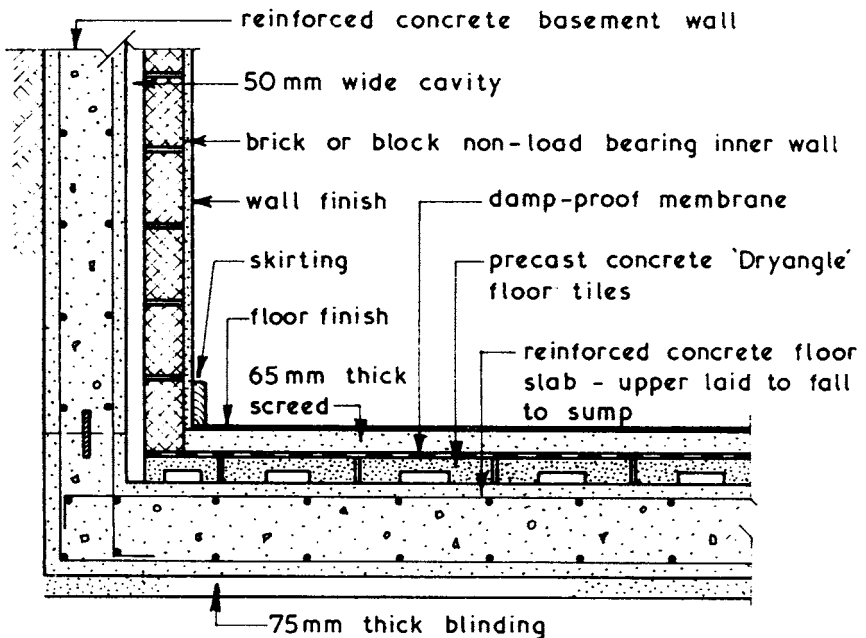

## Insulation of Basements

Basements benefit considerably from the insulating properties of the surrounding soil. However, that alone is insufficient to satisfy the typical requirements for wall and floor U-values of 0.35 and 0.25 W/m<sup>2</sup>K, respectively.

Refurbishment of existing basements may include insulation within dry lined walls and under-the-floor screed or particle board overlay. This should incorporate an integral vapour control layer to minimise risk of condensation.

External insulation of closed cell rigid polystyrene slabs is generally applied to new construction. These slabs combine low thermal conductivity with low water absorption and high compressive strength. The external face of insulation is grooved to encourage moisture run-off. It is also filter faced to prevent clogging of the grooves. Backfill is granular.

### Typical application ~

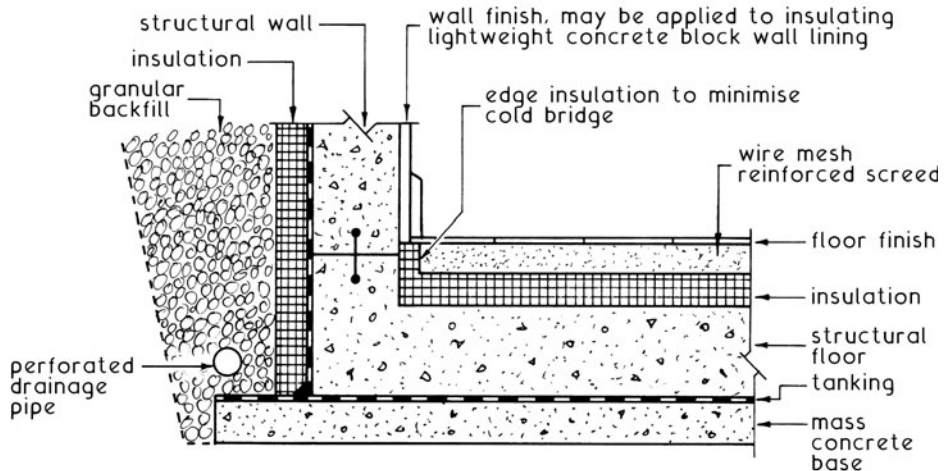

Note: reinforcement in concrete omitted, see details on previous pages.

Tables and calculation methods to determine heat energy transfer for basements are provided in BS EN ISO 13370: Thermal performance of buildings. Heat transfer via the ground. Calculation methods.

Excavation ~ to hollow out - in building terms to remove earth to form a cavity in the ground.

### Types of Excavation ~

**Oversite** - the removal of topsoil (Building Regulations requirement).

depth varies from site to site but is usually in a 150 to 300mm range. Topsoil contains plant life, animal life and decaying matter which makes the soil compressible and therefore unsuitable for supporting buildings.



**Reduce Level** - carried out below over-site level to form a level surface on which to build and can consist of both cutting and filling operations. The level to which the ground is reduced is called the formation level.

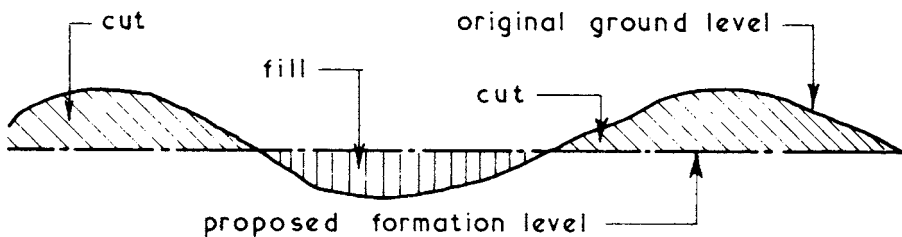

NB. Water in Excavations - this should be removed since it can:

1. Undermine sides of excavation.
2. Make it impossible to adequately compact bottom of excavation to receive foundations.
3. Cause puddling which can reduce the bearing capacity of the subsoil.

# Excavations

Trench Excavations ~ narrow excavations primarily for strip foundations and buried services - excavation can be carried out by hand or machine.

Typical Examples ~

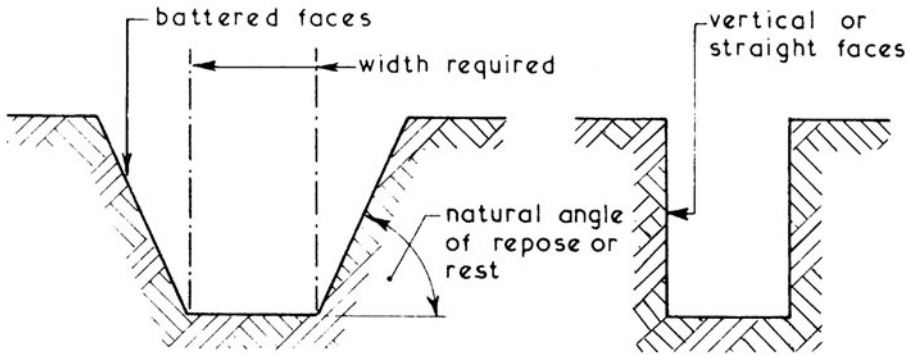

Disadvantage ~ extra cost of over-excavating and extra backfilling.

Advantage ~ no temporary support required to sides of excavation.

Disadvantage ~ sides of excavation may require some degree of temporary support.

Advantage ~ minimum amount of soil removed and therefore minimum amount of backfilling.

Pier Holes ~ isolated pits primarily used for foundation pads for columns and piers or for the construction of soakaways.

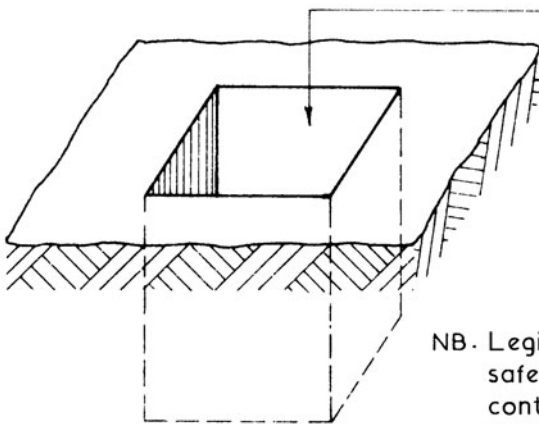

sides of excavation can be battered or straight as described above - deep pier holes may have to be over-excavated in plan to provide good access to and good egress from the working area for both men and materials.

NB. Legislation affecting safety in excavation is contained in the Construction (Design and Management) Regulations.

## Excavations up to 2.5 m deep – Processes

### Site Clearance and Removal of Topsoil ~

On small sites this could be carried out by manual means using handheld tools such as picks, shovels and wheelbarrows.

On all sites mechanical methods could be used, the actual plant employed being dependent on factors such as volume of soil involved, nature of site and time elements.

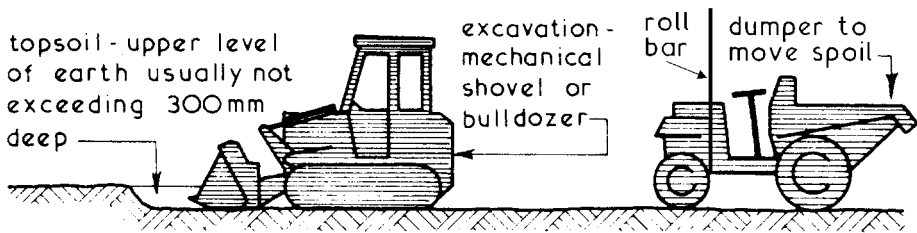

### Reduced Level Excavations ~

On small sites – hand processes as given above.

On all sites mechanical methods could be used dependent on factors given above.

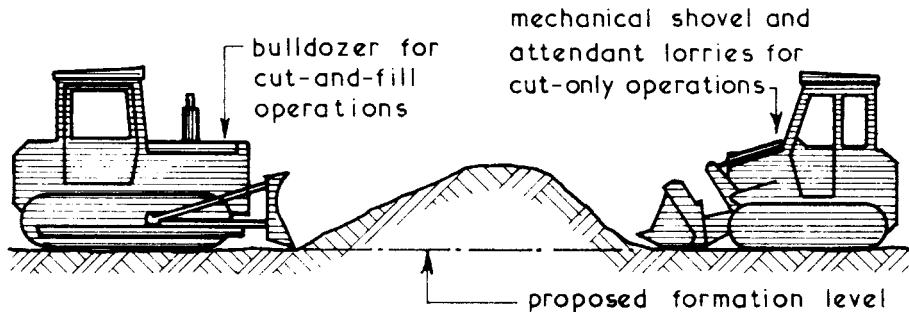

### Trench and Pit Excavations ~

On small sites – hand processes as given above but if depth of excavation exceeds 1:200 some method of removing spoil from the excavation will have to be employed.

On all sites mechanical methods could be used dependent on factors given above.

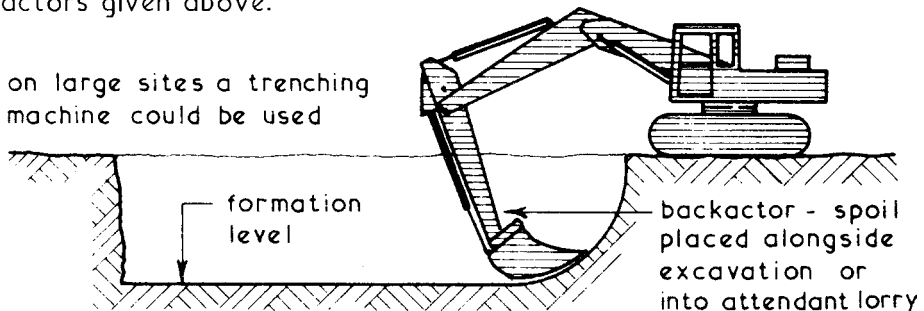

on large sites a trenching machine could be used

## Excavations up to 2.5m deep – Temporary Support

All subsoils have different abilities in remaining stable during excavation works. Most will assume a natural angle of repose or rest unless given temporary support. The presence of ground water apart from creating difficult working conditions can have an adverse effect on the subsoil's natural angle of repose.

### Typical Angles of Repose ~

Excavations cut to a natural angle of repose are called battered.

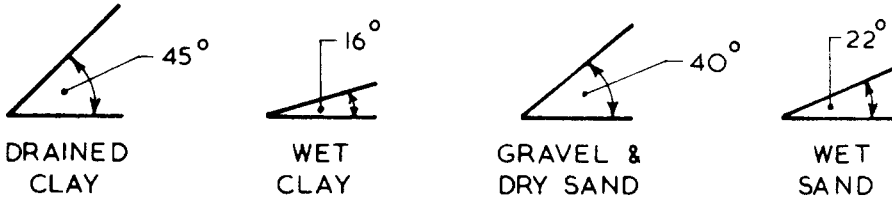

### Factors for Temporary Support of Excavations ~

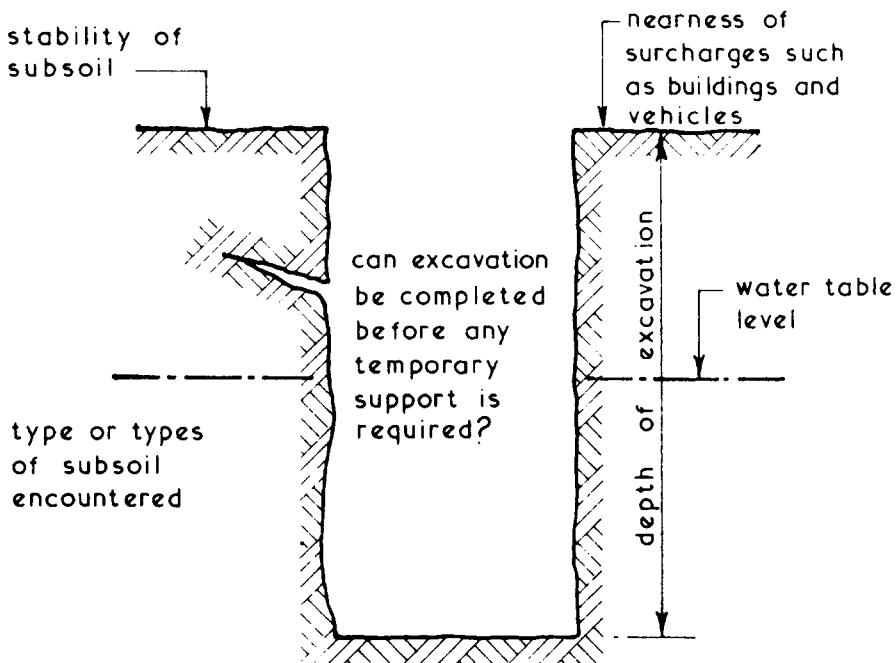

Time factors such as period during which excavation will remain open and the time of year when work is carried out.

The need for an assessment of risk with regard to the support of excavations and protection of people within is a legal responsibility under the Health and Safety at Work, etc. Act and the Construction (Design and Management) Regulations.

## Excavations up to 2.5m deep – Temporary Support

Temporary Support ~ in the context of excavations this is called timbering irrespective of the actual materials used. If the sides of the excavation are completely covered with timbering it is known as close timbering whereas any form of partial covering is called open timbering.

An adequate supply of timber or other suitable material must be available and used to prevent danger to any person employed in an excavation from a fall or dislodgement of materials forming the sides of an excavation.

A suitable barrier or fence must be provided to the sides of all excavations or alternatively they must be securely covered.

Materials must not be placed near to the edge of any excavation, nor must plant be placed or moved near to any excavation so that persons employed in the excavation are endangered.

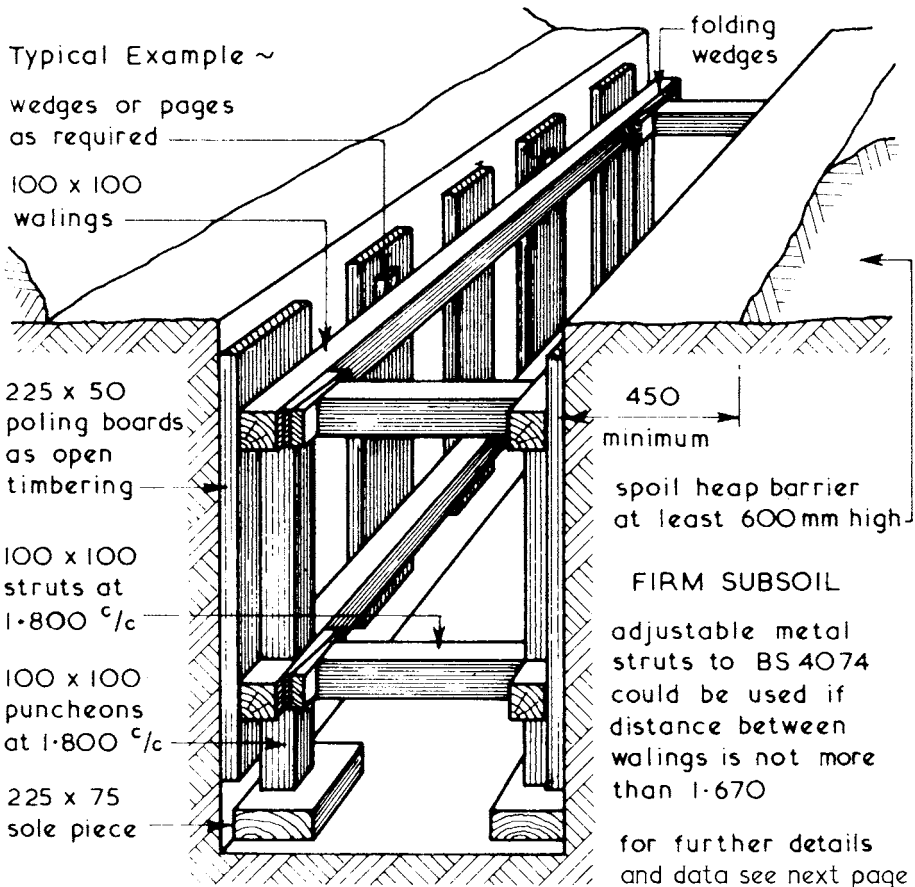



## Excavations up to 2.5m deep – Temporary Support

Poling Board ~ a form of temporary support which is placed in position against the sides of excavation after the excavation work has been carried out. Poling boards are placed at centres according to the stability of the subsoils encountered.

Runner ~ a form of temporary support which is driven into position ahead of the excavation work either to the full depth or by a drive-and-dig technique where the depth of the runner is always lower than that of the excavation.

Trench Sheet piling ~ form of runner made from sheet steel with a trough profile – can be obtained with a lapped joint or an interlocking joint.

Water ~ if present or enters an excavation, a pit or sump should be excavated below the formation level to act as a collection point from which the water can be pumped away.

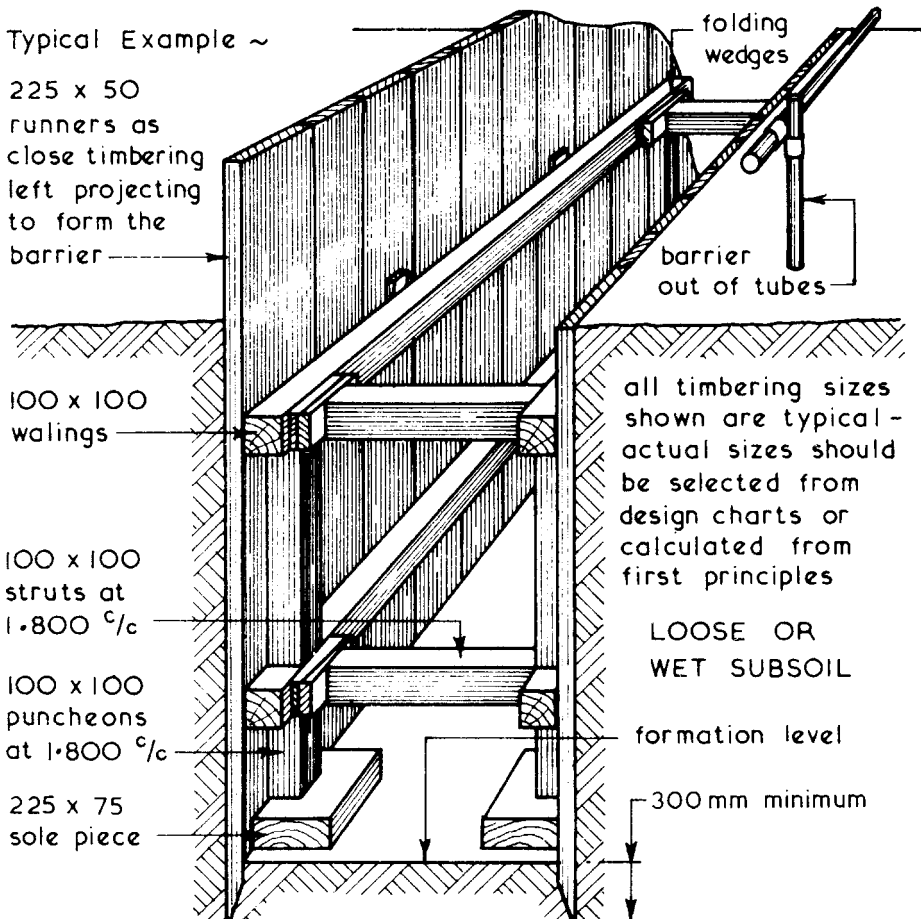

Concrete ~ a mixture of cement + fine aggregate + coarse aggregate + water in controlled proportions and of a suitable quality.

Cement ~



BAGS



SILOS

powder produced from clay and chalk or limestone. In general most concrete is made with ordinary or rapid hardening Portland cement, both types being manufactured to the recommendations of BS EN 197-1. Ordinary Portland cement is adequate for most purposes but has a low resistance to attack by acids and sulphates. Rapid hardening Portland cement does not set faster than ordinary Portland cement but it does develop its working strength at a faster rate. For a concrete which must have an acceptable degree of resistance to sulphate attack, the quantity of tricalcium aluminate is reduced during the manufacture of Portland cement (4% instead of 10% in OPC). BS EN 15743 contains reference to this type of sulphate-resisting cement.

Aggregates ~

coarse aggregate

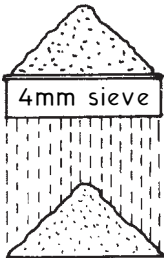

fine aggregate

shape, surface texture and grading (distribution of particle sizes) are factors which influence the workability and strength of a concrete mix. Fine aggregates are generally regarded as those materials which pass through a 4mm sieve whereas coarse aggregates are retained on a 4mm sieve. Dense aggregates have a density of more than  $1200\text{kg/m}^3$  for coarse aggregates and more than  $1250\text{kg/m}^3$  for fine aggregates. These are detailed in BS EN 12620: Aggregates for concrete. Lightweight aggregates include clinker; foamed or expanded blastfurnace slag and exfoliated and expanded materials such as vermiculite, perlite, clay and sintered pulverised fuel ash to BS EN 13055-1.

Water ~

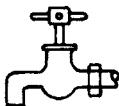

drinking water quality

must be clean and free from impurities which are likely to affect the quality or strength of the resultant concrete. Pond, river, canal and sea water should not be used and only water which is fit for drinking should be specified.

## Concrete Production – Site Storage of Materials

Cement ~ whichever type of cement is being used it must be properly stored on site to keep it in good condition. The cement must be kept dry since contact with any moisture whether direct or airborne could cause it to set. A rotational use system should be introduced to ensure that the first batch of cement delivered is the first to be used.

### Typical Storage Methods ~

polythene or similar waterproof cover

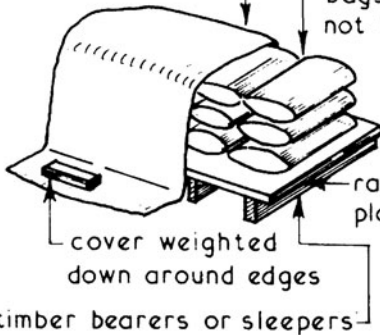

cover weighted down around edges

SMALL CONTRACTS

stored cement bags - total height not more than 1.000

well fitted lockable doors

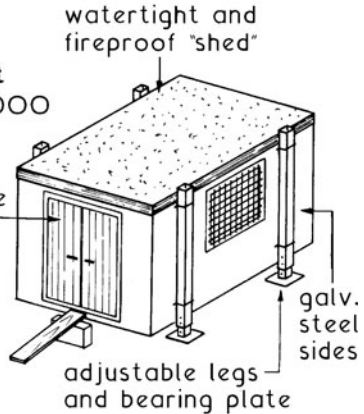

watertight and fireproof "shed"

galv. steel sides

adjustable legs and bearing plate

MEDIUM SIZE CONTRACTS

LARGE CONTRACTS – for bagged cement watertight container as above. For bulk delivery loose cement, a cement storage silo.

Aggregates ~ essentials of storage are to keep different aggregate types and/or sizes separate, store on a clean, hard, free draining surface and to keep the stored aggregates clean and free of leaves and rubbish.

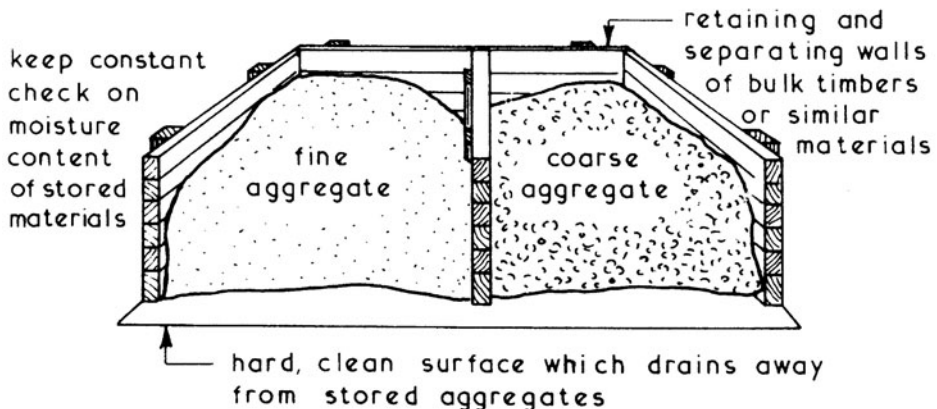

keep constant check on moisture content of stored materials

retaining and separating walls of bulk timbers or similar materials

fine aggregate

coarse aggregate

hard, clean surface which drains away from stored aggregates

Concrete Batching ~ a batch is one mixing of concrete and can be carried out by measuring the quantities of materials required by volume or weight. The main aim of both methods is to ensure that all consecutive batches are of the same standard and quality.

Volume Batching ~ concrete mixes are often quoted by ratio such as 1:2:4 (cement : fine aggregate or sand : coarse aggregate). Cement weighing 50 kg has a volume of 0.033 m<sup>3</sup>; therefore for the above mix 2 × 0.033 (0.066 m<sup>3</sup>) of sand and 4 × 0.033 (0.132 m<sup>3</sup>) of coarse aggregate is required. To ensure accurate amounts of materials are used for each batch a gauge box should be employed, its size being based on convenient handling. Ideally a batch of concrete should be equated to using 50 kg of cement per batch. Assuming a gauge box 300 mm deep and 300 mm wide with a volume of half the required sand the gauge box size would be -  
 volume = length × width × depth = length × 300 × 300.

$$\text{length} = \frac{\text{volume}}{\text{width} \times \text{depth}} = \frac{0.033}{0.3 \times 0.3} = 0.366 \text{ m}$$

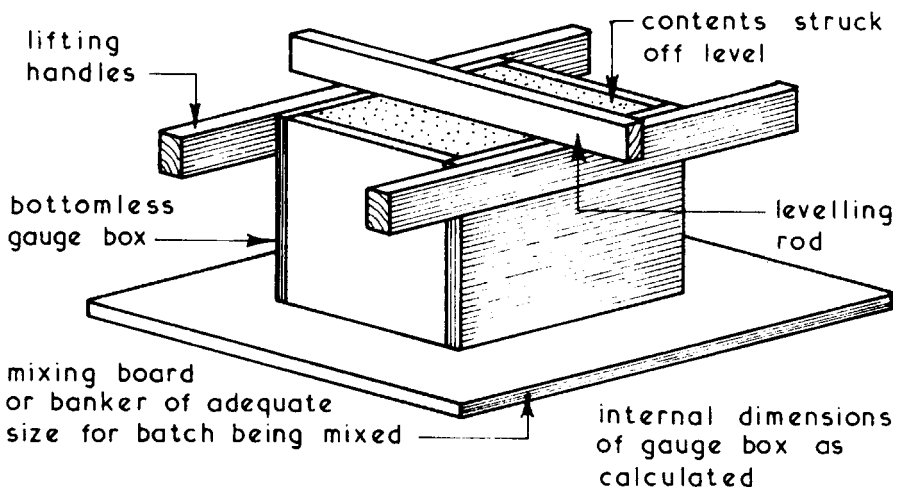

For the above given mix fill gauge box once with cement, twice with sand and four times with coarse aggregate.

An allowance must be made for the bulking of damp sand which can be as much as 33⅓%. General rule of thumb unless using dry sand: allow for 25% bulking.

Materials should be well mixed dry before adding water.

## Concrete Production – Weight (Weigh) Batching

Weight or Weigh Batching ~ this is a more accurate method of measuring materials for concrete than volume batching since it reduces considerably the risk of variation between different batches. The weight of sand is affected very little by its dampness which in turn leads to greater accuracy in proportioning materials. When loading a weighing hopper the materials should be loaded in a specific order:

1. Coarse aggregates - tend to push other materials out and leave the hopper clean.
2. Cement - this is sandwiched between the other materials since some of the fine cement particles could be blown away if cement is put in last.
3. Sand or fine aggregates - put in last to stabilise the fine lightweight particles of cement powder.

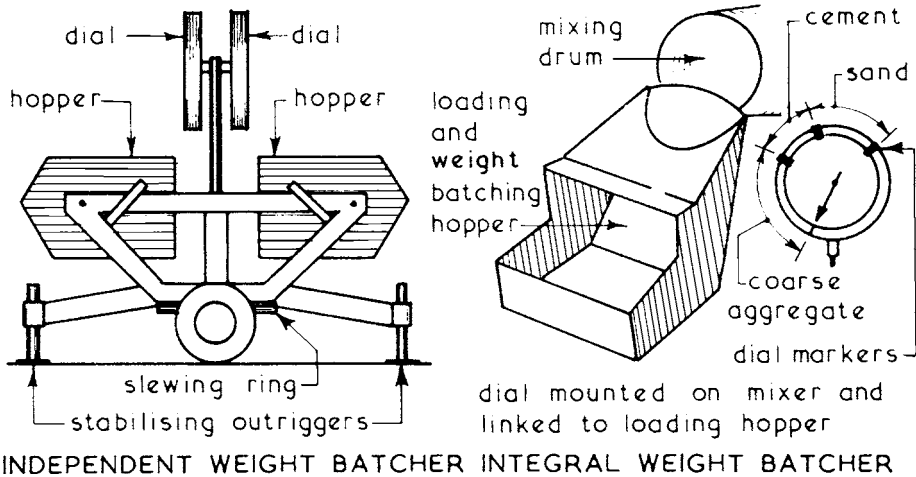

Typical Densities ~ cement -  $1440 \text{ kg/m}^3$  sand -  $1600 \text{ kg/m}^3$  coarse aggregate -  $1440 \text{ kg/m}^3$

Water/Cement Ratio ~ water in concrete has two functions:

1. Starts the chemical reaction which causes the mixture to set into a solid mass.
2. Gives the mix workability so that it can be placed, tamped or vibrated into the required position.

Very little water is required to set concrete (approximately 0.2 w/c ratio) and the surplus evaporates leaving minute voids; therefore the more water added to the mix to increase its workability the weaker is the resultant concrete. Generally w/c ratios of 0.4 to 0.5 are adequate for most purposes. See next page.

## Concrete Production – Water/Cement Ratio

Free Water ~ water on the surface of aggregates where stored in stock piles plus water added during the mixing process. Does not include any water that is absorbed by the aggregate.

Free Water/Cement Ratio ~ a high w/c ratio increases the workability of concrete. This may be convenient for placing but it should be controlled in order to regulate the final concrete strength.

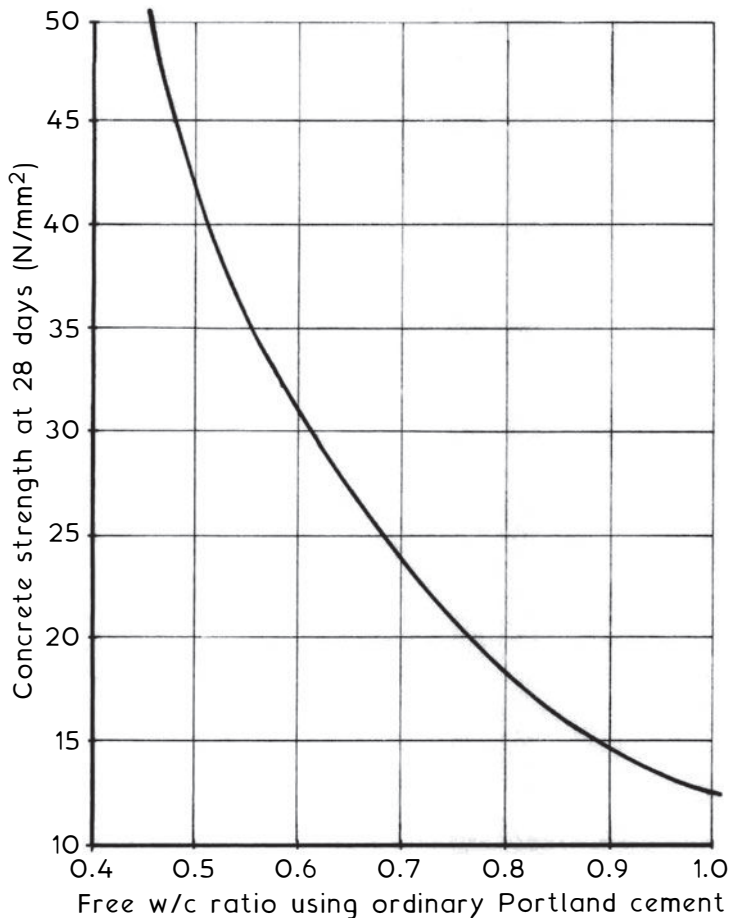

Note: The w/c ratio is found by dividing the weight of water in a batch by the weight of cement. E.g. If a batch contains 50 kg of water and 100 kg of cement, the w/c ratio is 0.5.

## Concrete Production – Specification

Concrete ~ a composite with many variables, represented by numerous gradings which indicate components, quality and manufacturing control.

Grade mixes: C7.5, C10, C15, C20, C25, C30, C35, C40, C45, C50, C55 and C60; F3, F4 and F5; IT2, IT2.5, and IT3.

C = Characteristic compressive  
F = Flexural  
IT = Indirect tensile

} strengths at 28 days (N/mm<sup>2</sup>)

NB. If the grade is followed by a 'P', e.g. C30P, this indicates a prescribed mix (see below).

Grades C7.5 and C10 - Unreinforced plain concrete.

Grades C15 and C20 - Plain concrete or if reinforced containing lightweight aggregate.

Grades C25 - Reinforced concrete containing dense aggregate.

Grades C30 and C35 - Post-tensioned reinforced concrete.

Grades C40 to C60 - Pre-tensioned reinforced concrete.

Categories of mix:

1. Prescribed Mix - components are predetermined (to a recipe) to ensure strength requirements. Variations exist to allow the purchaser to specify particular aggregates, admixtures and colours. All grades permitted.

2. Standard Prescribed Mix - applicable to minor works such as house construction, particularly where weight or volume batching is used for small quantities. See next page for standard (ST) mixes with C30 strength class concrete.

3. Designed Mix - concrete is specified to an expected performance. Criteria can include characteristic strength, durability and workability, to which a concrete manufacturer will design and supply an appropriate mix. All grades permitted.

4. Designated Mix - selected for specific applications. General (GEN) graded 0-4, 7.5-25 N/mm<sup>2</sup> for foundations, floors and external works. Foundations (FND) graded 2, 3, 4A and 4B, 35N/mm<sup>2</sup> mainly for sulphate resisting foundations.

Paving (PAV) graded 1 or 2, 35 or 45 N/mm<sup>2</sup> for roads and drives.

Reinforced (RC) graded 30, 35, 40, 45 and 50 N/mm<sup>2</sup> mainly for pre-stressing.

See also BS EN 206-1: Concrete. Specification, performance, production and conformity, and BS's 8500-1 and -2: Concrete.

## Concrete Production – Site Mixed Specification

Standard prescribed mixes for site batching are graded for concrete with a characteristic compressive strength of 30 N/mm<sup>2</sup> at 28 days. Compressive strength is achieved by laboratory testing sample cubes as detailed on page 136.

### Weight Batched Proportions ~

Standard prescribed mix	Consistence class (slump)	Cement bag (kg)	Fine agg. (kg)	Coarse agg. (kg) max. 20 mm	Mix ratio
ST1	S1	25	84	126	1:3.35:5.02
ST2	S2	25	72	107	1:2.87:4.28
ST2	S3	25	65	97	1:2.58:3.88
ST2	S4	25	68	83	1:2.72:3.30
ST3	S2	25	63	95	1:2.52:3.80
ST4	S2	25	56	83	1:2.23:3.33
ST5	S2	25	48	72	1:1.92:2.88

### Volume Batched Proportions~

Standard prescribed mix	Consistency class (slump)	Cement bag (kg)	Fine agg. (litres)	Coarse agg. (litres)
ST1	S1	25	60	85
ST2	S2	25	50	75
ST2	S3	25	45	70
ST2	S4	25	50	60
ST3	S2	25	45	65

Consistency Class ~ this refers to the amount of water in the mix, affecting workability and final strength. See page 135.

Consistency class	Slump (mm)
S1	10 - 40
S2	50 - 90
S3	100 - 150
S4	160 - 210



## Concrete Production – Supply

Concrete Supply ~ this is usually geared to the demand or the rate at which the mixed concrete can be placed. Fresh concrete should always be used or placed within 30 minutes of mixing to prevent any undue drying out. Under no circumstances should more water be added after the initial mixing.

Small Batches ~ small, easily transported mixers with output capacities of up to 100 litres can be used for small and intermittent batches. These mixers are versatile and robust machines which can be used for mixing mortars and plasters as well as concrete.

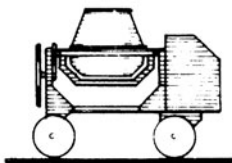

Medium to Large Batches ~ mixers with output capacities from 100 litres to 10m<sup>3</sup> with either diesel or electric motors. Many models are available with tilting or reversing drum discharge, integral weigh batching and loading hopper and a controlled water supply.

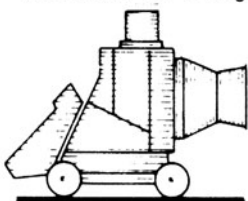

Ready Mixed Concrete ~ used mainly for large concrete batches of up to 6 m<sup>3</sup>. This method of concrete supply has the advantages of eliminating the need for site space to accommodate storage of materials, mixing plant and the need to employ adequately trained site staff who can constantly produce reliable and consistent concrete mixes. Ready mixed concrete supply depots also have better facilities and arrangements for producing and supplying mixed concrete in winter or inclement weather conditions. In many situations it is possible to place the ready mixed concrete into the required position direct from the delivery lorry via the delivery chute or by feeding it into a concrete pump. The site must be capable of accepting the 20 tonnes laden weight of a typical ready mixed concrete lorry with a turning circle of about 15·000. The supplier will want full details of mix required and the proposed delivery schedule.

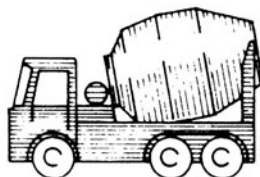

Ref. BS EN 206-1: Concrete. Specification, performance, production and conformity.

Cofferdams ~ these are temporary enclosures installed in soil or water to prevent the ingress of soil and/or water into the working area with the cofferdam. They are usually constructed from interlocking steel sheet piles which are suitably braced or tied back with ground anchors. Alternatively a cofferdam can be installed using any structural material which will fulfil the required function.

#### Typical Cofferdam Details ~

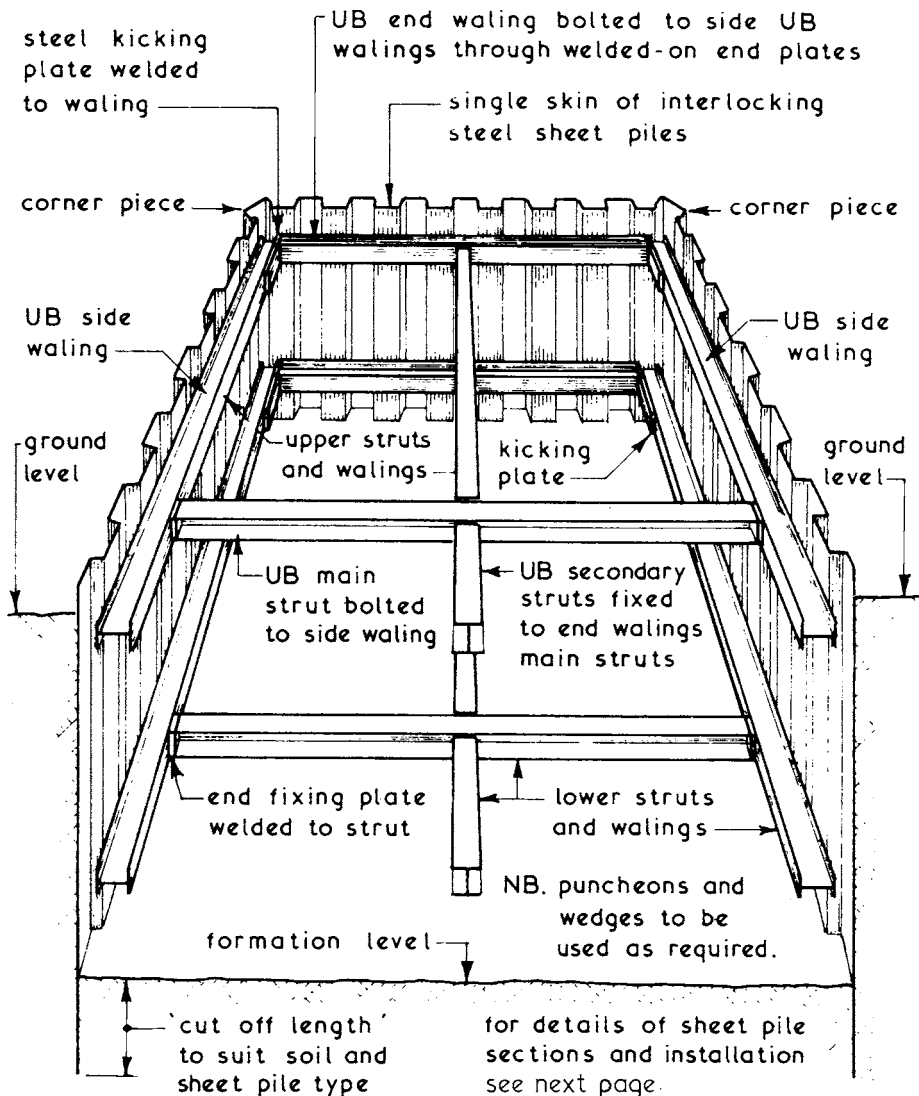

# Cofferdams – Steel Sheet Piling

Steel Sheet Piling ~ apart from cofferdam work, steel sheeting can be used in excavations and to form permanent retaining walls. Three common formats of steel sheet piles with interlocking joints are available with a range of section sizes and strengths up to a maximum length of 30 m.

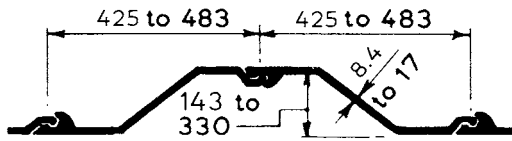

**FRODINGHAM SHEET PILES (general use)**

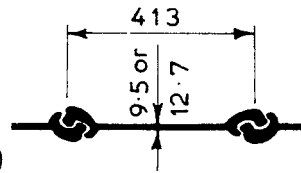

**STRAIGHT WEB (circular work)**

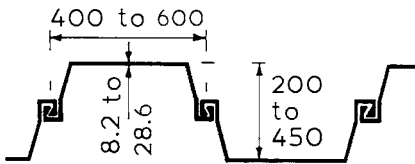

**LARSEN SHEET PILES (general use)**

all piles supplied with lifting or slinging holes positioned in top end of pile

Installing Steel Sheet Piles ~ to ensure that the sheet piles are pitched and installed vertically a driving trestle or guide frame is used. These are usually purpose built to accommodate a panel of 10 to 12 pairs of piles. The piles are lifted into position by a crane and driven by means of a percussion piling hammer or alternatively they can be pushed into the ground by hydraulic rams acting against the weight of the power pack which is positioned over the heads of the pitched piles.

## Typical Installation Details ~

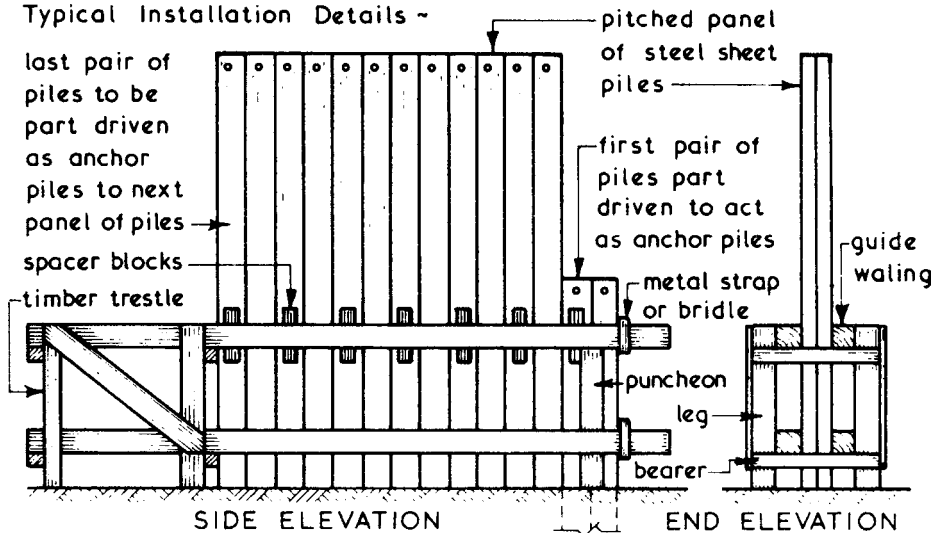

Note: Rot-proof PVC sheet piling is also available.

## Steel Sheet Piling – Installation

Alternative guide rail support system to that shown on the preceding page. This uses standard steel sections with components bolted together for simple assembly and dismantling. Tack welding is an option instead of bolting, with welds removed by angle grinder for dismantling on completion of pile driving.

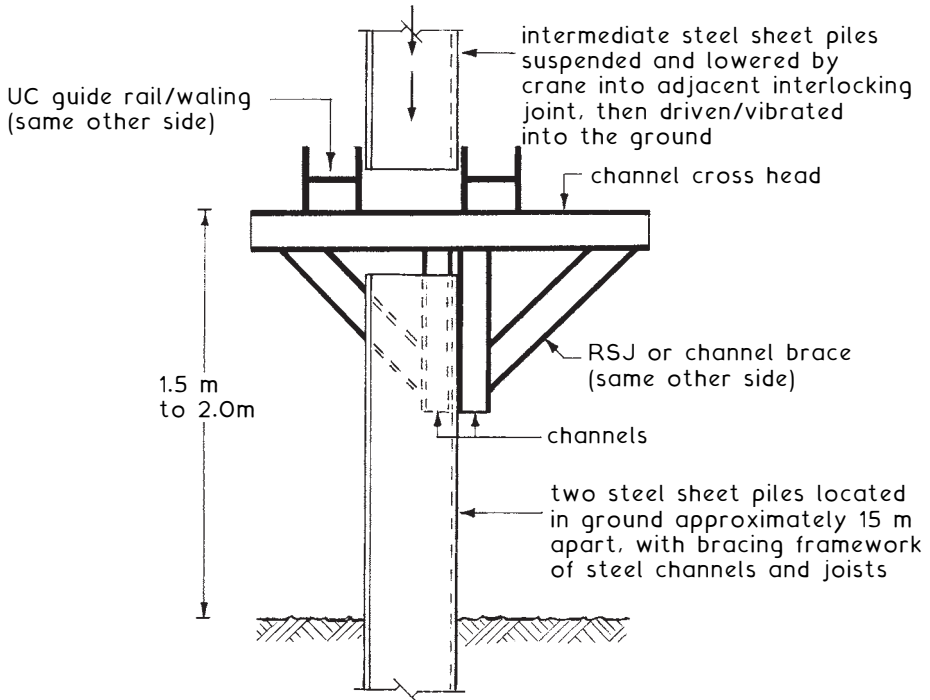

Steel trench sheeting is available in various profiles, including the following ~

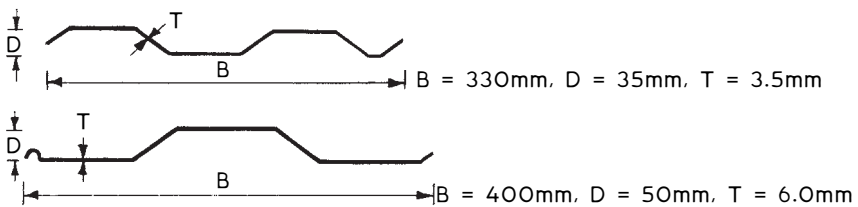

# Steel Sheet Piling

Applications ~

- Cofferdams
- Ground water control/diversion
- Barrier for ground water treatment systems
- Retaining walls
- Containment walls
- Flood protection
- Coastal protection, bulkheads and sea walls
- Tunnelling, cut and cover
- River weir walls
- Slope stabilisation
- Baffle walls

Compound Profiles ~

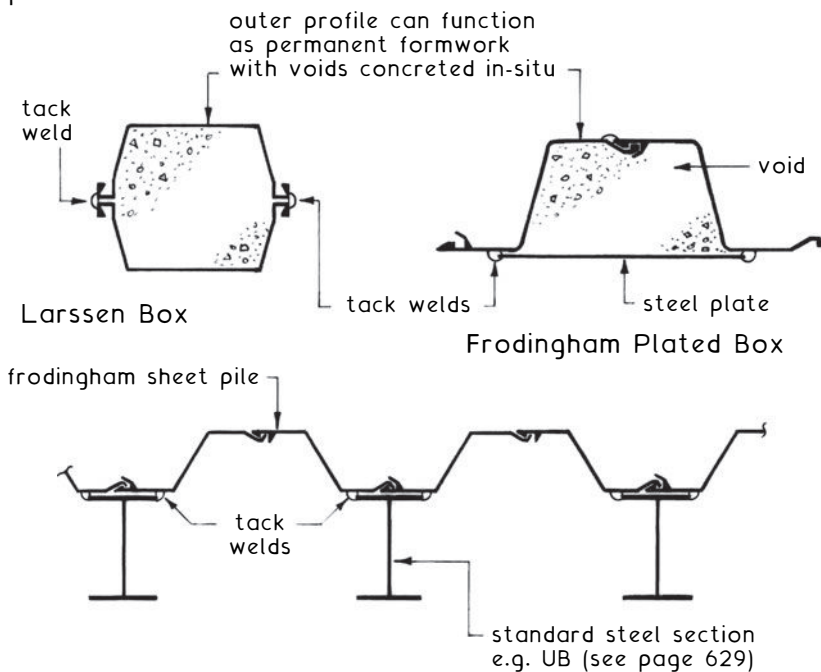

Note: Tack welding is jointing adjacent pieces of steel discontinuously.

Ref. BS EN 12063: Execution of special geotechnical work. Sheet pile walls.

Caissons ~ these are box-like structures which are similar in concept to cofferdams but they usually form an integral part of the finished structure. They can be economically constructed and installed in water or soil where the depth exceeds 18.000. There are four basic types of caisson, namely:

1. Box Caissons
  2. Open Caissons
  3. Monolithic Caissons
  4. Pneumatic Caissons - used in water - see next page.
- } usually of precast concrete and used in water being towed or floated into position and sunk - land caissons are of the open type and constructed in-situ.

Typical Caissons Details ~

precast concrete caisson sunk by flooding or adding weight

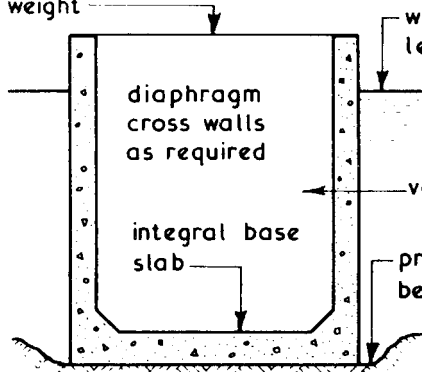

void filled with in-situ concrete after installation

**BOX CAISSON**

in-situ or precast concrete suspended cover slab

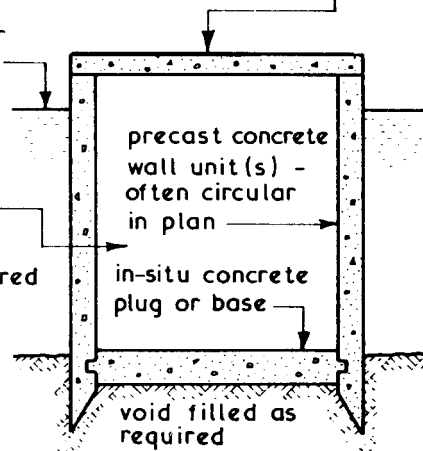

**OPEN CAISSON**

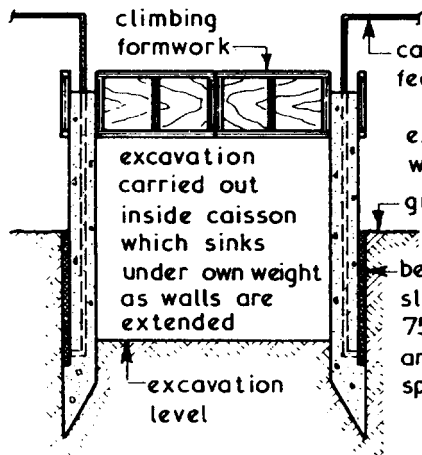

**LAND CAISSON**

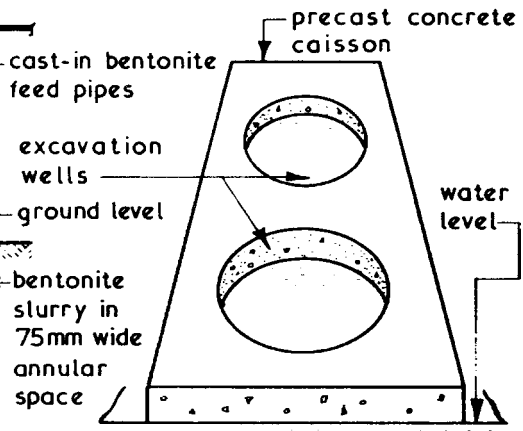

**MONOLITHIC CAISSON**

# Caissons

Pneumatic Caissons ~ these are sometimes called compressed air caissons and are similar in concept to open caissons. They can be used in difficult subsoil conditions below water level and have a pressurised lower working chamber to provide a safe, dry working area. Pneumatic caissons can be made of concrete whereby they sink under their own weight or they can be constructed from steel with hollow walls which can be filled with water to act as ballast. These caissons are usually designed to form part of the finished structure.

## Typical Pneumatic Caisson Details ~

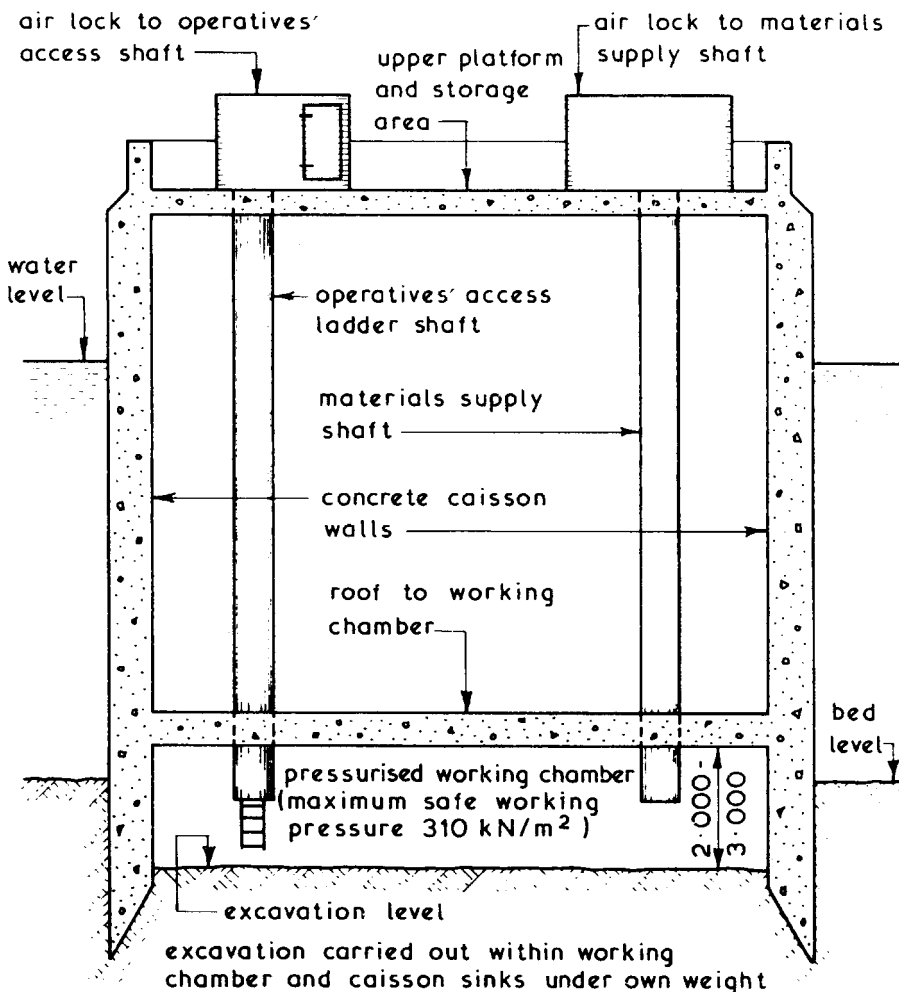

When required depth is reached a concrete slab or plug is cast over the formation level and chamber sealed with mass concrete

## Culverts – Principles and Types

Culvert ~ construction for subways and underground passageways. Often used below elevated roads and railways as access for pedestrians, animals (badger crossings), sewers, tidal outfalls and as voids for the general location of pipes and cables.

Types ~ box, conduit or pipe, manufactured from reinforced concrete for placing in large excavations before backfilling; a technique known as cut and cover. Excavations may require temporary support from sheet steel piling. Ground dewatering may also be necessary.

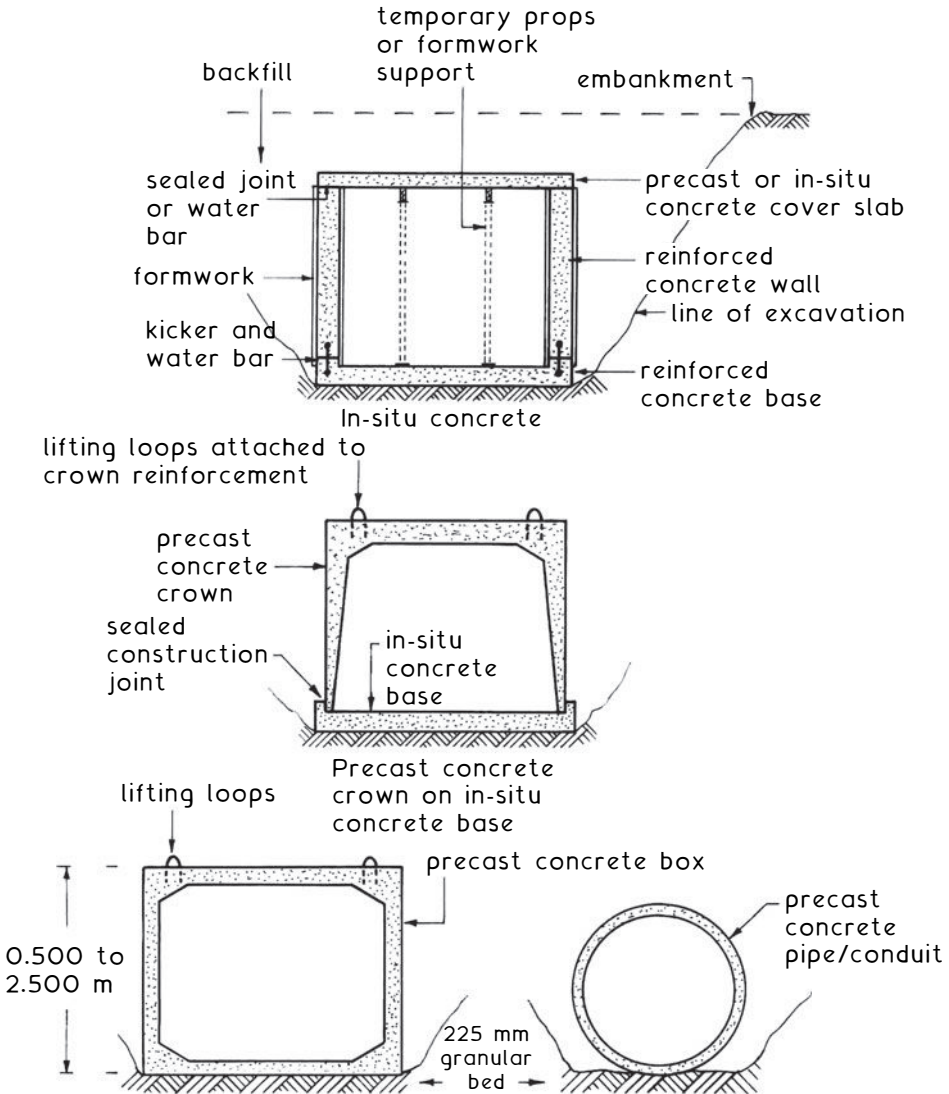

Precast concrete sections in standard lengths of 1.000, 1.500 or 2.000 m and up to 4.000 m width or diameter



## Culverts – Application and installation

Principles of Procedure ~ after excavating to the appropriate depth, the base is levelled (slightly inclined for drainage) and finished with well compacted selected stone granules. Granular material is used to consolidate the soil and to ease movement of the precast concrete sections as they are pulled into place. After crane lowering several sections into approximate locations, the first is positioned, levelled and restrained for attachment of anchor tension units. The remaining sections are pulled into place as shown below. Spigot and socket joints are sealed with a synthetic rubber gasket or mastic sealant. Thereafter, further sections are added, similarly positioned and jointed. Subsequently, the complete installation is backfilled for ground reinstatement.

### Assembly of precast concrete sections

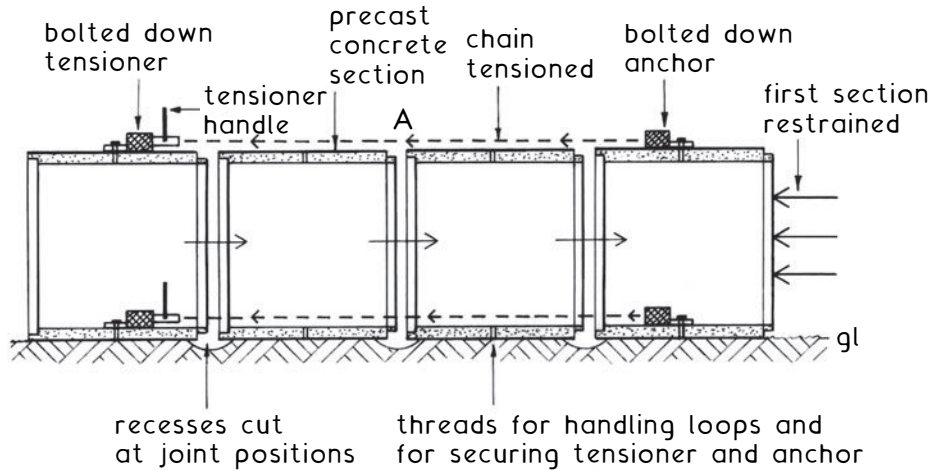

### Joint detail at A

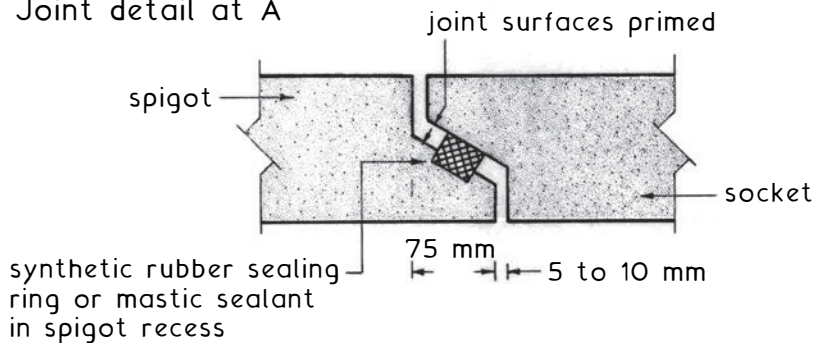

Underpinning ~ the main objective of most underpinning work is to transfer the load carried by a foundation from its existing bearing level to a new level at a lower depth. Underpinning techniques can also be used to replace an existing weak foundation. An underpinning operation may be necessary for one or more of the following reasons:

1. Uneven Settlement - this could be caused by uneven loading of the building, unequal resistance of the soil action of tree roots or cohesive soil settlement.
2. Increase in Loading - this could be due to the addition of an extra storey or an increase in imposed loadings such as that which may occur with a change of use.
3. Lowering of Adjacent Ground - usually required when constructing a basement adjacent to existing foundations.

General Precautions ~ before any form of underpinning work is commenced the following precautions should be taken:

1. Notify adjoining owners of proposed works giving full details and temporary shoring or tying.
2. Carry out a detailed survey of the site, the building to be underpinned and of any other adjoining or adjacent building or structures. A careful record of any defects found should be made and where possible agreed with the adjoining owner(s) before being lodged in a safe place.
3. Indicators or 'tell-tales' should be fixed over existing cracks so that any subsequent movements can be noted and monitored.
4. If settlement is the reason for the underpinning works a thorough investigation should be carried out to establish the cause and any necessary remedial work put in hand before any underpinning works are started.
5. Before any underpinning work is started the loads on the building to be underpinned should be reduced as much as possible by removing the imposed loads from the floors and installing any props and/or shoring which is required.
6. Any services which are in the vicinity of the proposed underpinning works should be identified, traced, carefully exposed, supported and protected as necessary.

## Underpinning

Underpinning to Walls ~ to prevent fracture, damage or settlement of the wall(s) being underpinned the work should always be carried out in short lengths called legs or bays. The length of these bays will depend upon the following factors:

1. Total length of wall to be underpinned.
2. Wall loading.
3. General state of repair and stability of wall and foundation to be underpinned.
4. Nature of subsoil beneath existing foundation.
5. Estimated spanning ability of existing foundation.

Generally suitable bay lengths are:

1.000 to 1.500 for mass concrete strip foundations supporting walls of traditional construction.

1.500 to 3.000 for reinforced concrete strip foundations supporting walls of moderate loading.

In all cases the total sum of the unsupported lengths of wall should not exceed 25% of the total wall length.

The sequence of bays should be arranged so that working in adjoining bays is avoided until one leg of underpinning has been completed, pinned and cured sufficiently to support the wall above.

### Typical Underpinning Schedule ~

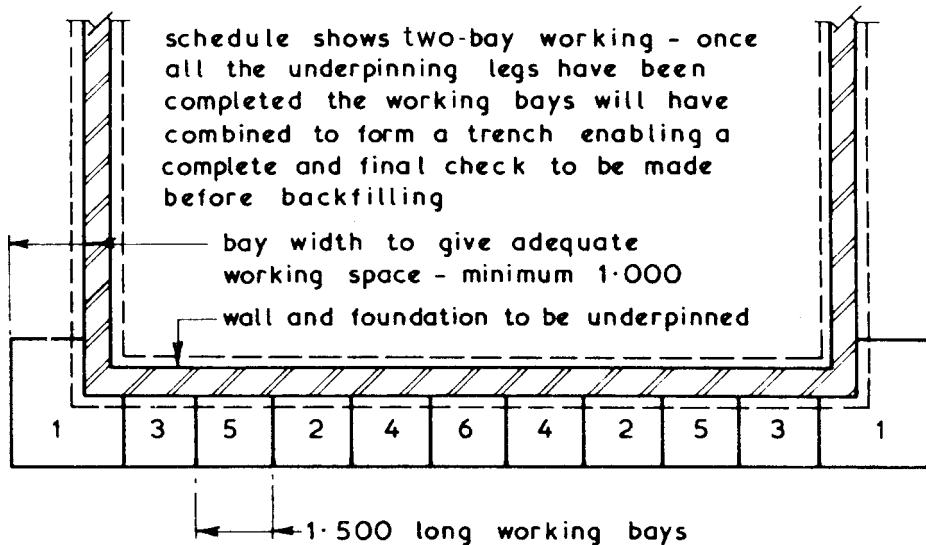

Typical Traditional Underpinning Details ~

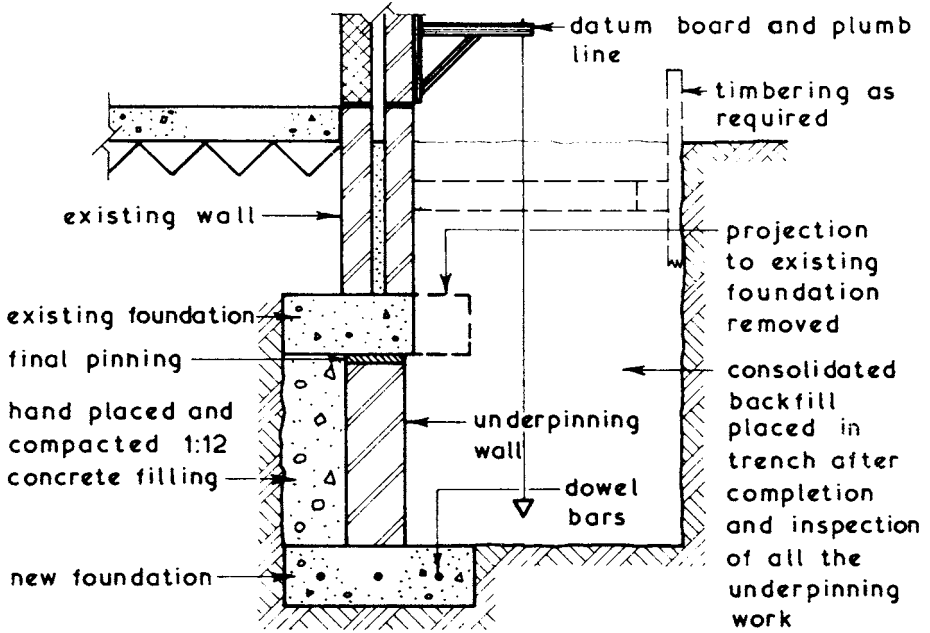

UNDERPINNING BAY ~ TYPICAL SECTION

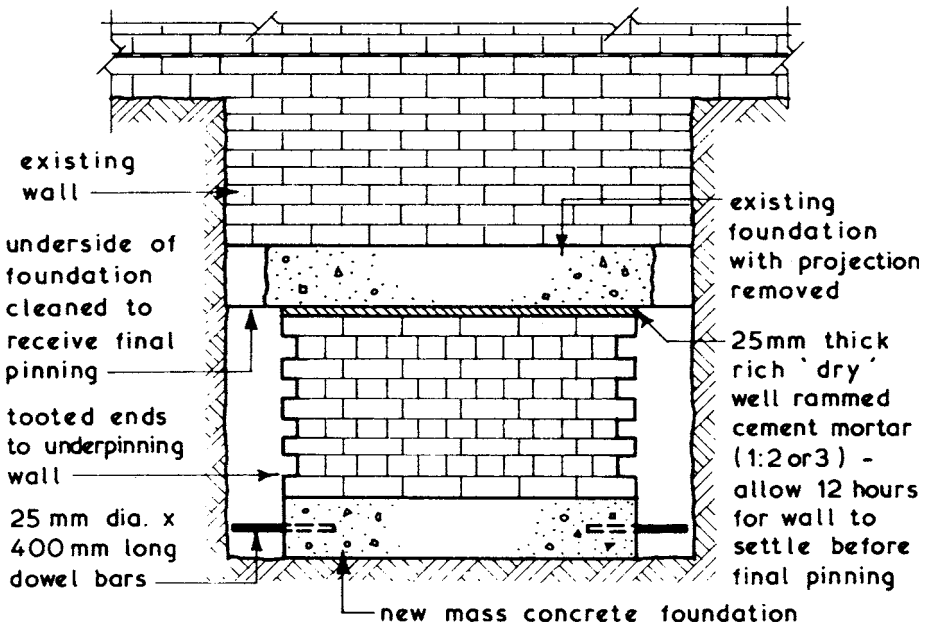

UNDERPINNING BAY ~ TYPICAL ELEVATION

# Underpinning

Jack Pile Underpinning ~ this method can be used when the depth of a suitable bearing capacity subsoil is too deep to make traditional underpinning uneconomic. Jack pile underpinning is quiet, vibration free and flexible since the pile depth can be adjusted to suit subsoil conditions encountered. The existing foundations must be in a good condition since they will have to span over the heads of the pile caps which are cast onto the jack pile heads after the hydraulic jacks have been removed.

## Typical Details ~

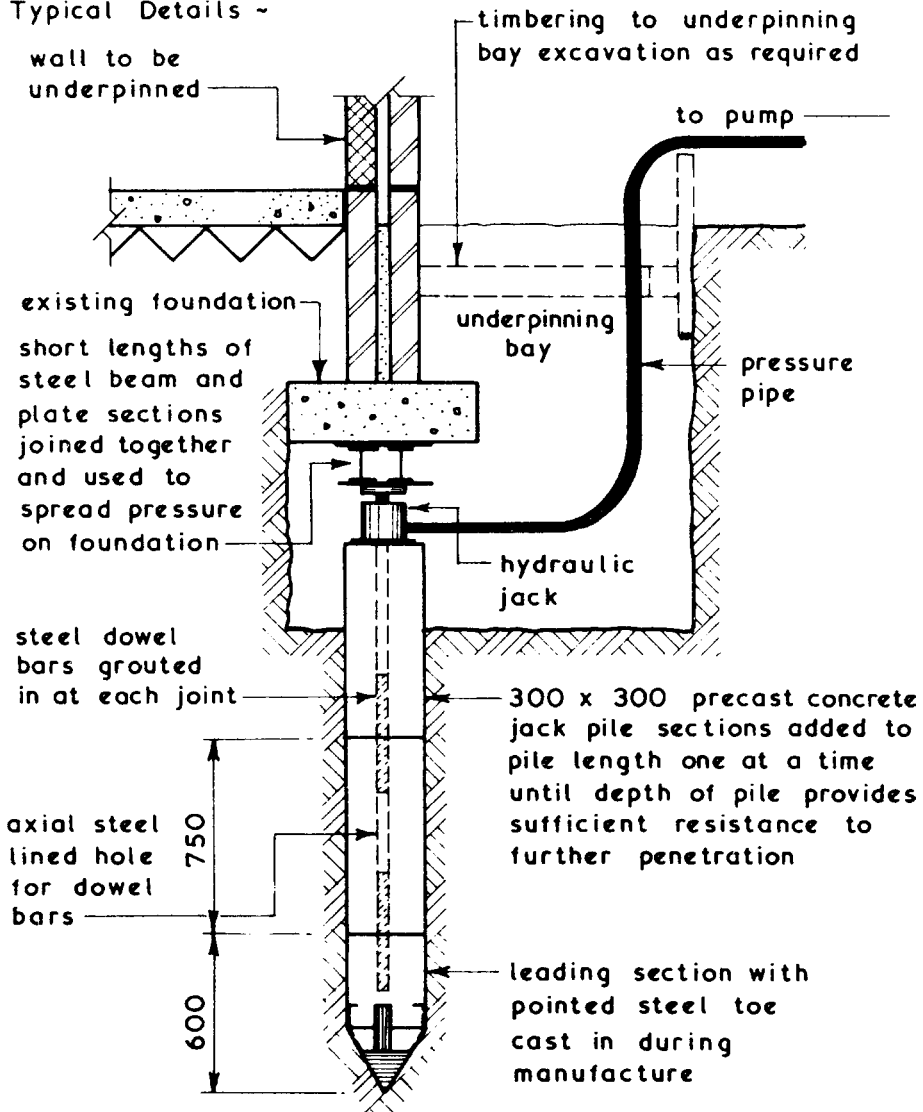

Needle and Pile Underpinning ~ this method of underpinning can be used where the condition of the existing foundation is unsuitable for traditional or jack pile underpinning techniques. The brickwork above the existing foundation must be in a sound condition since this method relies on the 'arching effect' of the brick bonding to transmit the wall loads onto the needles and ultimately to the piles. The piles used with this method are usually small diameter bored piles - see page 268.

#### Typical Details ~

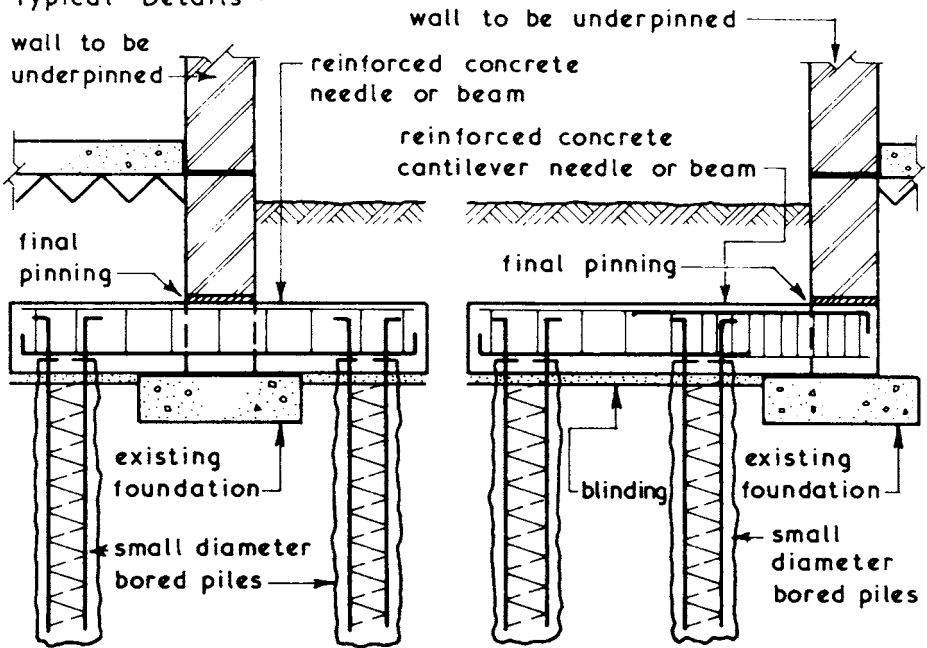

#### Alternative Layouts ~

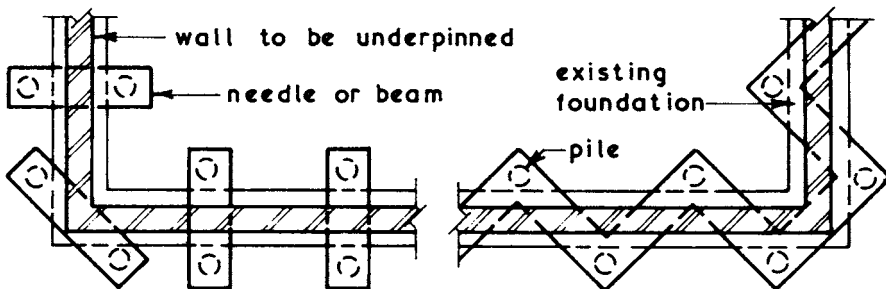

TRADITIONAL - simple

ZIG ZAG - uses less piles

# Underpinning

'Pynford' Stool Method of Underpinning ~ this method can be used where the existing foundations are in a poor condition and it enables the wall to be underpinned in a continuous run without the need for needles or shoring. The reinforced concrete beam formed by this method may well be adequate to spread the load of the existing wall or it may be used in conjunction with other forms of underpinning such as traditional and jack pile.

## Typical Details ~

Stage 1 - holes formed in wall to receive steel or precast concrete stools

Stage 2 - stools inserted and pinned to soffit of brickwork over opening

Stage 3 - brickwork between pinned stools removed to leave wall supported on pinned stools

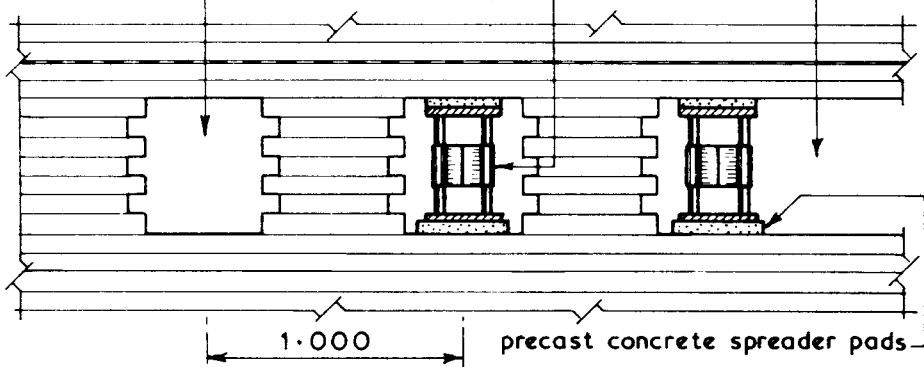

Stage 4 - reinforcement cast around pinned stools

Stage 5 - formwork fabricated and placed erected and beam cast

Stage 6 - formwork removed, beam allowed to cure before being pinned to underside of wall

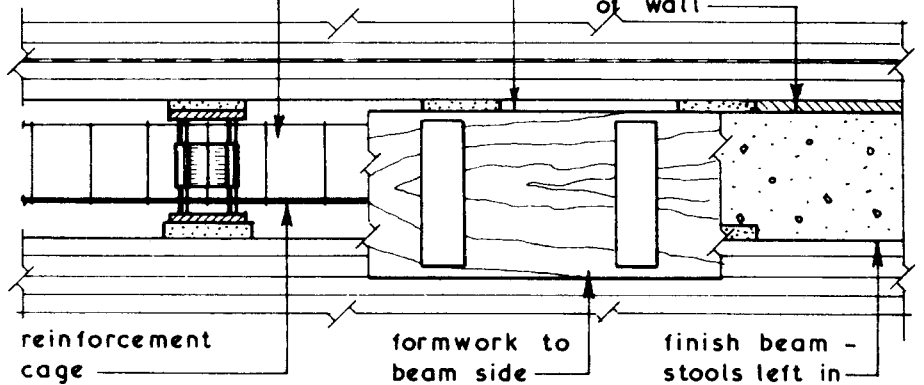

Root Pile or Angle Piling ~ this is a much simpler alternative to traditional underpinning techniques, applying modern concrete drilling equipment to achieve cost benefits through time saving. The process is also considerably less disruptive, as large volumes of excavation are avoided. Where sound bearing strata can be located within a few metres of the surface, wall stability is achieved through lined reinforced concrete piles installed in pairs, at opposing angles. The existing floor, wall and foundation are pre-drilled with air-flushed percussion auger, giving access for a steel lining to be driven through the low grade/clay subsoil until it impacts with firm strata. The lining is cut to terminate at the underside of the foundation and the void steel reinforced prior to concreting.

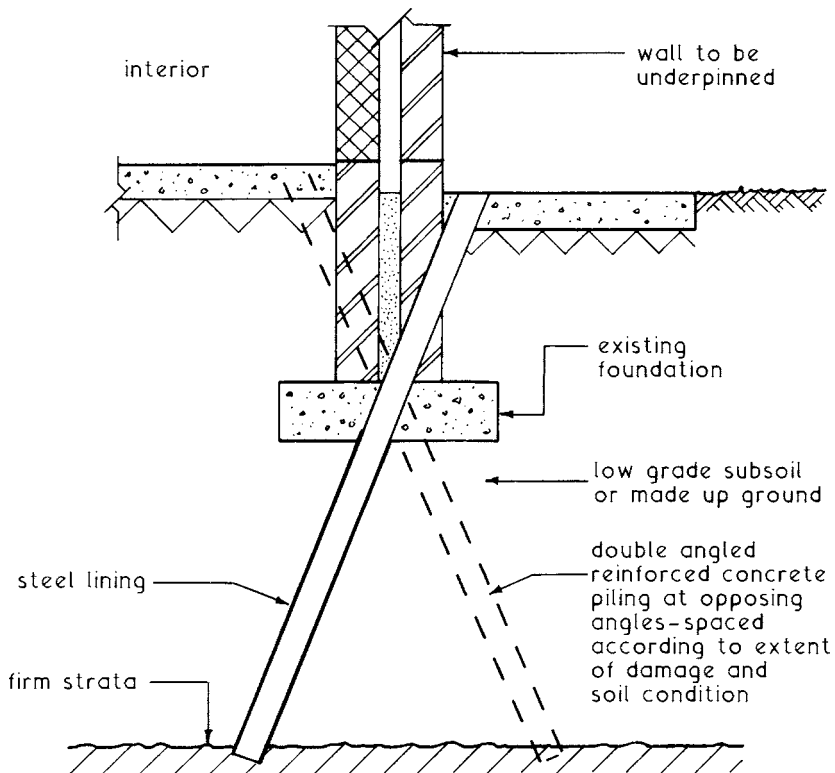

In many situations it is impractical to apply angle piling to both sides of a wall. Subject to subsoil conditions being adequate, it may be acceptable to apply remedial treatment from one side only. The piles will need to be relatively close spaced.



# Underpinning

Underpinning Columns ~ columns can be underpinned in the same manner as walls using traditional or jack pile methods after the columns have been relieved of their loadings. The beam loads can usually be transferred from the columns by means of dead shores and the actual load of the column can be transferred by means of a pair of beams acting against a collar attached to the base of the column shaft.

## Typical Details ~

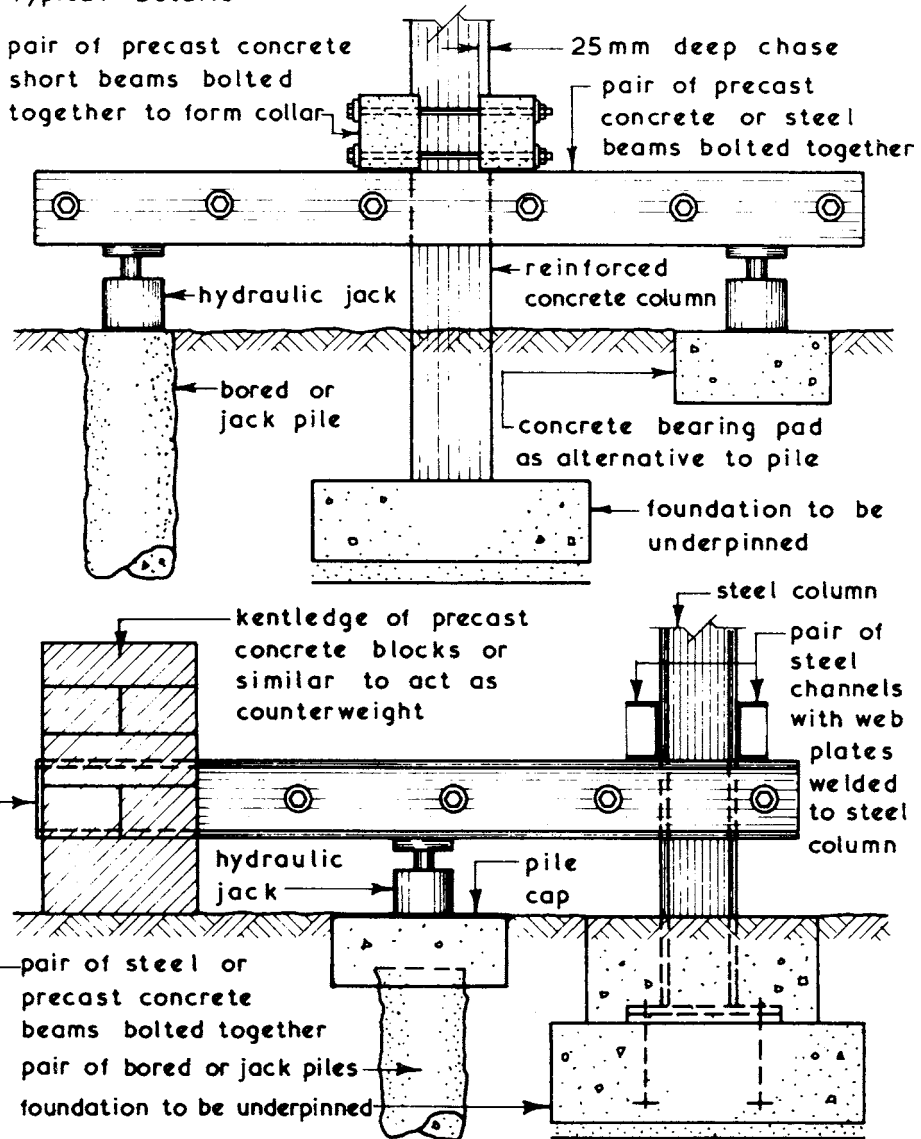

Classification of Water ~ water can be classified by its relative position to or within the ground thus -

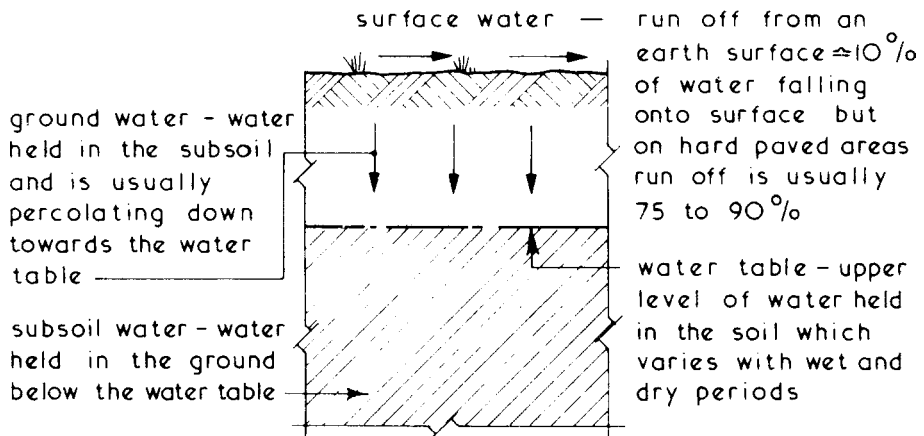

Problems of Water in the Subsoil:

1. A high water table could cause flooding during wet periods.
2. Subsoil water can cause problems during excavation works by its natural tendency to flow into the voids created by the excavation activities.
3. It can cause an unacceptable humidity level around finished buildings and structures.

Control of Ground Water ~ this can take one of two forms which are usually referred to as temporary and permanent exclusion -

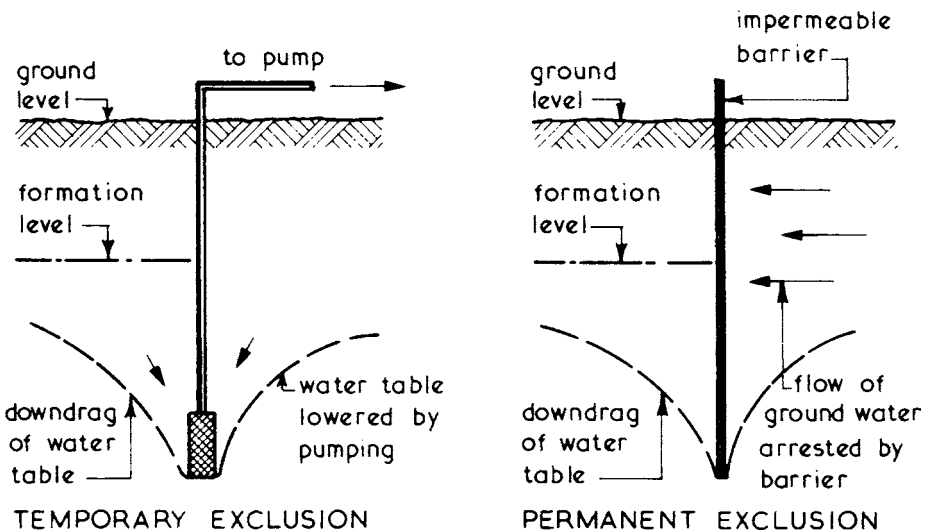

# Ground Water Control – Temporary Exclusion

Permanent Exclusion ~ this can be defined as the insertion of an impermeable barrier to stop the flow of water within the ground.

Temporary Exclusion ~ this can be defined as the lowering of the water table and within the economic depth range of 1:500 can be achieved by subsoil drainage methods; for deeper treatment a pump or pumps are usually involved.

Simple Sump Pumping ~ suitable for trench work and/or where small volumes of water are involved.

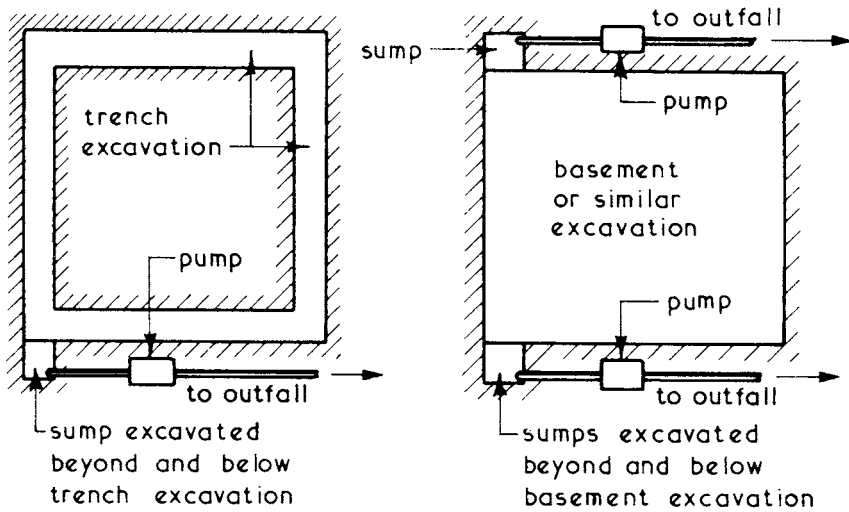

## Sizing Pumps ~

allow for friction loss due to fittings in terms of pipe length - added to actual pipe length

allowances for friction and head loss available from manufacturers' charts or tables  
 calculate or estimate water flow

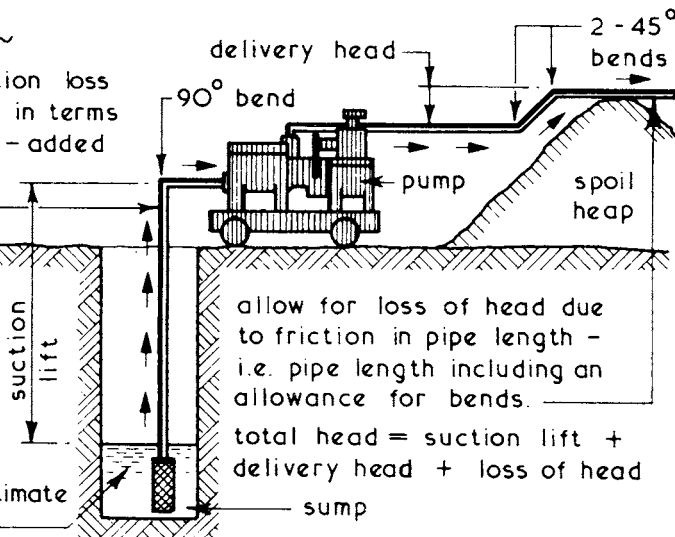

allow for loss of head due to friction in pipe length - i.e. pipe length including an allowance for bends.

total head = suction lift + delivery head + loss of head

Jetted Sumps ~ this method achieves the same objectives as the simple sump methods of dewatering (previous page) but it will prevent the soil movement associated with this and other open sump methods. A borehole is formed in the subsoil by jetting a metal tube into the ground by means of pressurised water, to a depth within the maximum suction lift of the extract pump. The metal tube is withdrawn to leave a void for placing a disposable wellpoint and plastic suction pipe. The area surrounding the pipe is filled with coarse sand to function as a filtering media.

Typical Example ~

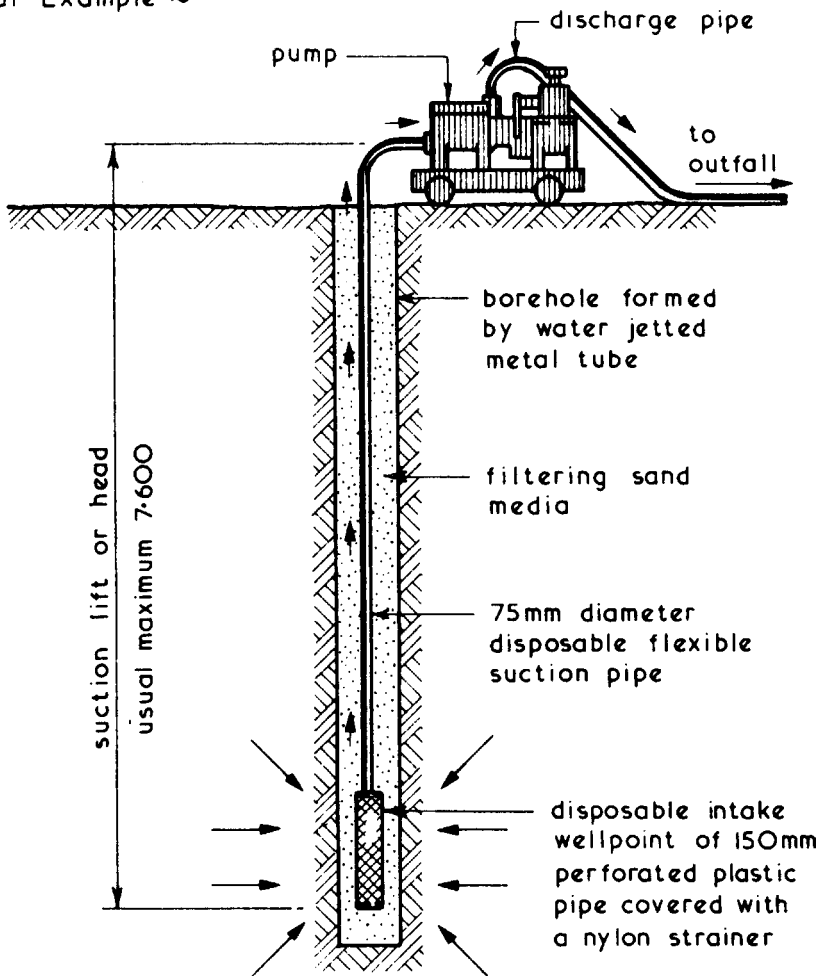

# Ground Water Control – Temporary Exclusion

Wellpoint Systems ~ method of lowering the water table to a position below the formation level to give a dry working area. The basic principle is to jet into the subsoil a series of wellpoints which are connected to a common header pipe which is connected to a vacuum pump. Wellpoint systems are suitable for most subsoils and can encircle an excavation or be laid progressively alongside as in the case of a trench excavation. If the proposed formation level is below the suction lift capacity of the pump a multi-stage system can be employed – see next page.

## Typical Details ~

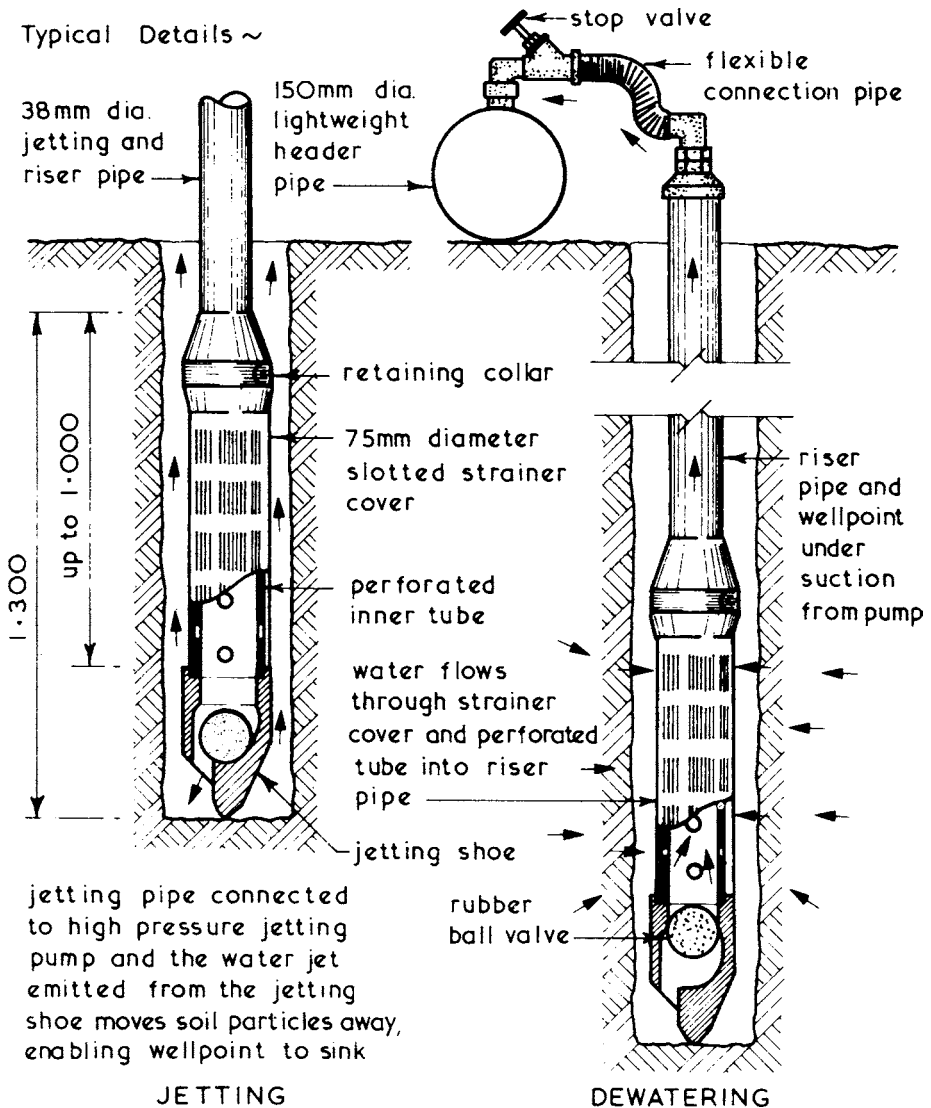

Typical Wellpoint Progress Line Installation Details ~

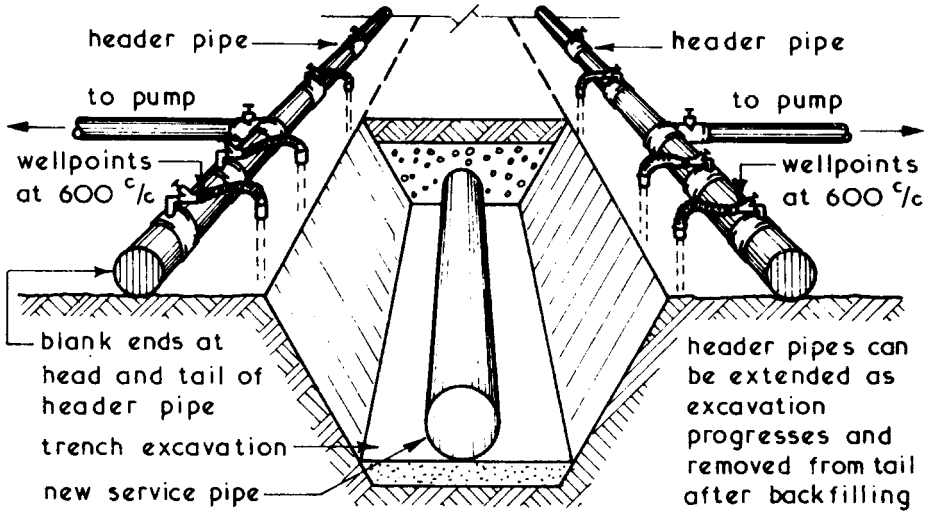

Typical Multi-stage Wellpoint Installation Details ~

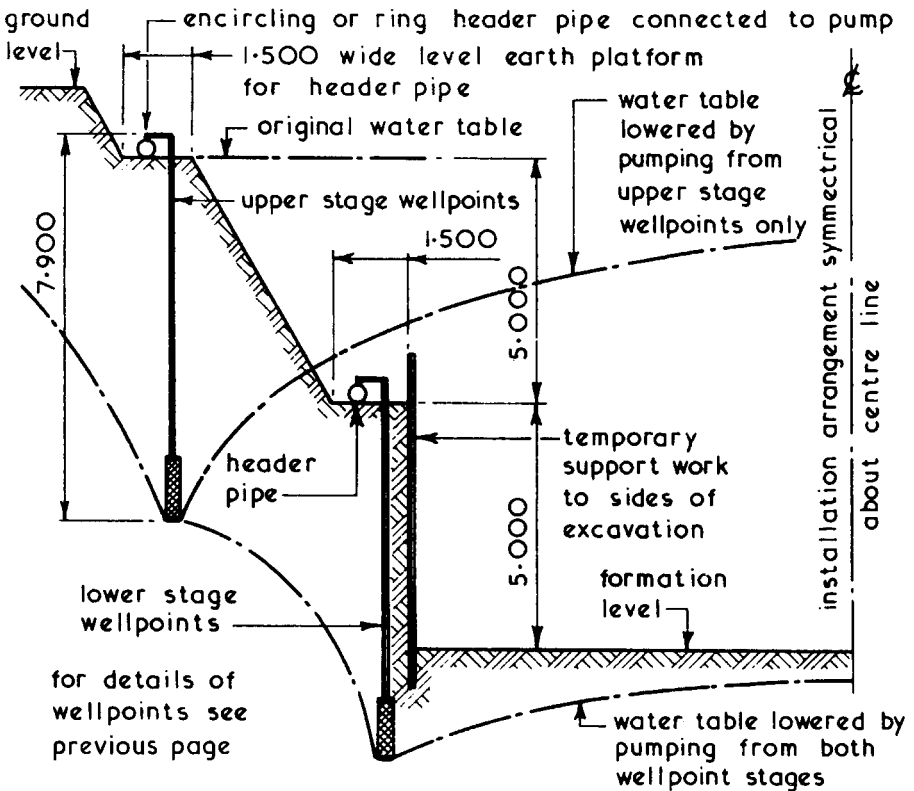

# Ground Water Control – Permanent Exclusion

Thin Grouted Membranes ~ these are permanent curtain or cut-off non-structural walls or barriers inserted in the ground to enclose the proposed excavation area. They are suitable for silts and sands and can be installed rapidly but they must be adequately supported by earth on both sides. The only limitation is the depth to which the formers can be driven and extracted.

Typical Details ~

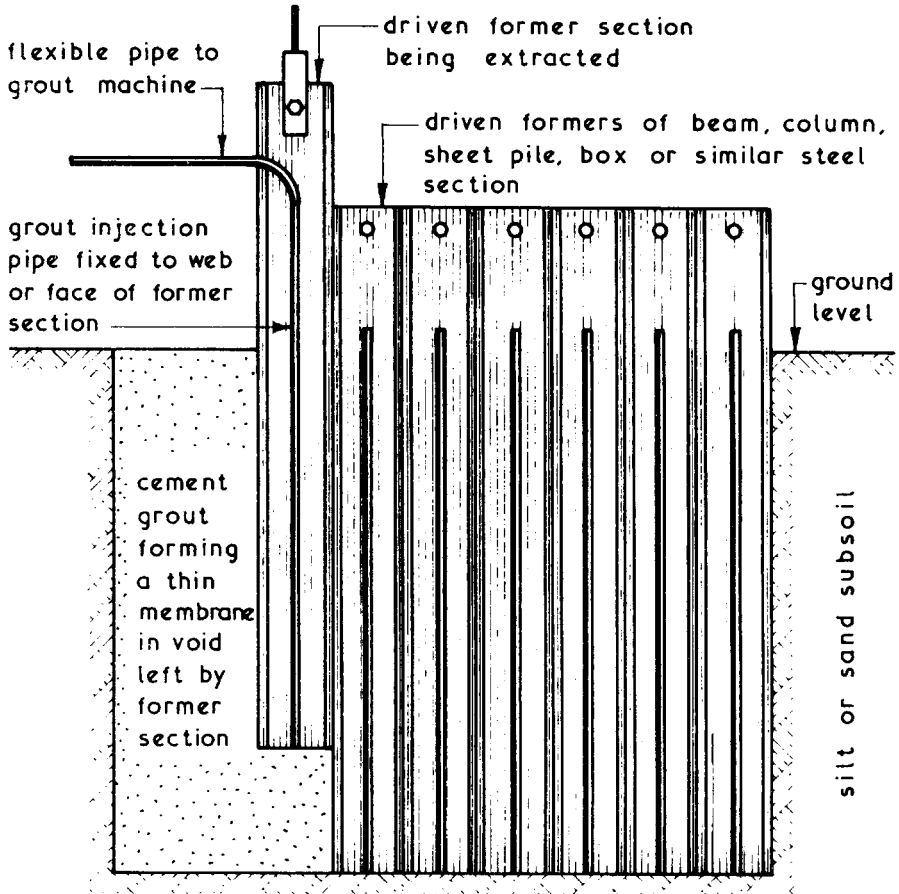

ELEVATION

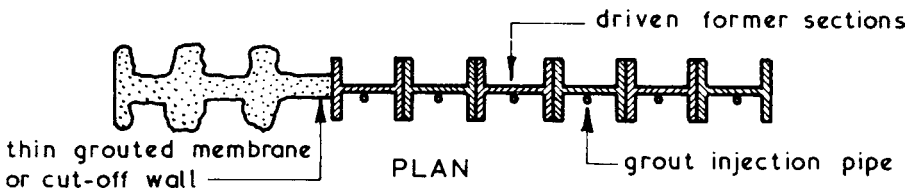

PLAN

Contiguous or Secant Piling ~ this forms a permanent structural wall of interlocking bored piles. Alternate piles are bored and cast by traditional methods and before the concrete has fully hardened the interlocking piles are bored using a toothed flight auger. This system is suitable for most types of subsoil and has the main advantages of being economical on small and confined sites; capable of being formed close to existing foundations and can be installed with the minimum of vibration and noise. Ensuring a complete interlock of all piles over the entire length may be difficult to achieve in practice; therefore the exposed face of the piles is usually covered with a mesh or similar fabric and face with rendering or sprayed concrete. Alternatively a reinforced concrete wall could be cast in front of the contiguous piling. This method of ground water control is suitable for structures such as basements, road underpasses and underground car parks.

Typical Details -

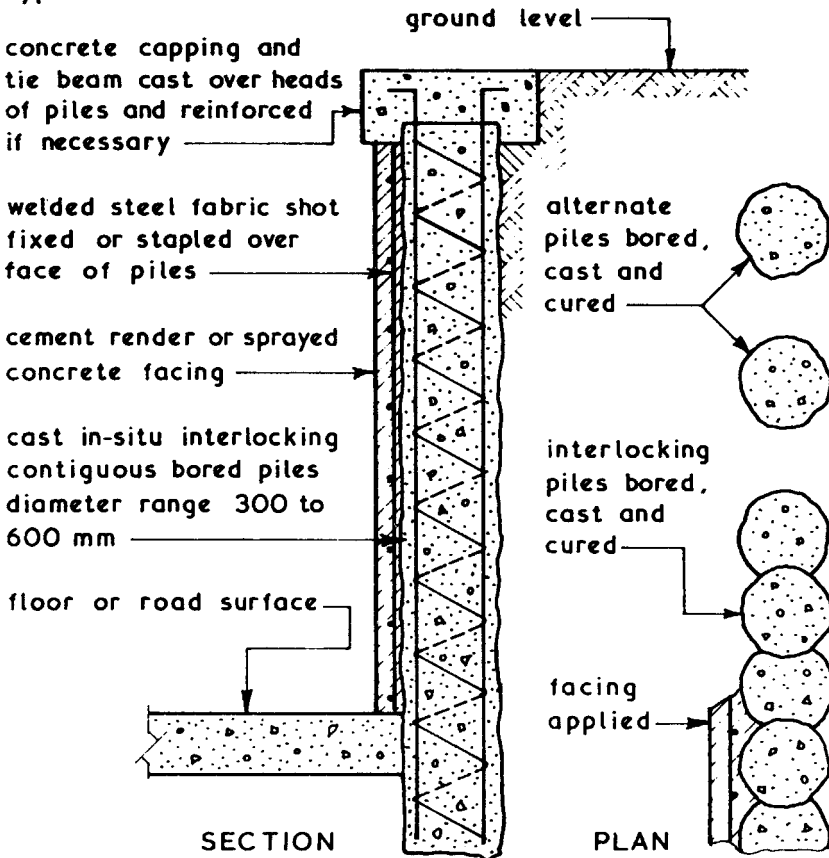



## Ground Water Control – Permanent Exclusion

Diaphragm Walls ~ these are structural concrete walls which can be cast in-situ (usually by the bentonite slurry method) or constructed using precast concrete components (see next page). They are suitable for most subsoils and their installation generates only a small amount of vibration and noise, making them suitable for works close to existing buildings. The high cost of these walls makes them uneconomic unless they can be incorporated into the finished structure. Diaphragm walls are suitable for basements, underground car parks and similar structures.

Typical Cast In-situ Concrete Diaphragm Wall Details ~

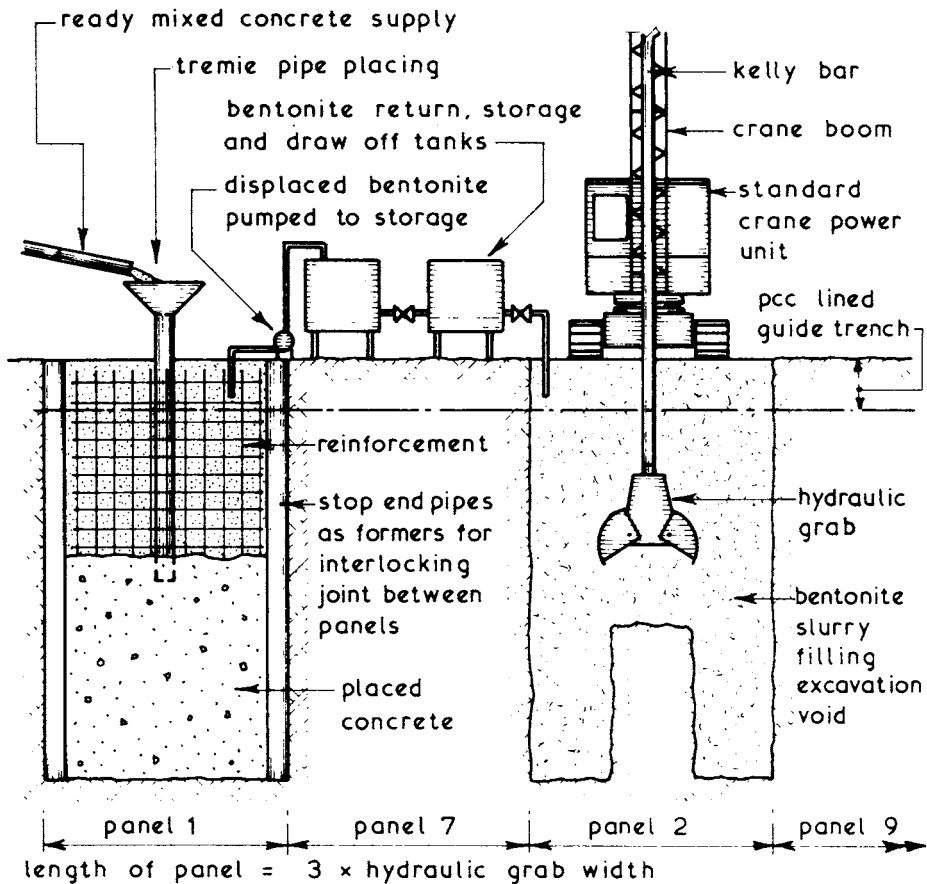

NB. Bentonite is a controlled mixture of fullers earth and water which produces a mud or slurry which has thixotropic properties and exerts a pressure in excess of earth+hydrostatic pressure present on sides of excavation.

Precast Concrete Diaphragm Walls ~ these walls have the same applications as their in-situ counterparts and have the advantages of factory-produced components but lack the design flexibility of cast in-situ walls. The panel or post and panel units are installed in a trench filled with a special mixture of bentonite and cement with a retarder to control the setting time. This mixture ensures that the joints between the wall components are effectively sealed. To provide stability the panels or posts are tied to the retained earth with ground anchors.

Typical Precast Concrete Diaphragm Wall Details ~

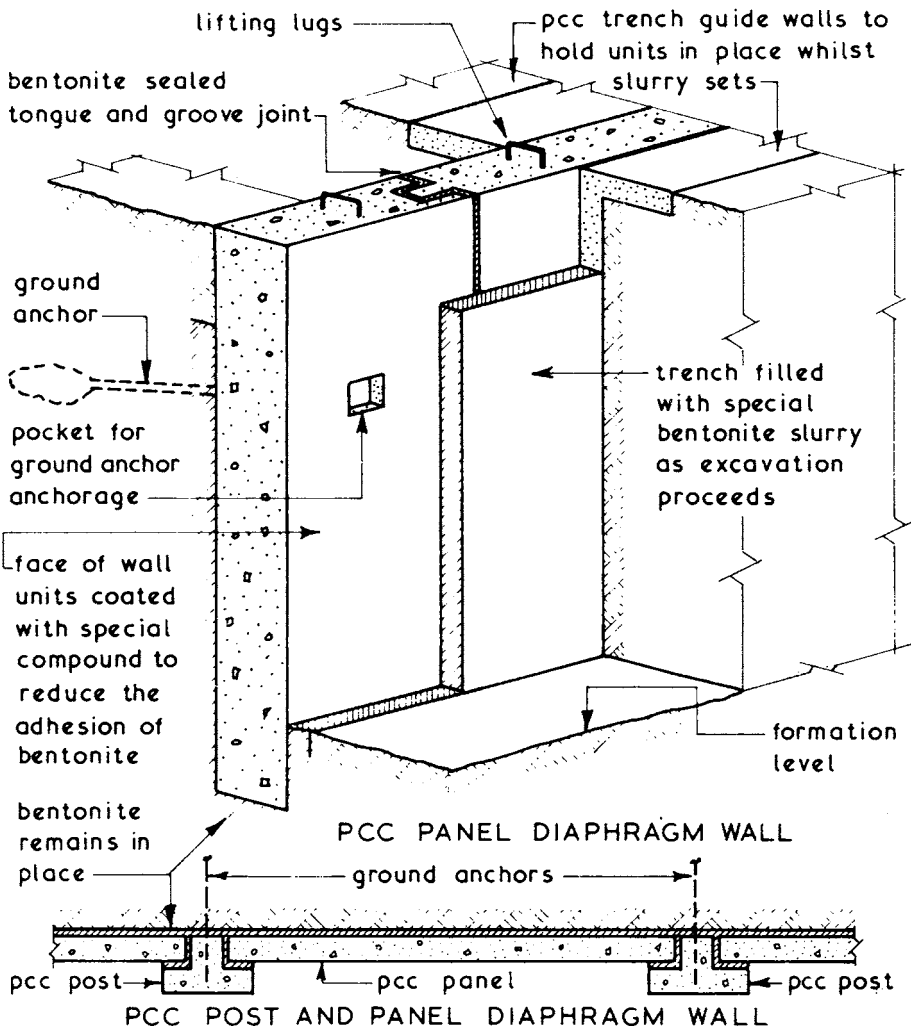

## Ground Water Control – Permanent Exclusion

Grouting Methods ~ these techniques are used to form a curtain or cut off wall in high permeability soils where pumping methods could be uneconomic. The curtain walls formed by grouting methods are non-structural; therefore adequate earth support will be required and in some cases this will be a distance of at least 4-000 from the face of the proposed excavation. Grout mixtures are injected into the soil by pumping the grout at high pressure through special injection pipes inserted in the ground. The pattern and spacing of the injection pipes will depend on the grout type and soil conditions.

Grout Types ~

1. Cement Grouts - mixture of neat cement and water cement sand up to 1:4 or PFA (pulverised fuel ash) cement to a 1:1 ratio. Suitable for coarse-grained soils and fissured and jointed rock strata.
2. Chemical Grouts - one shot (premixed) or two shot (first chemical is injected followed immediately by second chemical resulting in an immediate reaction) methods can be employed to form a permanent gel in the soil to reduce its permeability and at the same time increase the soil's strength. Suitable for medium to coarse sands and gravels.
3. Resin Grouts - these are similar in application to chemical grouts but have a low viscosity and can therefore penetrate into silty fine sands.

Typical Cement Grouting Details ~

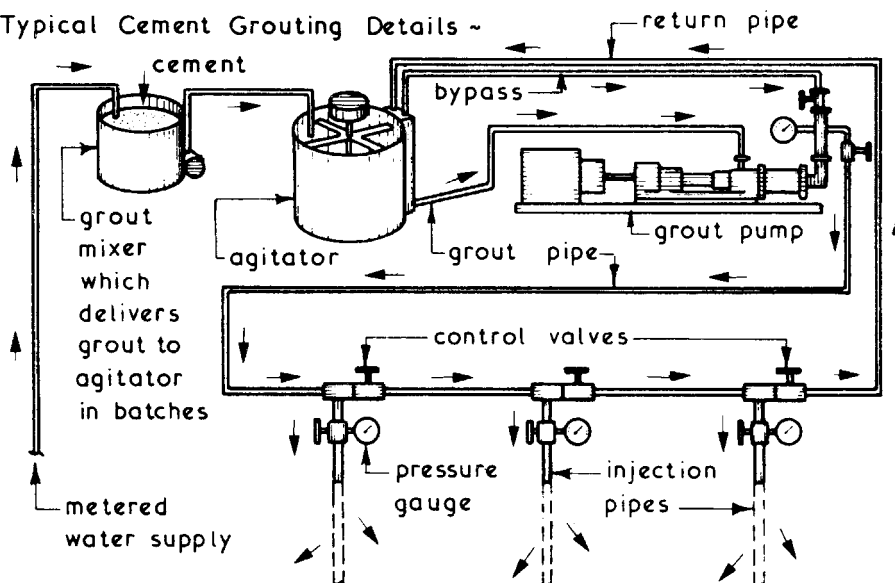

Ground Freezing Techniques ~ this method is suitable for all types of saturated soils and rock and for soils with a moisture content in excess of 8% of the voids. The basic principle is to insert into the ground a series of freezing tubes to form an ice wall thus creating an impermeable barrier. The treatment takes time to develop and the initial costs are high; therefore it is only suitable for large contracts of reasonable duration. The freezing tubes can be installed vertically for conventional excavations and horizontally for tunnelling works. The usual circulating brines employed are magnesium chloride and calcium chloride with a temperature of  $-15^{\circ}$  to  $-25^{\circ}\text{C}$  which would take 10 to 17 days to form an ice wall 1.000 thick. Liquid nitrogen could be used as the freezing medium to reduce the initial freezing period if the extra cost can be justified.

Typical Ground Freezing Details ~

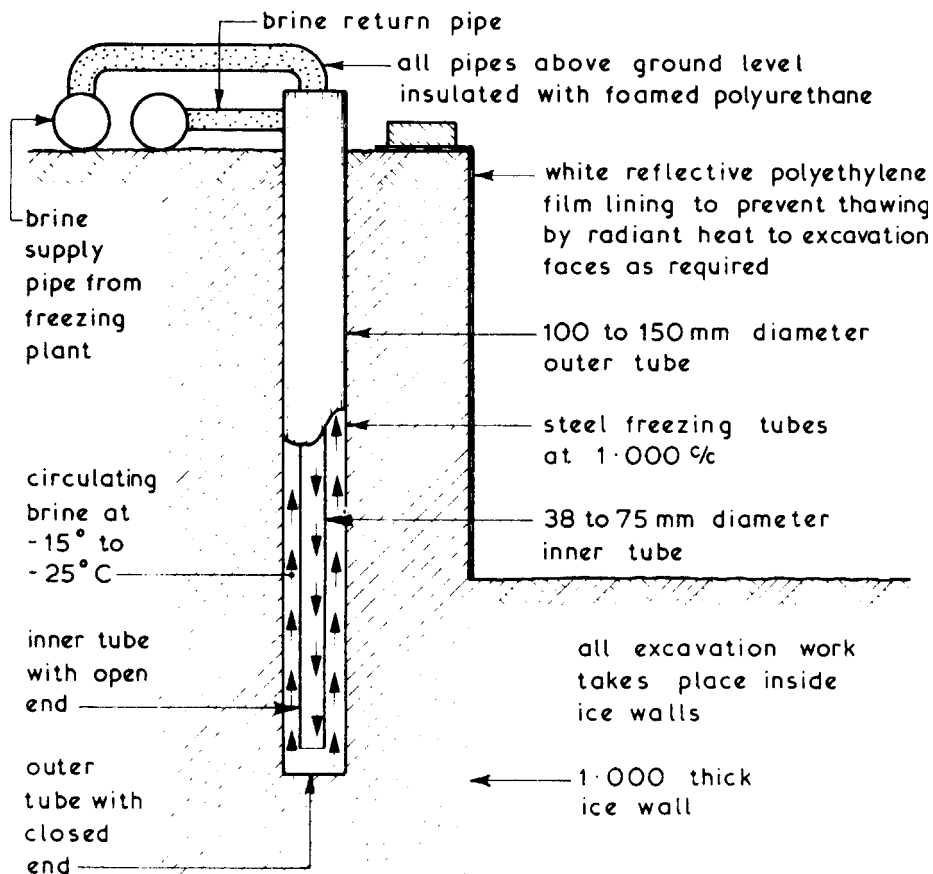

## Soil Stabilisation and Improvement

Soil Investigation ~ before a decision is made as to the type of foundation which should be used on any particular site a soil investigation should be carried out to establish existing ground conditions and soil properties. The methods which can be employed together with other sources of information such as local knowledge, ordnance survey and geological maps, mining records and aerial photography should be familiar to students at this level. If such an investigation reveals a naturally poor subsoil or extensive filling the designer has several options:

1. Not to Build - unless a new and suitable site can be found building is only possible if the poor ground is localised and the proposed foundations can be designed around these areas with the remainder of the structure bridging over these positions.
2. Remove and Replace - the poor ground can be excavated, removed and replaced by compacted fills. Using this method there is a risk of differential settlement and generally for depths over 4.000 it is uneconomic.
3. Surcharging - this involves preloading the poor ground with a surcharge of aggregate or similar material to speed up settlement and thereby improve the soil's bearing capacity. Generally this method is uneconomic due to the time delay before actual building operations can commence which can vary from a few weeks to two or more years.
4. Vibration - this is a method of strengthening ground by vibrating a granular soil into compacted stone columns either by using the natural coarse granular soil or by replacement - see pages 361 and 362.
5. Dynamic Compaction - this is a method of soil improvement which consists of dropping a heavy weight through a considerable vertical distance to compact the soil and thus improve its bearing capacity and is especially suitable for granular soils - see page 363.
6. Jet Grouting - this method of consolidating ground can be used in all types of subsoil and consists of lowering a monitor probe into a 150 mm diameter prebored guide hole. The probe has two jets the upper of which blasts water, concentrated by compressed air to force any loose material up the guide to ground level. The lower jet fills the void with a cement slurry which sets into a solid mass - see page 364.

Ground Vibration ~ the objective of this method is to strengthen the existing soil by rearranging and compacting coarse granular particles to form stone columns with the ground. This is carried out by means of a large poker vibrator which has an effective compacting radius of 1.500 to 2.700. On large sites the vibrator is inserted on a regular triangulated grid pattern with centres ranging from 1.500 to 3.000. In coarse-grained soils extra coarse aggregate is tipped into the insertion positions to make up levels as required whereas in clay and other fine particle soils the vibrator is surged up and down enabling the water jetting action to remove the surrounding soft material thus forming a borehole which is backfilled with a coarse granular material compacted in-situ by the vibrator. The backfill material is usually of 20 to 70 mm size of uniform grading within the chosen range. Ground vibration is not a piling system but a means of strengthening ground to increase the bearing capacity within a range of 200 to 500 kN/m<sup>2</sup>.

### Typical Details ~

lifting pulley

manifold section

follower section(s)

top jets to assist in removal

vibration isolator

vibrator section containing hydraulic motor with rotating eccentric

compacted stone column

### Typical Vibrator Data:

length - 5.000

weight - 2 tonnes

vibration - 30 to 60 hz.

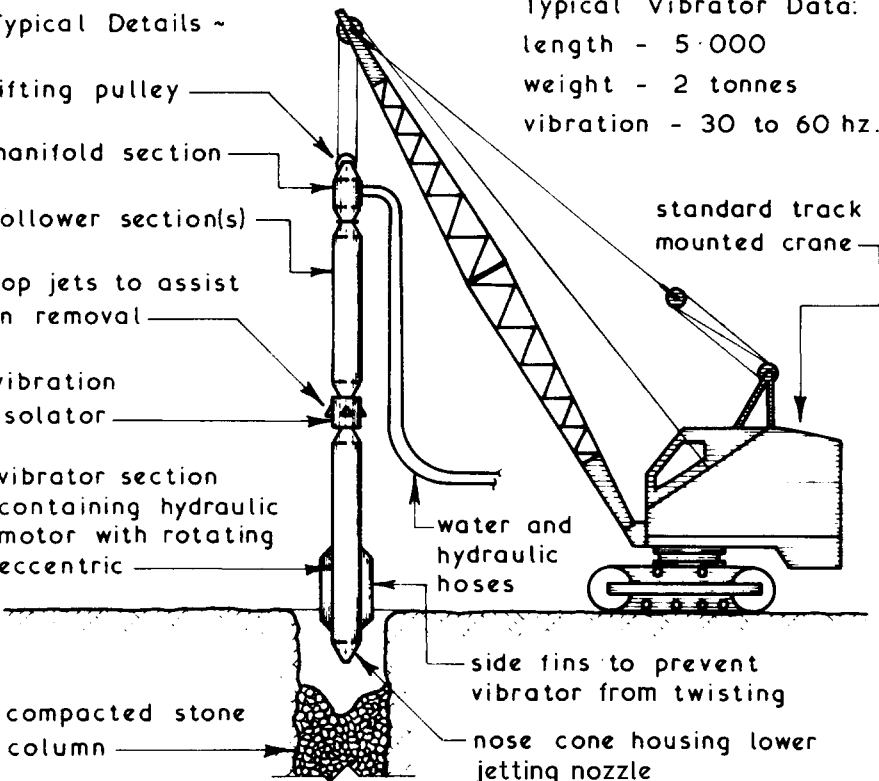

# Soil Stabilisation and Improvement

Sand Compaction - applied to non-cohesive subsoils where the granular particles are rearranged into a denser condition by poker vibration.

The crane-suspended vibrating poker is water-jetted into the ground using a combination of self-weight and water displacement of the finer soil particles to penetrate the ground. Under this pressure, the soil granules compact to increase in density as the poker descends. At the appropriate depth, which may be determined by building load calculations or the practical limit of plant (generally 30m max.), jetting ceases and fine aggregates or sand are infilled around the poker. The poker is then gradually withdrawn compacting the granular fill in the process. Compaction continues until sand fill reaches ground level. Spacing of compaction boreholes is relatively close to ensure continuity and an integral ground condition.

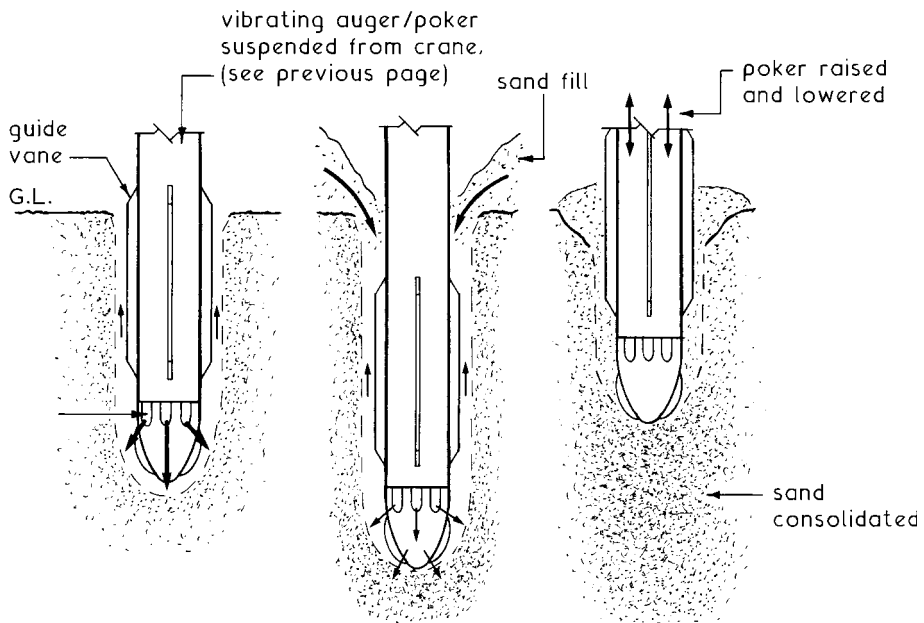

1. Vibrating poker penetrates ground under full water jet pressure.

2. At design depth, water pressure is reduced and sand fill introduced and compacted.

3. With resistance to compaction, poker is raised and lowered to consolidate further sand.

Sand compaction procedure

Dynamic Compaction ~ this method of ground improvement consists of dropping a heavy weight from a considerable height and is particularly effective in granular soils. Where water is present in the subsoil, trenches should be excavated to allow the water to escape and not collect in the craters formed by the dropped weight. The drop pattern, size of weight and height of drop are selected to suit each individual site but generally three or four drops are made in each position forming a crater up to 2.500 deep and 5.000 in diameter. Vibration through the subsoil can be a problem with dynamic compaction operations; therefore the proximity and condition of nearby buildings must be considered together with the depth position and condition of existing services on site.

#### Typical Details ~

NB. Final ground level after compaction treatment and final levelling could be up to 1.500 lower than original ground level.

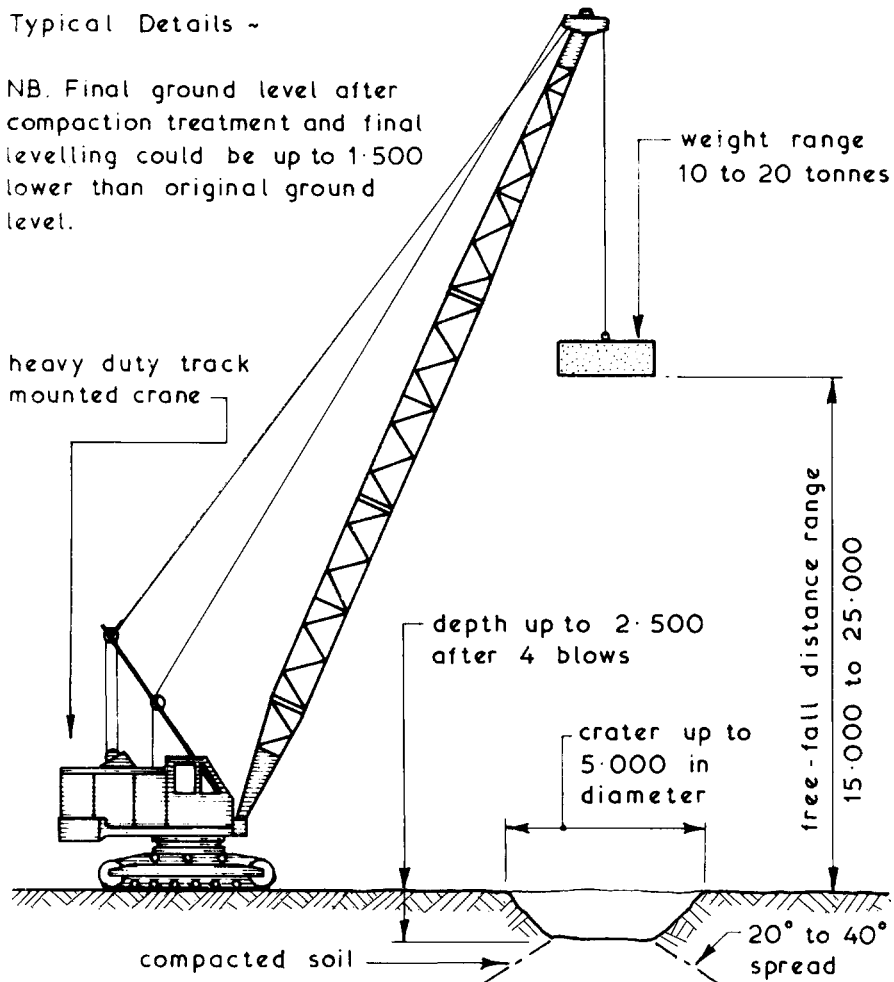



# Soil Stabilisation and Improvement

Jet Grouting ~ this is a means of consolidating ground by lowering a monitor probe into preformed boreholes. The probe is rotated and the sides of the borehole are subjected to a jet of pressurised water and air from a single outlet which enlarges and compacts the borehole sides. At the same time a cement grout is being introduced under pressure to fill the void being created. The water used by the probe and any combined earth is forced up to the surface in the form of a sludge. If the monitor probe is not rotated grouted panels can be formed. The spacing, depth and layout of the boreholes is subject to specialist design.

## Typical Details ~

crawler mounted power unit → motor - raises, lowers and rotates probe

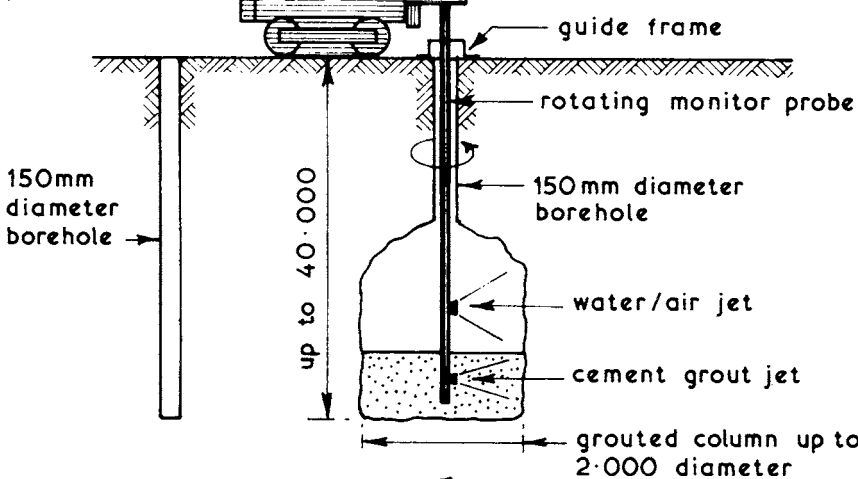

crawler mounted power unit → motor - raises and lowers probe

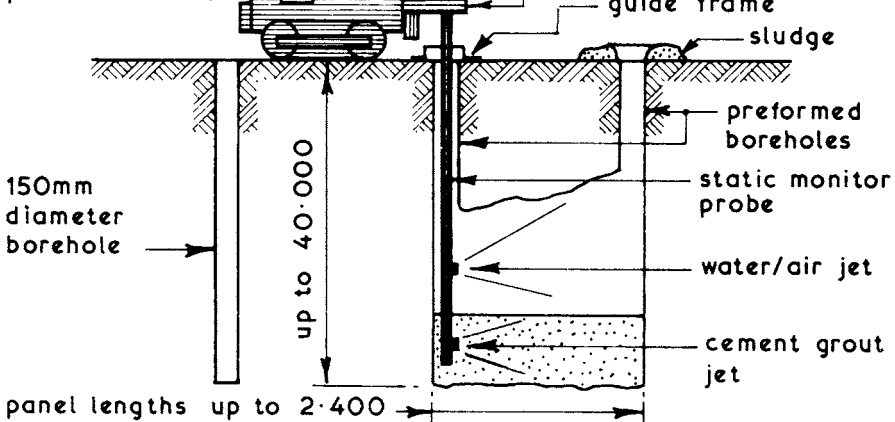

Green-field - land not previously built upon. Usually part of the 'green-belt' surrounding urban areas, designated inappropriate for development in order to preserve the countryside. Limited development for agricultural purposes only may be permitted on 'green-belt' land.

Brown-field - derelict land formerly a developed site and usually associated with previous construction of industrial buildings. The UK government has an objective to build 60% of new homes on these sites.

Site Survey - land previously used for industrial buildings could be contaminated with hazardous waste or pollutants. Therefore it is essential that a geo-technical survey is undertaken to determine whether contaminants are in the soil and ground water. Of particular concern are: acids, salts, heavy metals, cyanides and coal tars, in addition to organic materials which decompose to form the highly explosive gas methane. Analysis of the soil will determine a 'trigger threshold value', above which it will be declared sensitive to the end user. For example, a domestic garden or children's play area will have a low value relative to land designated for a commercial car park.

Site Preparation - when building on sites previously infilled with uncontaminated material, a reinforced raft-type foundation may be adequate for light structures. Larger buildings will justify soil consolidation and compaction processes to improve the bearing capacity. Remedial measures for subsoils containing chemicals or other contaminants are varied.

Legislation - the Environment Protection Act of 1990 attempted to enforce responsibility on local authorities to compile a register of all potentially contaminated land. This proved unrealistic and too costly due to inherent complexities. Since then, requirements under the Environment Act 1995, the Pollution Prevention and Control Act 1999, the PPC Regulations 2000 and the subsequent DCLG Planning Policy Statement (PPS 23, 2004): Planning and Pollution Control (Annex 2: Development on land affected by contamination) have made this more of a planning issue. It has become the responsibility of developers to conduct site investigations and to present details of proposed remedial measures as part of their planning application.

## Physical Treatment of Contaminated Subsoil

The traditional low-technology method for dealing with contaminated sites has been to excavate the soil and remove it to places licensed for depositing. However, with the increase in building work on brown-field sites, suitable dumps are becoming scarce. Added to this is the reluctance of ground operators to handle large volumes of this type of waste. Also, where excavations exceed depths of about 5m, it becomes less practical and too expensive. Alternative physical, biological or chemical methods of soil treatment may be considered.

Encapsulation - in-situ enclosure of the contaminated soil. A perimeter trench is taken down to rock or other sound strata and filled with an impervious agent such as bentonite clay. An impermeable horizontal capping is also required to link with the trenches. A high-specification barrier is necessary where liquid or gas contaminants are present as these can migrate quite easily. A system of monitoring soil condition is essential as the barrier may decay in time. Suitable for all types of contaminant.

Soil washing - involves extraction of the soil, sifting to remove large objects and placing it in a scrubbing unit resembling a huge concrete mixer. Within this unit water and detergents are added for a basic wash process, before pressure spraying to dissolve pollutants and to separate clay from silt. Eliminates fuels, metals and chemicals.

Vapour extraction - used to remove fuels or industrial solvents and other organic deposits. At variable depths, small diameter boreholes are located at frequent intervals. Attached to these are vacuum pipes to draw air through the contaminated soil. The contaminants are collected at a vapour treatment processing plant on the surface, treated and evaporated into the atmosphere. This is a slow process and it may take several months to cleanse a site.

Electrolysis - use of low voltage d.c. in the presence of metals. Electricity flows between an anode and cathode, where metal ions in water accumulate in a sump before pumping to the surface for treatment.

### BIOLOGICAL

Phytoremediation – the removal of contaminants by plants which will absorb harmful chemicals from the ground. The plants are subsequently harvested and destroyed. A variant uses fungal degradation of the contaminants.

Bioremediation – stimulating the growth of naturally occurring microbes. Microbes consume petrochemicals and oils, converting them to water and carbon dioxide. Conditions must be right, i.e. a temperature of at least 10°C with an adequate supply of nutrients and oxygen. Untreated soil can be excavated and placed over perforated piping, through which air is pumped to enhance the process prior to the soil being replaced.

### CHEMICAL

Oxidation – subsoil boreholes are used for the pumped distribution of liquid hydrogen peroxide or potassium permanganate. Chemicals and fuel deposits convert to water and carbon dioxide.

Solvent extraction – the subsoil is excavated and mixed with a solvent to break down oils, grease and chemicals that do not dissolve in water.

### THERMAL

Thermal treatment (off site) – an incineration process involving the use of a large heating container/oven. Soil is excavated, dried and crushed prior to heating to 2500°C, where harmful chemicals are removed by evaporation or fusion.

Thermal treatment (in-situ) – steam, hot water or hot air is pressure-injected through the soil. Variations include electric currents and radio waves to heat water in the ground to become steam. Evaporates chemicals.

Ref. Building Regulations, Approved Document, C1: Site preparation and resistance to contaminants. Section 1: Clearance or treatment of unsuitable material. Section 2: Resistance to contaminants.

*This page intentionally left blank*

## 5 SUPERSTRUCTURE – 1

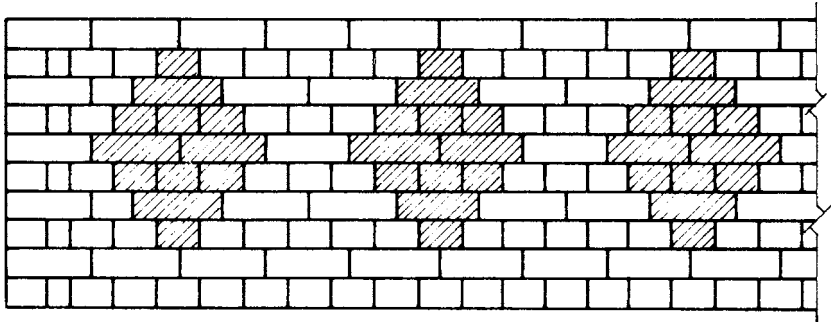

CHOICE OF MATERIALS  
BRICK AND BLOCK WALLS  
CAVITY WALLS  
DAMP-PROOF COURSES AND MEMBRANES  
GAS-RESISTANT MEMBRANES  
CALCULATED BRICKWORK MORTARS  
ARCHES AND OPENINGS  
WINDOWS, GLASS AND GLAZING  
DOMESTIC AND INDUSTRIAL DOORS  
CROSSWALL CONSTRUCTION  
FRAMED CONSTRUCTION  
RENDERING AND CLADDING EXTERNAL WALLS  
TIMBER PITCHED AND FLAT ROOFS  
GREEN ROOFS  
THERMAL INSULATION  
U-VALUE CALCULATION  
THERMAL BRIDGING  
ACCESS FOR THE DISABLED

# External Envelope – Choice of Materials

## STAGE 1

Consideration to be given to the following:

1. Building type and usage.
2. Building owner's requirements and preferences.
3. Local planning restrictions.
4. Legal restrictions and requirements.
5. Site restrictions.
6. Capital resources.
7. Future policy in terms of maintenance and adaptation.

## STAGE 2

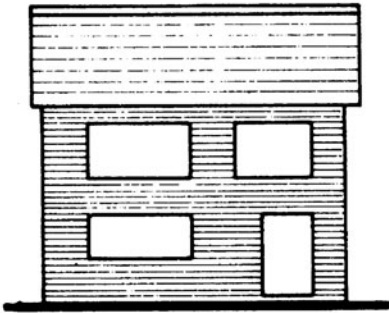

Decide on positions, sizes and shapes of openings

## STAGE 3

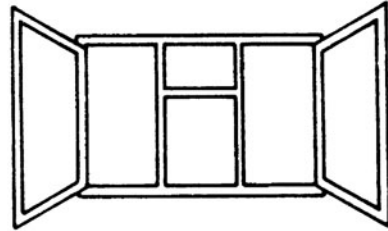

Decide on style, character and materials for openings

## STAGE 4

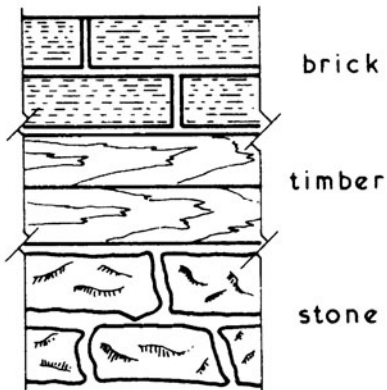

Decide on basic materials for fabric of roof and walls

## STAGE 5

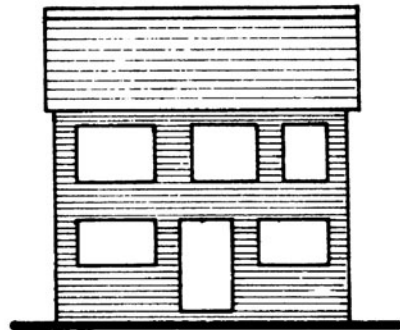

Review all decisions and make changes if required

Formation ~ millions of years ago planet earth originated as a ball of hot gases. Millions of years later the gases began to cool, solidify and liquefy to form large areas of land and seas. Today, a molten mass remains at the core, some 200 km below the surface, occasionally materialising in volcanic eruptions. The effect of cooling also created an atmospheric condition about the earth. As the gases solidified they formed into deposits of stone, varying in composition depending on their relative levels below the earth's crust and rate of cooling. Many of these stone deposits are materially suitable for building work and can be categorised under the following geological classifications:

- Igneous                                2560 – 3200 kg/m<sup>3</sup>
- Sedimentary                        1950 – 2750 ..
- Metamorphic                        2630 – 3040 ..

Igneous ~ originated from volcanic activity, formed by the crystallisation of molten rock. Can be sub-divided into:

*Plutonic* – solidified very slowly, deep into the lower part of the earth's surface, e.g. granite.

*Hypabyssal* – solidified less slowly, near to the earth's upper surface, e.g. porphyry.

*Volcanic* – solidified rapidly at the earth's outer surface, e.g. pumice.

Sedimentary ~ composed of particles of older rocks broken down by erosion due to the receding water levels that at one time covered much of the earth's surface. Fierce winds and ice also had a disintegrating effect on exposed stone deposits. Sedimentary deposits tend to lie in roughly horizontal stratified formations. These are sometimes loose as in sand and shingle, otherwise may be consolidated by superimposed loads with particles cemented together by minerals carried in water. In this dense form, sandstone and limestone can be shaped as building blocks. Chalk and shale are other examples.

Metamorphic ~ originally igneous or sedimentary, but changed structurally by geological processes involving heat, pressure and chemical reaction due to the presence of fluids. Examples include marble a form of metamorphic limestone, and slate a metamorphic clay.



## Stonework – Location

Sources ~ stones of various types occur worldwide. Some are mined, but most are reasonably accessible from surface workings at quarries. Removal is by blasting and then wedge cutting into slabs, blocks and thin sections of workable sizes. Thereafter it is sawn and split into commercial sizes, dressed and/or polished for final purpose. The UK and Ireland have many sources of stone to include the following:

Type	Location	Colour
Granite	Cornwall	Light grey
	Highlands and Western Isles	Bright grey to black
	Leicestershire	Various, light to dark
	Westmorland, Cumbria	Reddish brown
	Down, Ireland	Greenish grey
Limestone	Portland, Dorset	White to light brown
	Bath, West Country	White to cream
	Lincolnshire	Cream to buff
	Wiltshire	Light brown
	Somerset	Yellowish grey
	Kent	Blue grey
	Leicestershire	Cream to yellow
	Nottinghamshire	Yellowish brown
	Oxfordshire	Buff
Sandstone	Yorkshire	Grey and light brown
	Forest of Dean, Gloucs.	Grey/blue, grey/pink
	Gloucestershire	Dull blue
	Glamorganshire	Dull blue
	Derbyshire	Buff and light grey
	Sussex	Buff, brown specs
Marble	Dorset	Green/blue or grey
	Derbyshire	Light grey
	Argyllshire	Pale green/white
	Galway, Ireland	Green

Stonework is often a preferred alternative to brickwork, particularly where local planning requirements stipulate that vernacular characteristics are maintained.

Naturally Quarried Stones ~ these vary marginally in appearance, even when extracted in the same location from one quarry. Texture and slight colour variation adds to the character and visual attractiveness, along with the presence of veins, crystals, fossils and other visible features that manifest with wear and exposure.

Artificial Stones ~ otherwise known as reconstituted, reconstructed or cast stone. These are factory manufactured by casting natural stone aggregates of 15 mm maximum size with white or coloured cement into moulds of a specific dimensions. The usual ratio is 3 to 4 parts of aggregate to 1 part cement. These defect free blocks produced under quality controlled conditions are an economical substitute for natural stone. Block sizes can vary to suit specific applications, but colour and texture are uniform. A variation is a 20 to 25 mm facing of natural stone aggregate, fine sand aggregate and cement (possibly colour pigmented) set over a base of wet concrete.

Further working of cast stone can produce a high quality surface finish to very accurate overall dimensions. In this precise form, blocks can be used as an artificial type of ashlar facing over brickwork or standard blockwork backgrounds, (see below for a definition of ashlar and next page for a summary of ashlar walling).

The long term weathering qualities of cast stone differ from that of natural stone. Natural stone weathers slowly with a gradual and fairly consistent colour change. Artificial stone has the characteristics of concrete. With time it may crack, become dull and attract dirt staining at joints, corners and projecting features such as copings and sills.

Ashlar ~ hewn and dressed stone facing block.

Ashlaring ~ stonework comprising blocks of stone finely squared and dressed to a precise finish and dimensions, laid to courses of not less than 300 mm in height.

Refs.: BS 1217: Cast stone. Specification.

BS EN 771-5: Specification for masonry units. Manufactured stone masonry units.

## Stonework – Ashlar Walling

Ashlaring ~ as defined on the preceding page, a wall facing of high quality stone laid with very thin joints. It is a classic façade treatment to many existing prestigious buildings, but now rarely used due to the cost of manufacturing the stone to fine tolerances and the time consuming craftsmanship required for construction. Examples are included here not just for historical reference; many buildings constructed with ashlar walling are the subject of ongoing refurbishment, conversion, modification, adaptation and repair. Limestone is popular for ashlar, produced in thicknesses between 100 and 300 mm and bedded in a mortar known as mason's putty. The traditional mix for this mortar comprises stone dust, lime putty and portland cement in the ratio of 7:5:2.

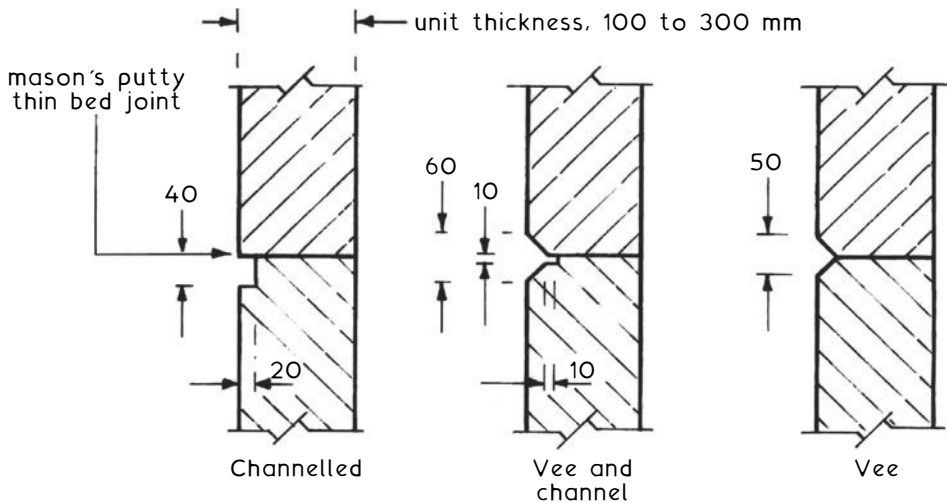

Examples of joint profiles to ashlar walling units (dimensions in mm)

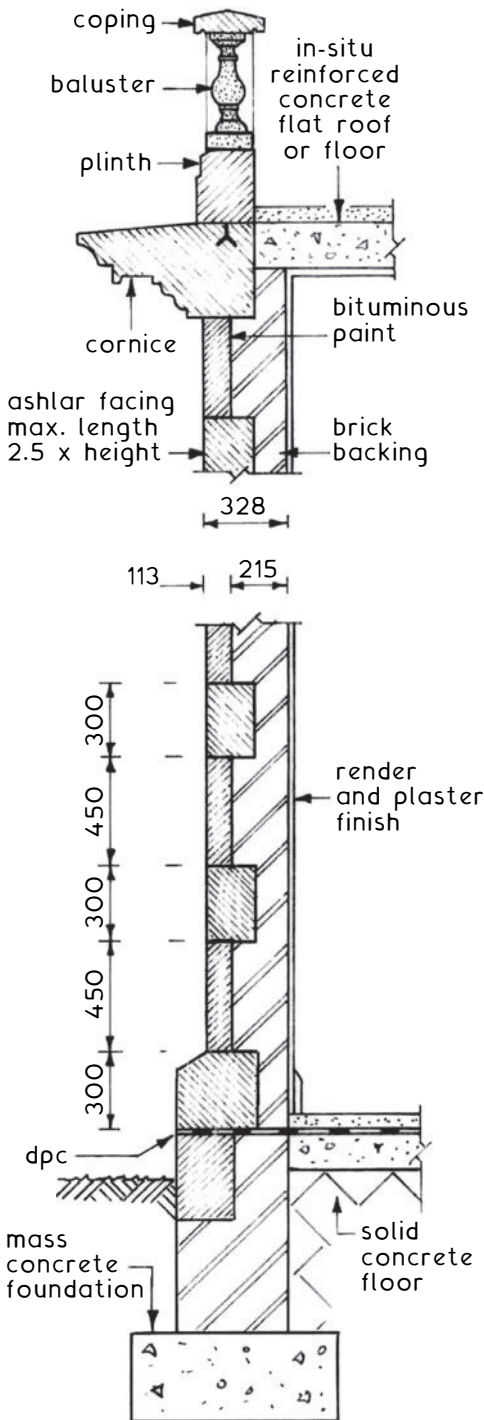

Construction shown here is a reference to existing practice. In established towns and cities there are often many examples of ashlar stonework faced buildings. Not all are smooth faced as the stone sometimes features surface patterning.

A contemporary variation of the ashlar effect is achieved with cavity wall construction, where artificial or cast stone is deployed over the whole façade (similar to the detail on page 378). This effect can be used on a limited scale using the cast stone as an isolated feature, e.g. at quoins, sills and around openings for doors and windows. The ashlar effect can also be replicated in medium and high rise buildings by using cast stone (concrete) cladding. The principles of this are shown in Part 6.

Example of existing ashlar stonework (dimensions in mm)

## Stonework – Rubble Walling

Rubble Walls ~ walls constructed of stones used either in a random rough or uneven form as extracted from the quarry, or roughly dressed to a square or rectangular shape. Walls of this type are common in rural areas, particularly those close to quarry locations. Many walls are dry bonded as estate and farm boundaries. Otherwise, stones are laid with a relatively deep bed joint of mortar to accommodate irregularities, often as garden features and external walls to dwellings. Lime based mortar is preferred with long runs of stone walling as it is less prone to thermal movement cracking than cement mortar.

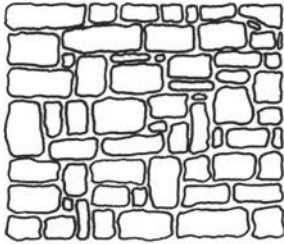

Random rubble  
uncoursed

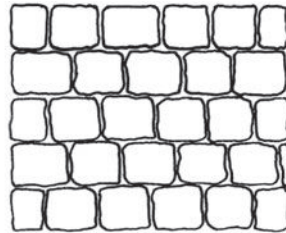

Square random  
rubble

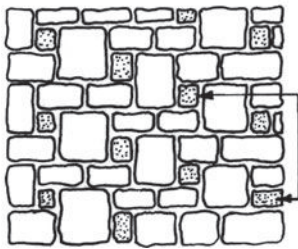

Squared random  
rubble with  
through snecks

brick lacing  
provides  
strength  
and feature

snecks min.  
50 mm  
dimension

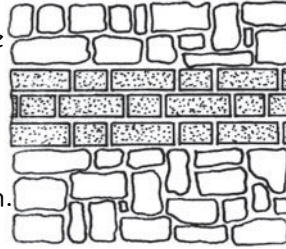

Random rubble  
with brick lacing

Common Treatment at Dressed Stone Arch Openings ~ examples show rubble walling to the left and ashlar to the right.

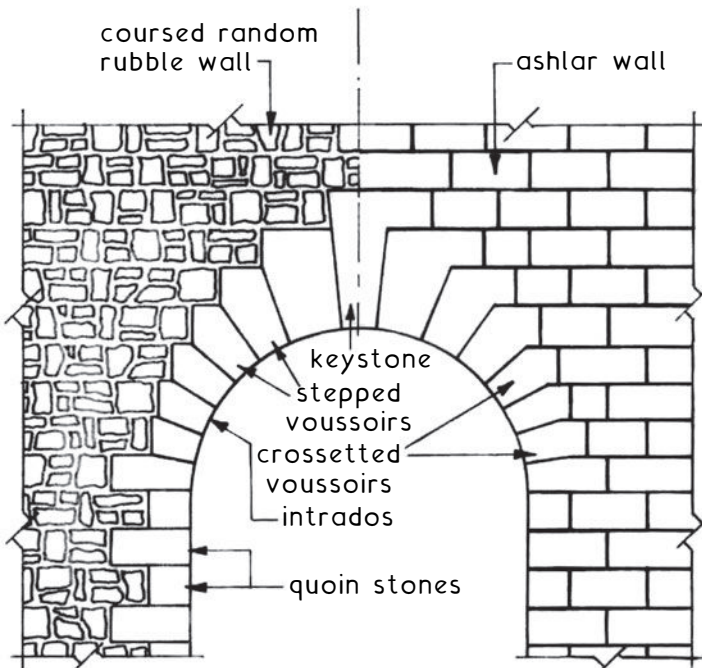
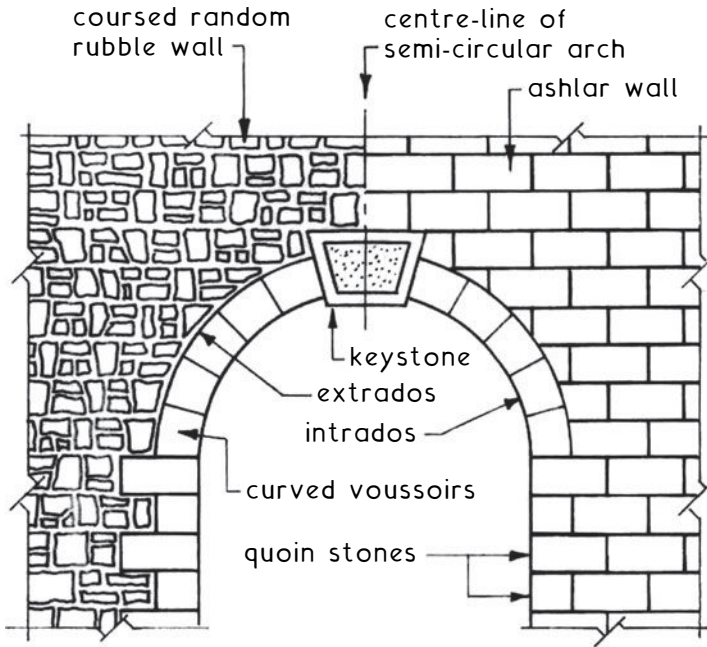

## Stonework – Cavity Wall

In many areas where locally quarried stone is the established building material, traditions are maintained and specified as part of planning compliance requirements. Dressed stone is an example of an established external feature and can be used as an alternative to brickwork as the outer leaf of cavity walls. Stone widths of 150 to 225 mm are usual, although as little as 100 mm is possible with mechanically cut and finished stone. However, this type of precise finishing produces an effect resembling ashlar rather than rubble. A lightweight concrete block inner leaf provides lateral support and stability with wall ties positioned at the maximum spacings shown on page 400.

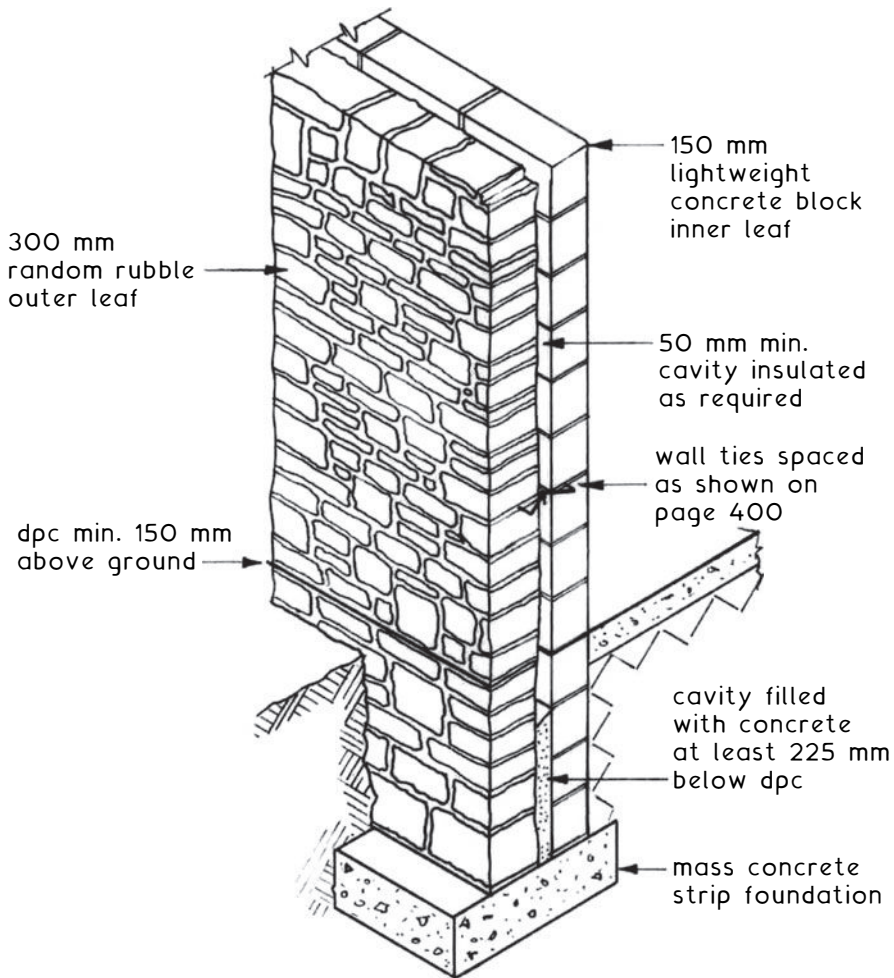

Note: Solid walls of stone need to be at least 300 mm wide to ensure stability; in excess of 400 mm (depending on quality) to resist penetration of rainfall.

Shaping and Moulding ~ bricks were originally made by hand kneading clay into an open wooden box. The box dimensions typically 250 mm × 125 mm × 75 mm (10'' × 5'' × 3') with a protrusion in the bottom if a *frog* or indent was required as a mortar key. Oversized dimensions allowed for shrinkage.

Drying and Burning ~ after surplus clay was struck off, the *green* brick was turned out of the mould and stacked with others in a drying shed for 3 to 6 weeks. The bricks were then burnt in open *clamps*. This involved stacking in open flue formations to a height of 3 to 4 metres with layers of fine coal laid between the bricks. Fine particles of coal could also be mixed with the clay during the moulding process. On setting the *clamp*, fires were placed and ignited leaving the bricks to burn for several days. Bricks were produced in this way by the Romans and more so during the Middle Ages. There is evidence that the Babylonians used this procedure over 6000 years ago.

Hardwood hand mould or frame for standard size clay bricks

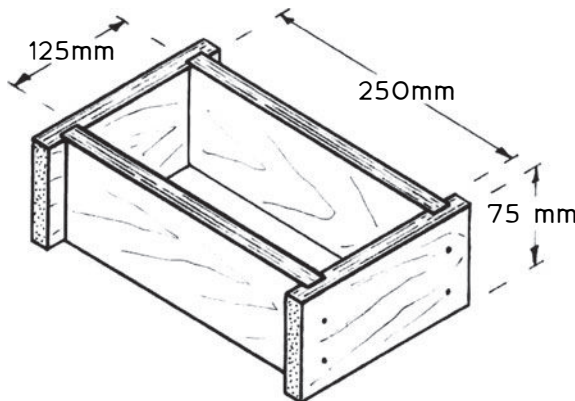

Outline examples of moulds for hand made purpose made specials

Double cant Birdsmouth

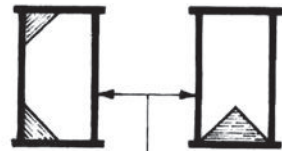

frame

Single angle Dog-leg



inserts

Notes:

- *Clamp* burning is still used by some of the smaller brick companies, but most producers now use controlled kiln burning as described on the next page.
- Bricks made with fine coal deposits have characteristic purple/blue markings. They have become known as *stocks*.
- Small batch orders for purpose made bricks as shown on page 396, are still made by hand in specially shaped moulds.



## Clay Brick Manufacture – Development

Machine Manufacture ~ during the industrial revolution (mid 18th. to 19th. centuries) greater demand for bricks led to brick production on an industrial scale. Machinery was introduced to mass produce pressed bricks in moulds and for wire cutting extruded clay. Both techniques are the basis of production today. Wire cutting to size is used where clay is mechanically forced through a brick sized opening. Circular bars in the central area of the opening leave two or three perforations to provide for a mortar key when laid.

Kiln Drying and Firing ~ in 1858 the German, Friedrich Hoffmann devised the circular or oval kiln system containing several chambers. The chambers have loading doors, fire holes and flues connecting to a common chimney. Each chamber represents a different stage of drying, pre-heating, firing\* (1100 °C) and cooling, all of which are undertaken on a large scale without transportation. A later development is the straight tunnel kiln with a central firing zone. With this, bricks stacked on trolleys run on a narrow railway line through slowly increasing and decreasing heat zones. Both types of kiln are used today, although the tunnel is generally preferred as this is easier to control.

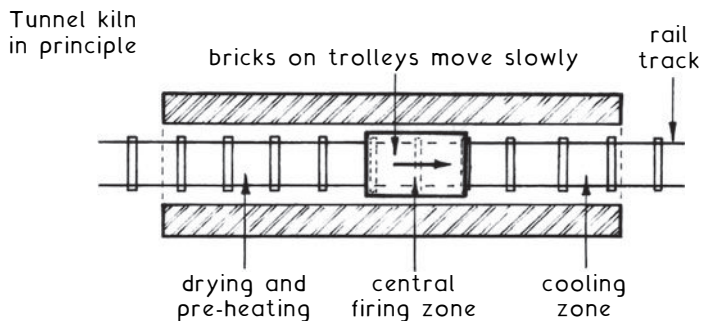
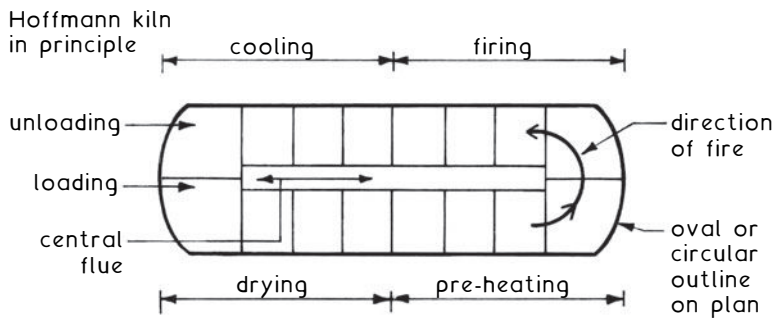

\* Fired using natural gas, fuel oil or solid fuel.

## Calcium Silicate (Sand-Lime) Brick Manufacture

History ~ originated during the 19th. century as a form of cast artificial stone. Caustic lime and sand were mixed with water into a workable consistency and left until the lime was completely hydrated. It was then pressed into moulds for steam curing and initial hardening. After dry stacking for several weeks the bricks matured to a usable strength.

Development ~ by the end of the 19th. century, processing was considerably improved. Steam at 200°C was pressurised in an *autoclave* (a sealed vessel used to create a chemical reaction between the lime and sand under high pressure; approximately 15 bar or 1.5 MN/m<sup>2</sup>). The reaction formed hydrosilicates (hydrated calcium silicates) resulting in an extremely durable and strong building brick. This principle is the basis for calcium silicate brick production today.

Typical Composition ~ Silica (sand) 84%

Lime (quicklime or hydrated lime) 7%

Alumina and oxide of lime 2%

Water, manganese and alkalis 7%

Properties ~ Similar production costs to clay brick manufacture  
High crushing strength (see below)  
Dimensionally accurate, ie. edges straight, even and without defects, warping or twisting  
Uniformity of dull white colour and of texture (perceived as uninteresting by some)

Variations ~ Flint-lime, produced by adding powdered flint  
Colouring agents; options for buffs, blues, mauves, etc.

Typical Brick Compressive Strength Comparisons ~

Hand made clay - 6 to 14 MN/m<sup>2</sup>

Machine made clay - 15 to 20 MN/m<sup>2</sup>

Stock (clay) - 10 to 20 MN/m<sup>2</sup>

Engineering brick (clay) - 50 to 70 MN/m<sup>2</sup>

Sand-lime - 20 to 50 MN/m<sup>2</sup> (see BS EN 771-2)

Environmental Impact ~ due to less energy fuel use in production and without generating the air pollutants that occur with clay brick manufacture, considered to have a relative low environmental impact.

# Solid Brick Walls

Bricks ~ these are walling units within a length of 337.5 mm, a width of 225 mm and a height of 112.5 mm. The usual size of bricks in common use is length 215 mm, width 102.5 mm and height 65 mm and like blocks they must be laid in a definite pattern or bond if they are to form a structural wall. Bricks are usually made from clay (BS EN 771-1) or from sand and lime (BS EN 771-2) and are available in a wide variety of strengths, types, textures, colours and special shaped bricks to BS 4729.

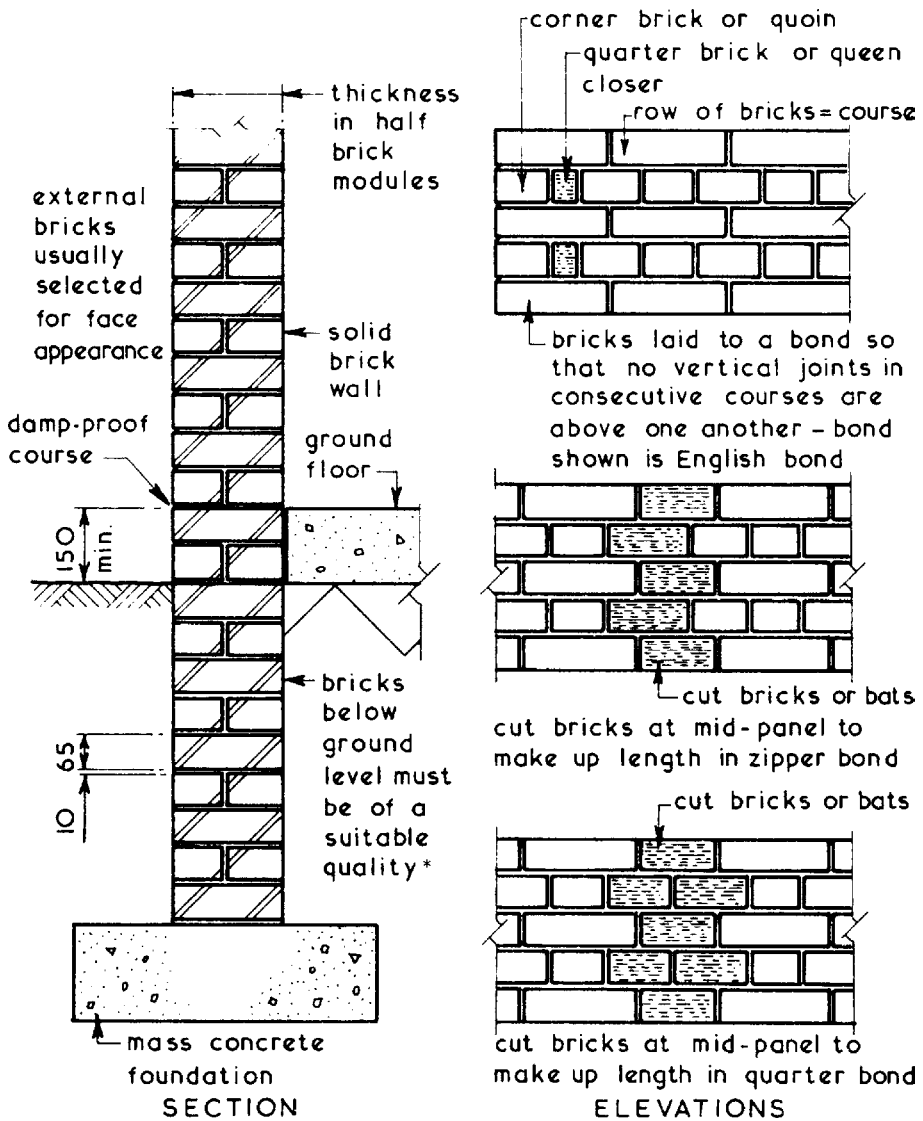

\*see pages 401 to 403.

Typical Details ~

Bonding ~ an arrangement of bricks in a wall, column or pier laid to a set pattern to maintain an adequate lap.

Purposes of Brick Bonding:

1. Obtain maximum strength whilst distributing the loads to be carried throughout the wall, column or pier.
2. Ensure lateral stability and resistance to side thrusts.
3. Create an acceptable appearance.

Lap Forms ~

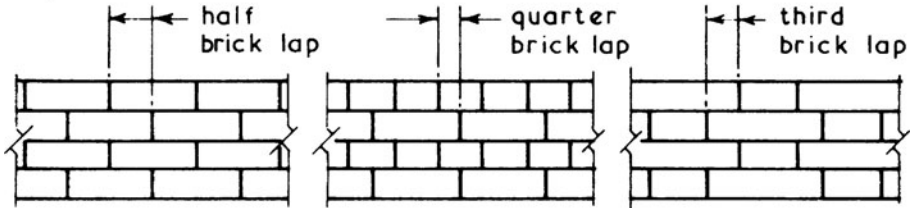

**HALF BONDING**  
used in half brick thick walls built in stretcher bond

**QUARTER BONDING**  
used in most bonds built with standard bricks

**THIRD BONDING**  
used in bonds built with metric bricks

Simple Bonding Rules:

1. Bond is set out along length of wall working from each end to ensure that no vertical joints are above one another in consecutive courses.

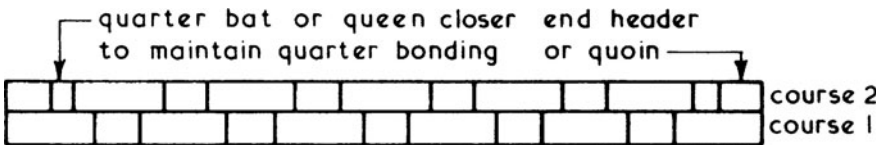

NB all odd numbered courses set out as course 1 and all even numbered courses set out as course 2

2. Walls which are not in exact bond length can be set out thus -

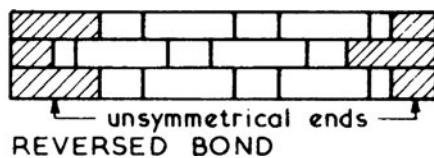
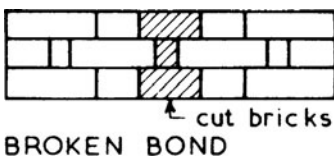

3. Transverse or cross joints continue unbroken across the width of wall unless stopped by a face stretcher.

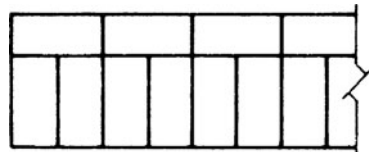

# Brick Bonding – English Bond

English Bond ~ formed by laying alternate courses of stretchers and headers it is one of the strongest bonds but it will require more facing bricks than other bonds (89 facing bricks per m<sup>2</sup>).

Typical Example ~

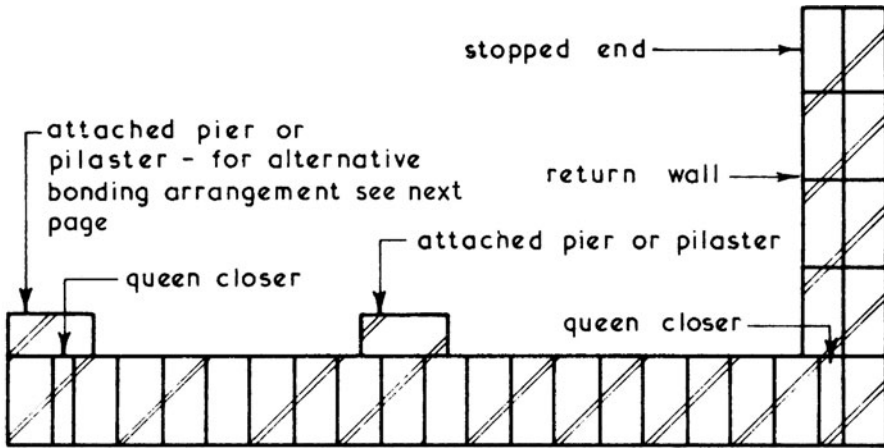

PLAN ON ODD NUMBERED COURSES

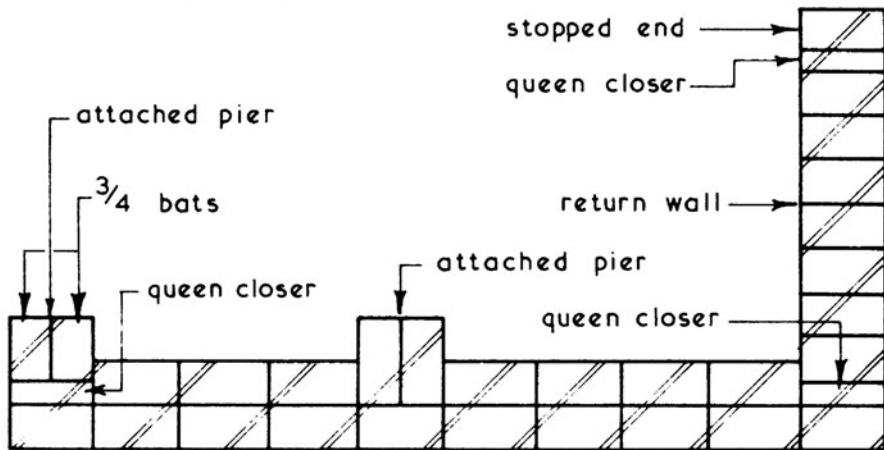

PLAN ON EVEN NUMBERED COURSES

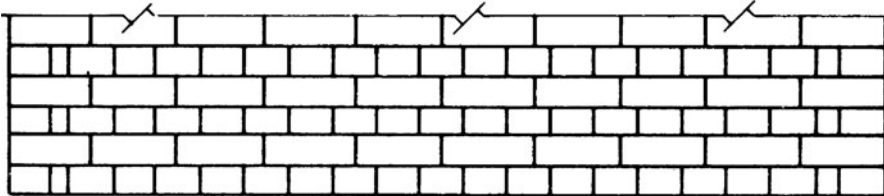

ELEVATION

Flemish Bond ~ formed by laying headers and stretchers alternately in each course. Not as strong as English bond but is considered to be aesthetically superior and uses less facing bricks (79 facing bricks per m<sup>2</sup>).

Typical Example ~

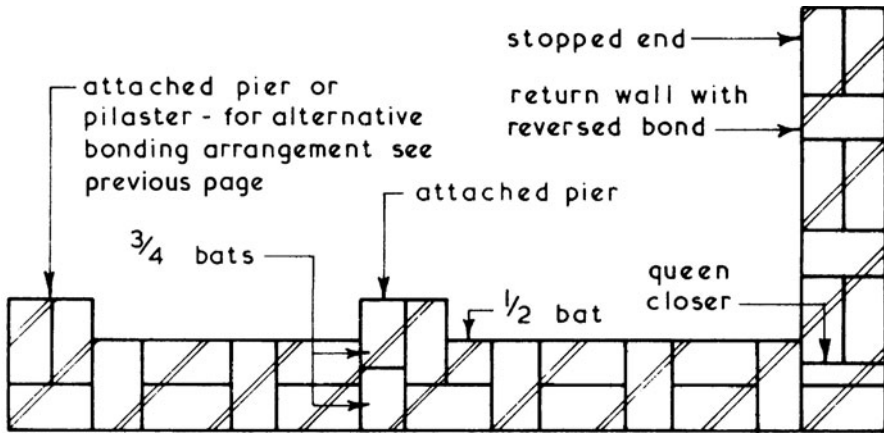

PLAN ON ODD NUMBERED COURSES

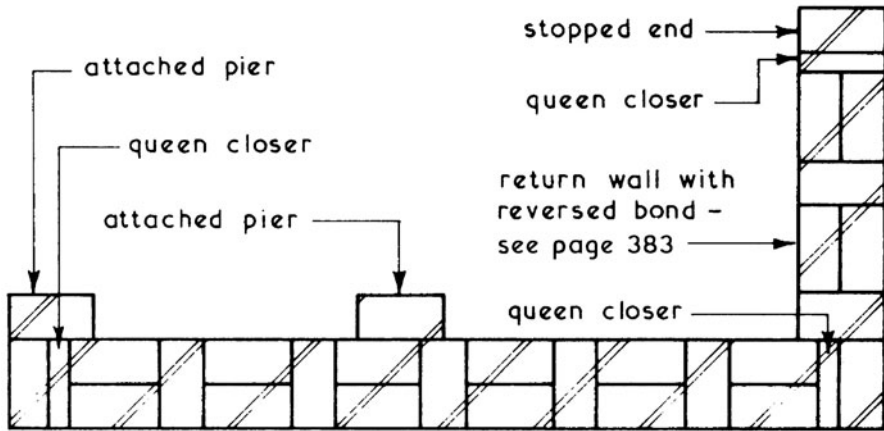

PLAN ON EVEN NUMBERED COURSES

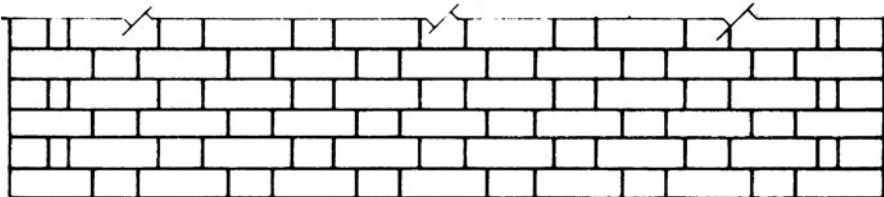

ELEVATION

# Brick Bonding – Special Bonds

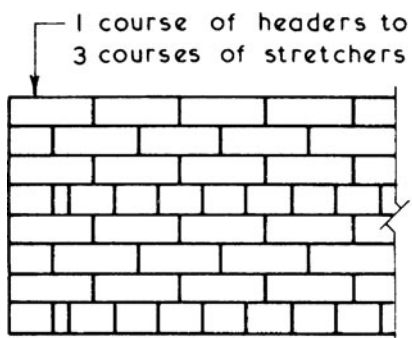

**ENGLISH GARDEN WALL BOND** - gives quick lateral spread of load - uses less facings than English bond.

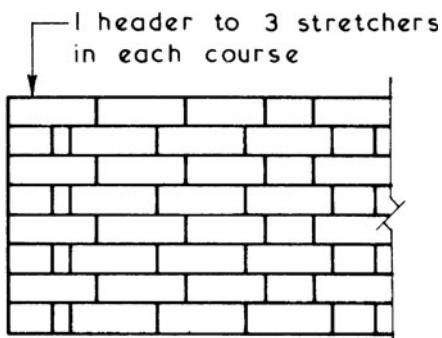

**FLEMISH GARDEN WALL BOND** - enables a fair face to be kept on both sides of a one brick thick wall.

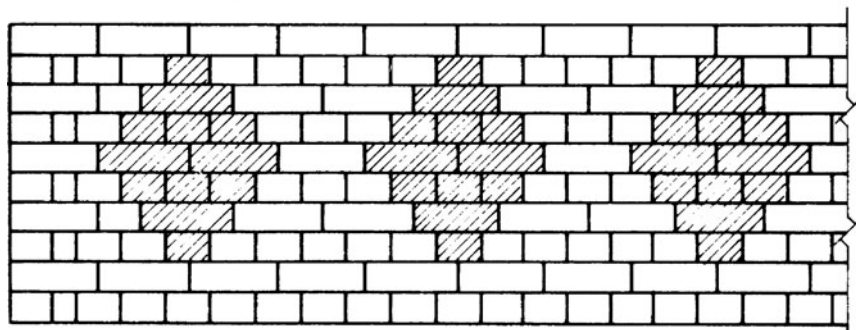

**ENGLISH CROSS BOND** - header placed next to end stretcher in every other stretcher course which thus staggers stretchers enabling patterns or diapers to be picked out in different texture or coloured bricks.

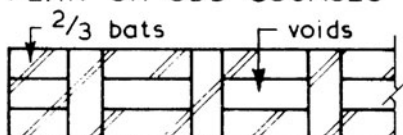
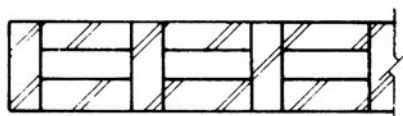
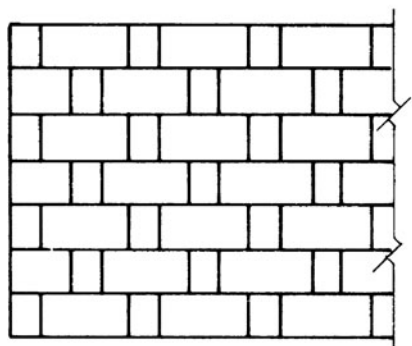

**RAT TRAP BOND** - uses brick on edge courses - hollow pockets or voids reduce total weight of wall and by the bricks on edge there is an overall saving of materials.

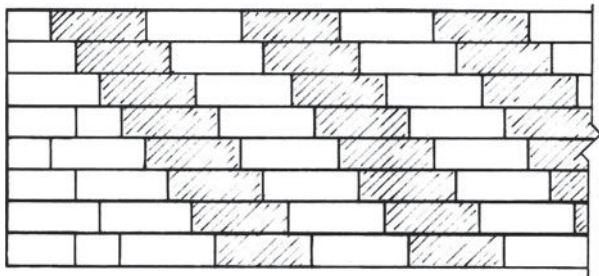

RAKING STRETCHER BOND

A variation of stretcher bond with less symmetry of load distribution. Each brick overlaps the brick below by a quarter.

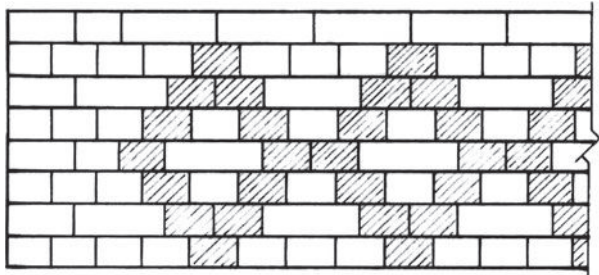

DUTCH BOND

Similar to English cross bond using bricks of colour or texture variation to create a pattern. Three quarter bricks are used at ends instead of queen closers.

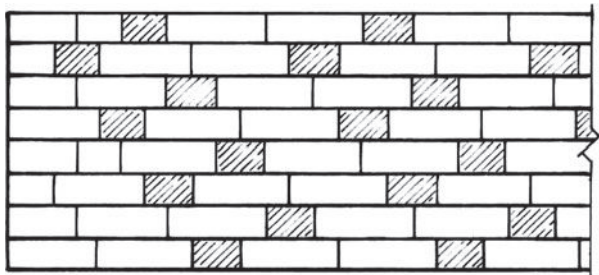

MONK BOND

Two stretcher faces to one header each course. Headers stagger and may be picked out in colour or texture differing to the stretchers. Many variations of monk bond exist.

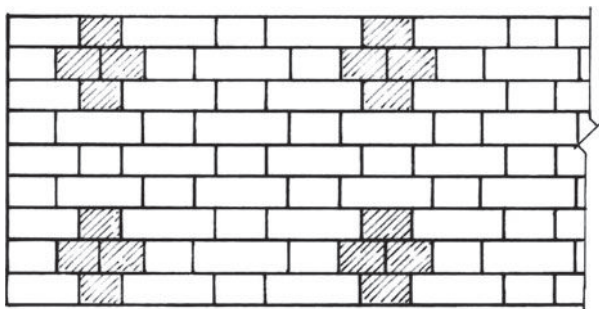

FLEMISH CROSS BOND

Similar to Flemish bond. Two headers replace a stretcher every seventh course. Coloured or textured bricks pick out diamond shapes.



## Brick Bonding – Stack Bond

Stack Bonding – the quickest, easiest and most economical bond to lay, as there is no need to cut bricks or to provide special sizes. Visually the wall appears unbonded as continuity of vertical joints is structurally unsound, unless wire bed-joint reinforcement is placed in every horizontal course, or alternate courses where loading is moderate. In cavity walls, wall ties should be closer than normal at 600 mm max. spacing horizontally and 225 mm max. spacing vertically and staggered.

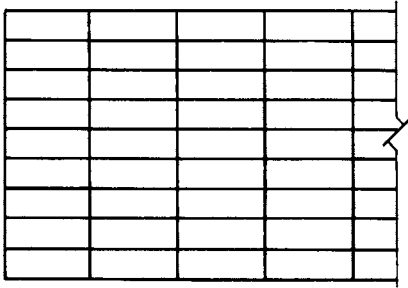

Horizontal stack bond

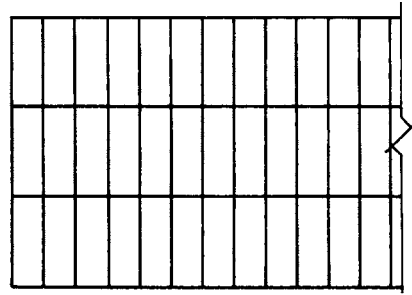

Vertical stack bond

Application – this distinctive uniform pattern is popular as non-structural infill panelling to framed buildings and for non-load bearing exposed brickwork partitions.

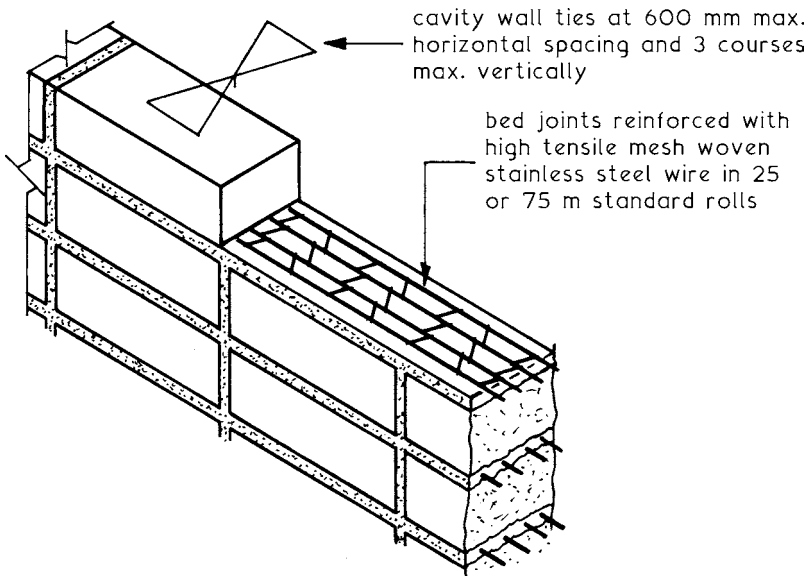

Reinforced stack bond

Attached Piers ~ the main function of an attached pier is to give lateral support to the wall of which it forms part from the base to the top of the wall. It also has the subsidiary function of dividing a wall into distinct lengths whereby each length can be considered as a wall. Generally walls must be tied at end to an attached pier, buttressing or return wall.

Typical Examples ~

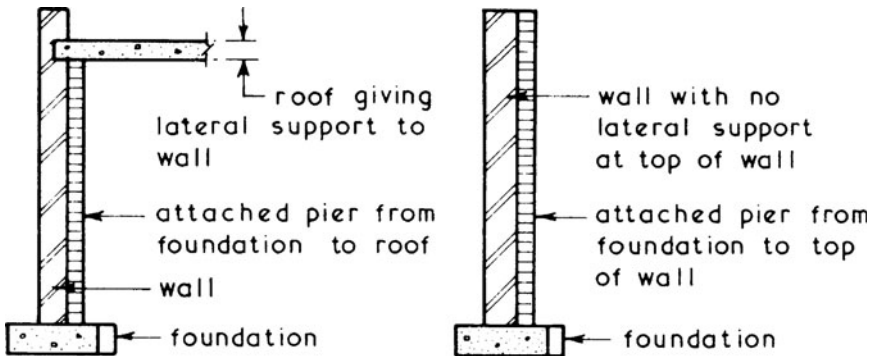

Requirements for the external wall of a small single storey non-residential building or annex exceeding 2.5 m in length or height and of floor area not exceeding 36 m<sup>2</sup>:

- Minimum thickness, 90 mm, i.e. 102.5 mm brick or 100 mm block.
- Built solid of bonded brick or block masonry and bedded in cement mortar.
- Surface mass of masonry, minimum 130 kg/m<sup>2</sup> where floor area exceeds 10 m<sup>2</sup>.
- No lateral loading permitted excepting wind loads.
- Maximum length or width not greater than 9 m.
- Maximum height as shown on page 391.
- Lateral restraint provided by direct bearing of roof and as shown on page 543.
- Maximum of two major openings in one wall of the building. Height maximum 2.1m, width maximum 5 m (if two openings, total width maximum 5 m).
- Other small openings permitted, as shown on next page.
- Bonded or connected to piers of minimum size 390 × 190 mm at maximum 3 m centres for the full wall height as shown above. Pier connections are with pairs of wall ties of 20 × 3 mm flat stainless steel type at 300 mm vertical spacing.

## Attached Piers

Attached piers as applied to half brick (90mm min.) thick walls ~

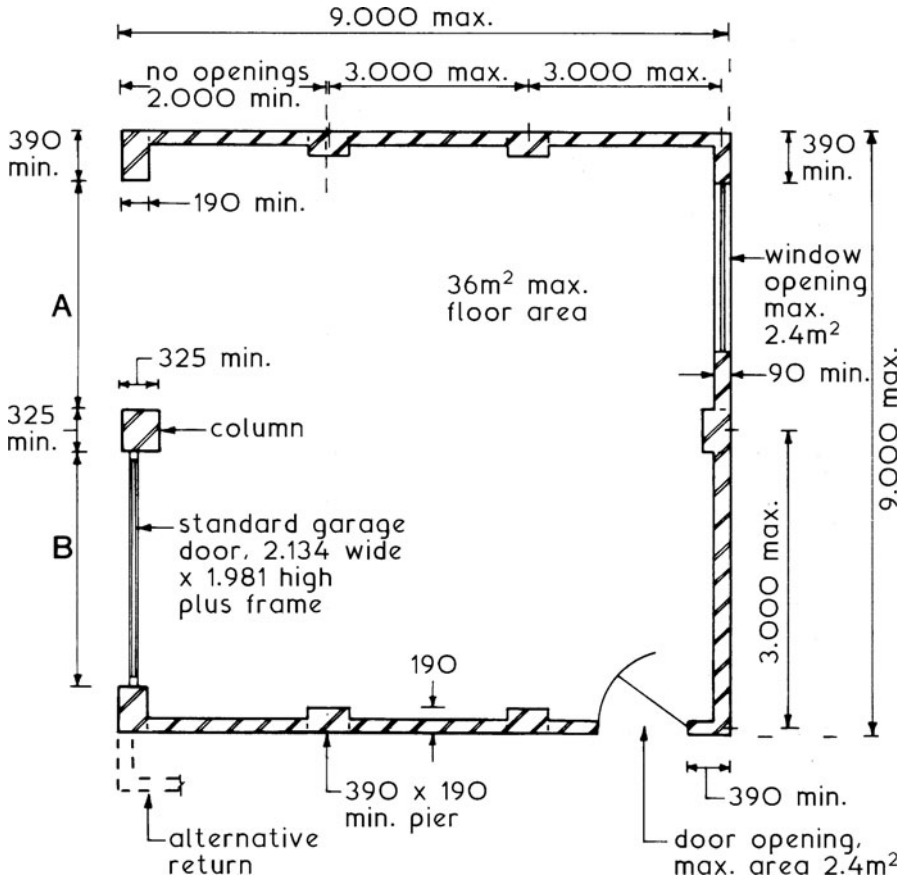

- Major openings A and B are permitted in one wall only. Aggregate width is 5m maximum. Height not greater than 2.1m. No other openings within 2m.
- Other walls not containing a major opening can have smaller openings of maximum aggregate area 2.4m<sup>2</sup>.
- Maximum of only one opening between piers.
- Distance from external corner of a wall to an opening at least 390mm unless the corner contains a pier.
- The minimum pier dimension of 390 × 190 mm can be varied to 327 × 215 mm to suit brick sizes.

Construction of half brick and 100 mm thick solid concrete block walls (90 mm min.) with attached piers, has height limitations to maintain stability. The height of these buildings will vary depending on the roof profile; it should not exceed the lesser value in the following examples ~

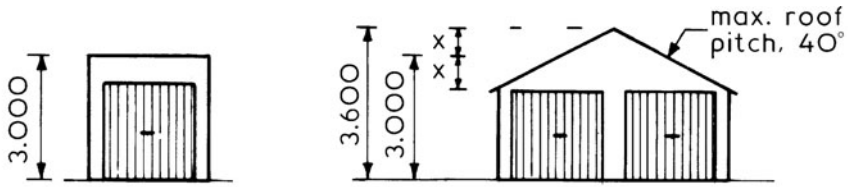

Detached non-residential garages and workshops

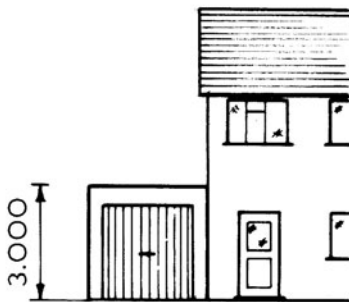

Flat roof garage attachment

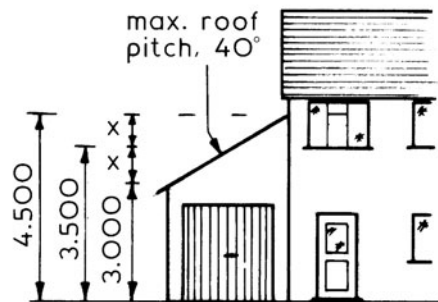

Lean-to garage attachment

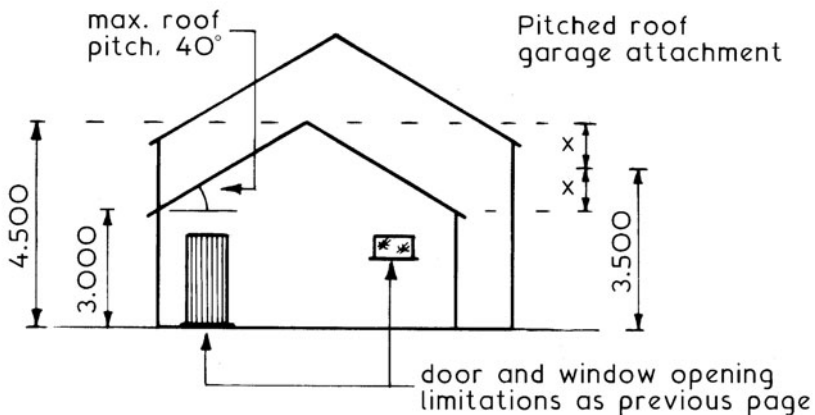

NB. All dimensions are maximum.

Height is measured from top of foundation to top of wall except where shown at an intermediate position. Where the underside of the floor slab provides an effective lateral restraint, measurements may be taken from here.

## Brickwork – Movement Control

Movement ~ caused by building settlement, moisture absorption and drying out and thermal expansion and contraction.

Effects ~ provided the mortar is weaker than the bricks, the effects of movement within normal expectations will be accommodated without unsightly cracking and damage. See page 423 for guidance on mortar composition and strengths.

Limitations ~ moisture and thermal movement is reversible up to a limit. Clay brick walls can move about 1mm in every 1m of wall, so for a visually and practically acceptable movement joint width of 12 mm, the spacing should not exceed 12 m. For calcium silicate (sand-lime) bricks the maximum spacing is 9 m as they have greater movement characteristics.

Applications ~

Plan Views

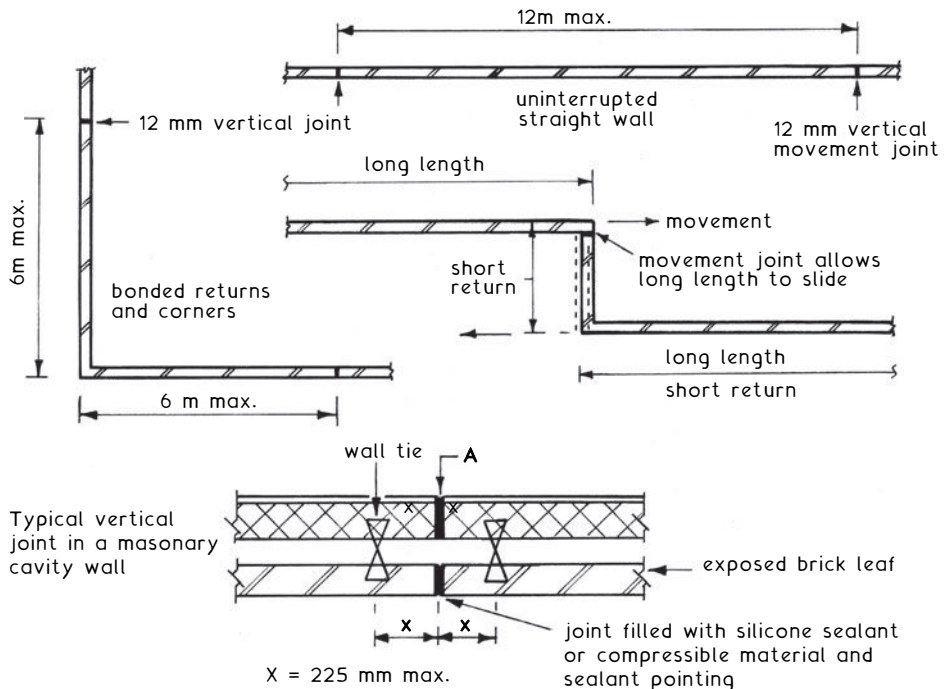

Note: Joint at A in blockwork at 6 m max. spcing may be staggered, i.e. not directly opposite joint in brickwork to promote integrity and to reduce differential movement.

See page 734 for lightweight concrete block walls.

The appearance of a building can be significantly influenced by the mortar finishing treatment to masonry. Finishing may be achieved by jointing or pointing.

Jointing – the finish applied to mortar joints as the work proceeds.

Pointing – the process of removing semi-set mortar to a depth of about 20mm and replacing it with fresh mortar. Pointing may contain a colouring pigment to further enhance the masonry.

Finish Profiles. Typical Examples Shown Pointed ~

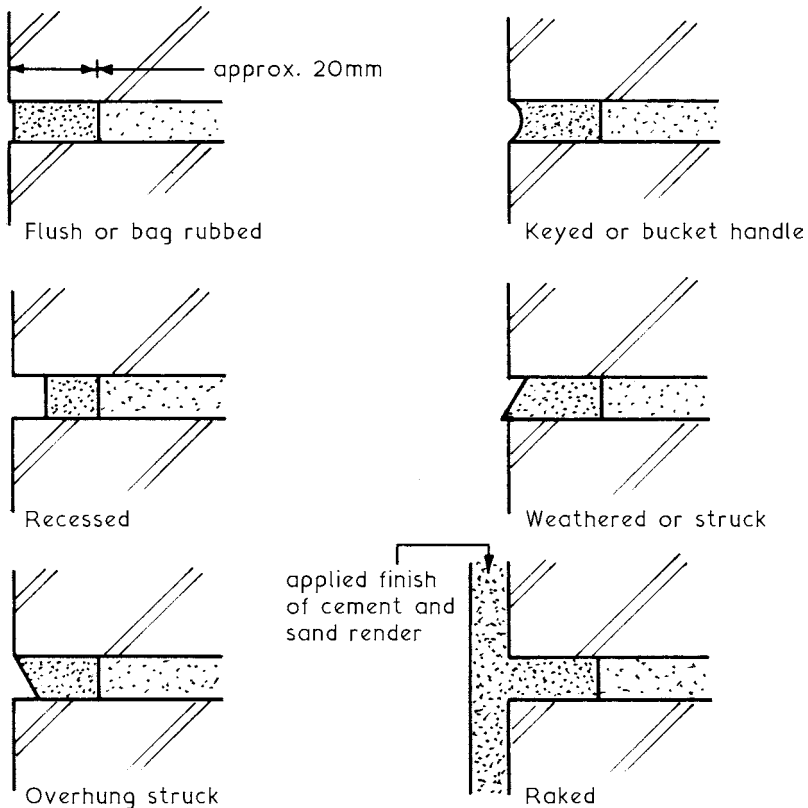

Examples of pointing to masonry

NB. Recessed and overhung finishes should not be used in exposed situations, as rainwater can be detained. This could encourage damage by frost action and growth of lichens.

## Brickwork – Jointing Tolerances

Brickwork should be reasonably uniform in colour, texture and finish. The natural composition of clay source material is variable, even where closely extracted. Combined with kiln baking to about  $1100^{\circ}\text{C}$ , no two bricks will be identical in dimensions and shape. Therefore, some allowance for characteristic irregularities of individual units is acceptable, see page 132. When assessing acceptable thickness and tolerance of brickwork joints, overall areas are considered and not the joints between individual units.

Note: Sand lime (calcium silicate) bricks are an exception. These are produced to relatively precise dimensional tolerances with a uniformity of colour and texture, see page 381.

### Bed Joints, Deviation From the Horizontal ~

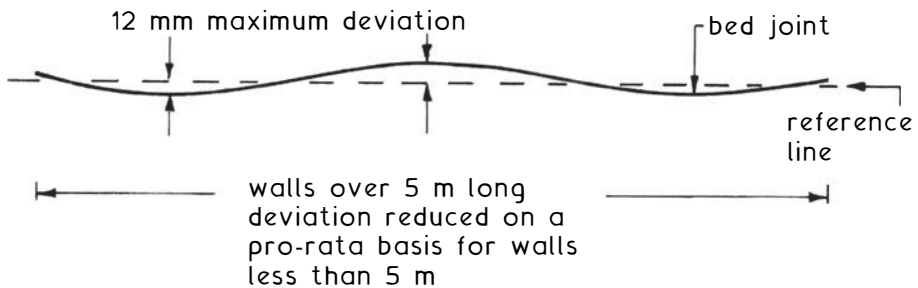

### Bed Joints, Thickness ~

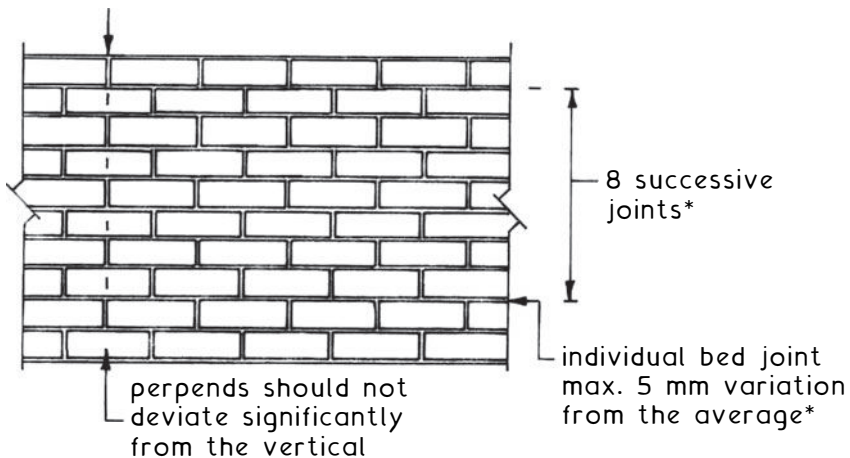

Specials – these are required for feature work and application to various bonds, as shown on the preceding pages. Bonding is not solely for aesthetic enhancement. In many applications, e.g. English bonded manhole walls, the disposition of bricks is to maximise wall strength and integrity. In a masonry wall the amount of overlap should not be less than one quarter of a brick length. Specials may be machine or hand cut from standard bricks, or they may be purchased as purpose-made. These purpose-made bricks are relatively expensive as they are individually manufactured in hardwood moulds.

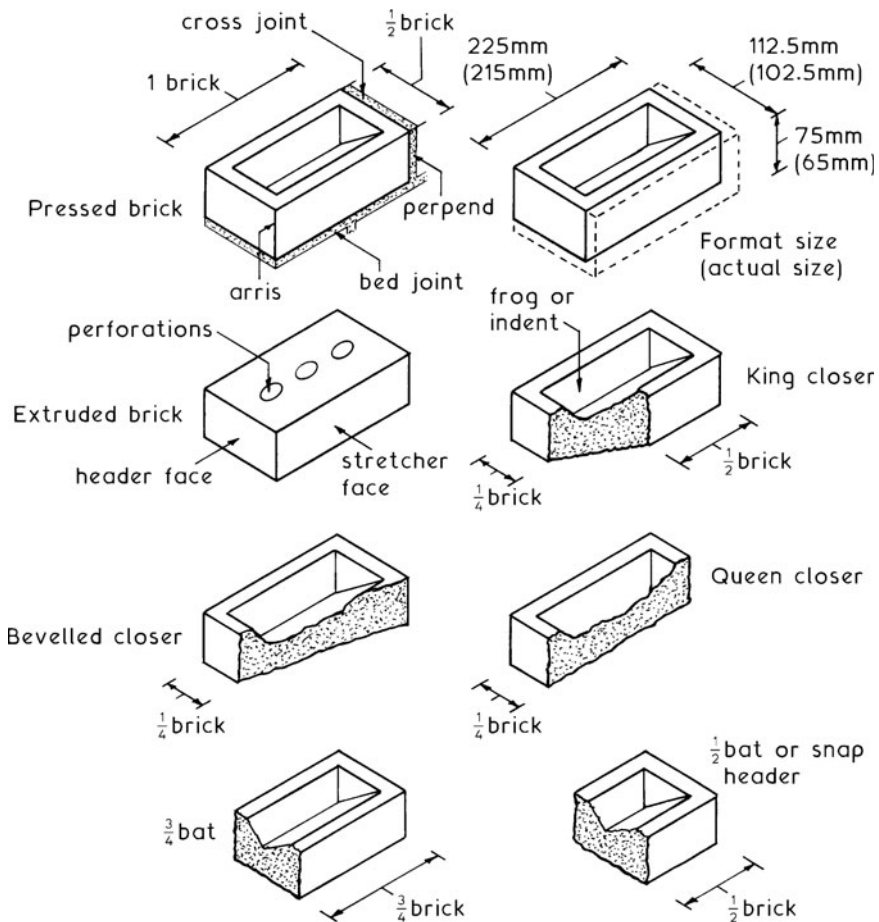

Standard bricks and cut specials

Ref. BS 4729: Clay and calcium silicate bricks of special shapes and sizes. Recommendations.



## Purpose-made Special Bricks

Brickwork can be repetitive and monotonous, but with a little imagination and skilled application it can be a highly decorative art form. Artistic potential is made possible by the variety of naturally occurring brick colours, textures and finishes, the latter often applied as a sanding to soft clay prior to baking. Furthermore, the range of pointing techniques, mortar colourings, brick shapes and profiles can combine to create countless possibilities for architectural expression.

Bricks are manufactured from baked clay, autoclaved sand/lime or concrete. Clay is ideally suited to hand making special shapes in hardwood moulds. Some popular formats are shown below, but there is no limit to creative possibilities.

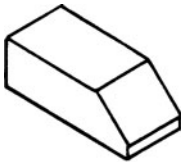

plinth header  
215mm long

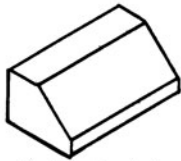

plinth stretcher  
102.5mm wide

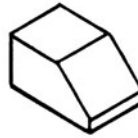

plinth wide-bed  
158mm long

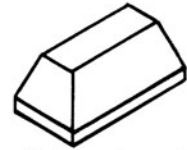

plinth external  
return

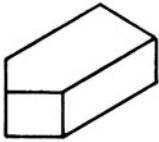

squint angle

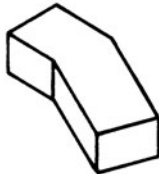

angle brick

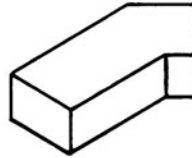

dog-leg brick

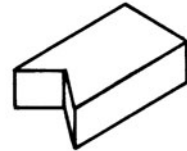

birdsmouth

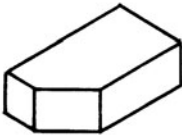

cant

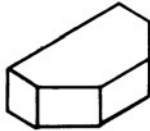

double cant

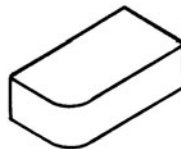

single bullnose

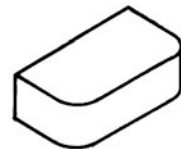

double bullnose

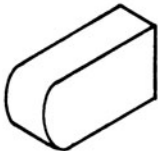

bullnose on end  
(cow nose)

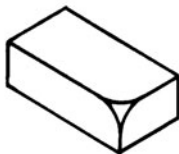

bullnose mitre

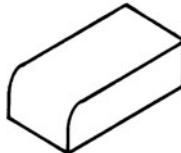

single bullnose  
header

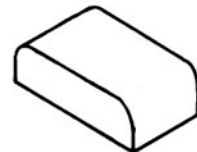

double-headed  
bullnose

Purpose-made and special shape bricks

Plinths – used as a projecting feature to enhance external wall appearance at its base. The exposed projection determines that only frost-proof quality bricks are suitable and that recessed or raked-out joints which could retain water must be avoided.

Typical External Wall Base –

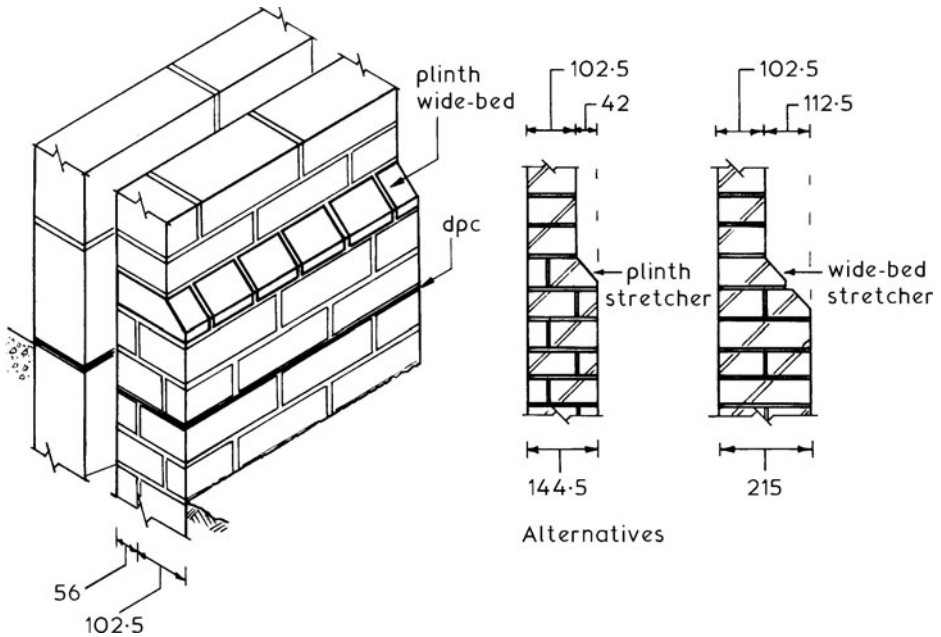

Corbel – a projecting feature at higher levels of a building. This may be created by using plinth bricks laid upside-down with header and stretcher formats maintaining bond. For structural integrity, the amount of projection (P) must not exceed one-third of the overall wall thickness (T). Some other types of corbel are shown on the next page.

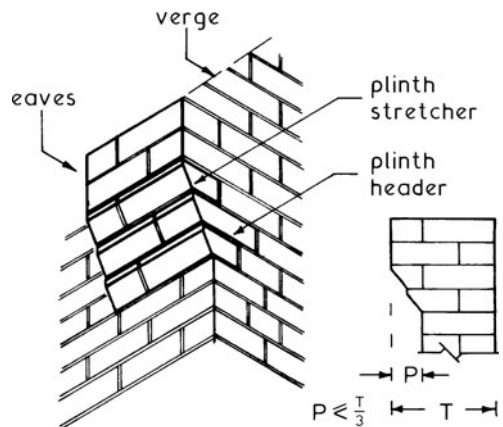

Corbel feature at junction of eaves and verge

## Special Bricks – Corbels, Dentils and Dog Tothing

Corbel - a type of inverted plinth, generally located at the higher levels of a building to create a feature. A typical example is quarter bonded headers as a detail below window openings.

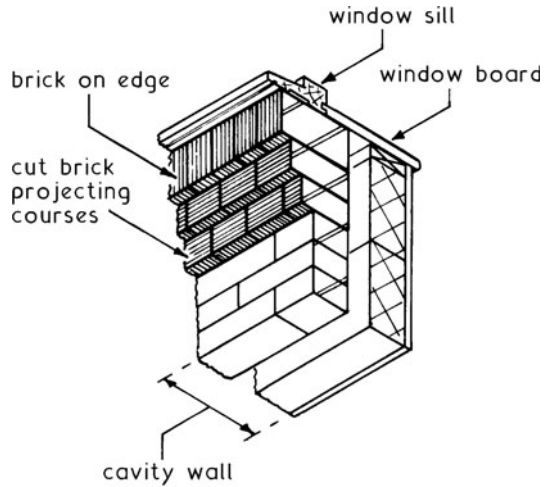

Corbelled sill

Dentil Coursing - a variation on continuous corbelling where alternate headers project. This is sometimes referred to as table corbelling.

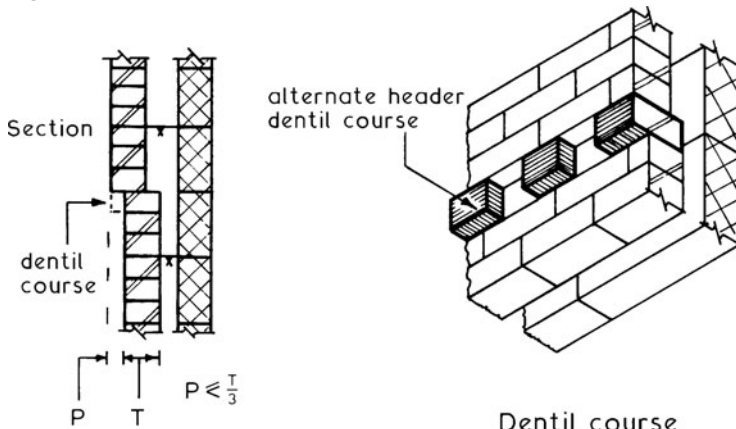

Dentil course

Dog Tothing - a variation on a dentil course created by setting the feature bricks at 45°.

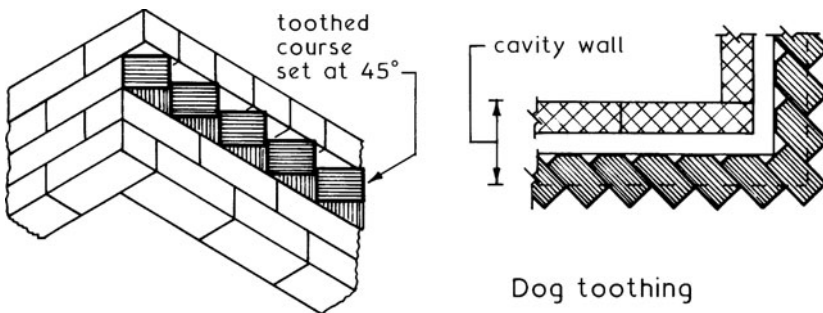

Dog tothing

NB. Cavity insulated as required.

Blocks ~ these are walling units exceeding in length, width or height the dimensions specified for bricks in BS EN 772-16. Precast concrete blocks should comply with the recommendations set out in BS 6073-2 and BS EN 771-3. Blocks suitable for external solid walls are classified as load bearing and are required to have a minimum declared compressive strength of not less than 2.9 N/mm<sup>2</sup>.

Typical Details ~

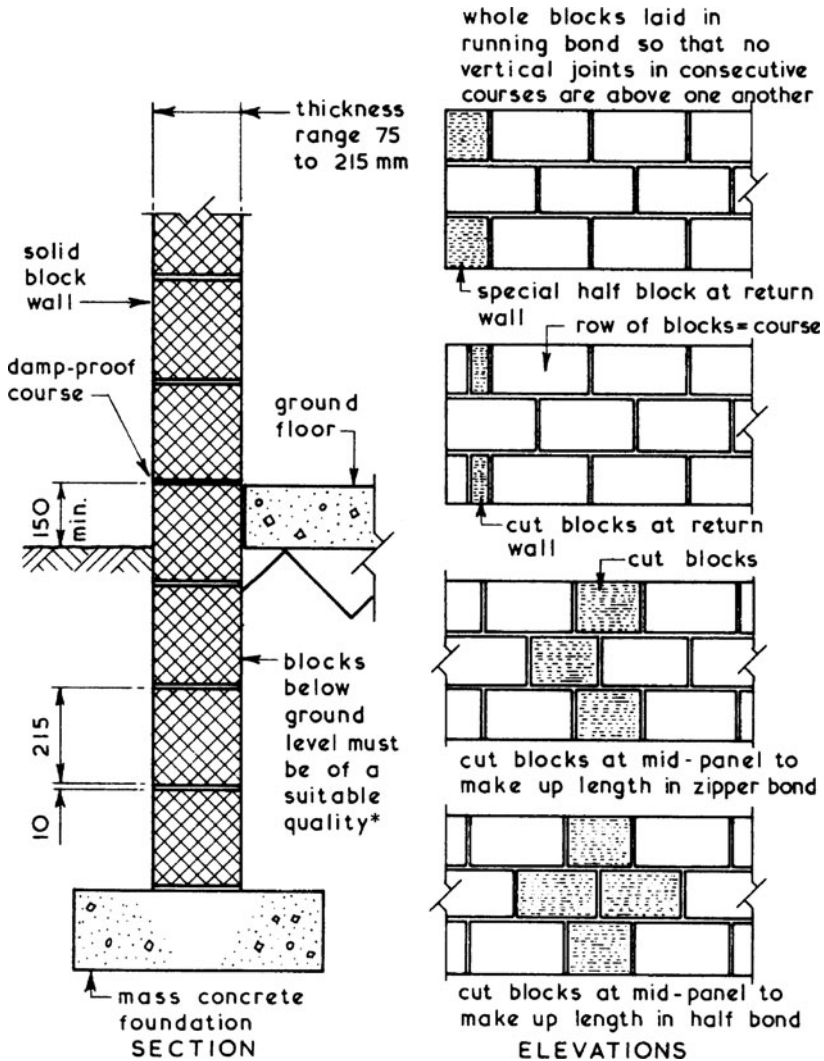

\*See pages 401 to 403.

Refs.: BS 6073-2: Precast concrete masonry units.

BS EN 772-16: Methods of test for masonry units.

BS EN 771-3: Specification for (concrete) masonry units.

## Cavity Walls

Cavity Walls ~ these consist of an outer brick or block leaf or skin separated from an inner brick or block leaf or skin by an air space called a cavity. These walls have better thermal insulation and weather-resistance properties than a comparable solid brick or block wall and therefore are in general use for the enclosing walls of domestic buildings. The two leaves of a cavity wall are tied together with wall ties located at  $2.5/m^2$ , or at equivalent spacings shown below and as given in Section 2C of Approved Document A - Building Regulations.

With butterfly-type ties the width of the cavity should be between 50 and 75 mm. Where vertical twist-type ties are used the cavity width can be between 75 and 300 mm. Cavities are not normally ventilated and are closed by roof insulation at eaves level.

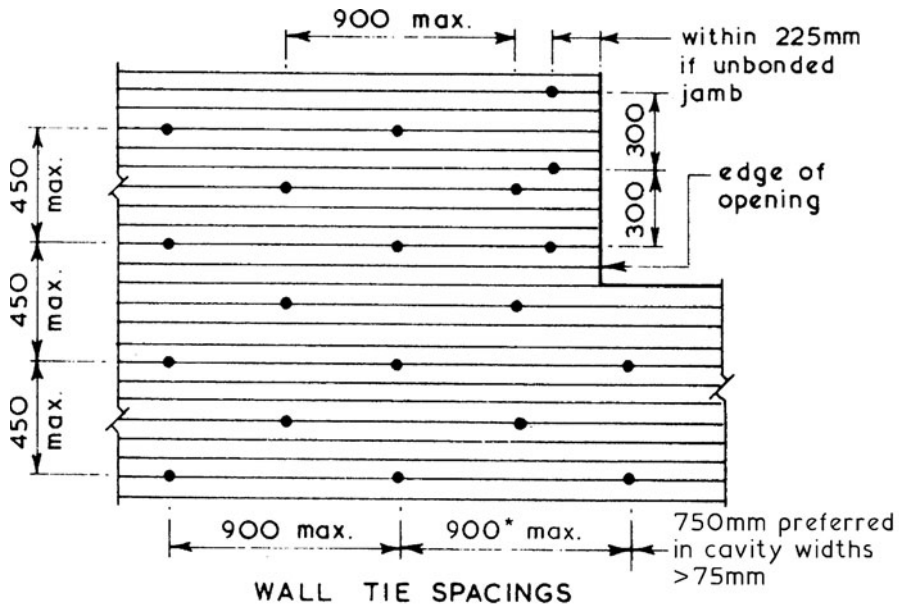

200 to 425 x 20 x 3 to 4.8mm galvanised\* vertical twist-type wall tie embedded at least 50mm

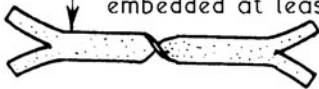

200 x 3.15mm diameter galvanised\* butterfly-type wall tie

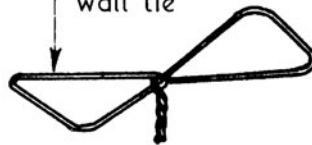

### TYPICAL METAL WALL TIES

Ref: BS EN 845-1: Specification for ancillary components for masonry. Wall ties, tension straps, hangers and brackets.

\* Stainless steel or non-ferrous ties are now preferred.

Minimum requirements ~

Thickness of each leaf, 90 mm.

Width of cavity, 50 mm.

Wall ties at  $2.5/m^2$  (see previous page).

Compressive strength of bricks,  $6 N/mm^2$  up to two storeys.\*

Compressive strength of blocks,  $2.9 N/mm^2$  up to two storeys.\*

\* For work between the foundation and the surface a  $6 N/mm^2$  minimum brick strength is normally specified or  $2.9 N/mm^2$  minimum concrete block strength (see next page for variations).

Combined thickness of each leaf + 10 mm whether used as an external wall, a separating wall or a compartment wall, should be not less than  $1/16$  of the storey height\*\* which contains the wall.

\*\* Generally measured between the undersides of lateral supports, e.g. undersides of floor or ceiling joists, or from the underside of upper floor joists to half-way up a laterally restrained gable wall. See Approved Document A, Section 2C for variations and next page.

Wall dimensions for minimum combined leaf thicknesses of 90 mm + 90 mm + 10 mm (190 mm min. actual thickness) ~

Height	Length
3.5 m max.	12.0 m max.
3.5 m – 9.0 m	9.0 m max.

Wall dimensions for minimum combined leaf thickness of 280 mm + 10 mm (290 mm actual thickness), e.g. 190 mm + 100 mm for one storey height and a minimum 180 mm combined leaf thickness + 10 mm (i.e. 90 mm + 100 mm) for the remainder of its height ~

Height	Length
3.5 – 9.0 m	9.0 – 12.0 m
9.0 m – 12.0 m	9.0 m max.

Wall dimensions for minimum combined leaf thickness of 280 mm + 10 mm (290 mm actual thickness) for two-storey height and a minimum 180 mm combined leaf thickness + 10 mm (190 mm actual thickness) for the remainder of its height ~

Height	Length
9.0 m – 12.0 m	9.0 m – 12.0 m

Wall length is measured from centre to centre of restraints by buttress walls, piers or chimneys.

For other wall applications, see the reference to calculated brickwork on page 419.

# Cavity Walls

Single storey

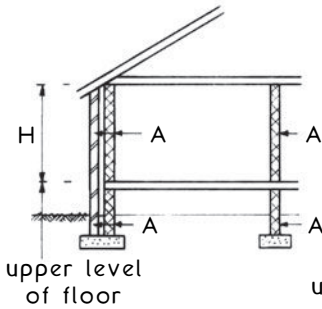

Two storeys

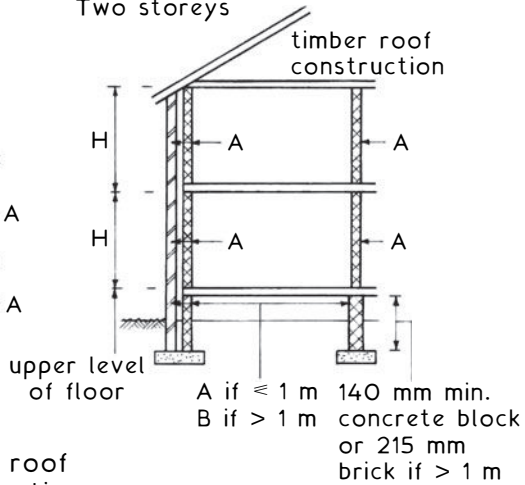

Three storeys

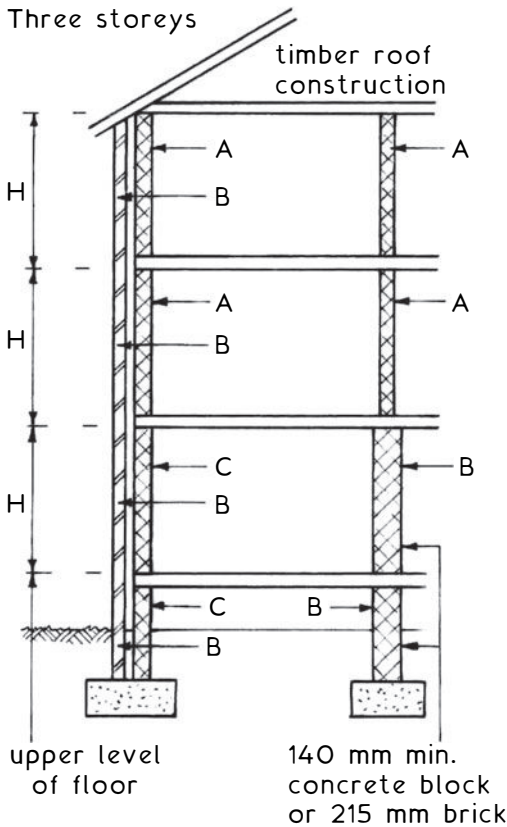

Key for  $H \leq 2.7$  m ( $N/mm^2$  min. compressive strength) ~

	Conc.blocks	Bricks
A	2.9	6.0
B	7.3	9.0
C	7.3	18.0

Note 1: If  $H > 2.7$  m, A should be at least  $7.3 N/mm^2$  for concrete blocks and  $9 N/mm^2$  for brickwork, or as indicated in the diagrams (take greater value).

Note 2: The above applies to standard format bricks of  $215 \text{ mm} \times 102.5 \text{ mm} \times 65 \text{ mm}$  with  $< 25\%$  formed voids ( $20\%$  for bricks with frogs). For bricks with voids  $> 25\%$  (max.  $55\%$ ) see Table 6 in Approved Document A, Section 2C.

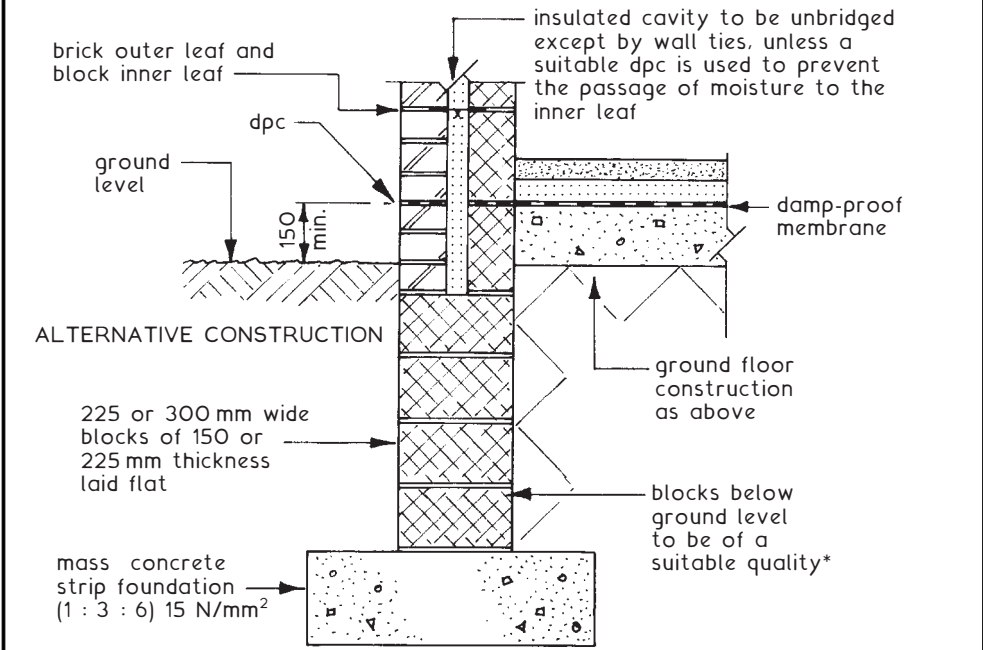
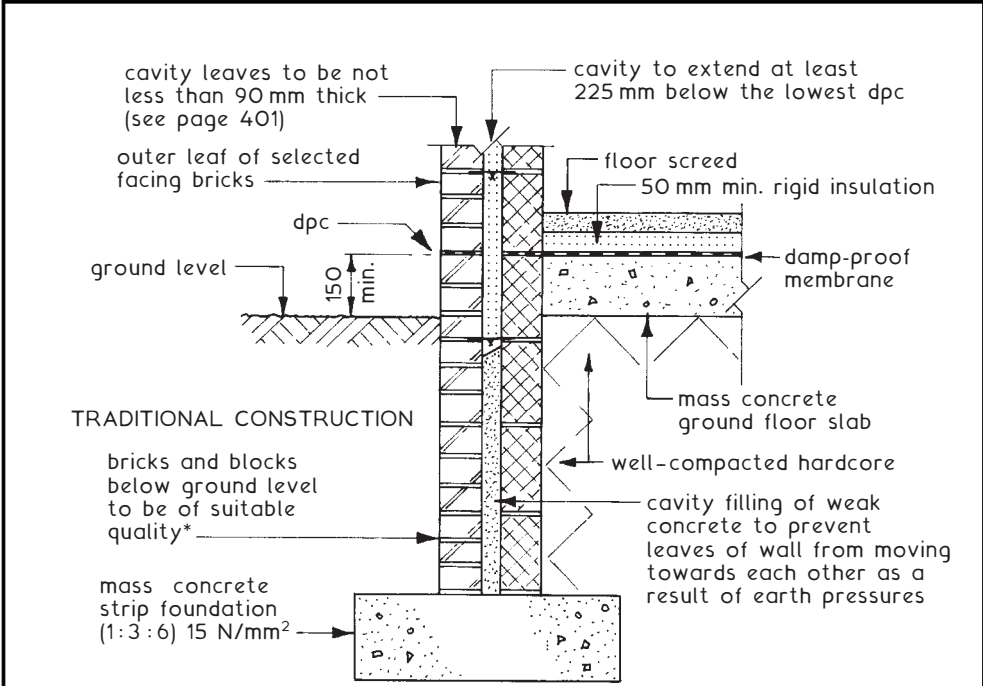

\*Min. compressive strength depends on building height and loading. See Building Regulations A.D. A: Section 2C (Diagram 9) and extracts shown on the previous page.



# Parapet Walls

Parapet ~ a low wall projecting above the level of a roof, bridge or balcony forming a guard or barrier at the edge. Parapets are exposed to the elements, justifying careful design and construction for durability.

Typical Details ~

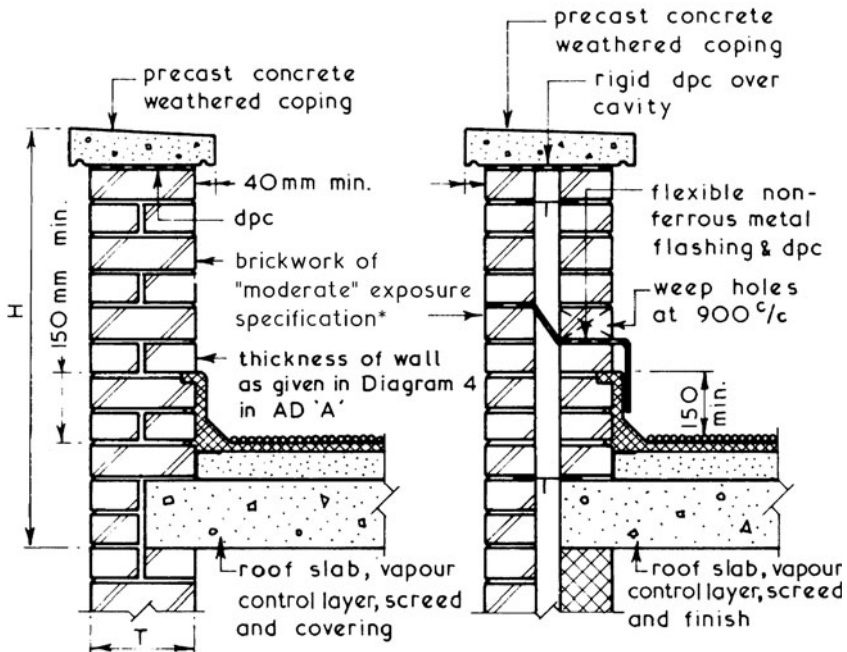

T (1 bk. solid and 1/2 bk. cavity wall). H ≥ 860mm.

SOLID WALL- HIGH LEVEL

CAVITY WALL- HIGH LEVEL

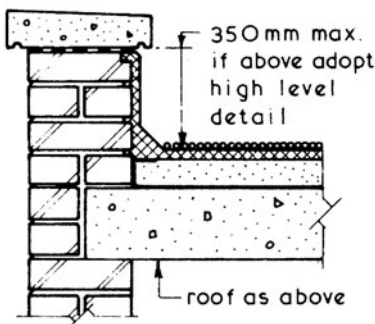

SOLID WALL- LOW LEVEL

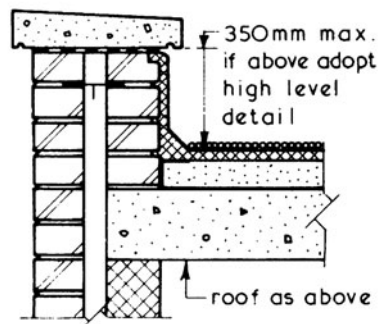

CAVITY WALL- LOW LEVEL

Ref. BS EN 771-1: Specification for (clay) masonry units.

\*`severe` exposure specification in the absence of a protective coping.

Historically, finned or buttressed walls have been used to provide lateral support to tall, single storey masonry structures such as churches and cathedrals. Modern applications are similar in principle and include theatres, gymnasiums, warehouses, etc. Where space permits, they are an economic alternative to masonry cladding of steel or reinforced concrete framed buildings. The fin or pier is preferably brick bonded to the main wall. It may also be connected with horizontally bedded wall ties, sufficient to resist vertical shear stresses between fin and wall.

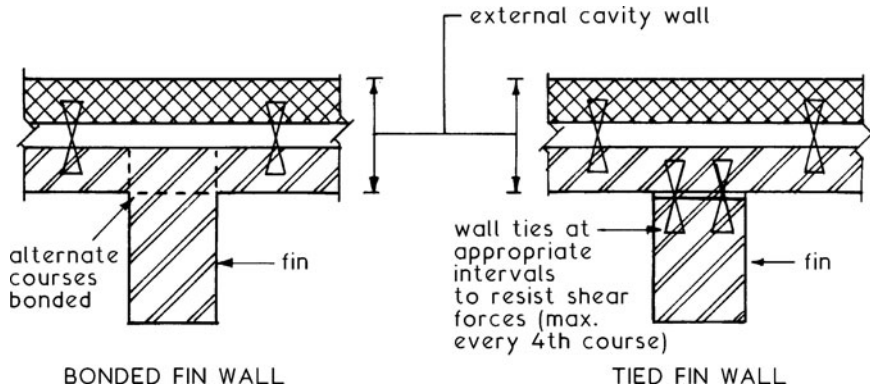

Structurally, the fins are deep piers which reinforce solid or cavity masonry walls. For design purposes the wall may be considered as a series of 'T' sections composed of a flange and a pier. If the wall is of cavity construction, the inner leaf is not considered for bending moment calculations, although it does provide stiffening to the outer leaf or flange.

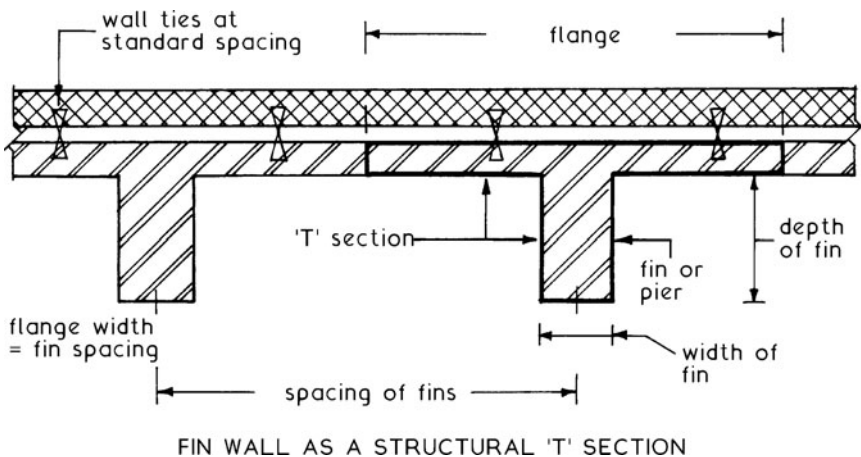

## Masonry Diaphragm Walls

Masonry diaphragm walls are an alternative means of constructing tall, single storey buildings such as warehouses, sports centres, churches, assembly halls, etc. They can also be used as retaining and boundary walls with planting potential within the voids. These voids may also be steel reinforced and concrete filled to resist the lateral stresses in high retaining walls.

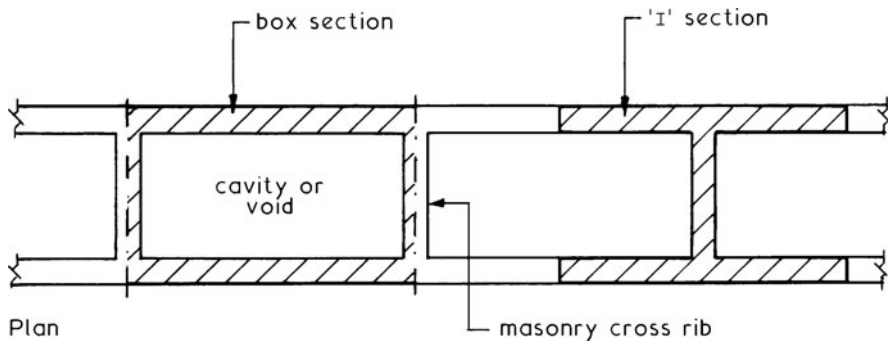

A diaphragm wall is effectively a cavity wall where the two leaves of masonry are bonded together with cross ribs and not wall ties. It is stronger than a conventionally tied cavity wall and for structural purposes may be considered as a series of bonded 'I' sections or box sections. The voids may be useful for housing services, but any access holes in the construction must not disturb the integrity of the wall. The voids may also be filled with insulation to reduce heat energy losses from the building, and to prevent air circulatory heat losses within the voids. Where thermal insulation standards apply, this type of wall will have limitations as the cross ribs will provide a route for cold bridging. U-values will increase by about 10% compared with conventional cavity wall construction of the same materials.

Ref. BS EN 1996: Design of masonry structures.

PD 6697: Recommendations for the design of masonry structures.

Individual masonry units may not be uniform in dimensions and shape. This characteristic is particularly applicable to natural stone masonry and to kiln manufactured clay bricks. Dimensional variations and other irregularities must be accommodated within an area of walling. The following is acceptable:

## Vertical Alignment and Straightness ~

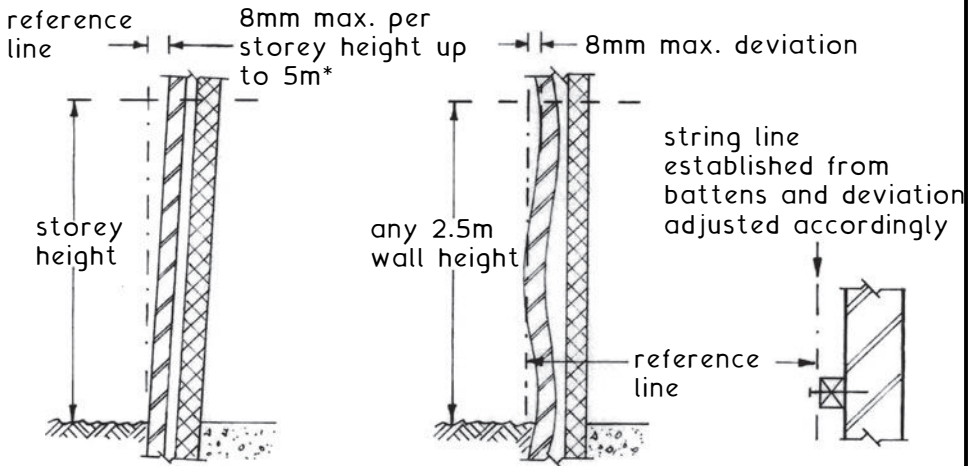

\*Walls > 5m height, max. 12mm out of plumb. Limited to 8mm/storey height. E.g. typical storey height of 2.5m = 3.2mm/m.

## Horizontal Alignment ~

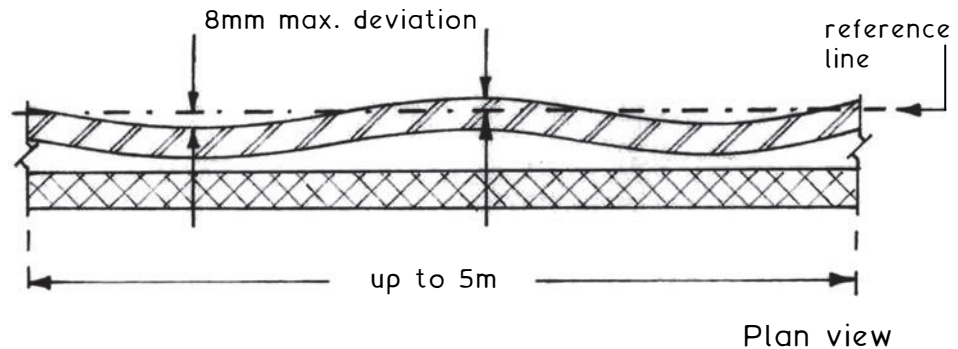

# Damp-proof Courses and Membranes

Function - the primary function of any damp-proof course (dpc) or damp-proof membrane (dpm) is to provide an impermeable barrier to the passage of moisture. The three basic ways in which damp-proof courses are used is to:

1. Resist moisture penetration from below (rising damp).
2. Resist moisture penetration from above.
3. Resist moisture penetration from horizontal entry.

## Typical Examples ~

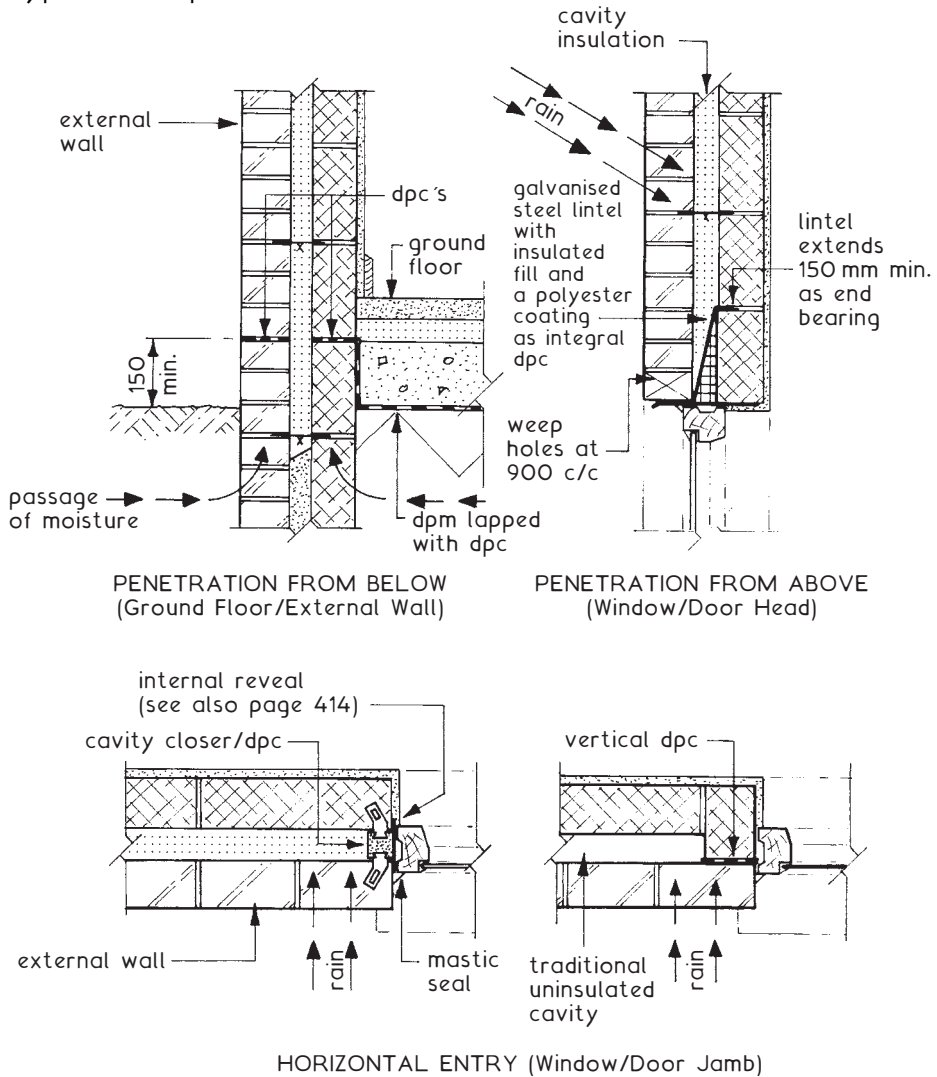

See also: BSs 743, 6398, 6515, 8102 and 8215.

## Materials for Damp-proof Courses (1)

Building Regulations, Approved Document C2, Section 5:

A wall may be built with a 'damp-proof course of bituminous material, polyethylene, engineering bricks or slates in cement mortar, or any other material that will prevent the passage of moisture.'

Material	Remarks
Lead      BS EN 12588      Code 4 (1.8 mm)	May corrode in the presence of mortar. Both surfaces to be coated with bituminous paint. Workable for application to cavity trays, etc.
Copper    BS EN 1172      0.25 mm	Can cause staining to adjacent masonry. Resistant to corrosion.
Bitumen    BS 6398 in various bases:	Hessian or fibre may decay with age, but this will not affect efficiency.
Hessian                      3.8 kg/m <sup>2</sup>	Tearable if not
Fibre                        3.3 ...	protected. Lead bases
Asbestos                    3.8 ...	are suited where there
Hessian & lead            4.4 ...	may be a high degree of
Fibre & lead                4.4 ...	movement in the wall. Asbestos is now prohibited.
LDPE      BS 6515 (polyethylene)              0.46 mm	No deterioration likely, but may be difficult to bond, hence the profiled surface finish. Not suited under light loads.
Bitumen polymer and pitch polymer            1.10 mm	Absorbs movement well. Joints and angles made with product manufacturer's adhesive tape.
Polypropylene BS 5139 1.5 to 2.0 mm	Preformed dpc for cavity trays, cloaks, direction changes and over lintels.

NB. All the above dpcs to be lapped at least 100mm at joints and adhesive sealed. Dpcs should be continuous with any dpm in the floor.

## Materials for Damp-proof Courses (2)

Material			Remarks
Mastic asphalt	BS 6925	12kg/m <sup>2</sup>	Does not deteriorate. Requires surface treatment with sand or scoring to effect a mortar key.
Engineering bricks	BS EN 771-1 BS EN 772-7	<4.5% absorption	Min. two courses laid breaking joint in cement mortar 1:3. No deterioration, but may not blend with adjacent facings.
Slate	BS EN 12326-1	4 mm	Min. two courses laid as above. Will not deteriorate, but brittle so may fracture if building settles.

Refs.:

BS 743: Specification for materials for damp-proof courses.

BS 8102: Code of practice for protection of structures against water from the ground.

BS 8215: Code of practice for design and installation of damp-proof courses in masonry construction.

BRE Digest 380: Damp-proof courses.

Note: It was not until the Public Health Act of 1875, that it became mandatory to install damp-proof courses in new buildings. Structures constructed before that time, and those since, which have suffered dpc failure due to deterioration or incorrect installation, will require remedial treatment. This could involve cutting out the mortar bed-joint two brick courses above ground level in stages of about 1m in length. A new dpc can then be inserted with mortar packing, before proceeding to the next length. No two adjacent sections should be worked consecutively. This process is very time consuming and may lead to some structural settlement. Therefore, the measures explained on the following two pages are usually preferred.

## Chemical Damp-proof Courses for Remedial Work (1)

Materials – Silicone solutions in organic solvent.

Aluminium stearate solutions.

Water-soluble silicone formulations (siliconates).

Methods – High pressure injection (0.70–0.90 MPa) solvent based.

Low pressure injection (0.15–0.30 MPa) water based.

Gravity feed, water based.

Insertion/injection, mortar based.

Pressure injection – 12mm diameter holes are bored to about two-thirds the depth of masonry, at approximately 150mm horizontal intervals at the appropriate depth above ground (normally two to three brick courses). These holes can incline slightly downwards. With high (low) pressure injection, walls in excess of 120mm (460 mm) thickness should be drilled from both sides. The chemical solution is injected by pressure pump until it exudes from the masonry. Cavity walls are treated as each leaf being a solid wall.

Gravity feed – 25mm diameter holes are bored as above. Dilute chemical is transfused from containers which feed tubes inserted in the holes. This process can take from a few hours to several days to effect. An alternative application is insertion of frozen pellets placed in the boreholes. On melting, the solution disperses into the masonry to be replaced with further pellets until the wall is saturated.

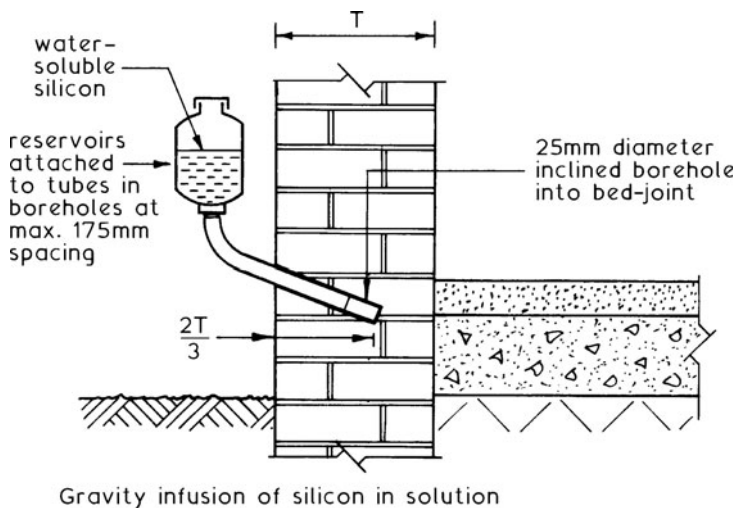



## Chemical Damp-proof Courses for Remedial Work (2)

Injection mortars – 19 mm diameter holes are bored from both sides of a wall, at the appropriate level and no more than 230 mm apart horizontally, to a depth equating to three-fifths of the wall thickness. They should be inclined downwards at an angle of 20 to 30°. The drill holes are flushed out with water, before injecting mortar from the base of the hole and outwards. This can be undertaken with a hand operated caulking gun. Special cement mortars contain styrene butadiene resin (SDR) or epoxy resin and must be mixed in accordance with the manufacturer's guidance.

Notes relating to all applications of chemical dpcs:

- \* Before commencing work, old plasterwork and rendered undercoats are removed to expose the masonry. This should be to a height of at least 300 mm above the last detectable (moisture meter reading) signs of rising dampness (1 metre min.).
- \* If the wall is only accessible from one side and both sides need treatment, a second deeper series of holes may be bored from one side, to penetrate the inaccessible side.
- \* On completion of work, all boreholes are made good with cement mortar. Where dilute chemicals are used for the dpc, the mortar is rammed the full length of the hole with a piece of timber dowelling.
- \* The chemicals are effective by bonding to, and lining the masonry pores by curing and solvent evaporation.
- \* The process is intended to provide an acceptable measure of control over rising dampness. A limited amount of water vapour may still rise, but this should be dispersed by evaporation in a heated building.

Refs.:

- BS 6576: Code of practice for diagnosis of rising damp in walls of buildings and installation of chemical damp-proof courses.
- BRE Digest 245: Rising damp in walls: diagnosis and treatment.
- BRE Digest 380: Damp-proof courses.
- BRE Good Repair Guide 6: Treating rising damp in houses.

## Bridging of Damp-proof Courses

In addition to damp-proof courses failing due to deterioration or damage, they may be bridged as a result of:

- \* Faults occurring during construction.
- \* Work undertaken after construction, with disregard for the damp-proof course.

Typical Examples ~

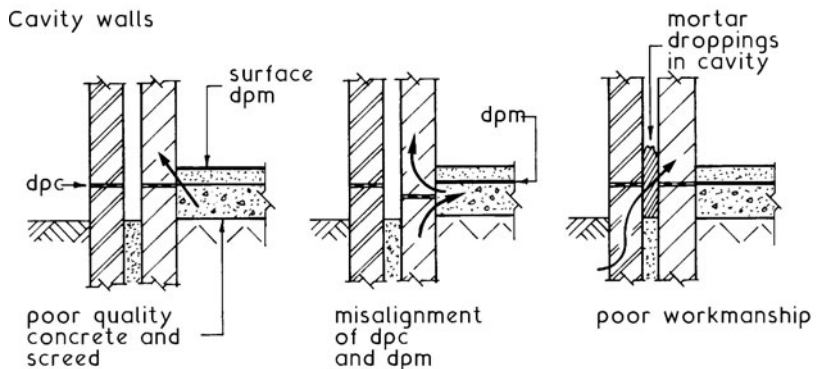
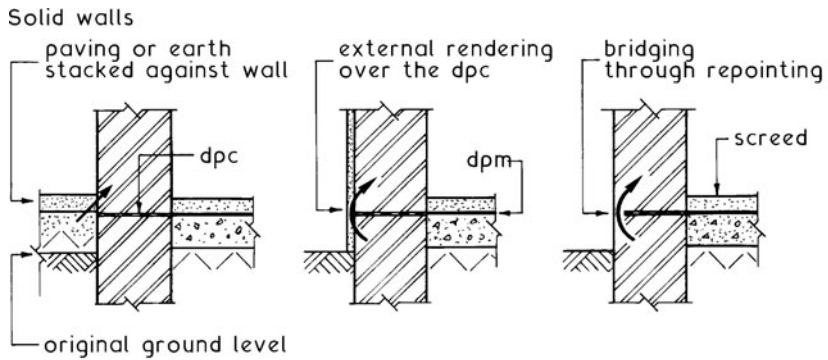

## Insulating Damp-proof Course

Thermal insulation regulations may require insulating dpcs to prevent cold bridging around window and door openings in cavity wall construction (see pages 580 and 581). By locating a vertical dpc with a bonded insulant at the cavity closure, the dpc prevents penetration of dampness from the outside, and the insulation retains the structural temperature of the internal reveal. This will reduce heat losses by maintaining the temperature above dewpoint, preventing condensation, wall staining and mould growth.

Application ~

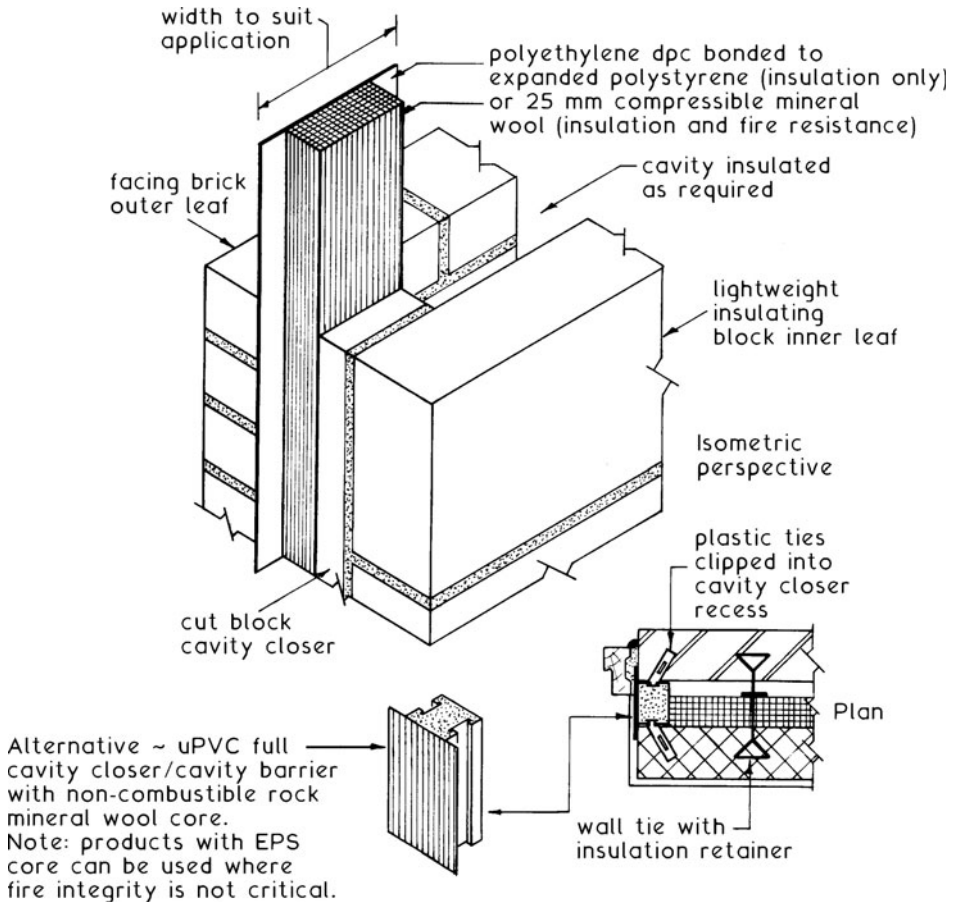

Refs.: Building Regulations, Approved Document L: Conservation of fuel and power.

BRE Report - Thermal Insulation: avoiding risks (3rd. ed.).

Building Regulations, Approved Document B3 (Vol. 1), Section 6: Concealed spaces (cavities).

### Penetrating Gases ~ Methane and Radon

Methane – methane is produced by deposited organic material decaying in the ground. It often occurs with carbon dioxide and traces of other gases to form a cocktail known as landfill gas. It has become an acute problem in recent years, as planning restrictions on 'green-field' sites have forced development of derelict and reclaimed 'brown-field' land.

The gas would normally escape into the atmosphere, but under a building it pressurises until percolating through cracks, cavities and junctions with services. Being odourless, it is not easily detected until contacting a naked flame, then the result is devastating!

Radon ~ a naturally occurring colour/odourless gas produced by radioactive decay of radium. It originates in uranium deposits of granite subsoils as far apart as the south-west and north of England and the Grampian region of Scotland. Concentrations of radon are considerably increased if the building is constructed of granite masonry. The combination of radon gas and the tiny radioactive particles known as radon daughters are inhaled. In some people with several years' exposure, research indicates a high correlation with cancer related illness and death.

Protection of buildings and the occupants from subterranean gases can be achieved by passive or active measures incorporated within the structure:

1. Passive protection consists of a complete airtight seal integrated within the ground floor and walls. A standard LDPE damp-proof membrane of 0.3mm thickness should be adequate if carefully sealed at joints, but thicknesses of up to 1mm are preferred, combined with foil and/or wire reinforcement.
2. Active protection requires installation of a permanently running extract fan connected to a gas sump below the ground floor. It is an integral part of the building services system and will incur operating and maintenance costs throughout the building's life.

NB. See next page for construction details.

# Gas-resistant Construction

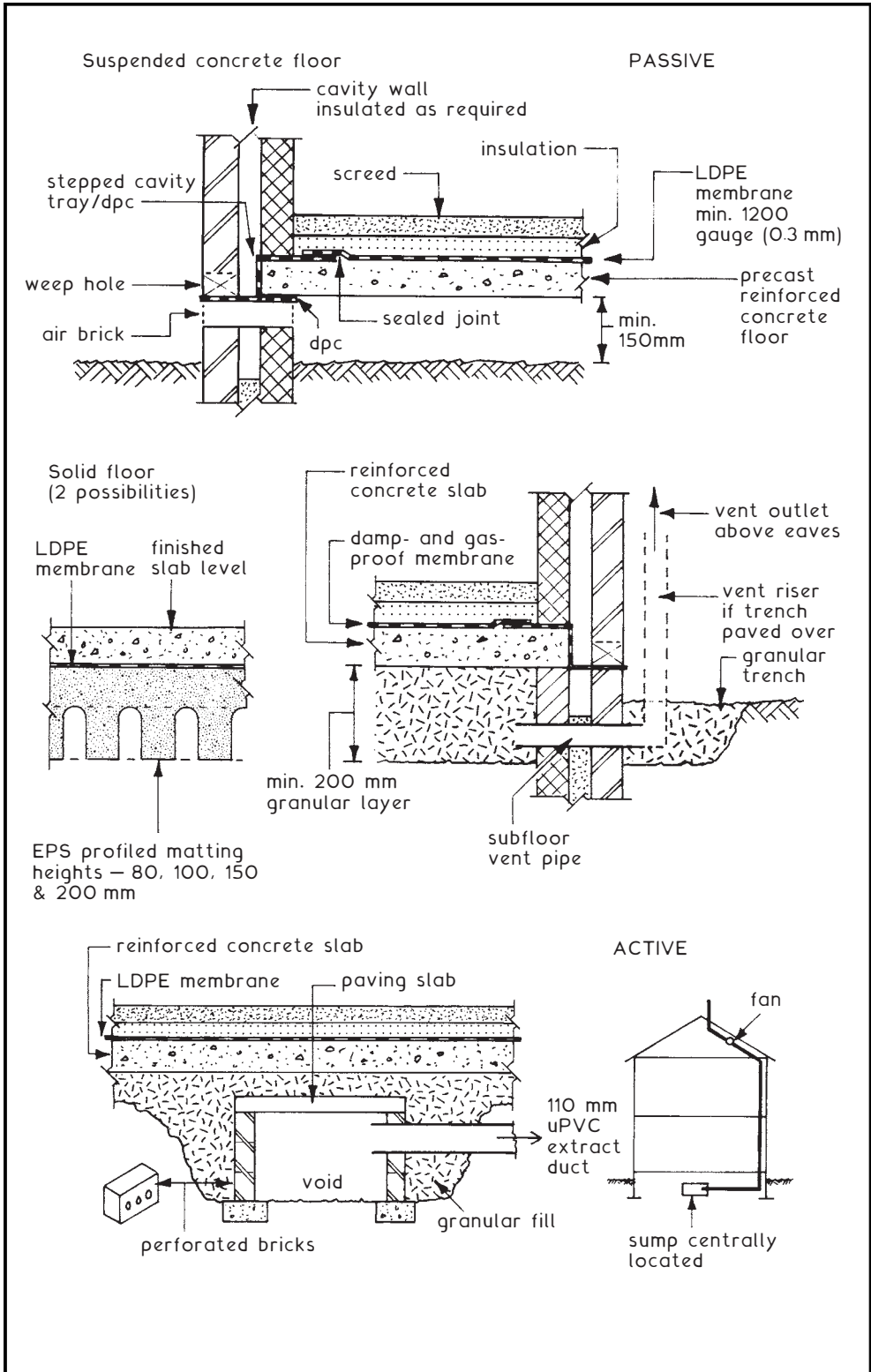

Calculated Brickwork ~ for small and residential buildings up to three storeys high the sizing of load bearing brick walls can be taken from data given in Section 2C of Approved Document A. The alternative methods for these and other load bearing brick walls are given in:

BS EN 1996: Design of masonry structures.

BS 8103-2: Structural design of low rise buildings. Code of practice for masonry walls for housing.

The main factors governing the load bearing capacity of brick walls and columns are:

1. Thickness of Wall.
2. Strength of bricks used.
3. Type of mortar used.
4. Slenderness ratio of wall or column.
5. Eccentricity of applied load.

Thickness of Wall ~ this must always be sufficient throughout its entire body to carry the design loads and induced stresses. Other design requirements such as thermal and sound insulation properties must also be taken into account when determining the actual wall thickness to be used.

Effective Thickness ~ this is the assumed thickness of the wall or column used for the purpose of calculating its slenderness ratio - see page 419.

Typical Examples ~

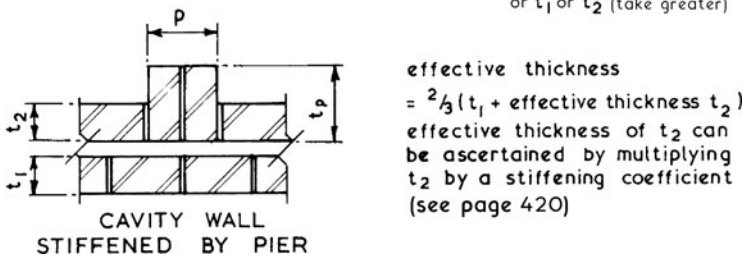
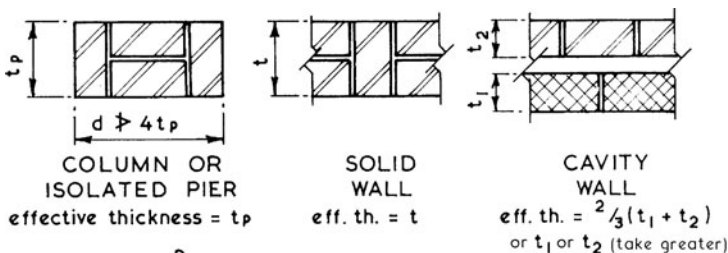

## Principles of Calculated Brickwork – Strength

Strength of Bricks ~ due to the wide variation of the raw materials and methods of manufacture bricks can vary greatly in their compressive strength. The compressive strength of a particular type of brick or batch of bricks is taken as the arithmetic mean of a sample of ten bricks tested in accordance with the appropriate British Standard. A typical range for clay bricks would be from 20 to 170 MN/m<sup>2</sup> the majority of which would be in the 20 to 90 MN/m<sup>2</sup> band. Calcium silicate bricks have a compressive strength between 20 and 50 MN/m<sup>2</sup>.

Strength of Mortars ~ mortars consist of an aggregate (sand) and a binder which is usually cement; cement plus additives to improve workability; or cement and lime. The factors controlling the strength of any particular mix are the ratio of binder to aggregate plus the water:cement ratio. The strength of any particular mix can be ascertained by taking the arithmetic mean of a series of test cubes or prisms – see page 423.

Wall Design Strength ~ the basic stress of any brickwork depends on the crushing strength of the bricks and the type of mortar used to form the wall unit. This relationship can be plotted on a graph as shown below:

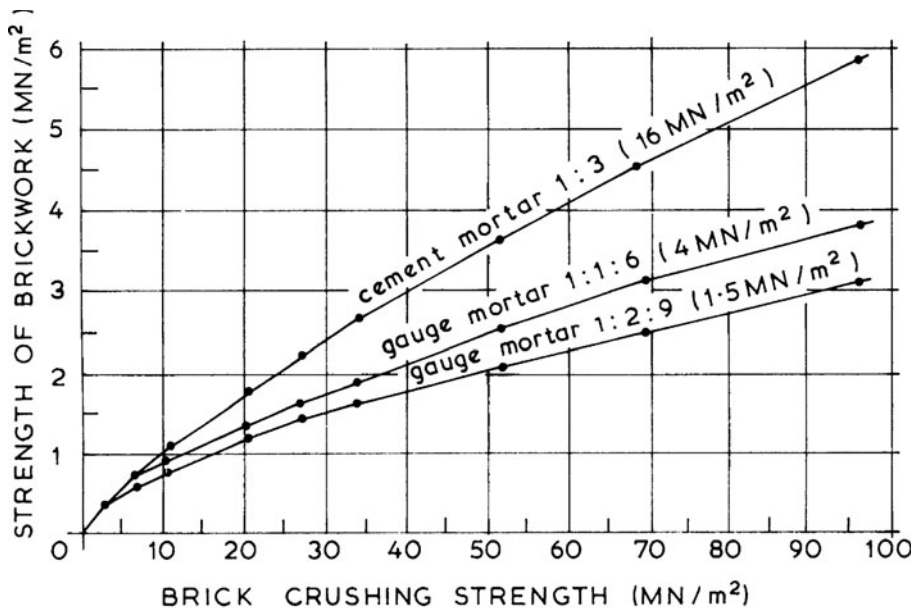

NB. 1 MN/m<sup>2</sup> equates to 1 N/mm<sup>2</sup>.

# Principles of Calculated Brickwork – Slenderness Ratio

Slenderness Ratio ~ this is the relationship of the effective height to the effective thickness thus:

$$\text{Slenderness ratio} = \frac{\text{effective height}}{\text{effective thickness}} = \frac{h}{t} \geq 27$$

Effective Height ~ this is the dimension taken to calculate the slenderness ratio as opposed to the actual height.

Typical Examples - actual height = H effective height = h

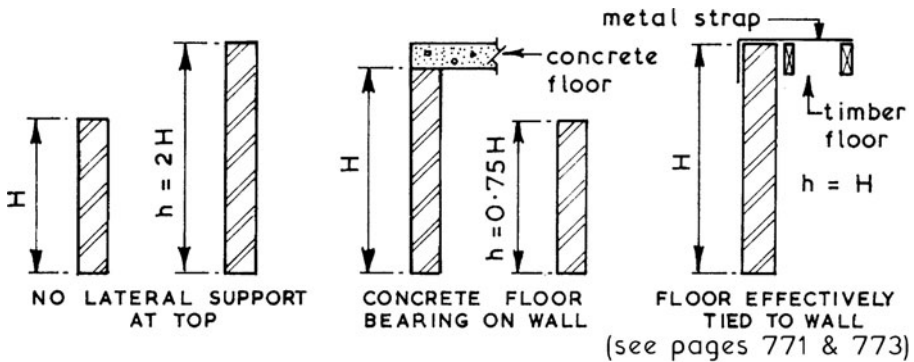

Effective Thickness ~ this is the dimension taken to calculate the slenderness ratio as opposed to the actual thickness.

Typical Examples - actual thickness = T effective thickness = t

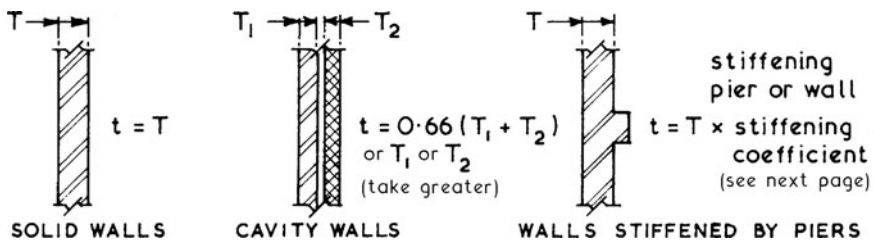

Stress Reduction ~ the permissible stress for a wall is based on the basic stress multiplied by a reduction factor related to the slenderness factor and the eccentricity of the load:

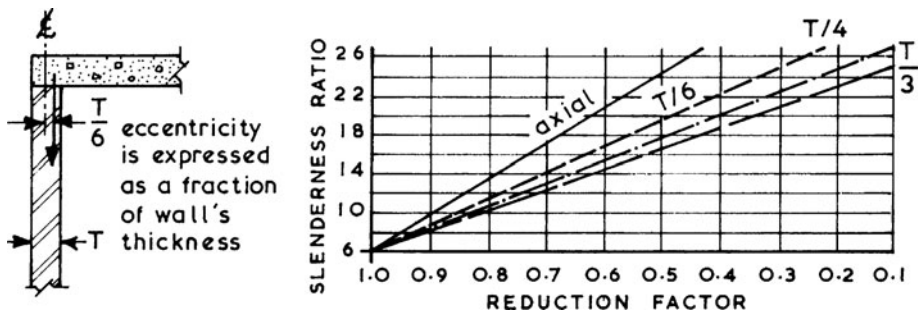



# Principles of Calculated Brickwork – Piers

Piers, Effective Thickness ~

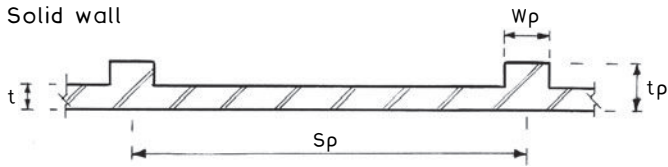

Effective Thickness =  $tK$

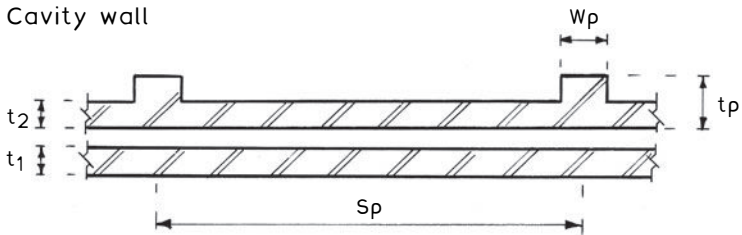

Effective Thickness =  $0.66 (t_1 + t_2K)$  or  $t_1$  or  $t_2K$  (take greater)

- Key:
- $t$  = actual wall thickness
  - $t_1$  = actual thickness of cavity leaf without attached pier
  - $t_2$  = actual thickness of leaf with attached pier
  - $t_p$  = pier thickness
  - $K$  = stiffening coefficient
  - $S_p$  = pier spacing
  - $W_p$  = pier width

Stiffening Coefficient  $K$  ~

$S_p \div W_p$	$t_p \div t = 1$	2	3
$\leq 6$	$K = 1.0$	1.4	2.0
10	1.0	1.2	1.4
$\geq 20$	1.0	1.0	1.0

Linear interpolation may be applied

E.g.

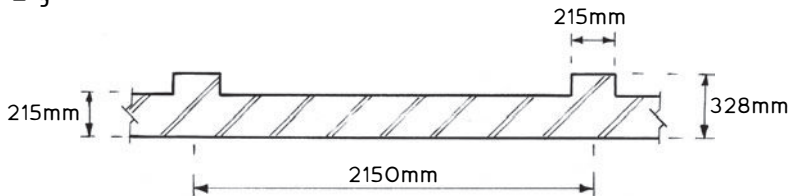

$$S_p \div W_p = 2150 \div 215 = 10$$

$$t_p \div t = 328 \div 215 = 1.523$$

By interpolation,  $K = 1.104$

$$\text{Effective thickness, } tK = 215 \times 1.104 = 237.4 \text{ mm}$$

Piers and Columns, Effective Height Calculations ~

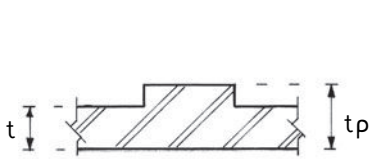

$tp \leq 1.5t$  design  
as a pier

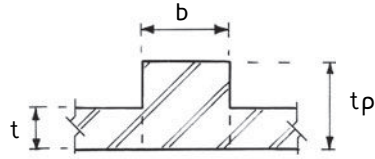

$tp > 1.5t$  design as a column  
effective thickness =  $tp$  or  $b$   
depending on direction of bending

E.g. A one-and-a-half brick column of 4.000m effective height/length. See page 645 for factors affecting the effective length of a column.

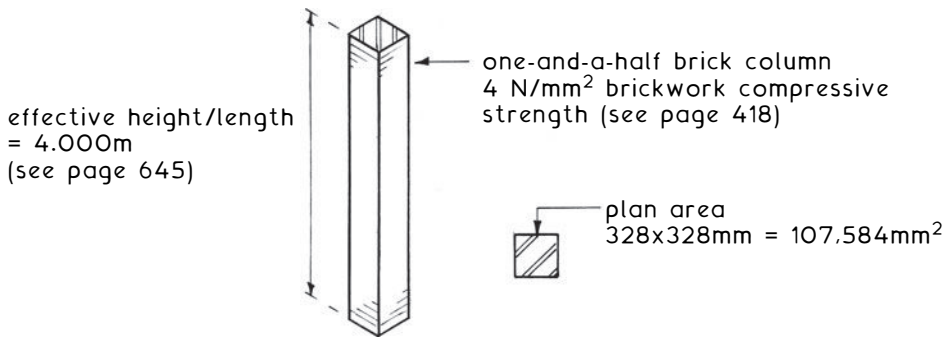

It is usual to incorporate a factor of safety into these calculations. Using a figure of 2, the brickwork safe bearing strength will be:

$$4 \text{ N/mm}^2 \div 2 = 2 \text{ N/mm}^2$$

Permissible load will be:

$$2 \text{ N/mm}^2 \times 107.584 = 215.168 \text{ Newtons}$$

$$\text{Newtons} \div \text{gravity } (9.81 \text{ m/s}^2) = \text{kilograms}$$

$$215.168 \div 9.81 = 21.933\text{kg} \text{ (22 tonnes approx.)}$$

Note: This example is a very simple application that has assumed that there is no axial loading with bending or eccentric forces such as lateral loading from the structure or from wind loading. It also has a low slenderness ratio (effective height/length to least lateral dimension), i.e.  $4000 \text{ mm} \div 328 \text{ mm} = 12.2$ . See pages 602 and 603 for the effect of buckling factors where greater slenderness ratios apply.

## Mortars for Brickwork and Blockwork (1)

Lime ~ traditional mortars are a combination of lime, sand and water. These mixes are very workable and have sufficient flexibility to accommodate a limited amount of wall movement due to settlement, expansion and contraction. The long term durability of lime mortars is poor as they can break down in the presence of atmospheric contaminants and surface growths. Nevertheless, lime is frequently specified as a supplementary binder with cement, to increase mix workability and to reduce the possibility of joint shrinkage and cracking, a characteristic of stronger cement mortars.

Cement ~ the history of cement-type mortar products is extensive. Examples dating back to the Mesopotamians and the Egyptians are not unusual; one of the earliest examples from over 10,000 years ago has been found in Galilee, Israel. Modern mortars are made with Portland cement, the name attributed to a bricklayer named Joseph Aspdin. In 1824 he patented his improved hydraulic lime product as Portland cement, as it resembled Portland stone in appearance. It was not until the 1920s that Portland cement, as we now know it, was first produced commercially by mixing a slurry of clay (silica, alumina and iron-oxides) with limestone (calcium carbonate). The mix is burnt in a furnace (calcinated) and the resulting clinker crushed and bagged.

Mortar ~ mixes for masonry should have the following properties:

- \* Adequate strength
- \* Workability
- \* Water retention during laying
- \* Plasticity during application
- \* Adhesion or bond
- \* Durability
- \* Good appearance ~ texture and colour

Modern mortars are a combination of cement, lime and sand plus water. Liquid plasticisers exist as a substitute for lime, to improve workability and to provide some resistance to frost when used during winter.

Masonry cement ~ these proprietary cements generally contain about 75% Portland cement and about 25% of fine limestone filler with an air entraining plasticiser. Allowance must be made when specifying the mortar constituents to allow for the reduced cement content. These cements are not suitable for concrete.

Refs.: BS 6463-101, 102 and 103: Quicklime, hydrated lime and natural calcium carbonate.

BS EN 197-1: Cement. Composition, specifications and conformity criteria for common cements.

Ready mixed mortar ~ this is delivered dry for storage in purpose-made silos with integral mixers as an alternative to site blending and mixing. This ensures:

- \* Guaranteed factory quality controlled product
- \* Convenience
- \* Mix consistency between batches
- \* Convenient facility for satisfying variable demand
- \* Limited wastage
- \* Optimum use of site space

Mortar and cement strength ~ see also page 418. Test samples are made in prisms of 40×40 mm cross section, 160mm long. At 28 days samples are broken in half to test for flexural strength. The broken pieces are subject to a compression test across the 40 mm width. An approximate comparison between mortar strength (MN/m<sup>2</sup> or N/mm<sup>2</sup>), mortar designations (i to v) and proportional mix ratios is shown in the classification table below. Included is guidance on application.

Proportional mixing of mortar constituents by volume is otherwise known as a prescribed mix or simply a recipe.

Mortar classification ~

Traditional designation	BS EN 998-2 Strength	Proportions by volume		Application
		cement/lime/sand	cement/sand	
i	12	1:0.25:3	1:3	Exposed external
ii	6	1:0.5:4-4.5	1:3-4	General external
iii	4	1:1:5-6	1:5-6	Sheltered internal
iv	2	1:2:8-9	1:7-8	General internal
v	-	1:3:10-12	1:9-10	Internal, grouting

Relevant standards:

BS EN 1996: Design of masonry structures.

BS EN 196: Methods of testing cement.

BS EN 998-2: Specification for mortar for masonry. Masonry mortar.

PD 6678: Guide to the specification of masonry mortar.

BS EN 1015: Methods of test for mortar for masonry.

# Supports Over Openings

Supports Over Openings ~ the primary function of any support over an opening is to carry the loads above the opening and transmit them safely to the abutments, jambs or piers on both sides. A support over an opening is usually required since the opening infilling such as a door or window frame will not have sufficient strength to carry the load through its own members.

## Type of Support ~

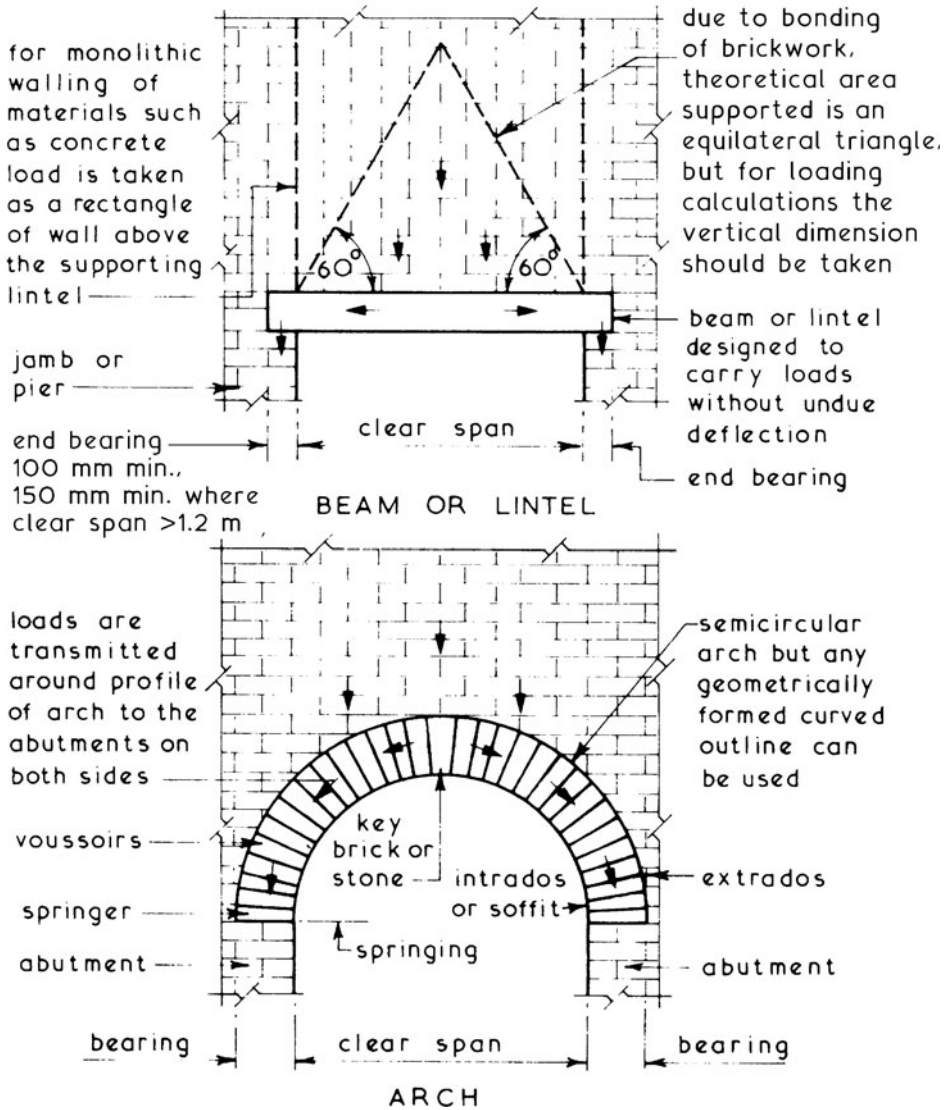

Arch Construction ~ by the arrangement of the bricks or stones in an arch over an opening it will be self-supporting once the jointing material has set and gained adequate strength. The arch must therefore be constructed over a temporary support until the arch becomes self-supporting. The traditional method is to use a framed timber support called a centre. Permanent arch centres are also available for small spans and simple formats.

Typical Arch Formats ~

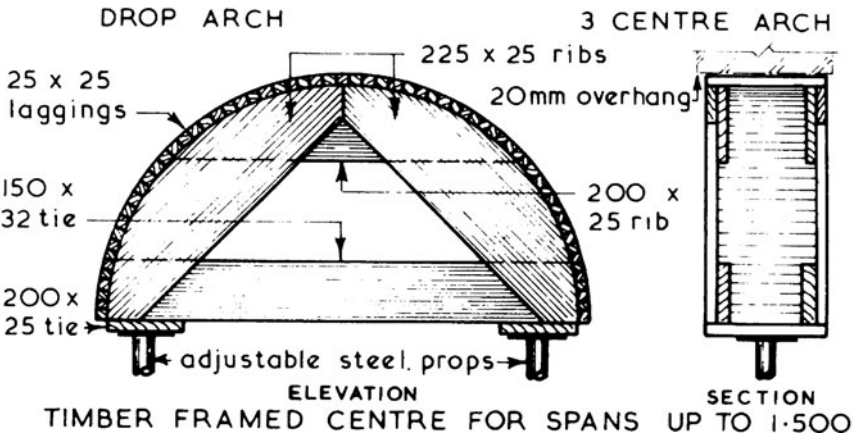
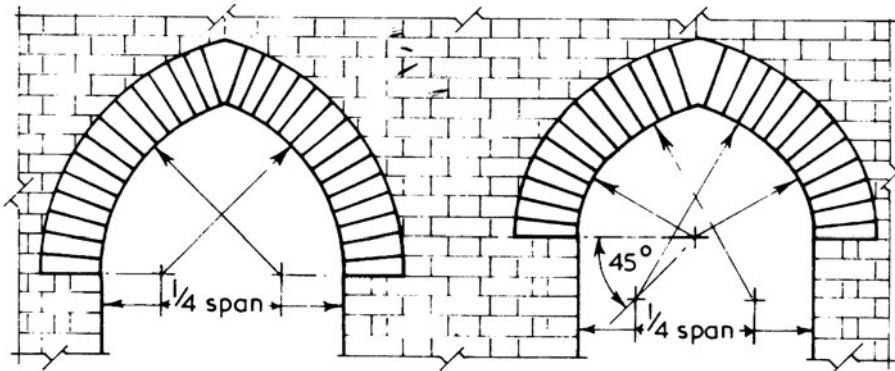
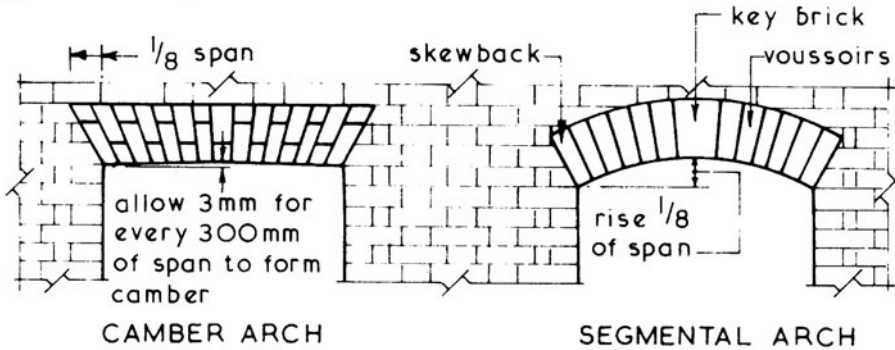

## Arch Cavity Tray

The profile of an arch does not lend itself to simple positioning of a damp-proof course. At best, it can be located horizontally at upper extrados level. This leaves the depth of the arch and masonry below the dpc vulnerable to dampness. Proprietary galvanised or stainless steel cavity trays resolve this problem by providing:

- \* Continuity of dpc around the extrados.
- \* Arch support/centring during construction.
- \* Arch and wall support after construction.

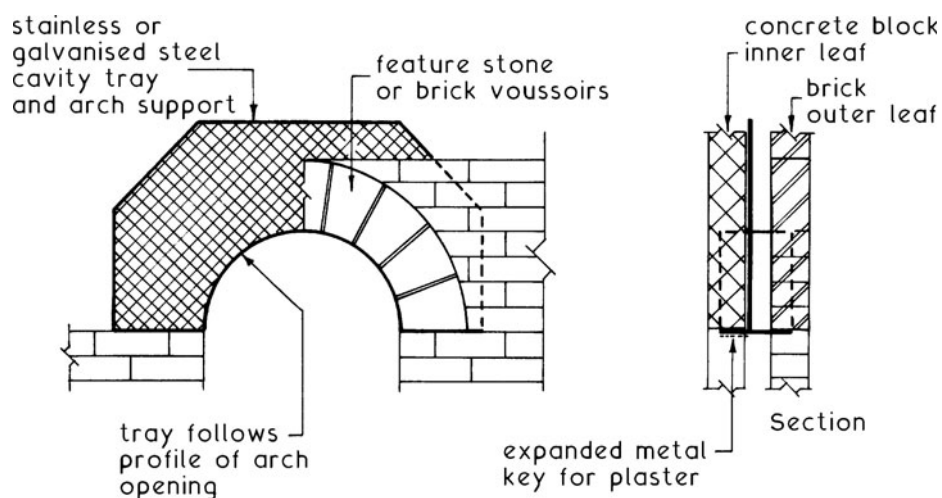

Standard profiles are made to the traditional outlines shown on the previous two pages, in spans up to 2 m. Other options may also be available from some manufacturers. Irregular shapes and spans can be made to order.

Note: Arches in semicircular, segmental or parabolic form up to 2 m span can be proportioned empirically. For integrity of structure it is important to ensure sufficient provision of masonry over and around any arch.

The example in steel shown on the preceding page combines structural support with a damp-proof course, without the need for temporary support from a centre. Where traditional centring is retained, a lightweight preformed polypropylene cavity tray/dpc can be used. These factory-made plastic trays are produced in various thicknesses of 1.5 to 3 mm relative to spans up to about 2 m. Arch centres are made to match the tray profile and with care can be reused several times.

An alternative material is code 4 lead sheet.\* Lead is an adaptable material but relatively heavy. Therefore, its suitability is limited to small spans particularly with non-standard profiles.

\*BS EN 12588: Lead and lead alloys. Rolled lead sheet for building purposes. Lead sheet is coded numerically from 3 to 8 (1.25 to 3.50 mm - see page 531), which closely relates to the traditional specification in lbs./sq. ft.

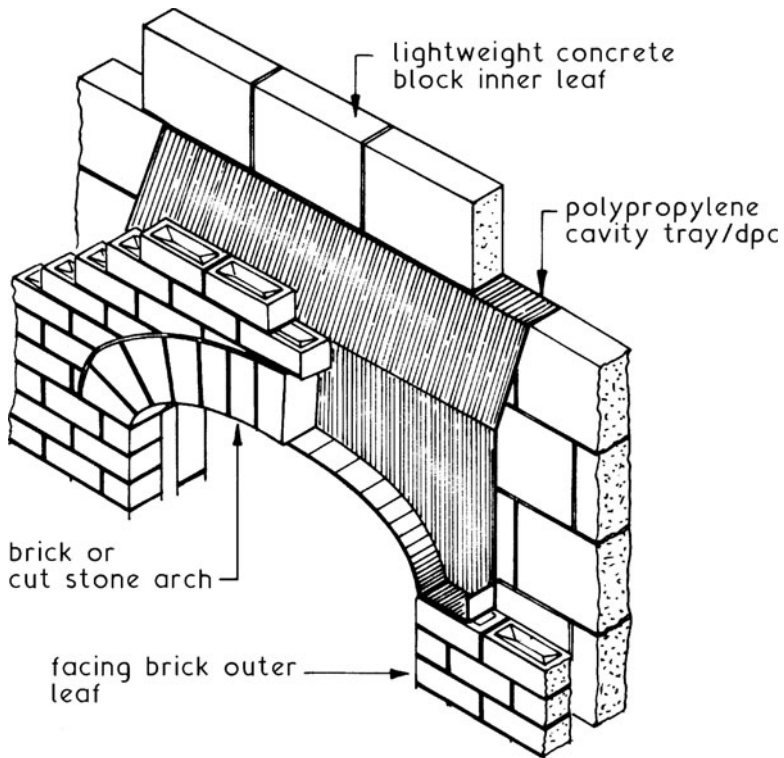

Ref. BS EN 1996: Design of masonry structures.



## Opening Details – Heads

Openings ~ these consist of a head, jambs and sill. Different methods can be used in their formation, all with the primary objective of adequate support around the void. Details relate to older/existing construction and where thermal insulation is not critical. Application limited – see pages 580 and 581.

Typical Head Details ~

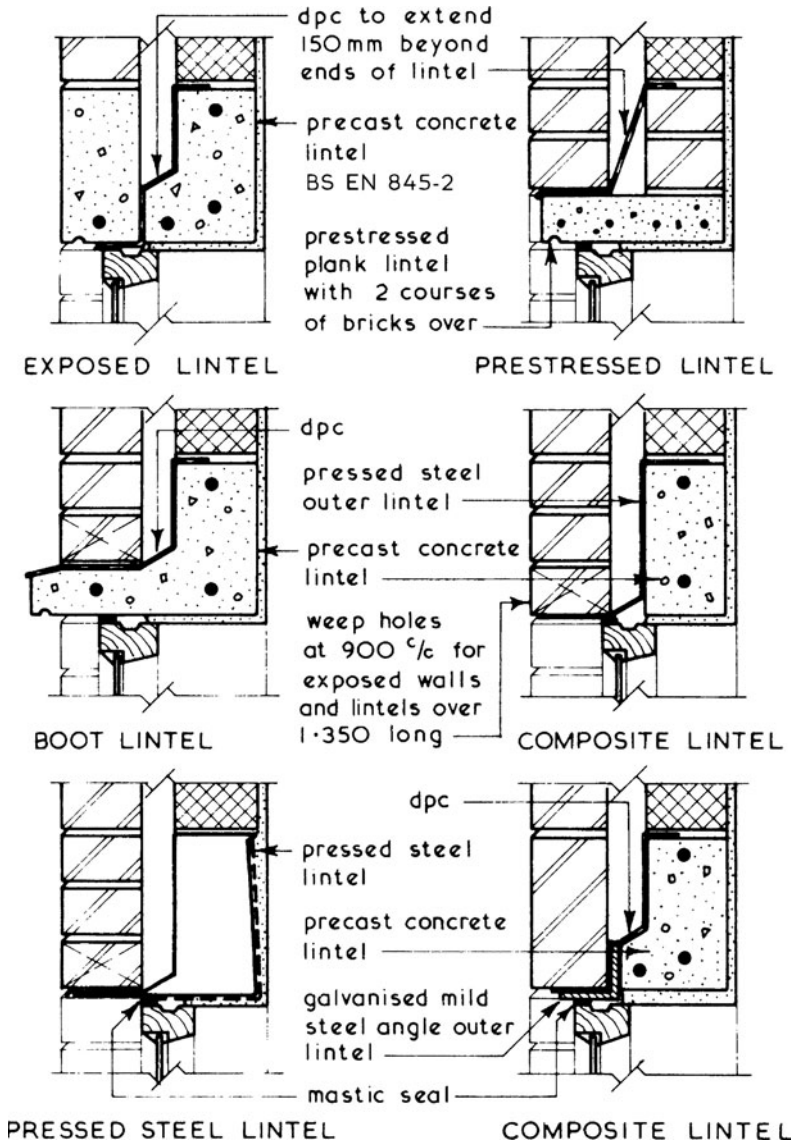

Ref. BS EN 845-2: Specification for ancillary components for masonry. Lintels.

Jamb ~ these may be bonded as in solid walls or unbonded as in cavity walls. The latter must have some means of preventing the ingress of moisture from the outer leaf to the inner leaf and hence the interior of the building. Details as preceding page.

Application limited – see pages 580 and 581.

Typical Jamb Details ~

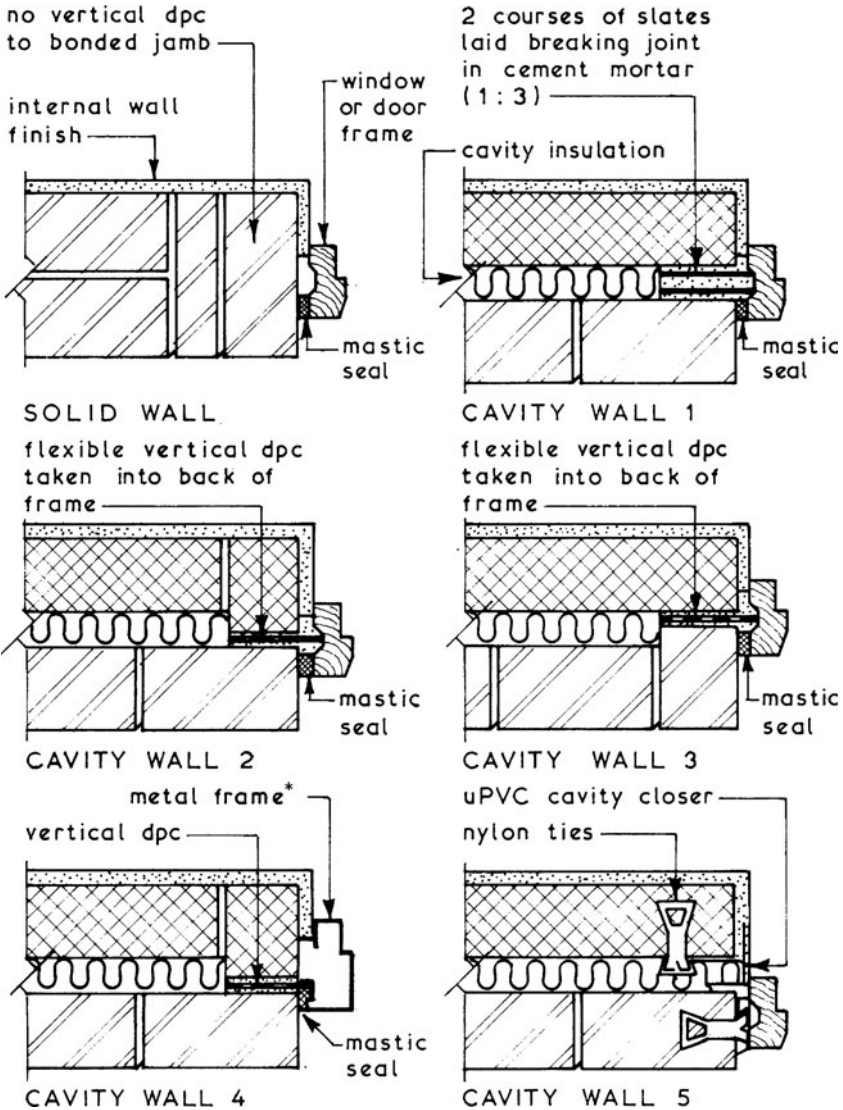

\*Ref. BS 1245: Pedestrian doorsets and door frames made from sheet steel. Specification.

## Opening Details – Sills

Sills ~ the primary function of any sill is to collect the rainwater which has run down the face of the window or door and shed it clear of the wall below.

Timber Sill 1, Cast Stone Subsill and Slate Sill have limited applications - see pages 580 and 581.

Typical Sill details ~

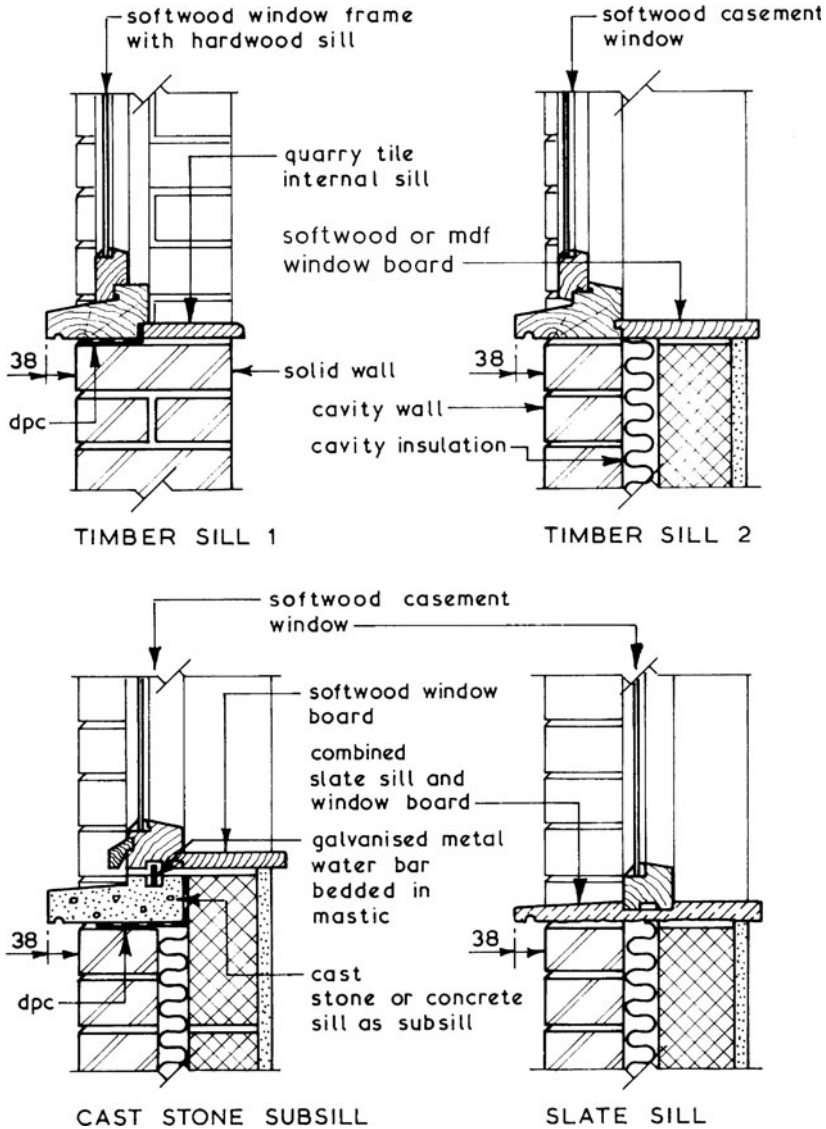

Ref. BS 5642-1: Sills and copings. Specification for window sills of precast concrete, cast stone, clayware, slate and natural stone.

# Opening Details – Checked Head, Jamb and Sill

Traditional Construction – checked rebates or recesses in masonry solid walls were often provided at openings to accommodate door and window frames. This detail was used as a means to complement frame retention and prevent weather intrusion.

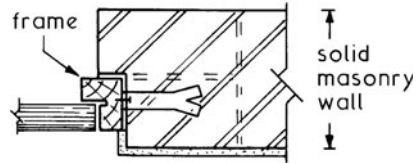

Typical checked masonry (pre-1940s)

Exposure Zones – checked reveal treatment is now required mainly where wind-driven rain will have most impact. This is primarily in the south-west and west coast areas of the British Isles, plus some isolated inland parts that will be identified by their respective local authorities.

Typical Checked Opening Details –

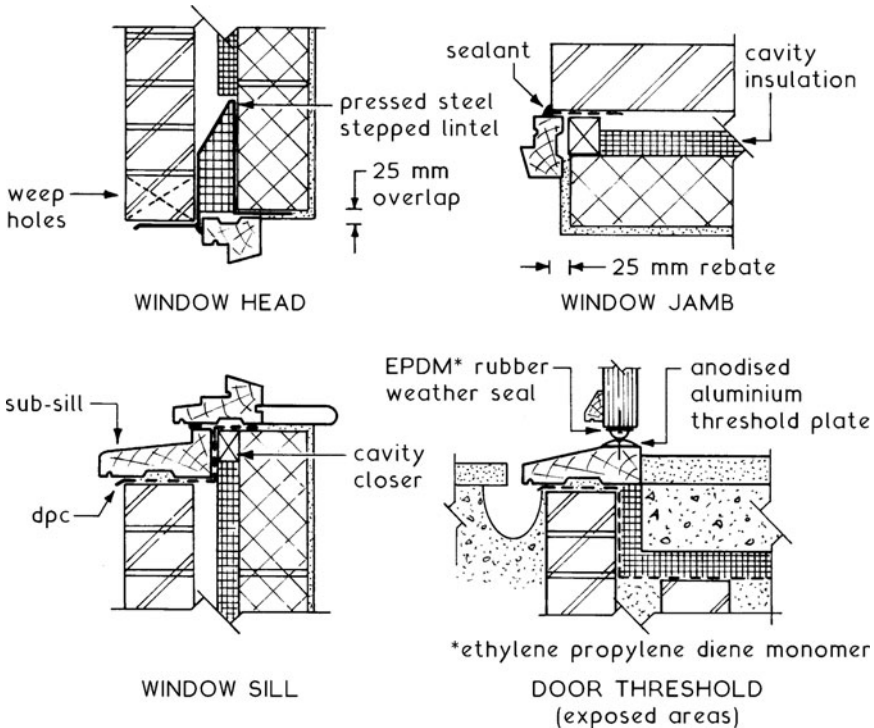

Ref. Building Regulations, Approved Document C. Section 5: Walls. Driving rain exposure zones 3 and 4.

## Windows – Performance Requirements

A window must be aesthetically acceptable in the context of building design and the surrounding environment.

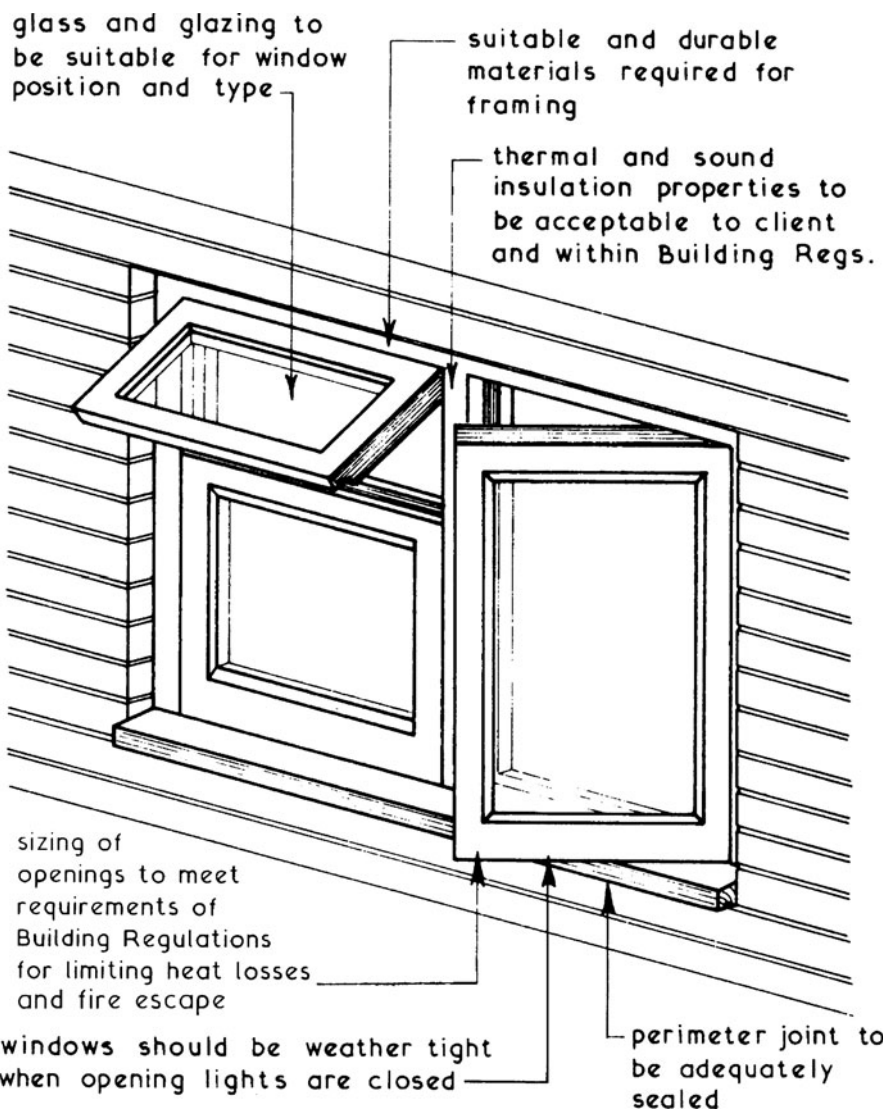

Windows should be selected or designed to resist wind loadings, be easy to clean and provide for safety and security. They should be sited to provide visual contact with the outside.

Habitable upper floor rooms should have a window for emergency escape. Min. opening area, 0.330m<sup>2</sup>. Min. height and width, 0.450m. Max height of opening, 1.100m above floor.

sash side hung  
opening out

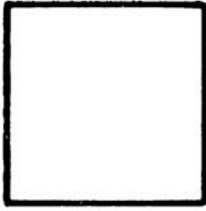

FIXED LIGHT

usually used in conjunction with other types

sash top hung  
opening out

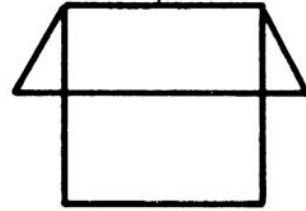

SIDE HUNG  
CASEMENT  
simplest and  
cheapest type  
of opening window

TOP HUNG  
CASEMENT  
usually of small  
size for controlled  
ventilation



BOTTOM HUNG  
CASEMENT  
use as for top  
hung casement

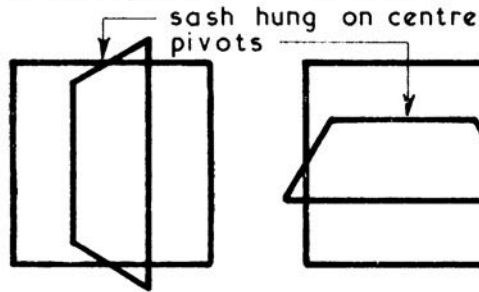

VERTICAL  
PIVOT  
high performance windows - dearer  
than casement types - can be obtained  
as reversible for easy cleaning

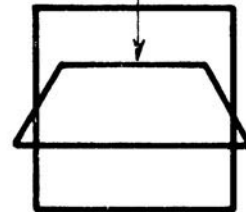

HORIZONTAL  
PIVOT

sashes hung on spring  
balances or weights

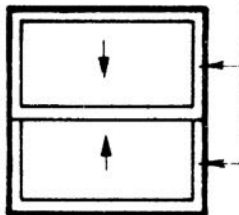

DOUBLE HUNG  
SLIDING SASH

gives good controlled ventilation  
without any forward or backward  
projection of sash



HORIZONTAL  
SLIDING SASH

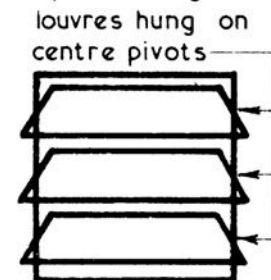

LOUVRE

good ventilation  
with only small  
projections of  
louvres

# Timber Casement Windows

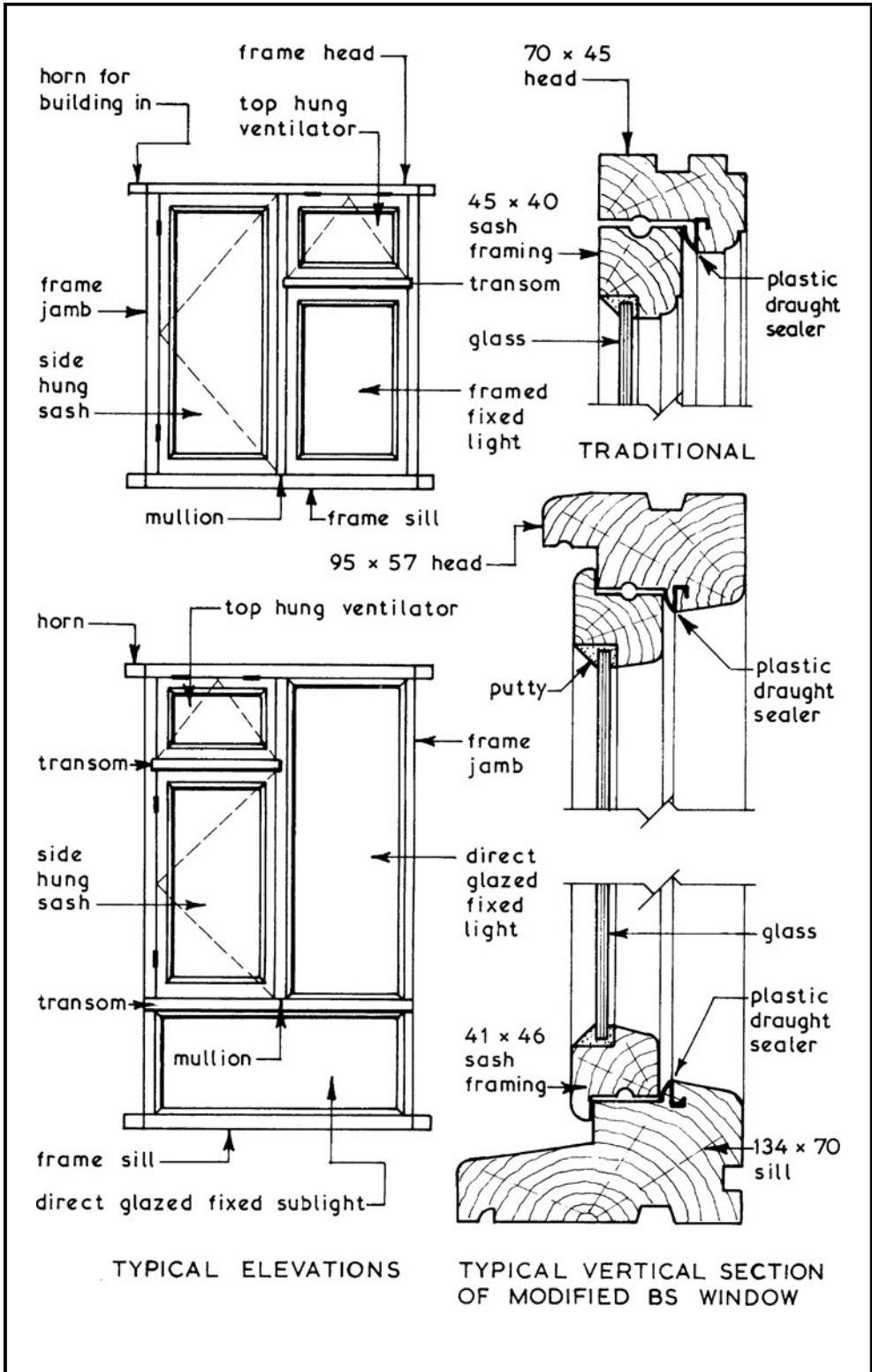

## High Performance Timber Casement Windows

The standard range of casement windows used in the UK was derived from the English Joinery Manufacturer's Association (EJMA) designs of some 50 years ago. These became adopted in BS 644: Timber windows and doorsets. Fully finished factory assembled windows of various types. Specification. A modified type is shown on the preceding page. Contemporary building standards require higher levels of performance in terms of thermal and sound insulation (Bldg. Regs. Pt. L and E), air permeability, watertightness and wind resistance (BS ENs 1026, 1027 and 12211, respectively). This has been achieved by adapting Scandinavian designs with double and triple glazing to attain U-values as low as  $1.2 \text{ W/m}^2\text{K}$  and a sound reduction of 50 dB.

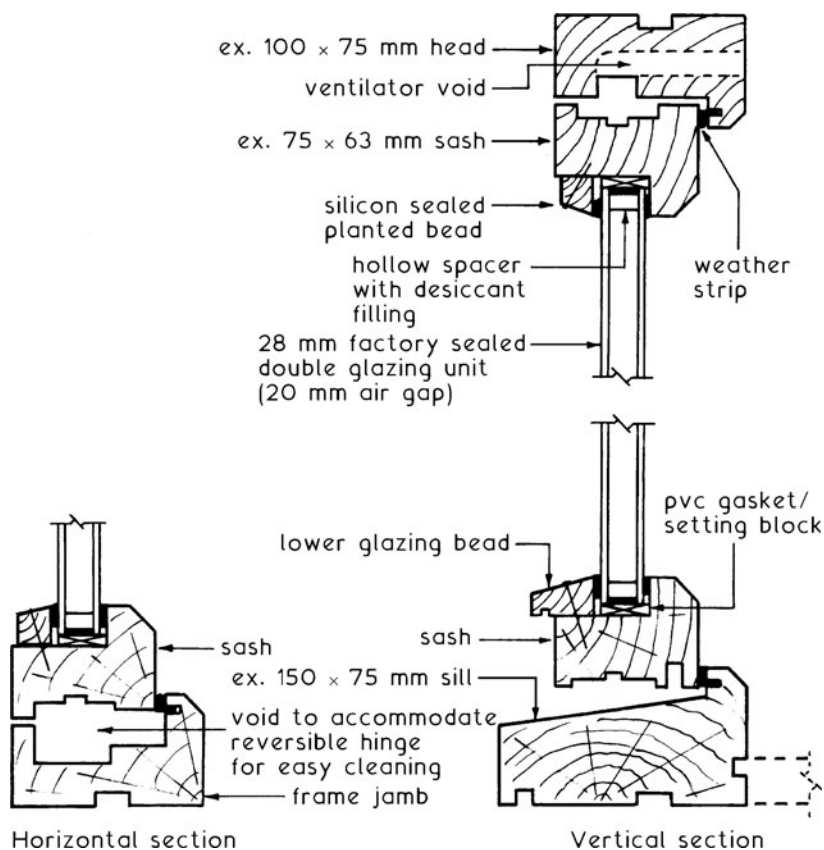

Further refs.:

BS 6375 series: Performance of windows and doors.

BS 6375-1: Classification for weather tightness.

BS 6375-2: Classification for operation and strength characteristics.

PAS 24: Enhanced security performance requirements for doorsets and windows in the UK



# Timber Standard Double Glazed Casement Windows

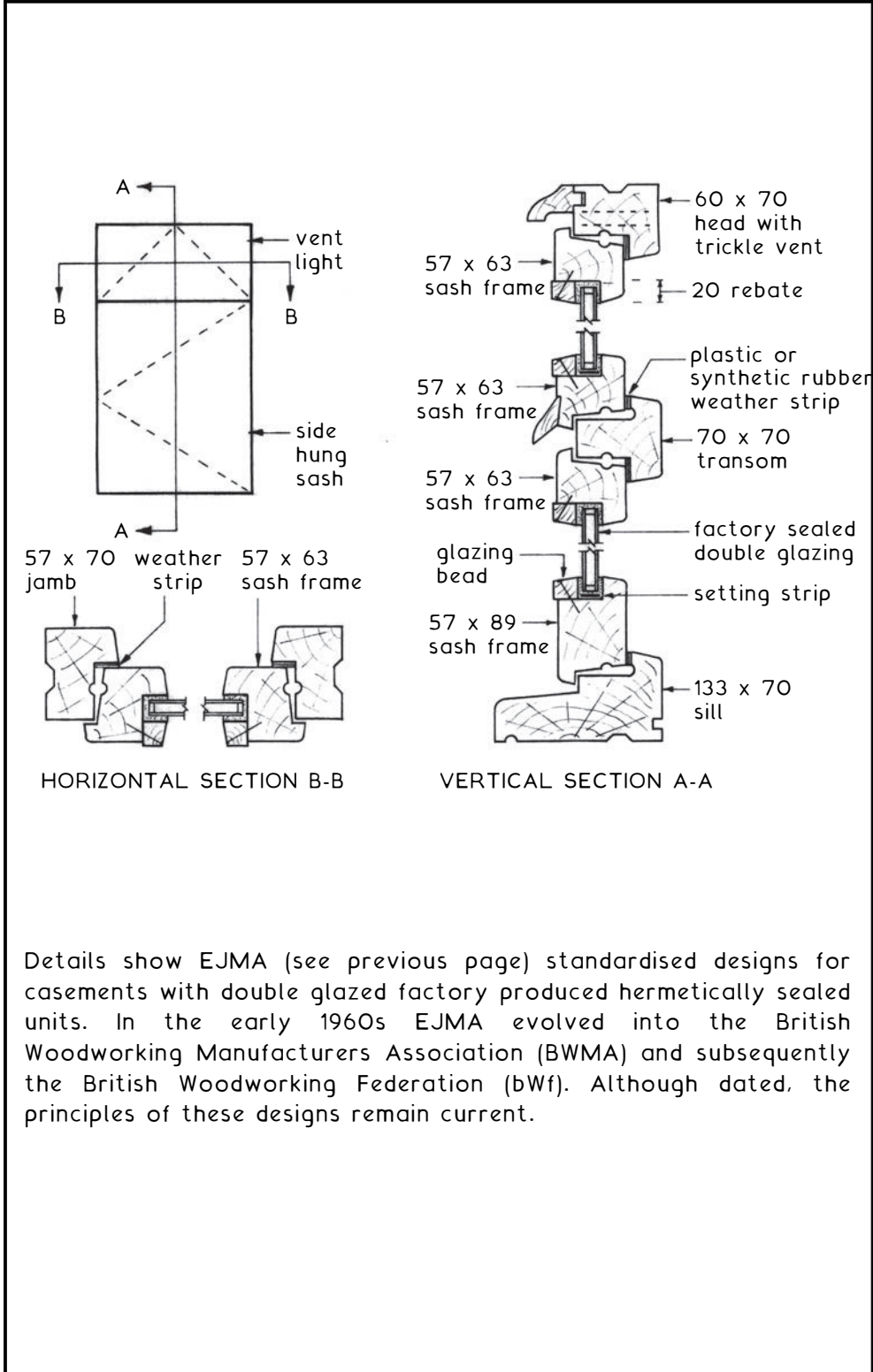

Details show EJMA (see previous page) standardised designs for casements with double glazed factory produced hermetically sealed units. In the early 1960s EJMA evolved into the British Woodworking Manufacturers Association (BWMA) and subsequently the British Woodworking Federation (bWf). Although dated, the principles of these designs remain current.

Metal Windows ~ these can be obtained in steel (BS 6510) or in aluminium alloy (BS 4873). Steel windows are cheaper in initial cost than aluminium alloy but have higher maintenance costs over their anticipated life, both can be obtained fitted into timber subframes. Generally they give a larger glass area for any given opening size than similar timber windows but they can give rise to condensation on the metal components. Page 454 shows an example of an energy efficient improvement.

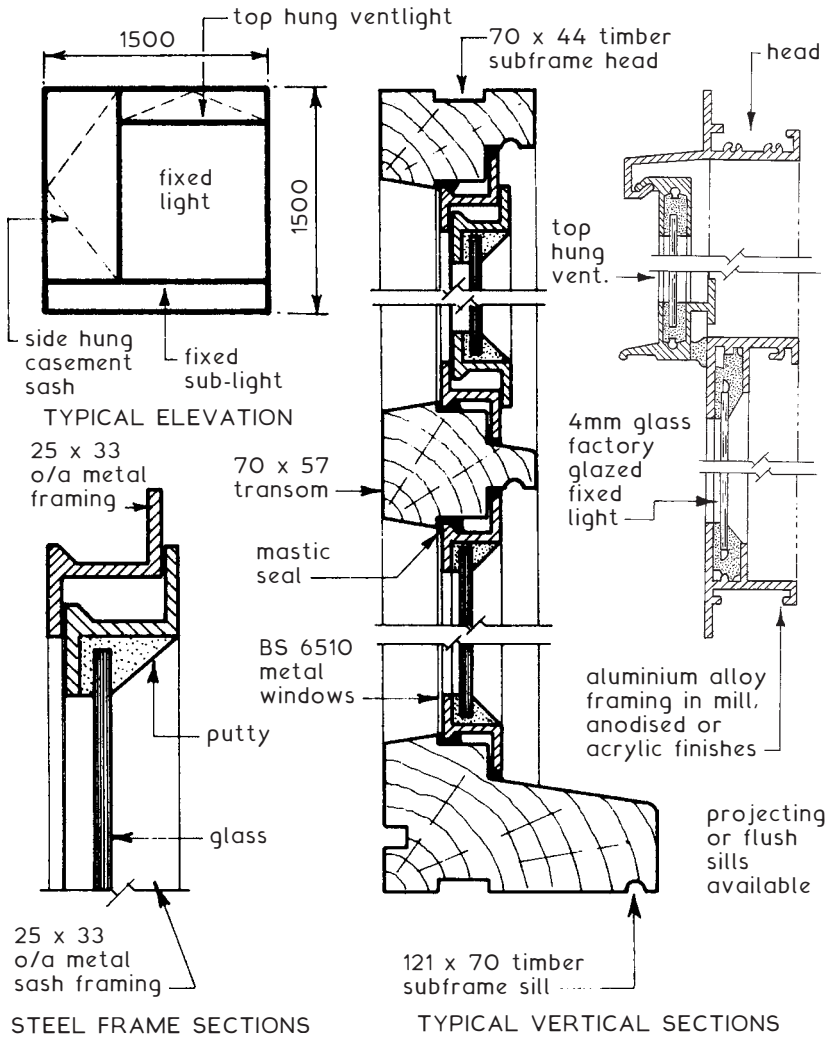

Refs.:

BS 4873: Aluminium alloy windows and doorsets. Specification.

BS 6510: Steel-framed windows and glazed doors. Specification.

# Casement Windows – Ironmongery

Timber Windows ~ wide range of ironmongery available which can be factory fitted or supplied and fixed on site.

Metal Windows ~ ironmongery usually supplied with and factory fitted to the windows.

Typical Examples ~

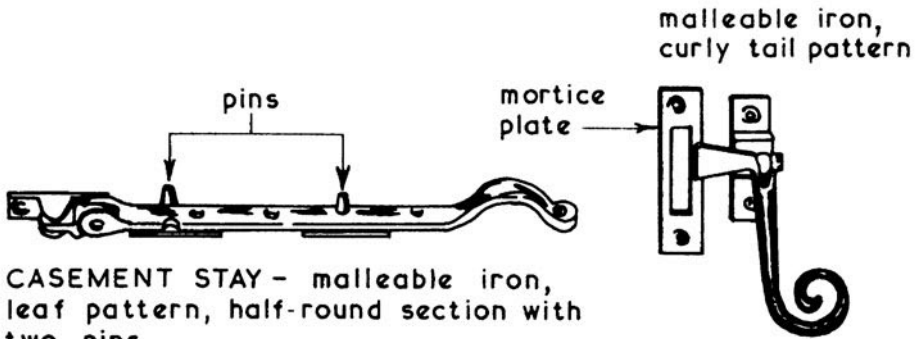

**CASEMENT STAY** - malleable iron, leaf pattern, half-round section with two pins  
 Sizes: 200 ; 250 and 300 mm

**CASEMENT FASTENER**



**CASEMENT STAY** - cast aluminium, plain end pattern with one pin  
 Sizes: 250 and 300mm

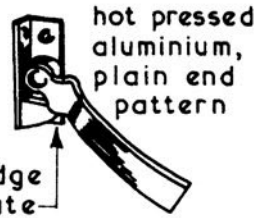

**CASEMENT FASTENER**



**CASEMENT STAY** - steel and brass, sliding screw-down pattern  
 Sizes: 250 and 300 mm

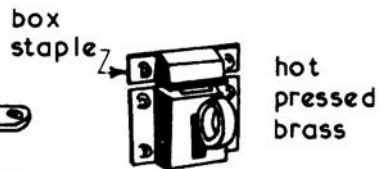

**VENTLIGHT CATCH**  
 used with bottom hung ventlights

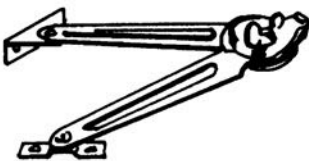

**CASEMENT STAY** - steel, stayput pattern  
 Arm Sizes: 100 ; 140 and 175 mm

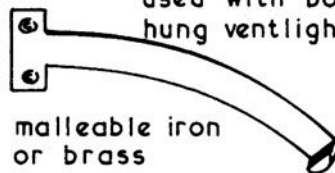

**QUADRANT STAY**

# Sliding Sash Windows – Vertical Weight Balanced

Sliding Sash Windows ~ these are an alternative format to the conventional side hung casement windows and can be constructed as a vertical or double hung sash window or as a horizontal sliding window in timber, metal, plastic or in any combination of these materials. The performance and design functions of providing daylight, ventilation, vision out, etc. are the same as those given for traditional windows in Windows – Performance Requirements on page 432.

Typical Double Hung Weight Balanced Window Details ~

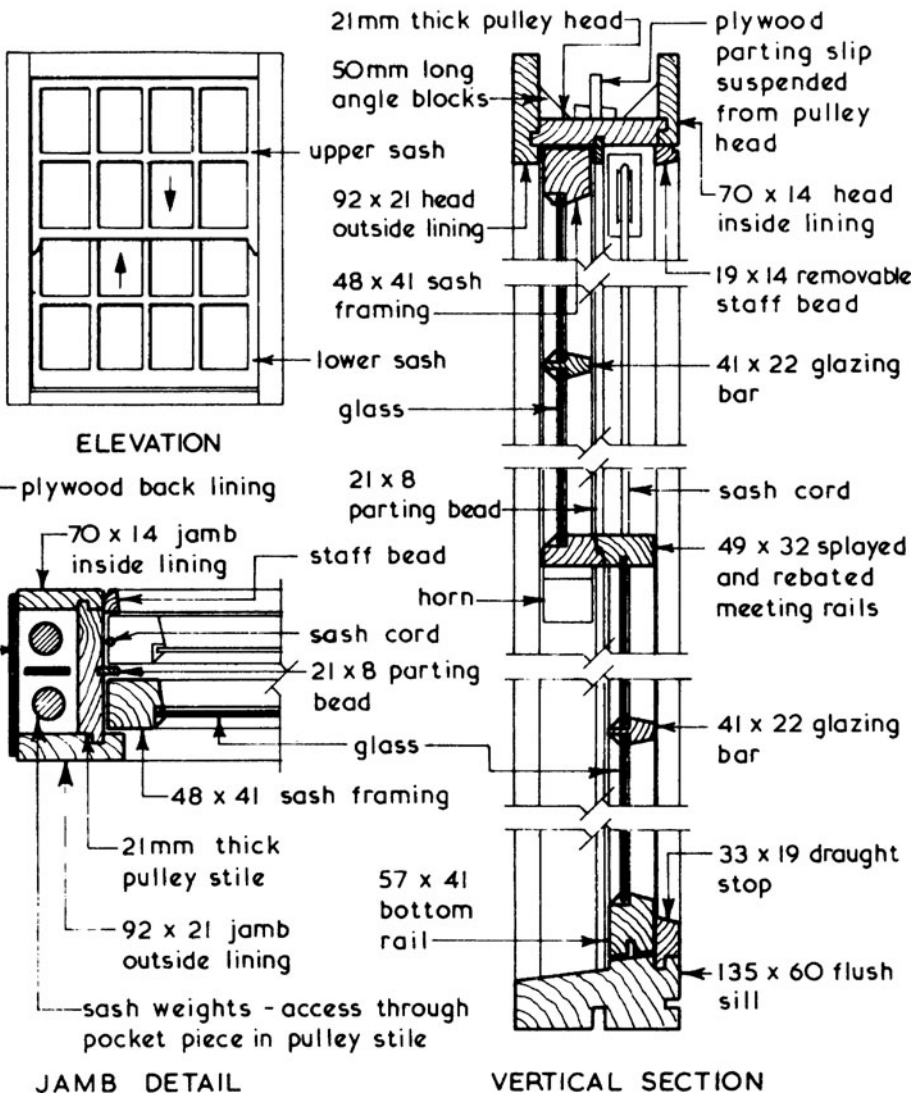

# Sliding Sash Windows – Weight Balanced Details

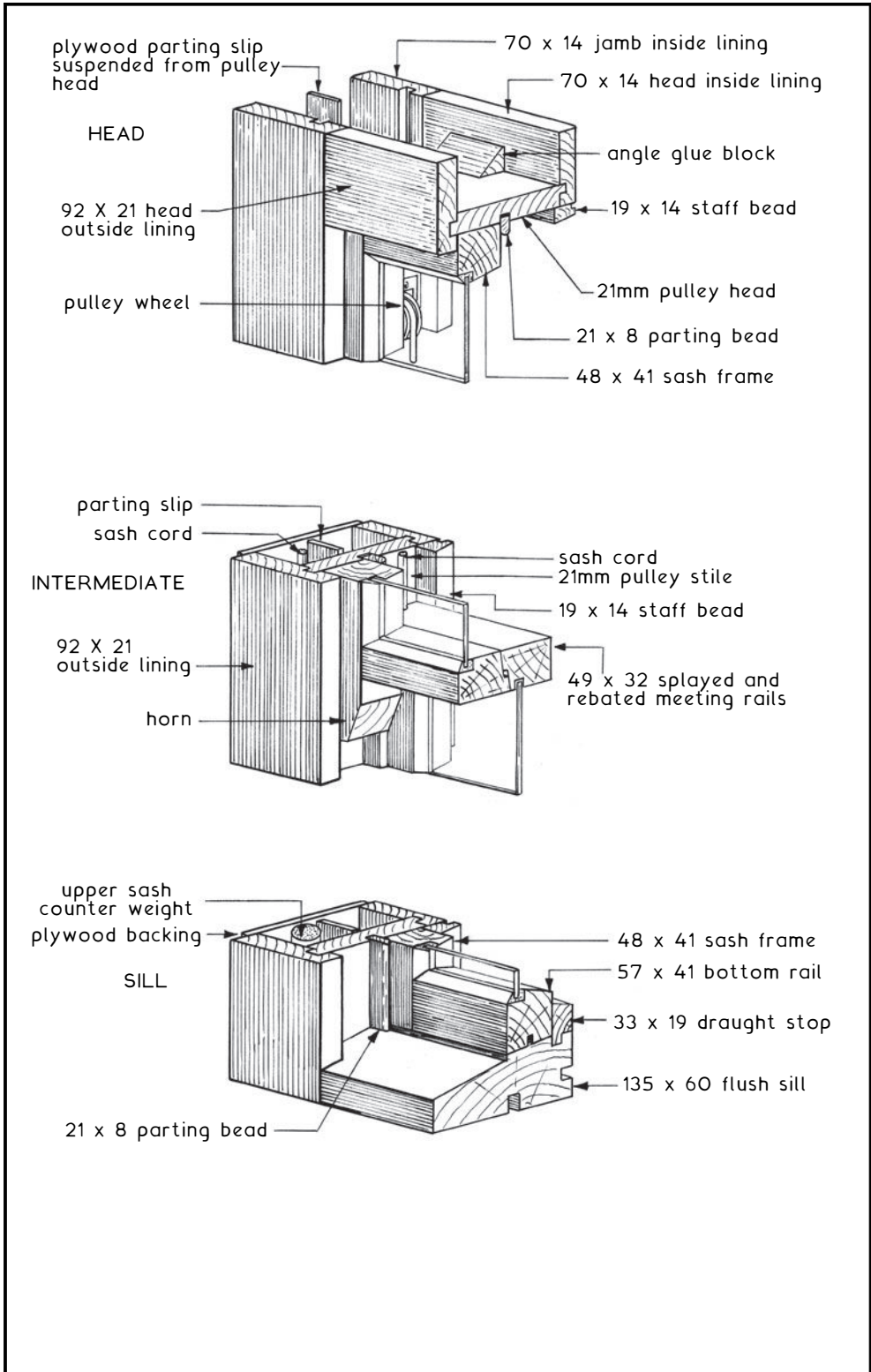

# Sliding Sash Windows – Vertical Spring Balanced

Double Hung Sash Windows ~ these vertical sliding sash windows come in two formats when constructed in timber. The weight balanced format is shown on the preceding two pages. The alternative spring balanced type is illustrated below and overleaf. Various formats for sliding windows are specified in BS 644: Timber windows and doorsets.

Typical Double Hung Spring Balanced Window Details ~

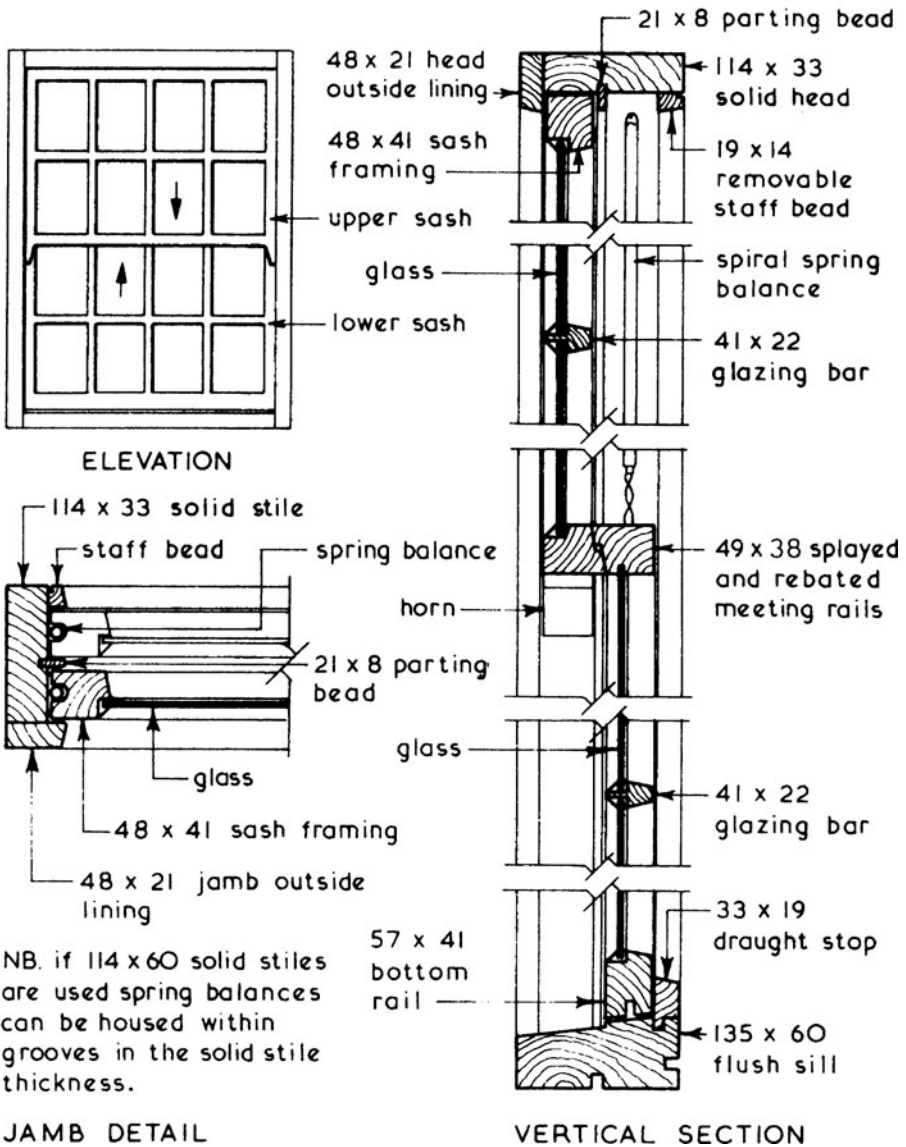

# Sliding Sash Windows – Spring Balanced Details

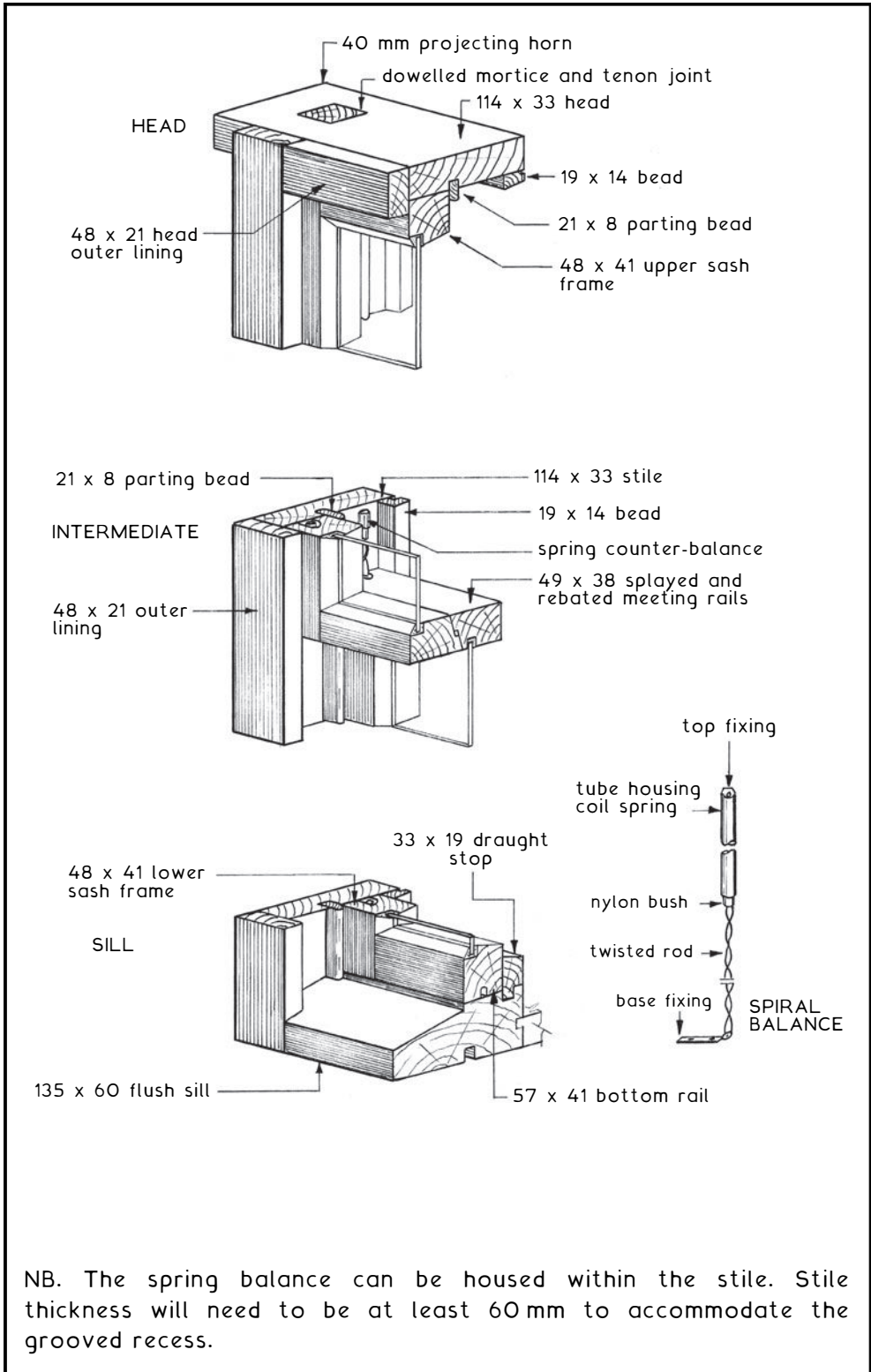

Horizontally Sliding Sash Windows ~ these are an alternative format to the vertically sliding or double hung sash windows shown on pages 439 to 442 and can be constructed in timber, metal, plastic or combinations of these materials with single or double glazing. A wide range of arrangements are available with two or more sliding sashes which can have a ventlight incorporated into the outer sliding sash.

Typical Horizontally Sliding Sash Window Details ~

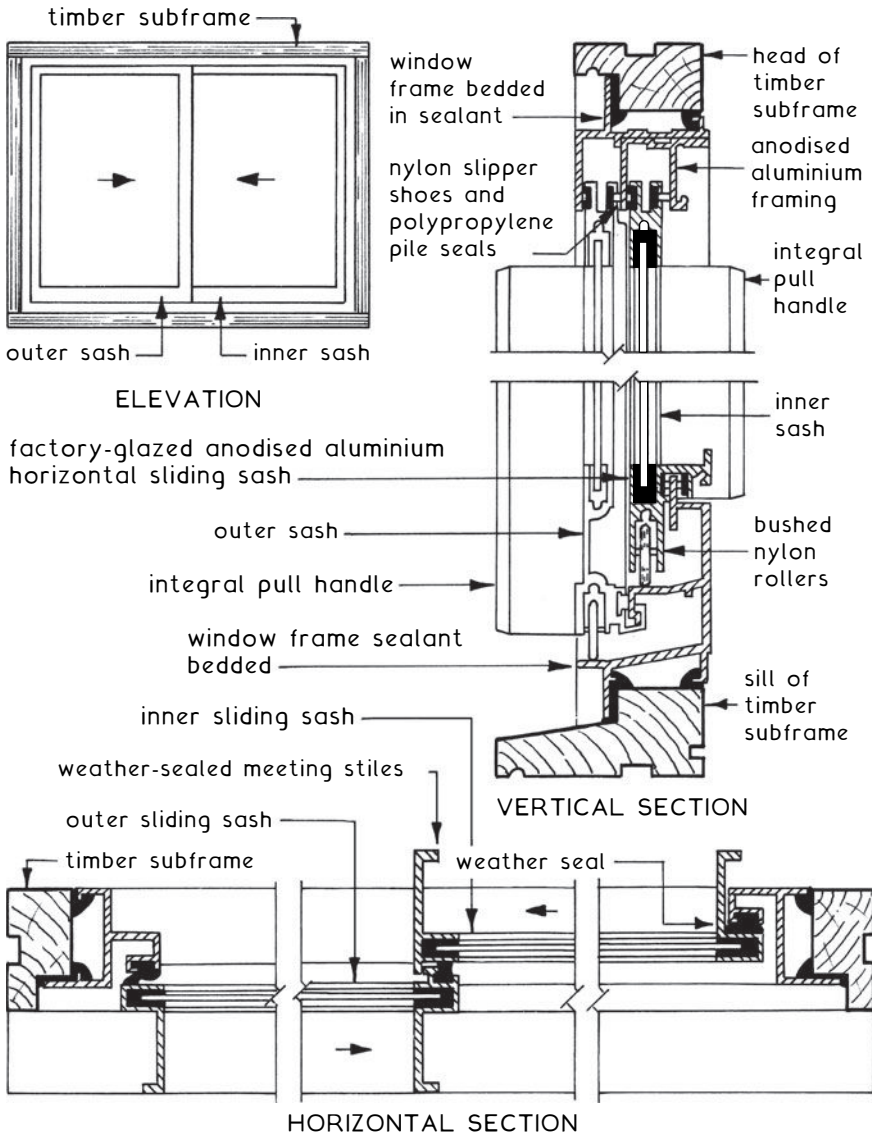



## Pivot Windows

Pivot Windows ~ like other windows these are available in timber, metal, plastic or in combinations of these materials.

They can be constructed with centre jamb pivots enabling the sash to pivot or rotate in the horizontal plane or alternatively the pivots can be fixed in the head and sill of the frame so that the sash rotates in the vertical plane.

Typical Example ~

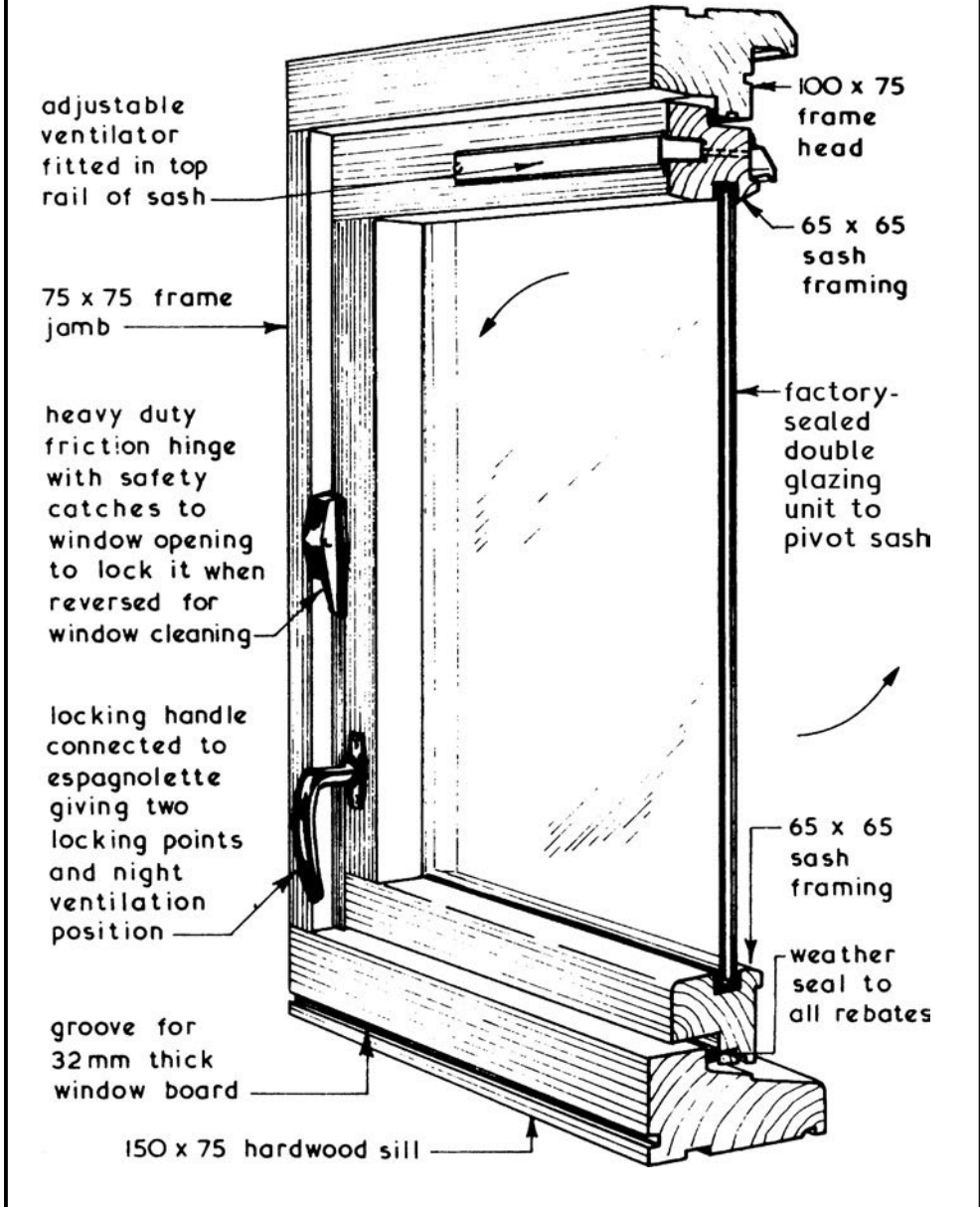

Bay Windows ~ these can be defined as any window with sidelights which projects in front of the external wall and is supported by a sill height wall. Bay windows not supported by a sill height wall are called oriel windows. They can be of any window type, constructed from any of the usual window materials and are available in three plan formats, namely square, splay and circular or segmental. Timber corner posts can be boxed, solid or jointed, the latter being the common method.

Typical Examples ~

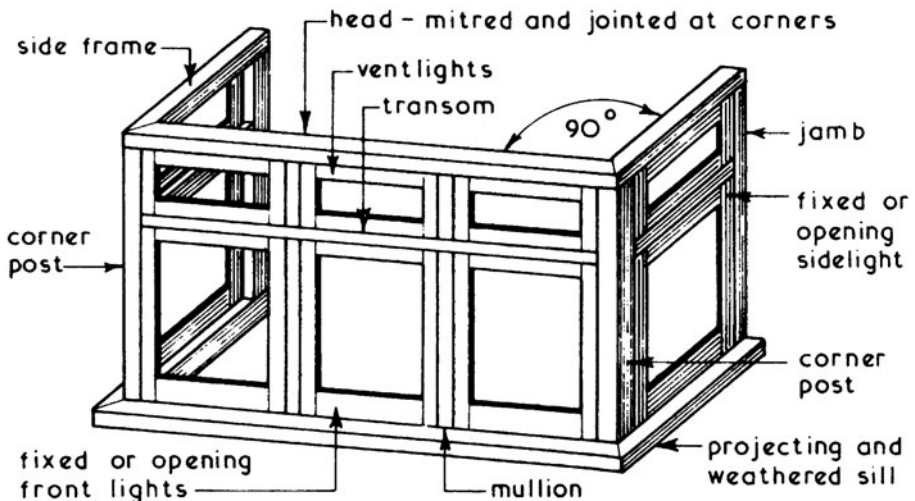

TYPICAL SQUARE BAY WINDOW (665mm projection)

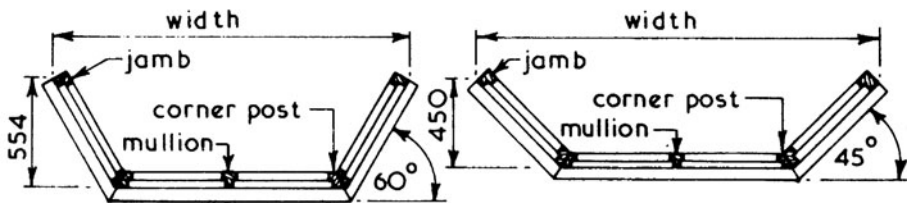

60° SPLAY BAY WINDOW AND 45° SPLAY BAY WINDOW

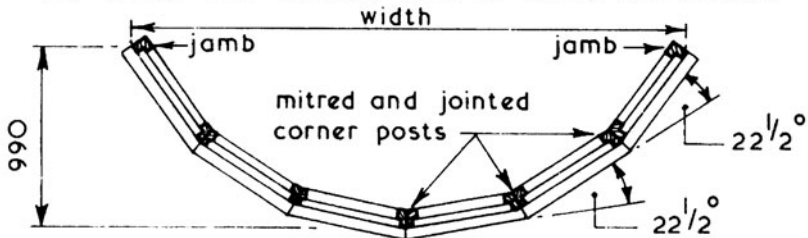

TYPICAL 6 LIGHT CIRCULAR OR SEGMENTAL BAY WINDOW

Schedules ~ the main function of a schedule is to collect together all the necessary information for a particular group of components such as windows, doors and drainage inspection chambers. There is no standard format for schedules but they should be easy to read, accurate and contain all the necessary information for their purpose. Schedules are usually presented in a tabulated format which can be related to and read in conjunction with the working drawings.

Typical Example ~

WINDOW SCHEDULE – Sheet 1 of 1									
Contract Title & Number: Lane End Farm – H 341/80			Drawn By: RC	Date: 14/4/01	Rev.				
Number	Type or catalogue ref.	Material	Overall size w x h	Glass	Ironmongery	Sill			
						External	Internal		
2	213 CV	hardwood	1200 x 1350	sealed units as supplied with frames	supplied with casements	2 cos. plain tiles subsill	150×150×15 quarry tiles		
4	309 CVC	ditto	1770 x 900	ditto	ditto	ditto	25mm thick softwood		
4	313 CVC	ditto	1770 x 1350	ditto	ditto	sill of frame	ditto		

Window manufacturers identify their products with a notation that combines figures with numbers. The objective is to simplify catalogue entries, specification clauses and schedules. For example:

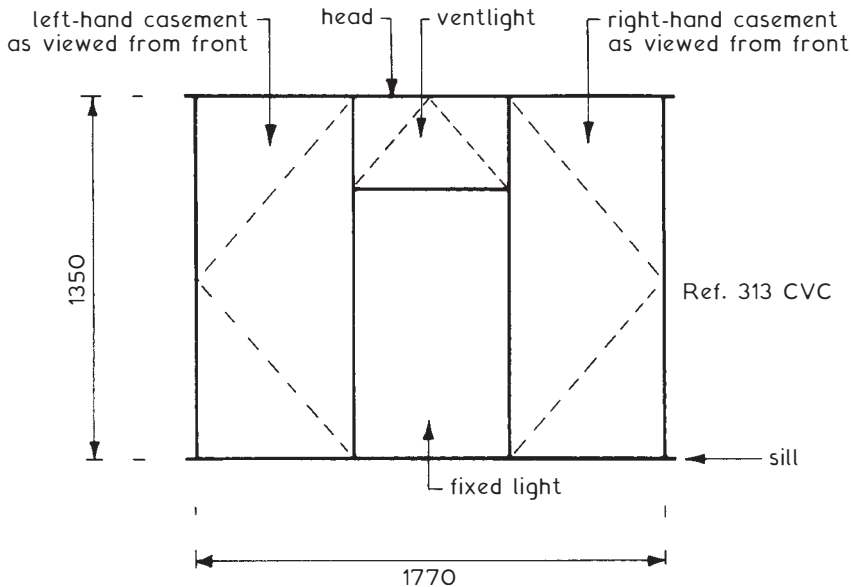

Notation will vary to some extent between the different joinery producers. The example of 313 CVC translates to:

3 = width divided into three units.

13 = first two dimensions of standard height, i.e. 1350mm.

C = casement.

V = ventlight.

Other common notations include:

N = narrow light.

P = plain (picture type window, i.e. no transom or mullion).

T = through transom.

S = sub-light, fixed.

VS = ventlight and sub-light.

F = fixed light.

B = bottom casement opening inwards.

RH/LH = right or lefthand as viewed from the outside.

## Glass and Glazing

Glass ~ this material is produced by fusing together soda, lime and silica with other minor ingredients such as magnesia and alumina. A number of glass types are available for domestic work and these include:

Clear Float ~ used where clear, undistorted vision is required. Available thicknesses range from 3mm to 25mm.

Clear Sheet ~ suitable for all clear glass areas but because the two faces of the glass are never perfectly flat or parallel some distortion of vision usually occurs. This type of glass is gradually being superseded by the clear float glass. Available thicknesses range from 3 mm to 6 mm.

Translucent Glass ~ these are patterned glasses, most having one patterned surface and one relatively flat surface. The amount of obscurity and diffusion obtained depends on the type and nature of pattern. Available thicknesses range from 4mm to 6mm for patterned glasses and from 5 mm to 10 mm for rough cast glasses.

Wired Glass ~ obtainable as a clear polished wired glass or as a rough cast wired glass with a nominal thickness of 7mm. Generally used where a degree of fire resistance is required. Georgian wired glass has a 12mm square mesh whereas the hexagonally wired glass has a 20mm mesh.

Choice of Glass ~ the main factors to be considered are:

1. Resistance to wind loadings.
2. Clear vision required.
3. Privacy.
4. Security.
5. Fire resistance.
6. Aesthetics.

Glazing Terminology ~

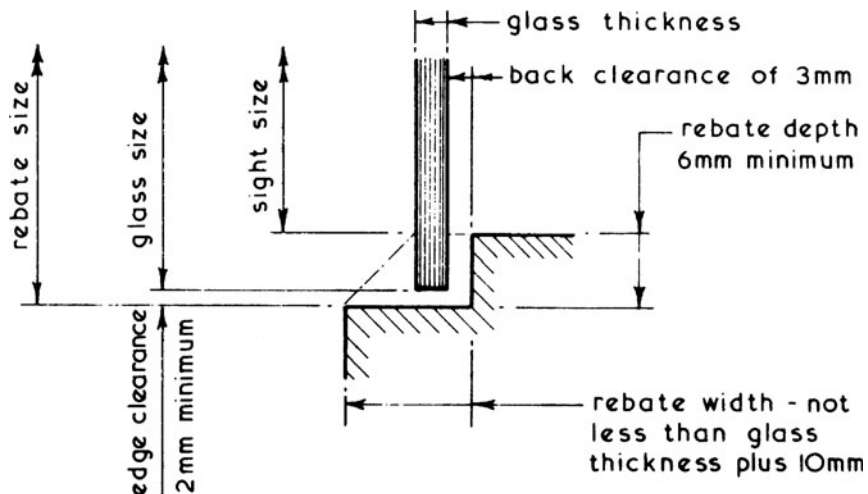

Glazing ~ the act of fixing glass into a frame or surround. In domestic work this is usually achieved by locating the glass in a rebate and securing it with putty or beading and should be carried out in accordance with the recommendations contained in the BS 6262 series: Glazing for buildings.

Timber Surrounds ~ linseed oil putty is the traditional material for sealing and retaining glass in wooden frames. It is a composite of crushed chalk and linseed oil (whiting). Rebate to be clean, dry and primed before glazing is carried out. Putty should be protected with paint within two weeks of application.

Metal Surrounds ~ metal casement putty if metal surround is to be painted - if surround is not to be painted a non-setting compound should be used.

A general purpose putty is also available. This combines the properties of the two types.

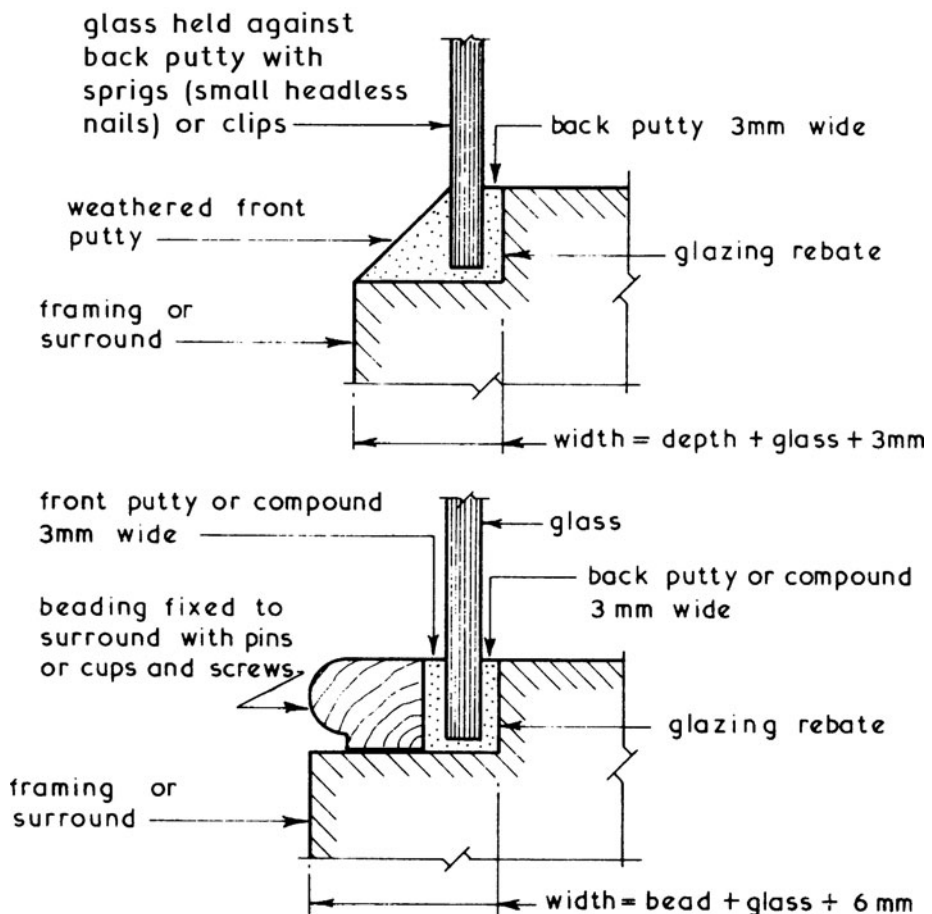

## Double Glazing

Double Glazing ~ as its name implies this is where two layers of glass are used instead of the traditional single layer. Double glazing can be used to reduce the rate of heat loss through windows and glazed doors or it can be employed to reduce the sound transmission through windows. In the context of thermal insulation this is achieved by having a small air or argon gas-filled space within the range of 6 to 20 mm between the two layers of glass. The sealed double glazing unit will also prevent internal misting by condensation. If metal frames are used these should have a thermal break incorporated into their design. All opening sashes in a double glazing system should be fitted with adequate weather seals to reduce the rate of heat loss through the opening clearance gap.

In the context of sound insulation three factors affect the performance of double glazing. First, good installation to ensure airtightness, second, the weight of glass used and third, the size of air space between the layers of glass. The heavier the glass used the better the sound insulation and the air space needs to be within the range of 50 to 300 mm. Absorbent lining to the reveals within the air space will also improve the sound insulation properties of the system.

### Typical Examples ~

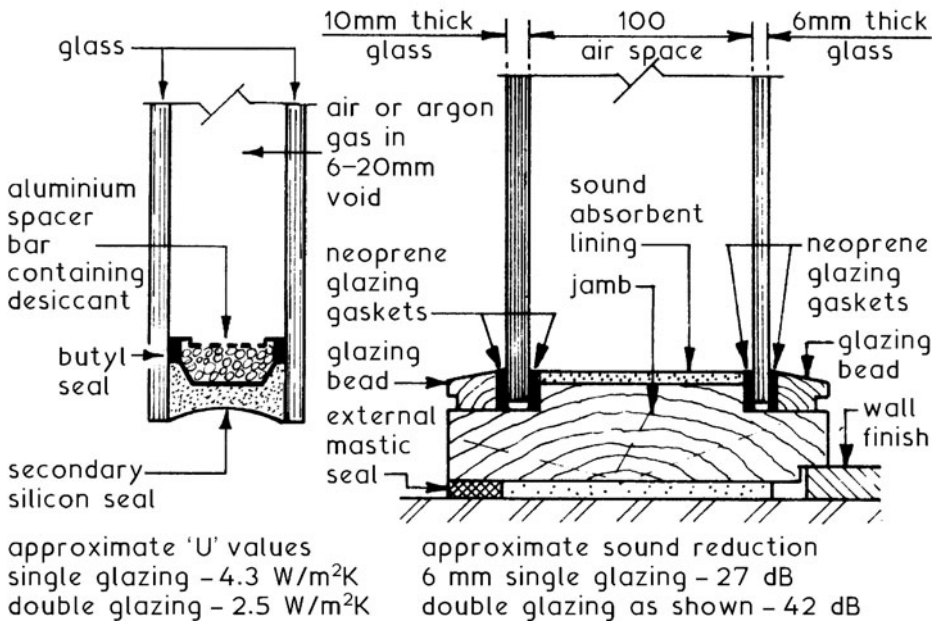

Secondary glazing of existing windows is an acceptable method for reducing heat energy losses at wall openings. Providing the existing windows are in a good state of repair, this is a cost-effective, simple method for upgrading windows to current energy efficiency standards. In addition to avoiding the disruption of removing existing windows, further advantages of secondary glazing include retention of the original window features, reduction in sound transmission and elimination of draughts. Applications are manufactured for all types of window, with sliding or hinged variations. The following details are typical of horizontal sliding sashes -

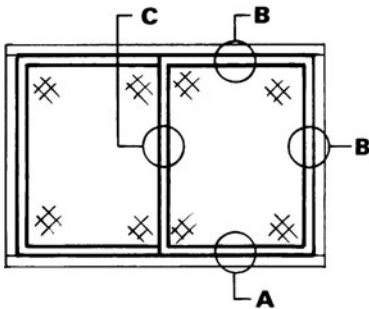

Elevation of frame

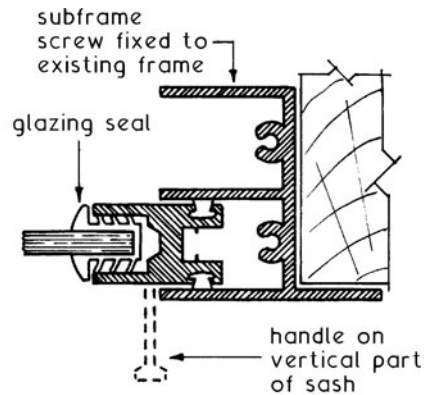

Detail B - Head and jamb

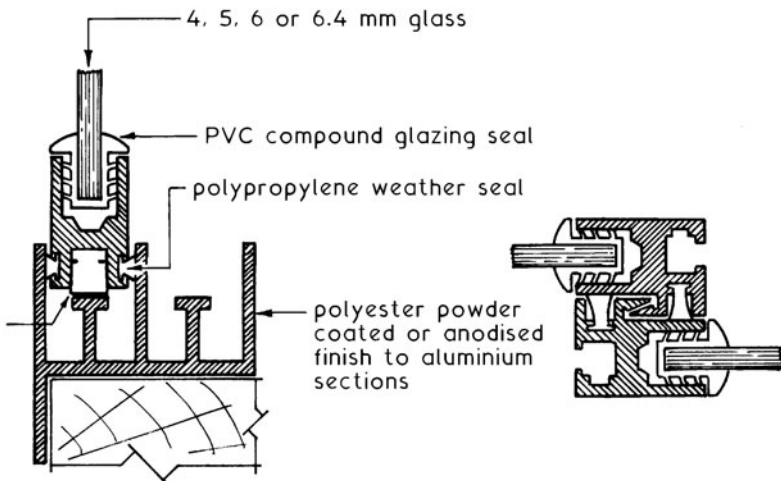

Detail A - Sill

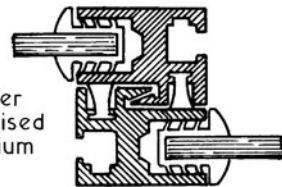

Detail C - Meeting rails



## Secondary Glazing (2)

Double hung weight balanced vertical sliding timber sash windows ~ a feature of many listed buildings, particularly those representing our architectural heritage. Preservation of original design is important and must be maintained, but there should also be a regard for current standards of insulation. Replacement with modern double glazed frames and casements is out of character and in many situations may be prohibited under the Planning (Listed Buildings and Conservation Areas) Act.

Application ~ secondary glazing fitted internally will not impact visually on the external elevation. If required it can be reversed, i.e. it can be removed with minimal inconvenience. Accessibility to the original window remains unimpeded. The illustration shows the simplicity of application to the window type detailed on page 439. Some minor changes may be necessary to replace the staff bead with a larger section to accommodate the casement frame and to modify the inner lining accordingly. External traditional appearance is preserved with the benefit of improved sound and thermal insulation, better security and elimination of draughts.

Modified traditional sliding sash window ~

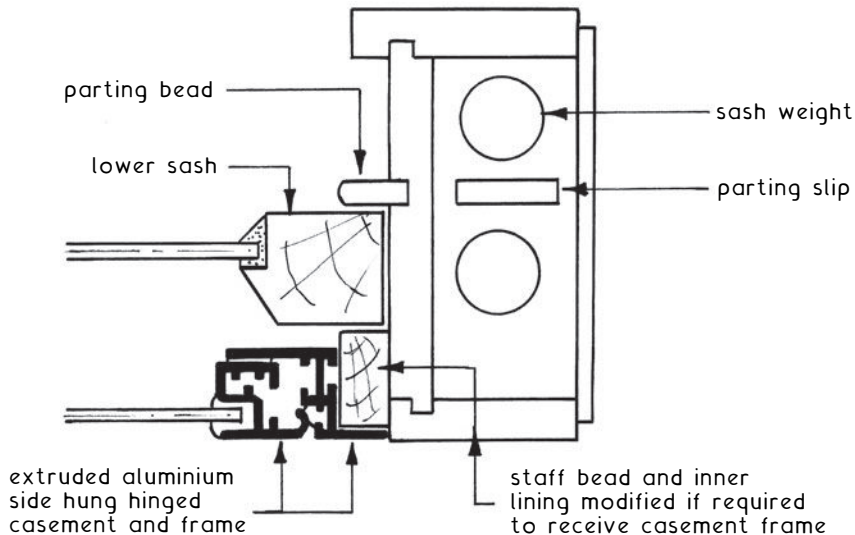

Low emissivity or 'Low E' glass is specially manufactured with a surface coating to significantly improve its thermal performance. The surface coating has a dual function:

1. Allows solar short wave light radiation to penetrate a building.
2. Reflects long wave heat radiation losses back into a building.

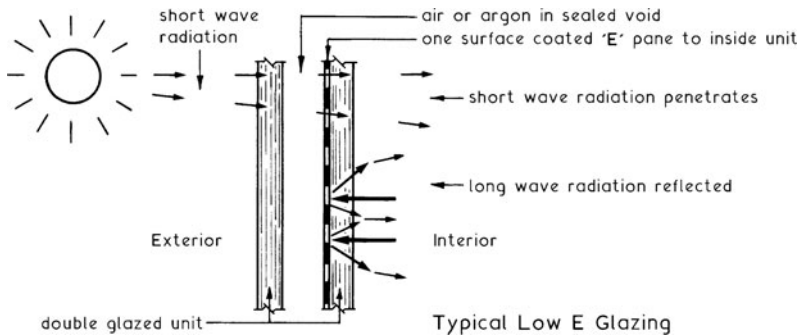

Manufacturing processes:

1. Pyrolytic hard coat, applied on-line as the glass is made. Emissivity range, 0.15–0.20, e.g. Pilkington 'K'.
2. A sputtered soft coat applied after glass manufacture. Emissivity range, 0.05–0.10, e.g. Pilkington 'Kappafloat' and 'Suncool High Performance'.

Note: In relative terms, uncoated glass has a normal emissivity of about 0.90.

Indicative U-values for multi-glazed windows of 4 mm glass with a 16mm void width:

Glazing type	uPVC or wood frame	metal frame
Double, air filled	2.7	3.3
Double, argon filled	2.6	3.2
Double, air filled Low E (0.20)	2.1	2.6
Double, argon filled Low E (0.20)	2.0	2.5
Double, air filled Low E (0.05)	2.0	2.3
Double, argon filled Low E (0.05)	1.7	2.1
Triple, air filled	2.0	2.5
Triple, argon filled	1.9	2.4
Triple, air filled Low E (0.20)	1.6	2.0
Triple, argon filled Low E (0.20)	1.5	1.9
Triple, air filled Low E (0.05)	1.4	1.8
Triple, argon filled Low E (0.05)	1.3	1.7

Notes:

1. A larger void and thicker glass will reduce the U-value, and vice versa.
2. Data for metal frames assumes a thermal break of 4 mm (see next page).
3. Hollow metal framing units can be filled with a closed cell insulant foam to considerably reduce U-values.

## Aluminium Hollow Profile Casement Windows

Extruded aluminium profiled sections are designed and manufactured to create lightweight hollow window (and door) framing members.

Finish - untreated aluminium is prone to surface oxidation. This can be controlled by paint application, but most manufacturers provide a variable colour range of polyester coatings finished in gloss, satin or matt.

Thermal insulation - poor insulation and high conductivity are characteristics of solid profile metal windows. This is much less apparent with hollow profile outer members, as they can be considerably enhanced by a thermal infilling of closed cell foam.

Condensation - a high strength two-part polyurethane resin thermal break between internal and external profiles inhibits cold bridging. This reduces the opportunity for condensation to form on the surface. The indicative U-values given on the preceding page are based on a thermal break of 4mm. If this is increased to 16mm, the values can be reduced by up to  $0.2 \text{ W/m}^2 \text{ K}$ .

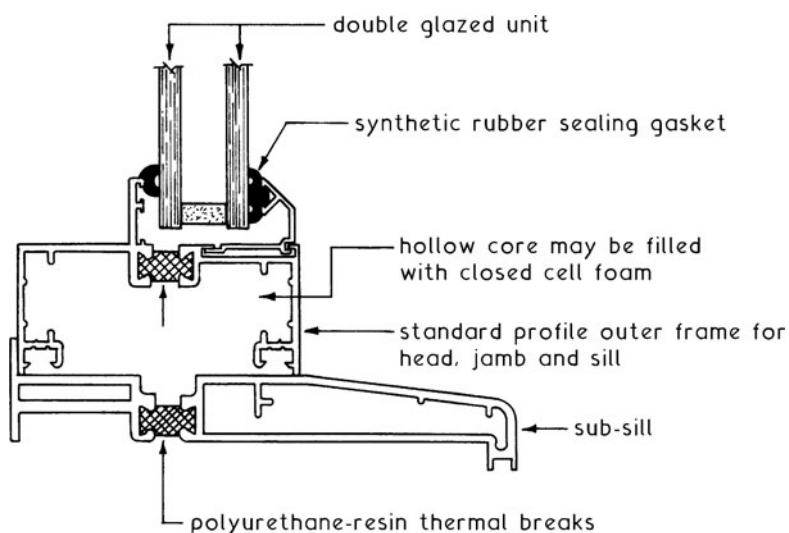

Hollow Core Aluminium Profiled Window Section

Inert gas fills ~ argon or krypton. Argon is generally used as it is the least expensive and more readily available. Where krypton is used, the air gap need only be half that with argon to achieve a similar effect. Both gases have a higher insulating value than air due to their greater density.

Densities ( $\text{kg/m}^3$ ):

Air = 1.20

Argon = 1.66

Krypton = 3.49

Argon and krypton also have a lower thermal conductivity than air.

Spacers ~ generally hollow aluminium with a desiccant or drying agent fill. The filling absorbs the initial moisture present in between the glass layers. Non-metallic spacers are preferred as aluminium is an effective heat conductor.

Approximate solar gains with ordinary float glass ~

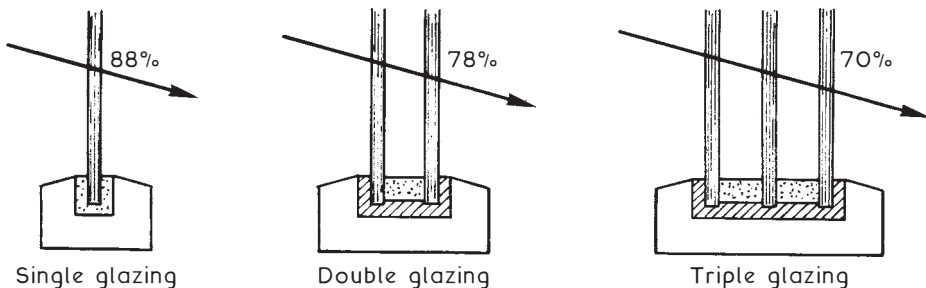

'Low E' invisible coatings reduce the solar gain by up to one-third. Depending on the glass quality and cleanliness, about 10 to 15% of visible light reduction applies for each pane of glass.

# Triple Glazing

Typical application ~

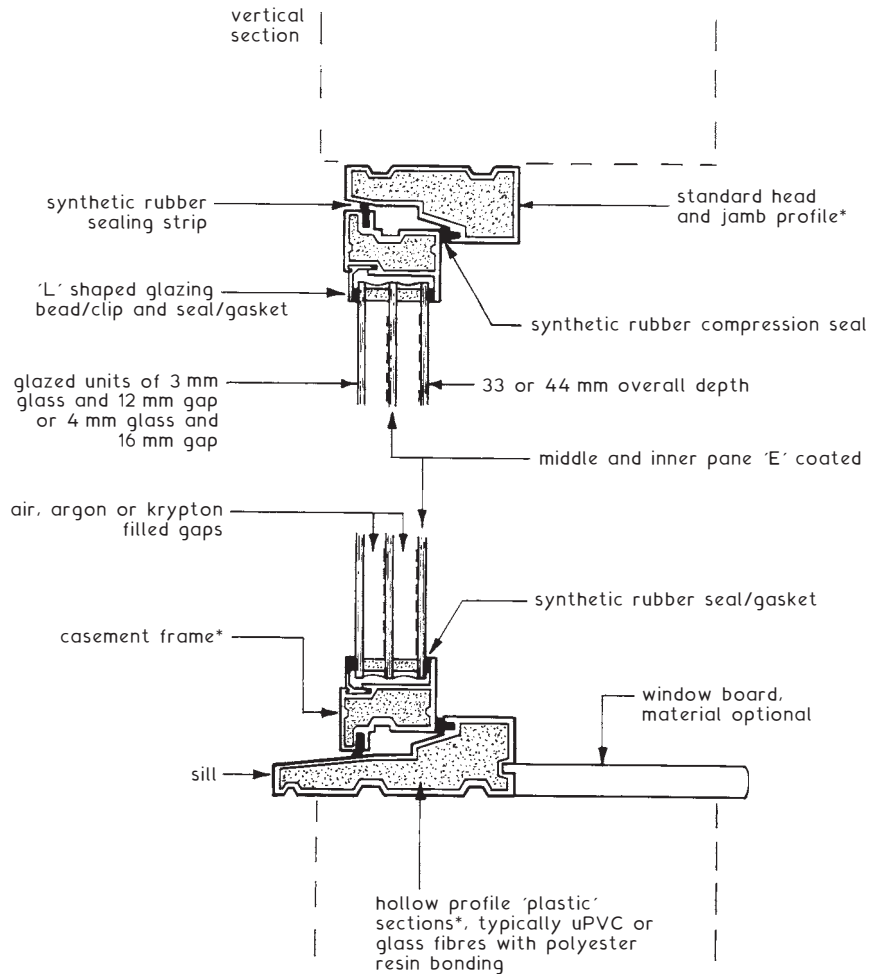

\* Hollow profiles manufactured with a closed cell insulant foam/expanded polystyrene core.

Further considerations:

- \* U-value potential, less than  $1.0 \text{ W/m}^2\text{K}$ .
- \* 'Low E' invisible metallic layer on one pane of double glazing gives a similar insulating value to standard triple glazing (see page 453).
- \* Performance enhanced with blinds between wide gap panes.
- \* High quality ironmongery required due to weight of glazed frames.
- \* Improved sound insulation, particularly with heavier than air gap fill.

## Triple Glazing with Solar Blinds

There are many manufacturers of triple glazed units, each with their own design profile. Some feature a wide gap between two of the glass panes to incorporate Venetian blinds. This type of curtaining is used to control solar radiation and heat gain. Glass specification and thickness may also vary depending on thermal and sound insulation requirements. Blinds can be actuated automatically in response to pre-set thermostatic control or overridden manually.

### Typical Profile ~

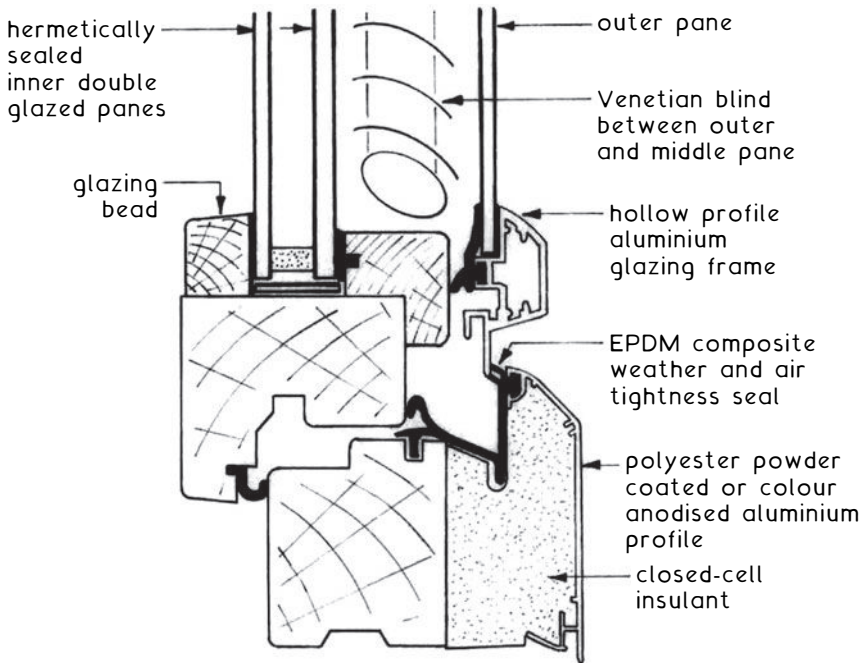

### Potential for Sound Insulation Effectiveness ~

Glazing system	Max. sound reduction (dB)
Single glazed opening sash	20
Single glazed fixed light with weather strips	25
Double glazed, hermetically sealed with weather strips	35
Triple glazed, hermetically sealed, weather strips and blinds	45

Note: These units are considerably heavier than other window types, therefore they will need care in handling during site transportation. The manufacturer's purpose made jamb fixings should be used.

## Glazing – Location

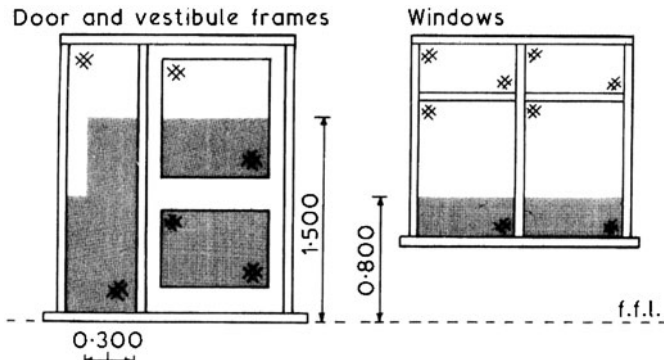

In these critical locations, glazing must satisfy one of the following:

1. Breakage to leave only a small opening with small detachable particles without sharp edges.
2. Disintegrating glass must leave only small detached pieces.
3. Inherent robustness, e.g. polycarbonate composition. Annealed glass acceptable but with the following limitations:

Thickness of annealed glass (mm)	Max. glazed area	
	Height (m)	Width (m)
8	1.100	1.100
10	2.250	2.250
12	3.000	4.500
15	no limit	

4. Panes in small areas, <250mm wide and <0.5 m<sup>2</sup> area. e.g. leaded lights (4 mm annealed glass) and Georgian pattern (6 mm annealed glass).
5. Protective screening as shown with lower bar of screen <75 mm above finished floor level.

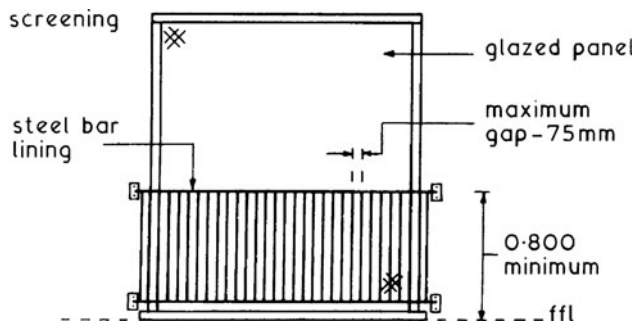

Ref. Building Regulations, A.D. K4: Protection against impact with glazing.

Manifestation or Marking of Glass ~ another aspect of the critical location concept which frequently occurs with contemporary glazed features in a building. Commercial premises such as open plan offices, shops and showrooms often incorporate large walled areas of uninterrupted glass to promote visual depth, whilst dividing space or forming part of the exterior envelope. To prevent collision, glazed doors and walls must have prominent framing or intermediate transoms and mullions. An alternative is to position obvious markings at two levels, as shown below. Glass doors could have large pull/push handles and/or IN and OUT signs in bold lettering. Other areas may be adorned with company logos, stripes, geometric shapes, etc.

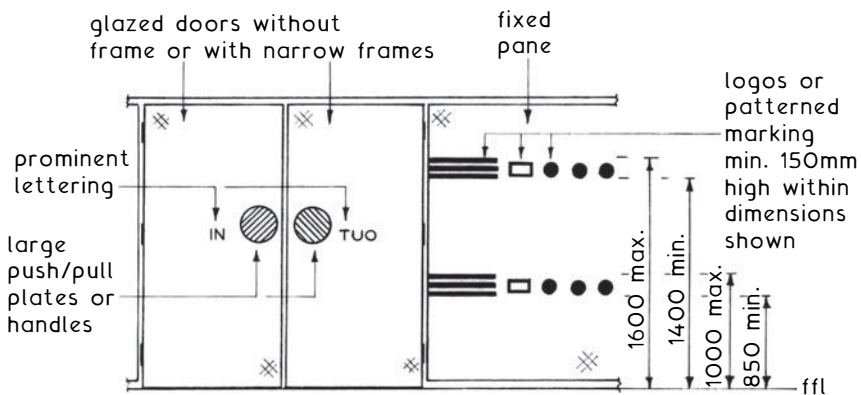

Critical Locations ~ The Building Regulations, Approved Document - K, determines positions where potential personal impact and injury with glazed doors and windows are most critical. In these situations the glazing specification must incorporate a degree of safety such that any breakage would be relatively harmless. Additional measures in British Standard 6206 complement the Building Regulations and provide test requirements and specifications for impact performance for different classes of glazing material. See also BS 6262.

Refs.: Building Regulations, A.D. K5.2: Manifestation of glazing.  
 BS 6206: Specification for impact performance requirements for flat safety glass and safety plastics for use in buildings.  
 BS 6262 series: Glazing for buildings. Codes of practice.



## Glass Block Walling (1)

Glass blocks have been used for some time as internal feature partitioning. They now include a variety of applications in external walls, where they combine the benefits of a walling unit with a natural source of light. They have also been used in paving to allow natural light penetration into basements.

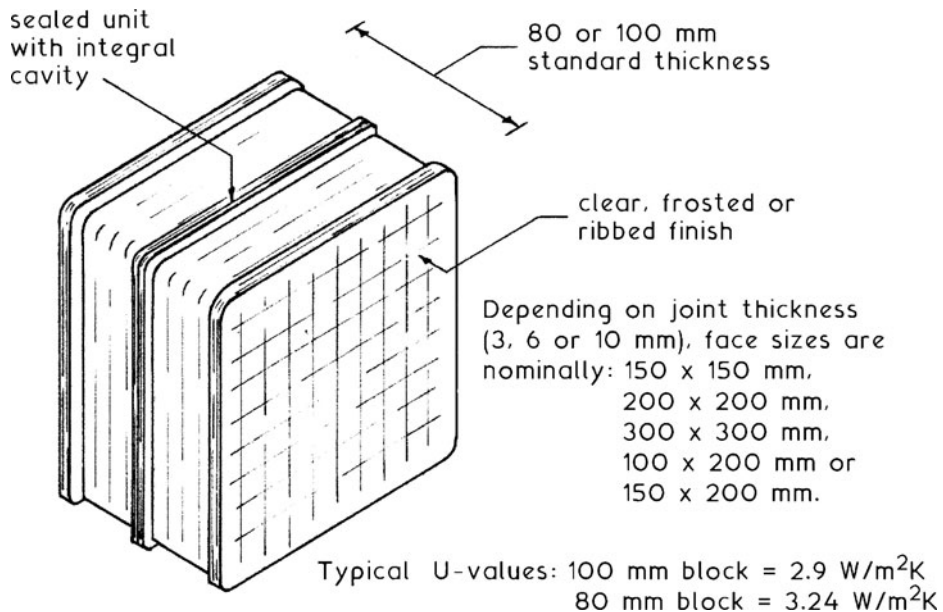

Fire resistance, BS 476-22 - one hour integrity (load bearing capacity and fire containment).

Maximum panel size is 9m<sup>2</sup>. Maximum panel dimension is 3 m.

Laying - glass blocks can be bonded like conventional brickwork, but for aesthetic reasons are usually laid with continuous vertical and horizontal joints.

Jointing - blocks are bedded in mortar with reinforcement from two nine-gauge galvanised steel wires in horizontal joints. Every third course for 150 mm units, every second course for 200 mm units and every course for 300 mm units. First and last course to be reinforced.

Ref.: BS 476-22: Fire tests on building materials and structures. Methods for determination of the fire resistance of non-load-bearing elements of construction.

Mortar - dryer than for bricklaying as the blocks are non-absorbent. The general specification will include: White Portland Cement (BS EN 197-1), High Calcium Lime (BS EN 459-1) and Sand. The sand should be white quartzite or silica type. Fine silver sand is acceptable. An integral waterproofing agent should also be provided. Recommended mix ratios - 1 part cement: 0.5 part lime: 4 parts sand.

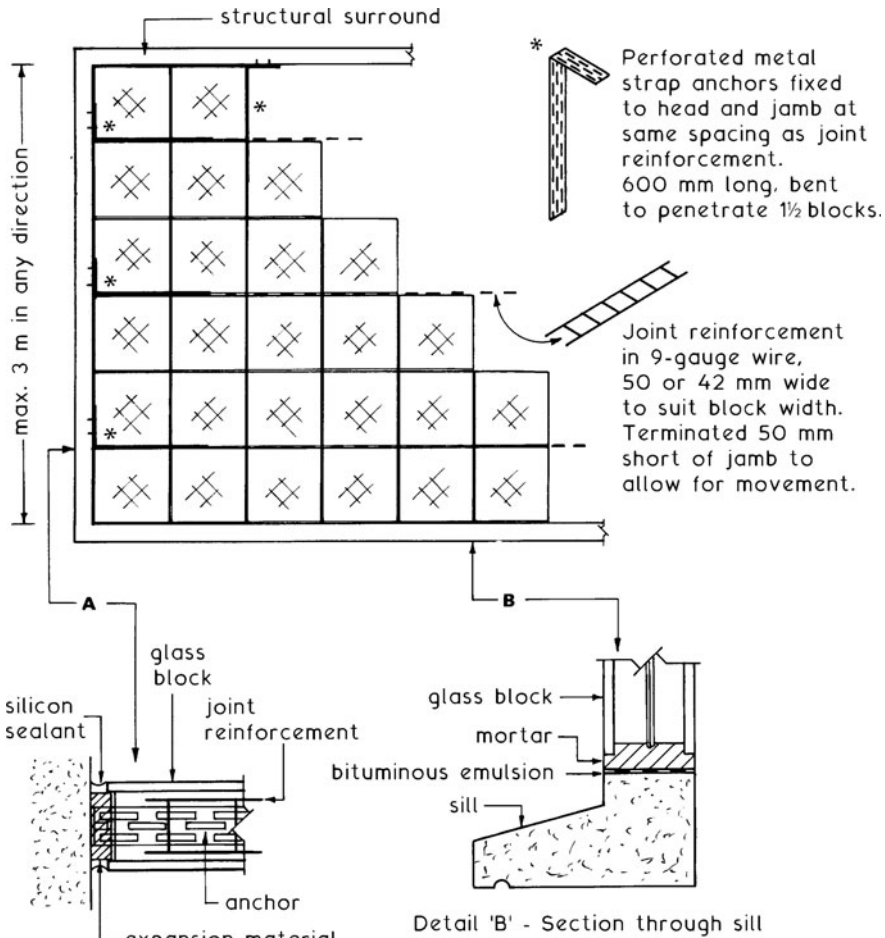

Detail 'A' - Section through jamb  
NB. Same detail for head, except omit reinforcement.

Ref. BS EN 1051-1: Glass in building. Glass blocks and glass pavers. Definitions and description.

## Doors – Performance Requirements

Doors ~ can be classed as external or internal. External doors are usually thicker and more robust in design than internal doors since they have more functions to fulfil.

Typical Functions ~

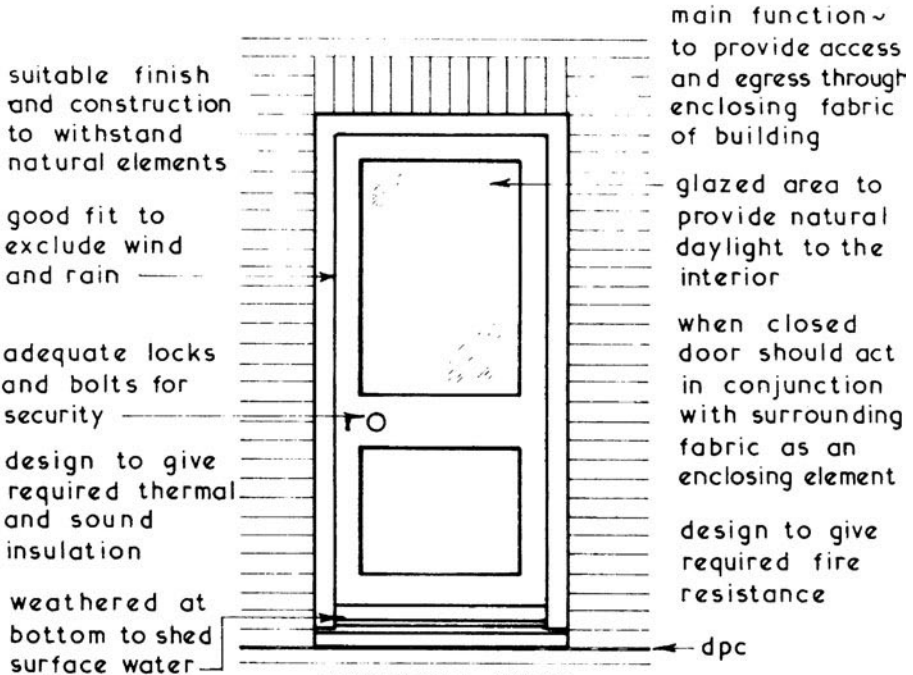

EXTERNAL DOOR

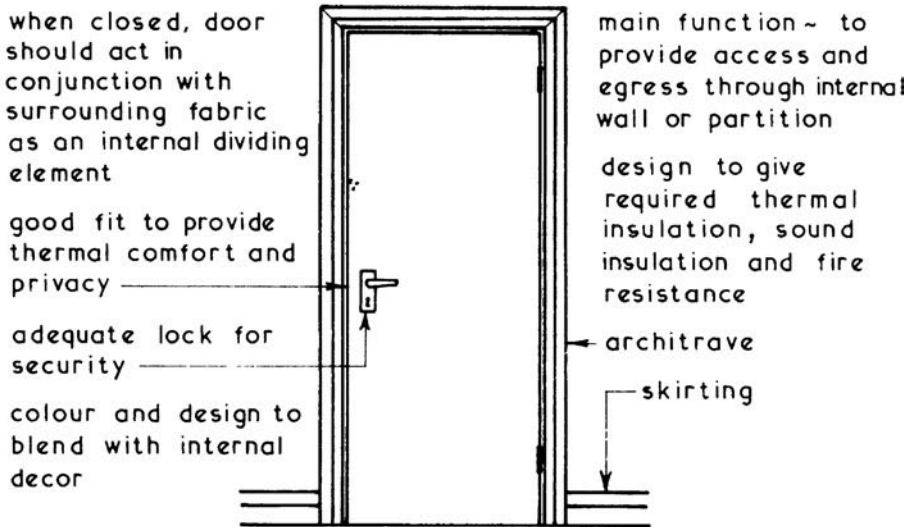

INTERNAL DOOR

External Doors ~ these are available in a wide variety of types and styles in timber, aluminium alloy or steel. The majority of external doors are however made from timber, the metal doors being mainly confined to fully glazed doors such as 'patio doors'.

Typical Examples of External Doors ~

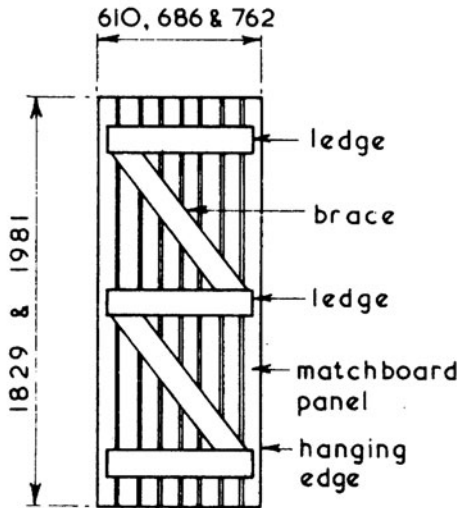

LEDGED AND BRACED DOOR

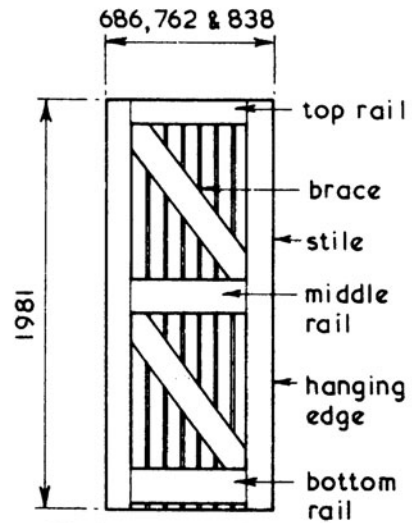

FRAMED LEDGED AND BRACED DOOR

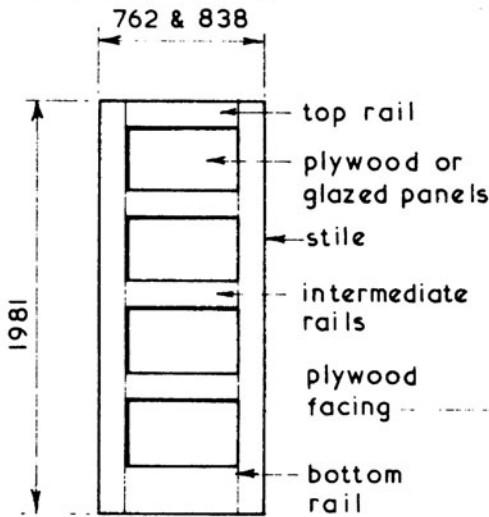

1, 2, 3 OR 4 PANELLED DOORS

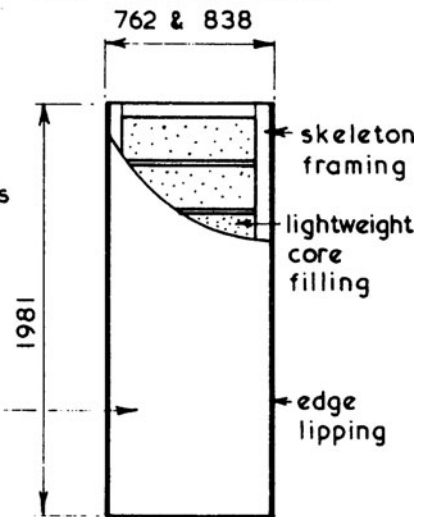

FLUSH DOORS

# Door Types

Typical examples of purpose made and non-standard external doors ~

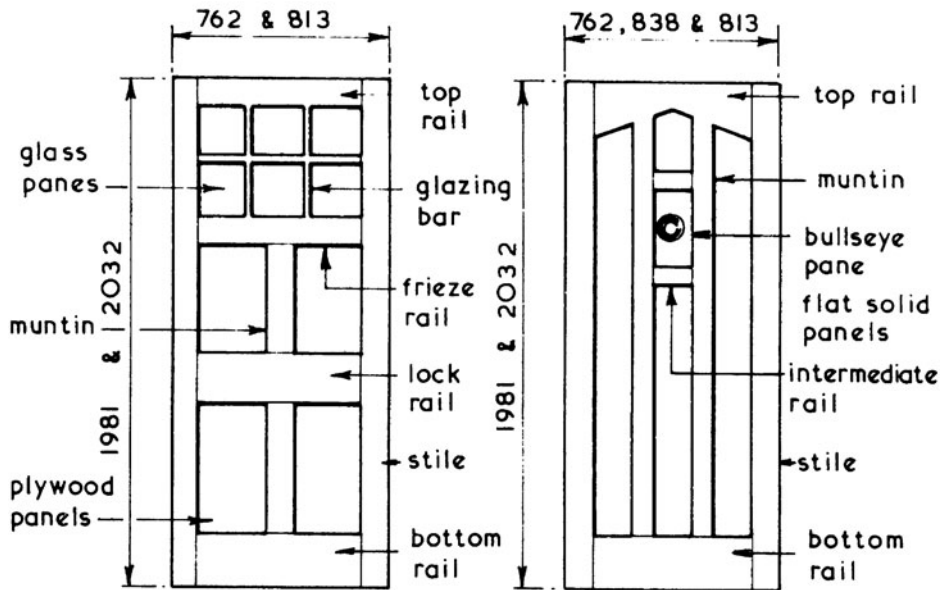

PURPOSE MADE

TUDOR STYLE

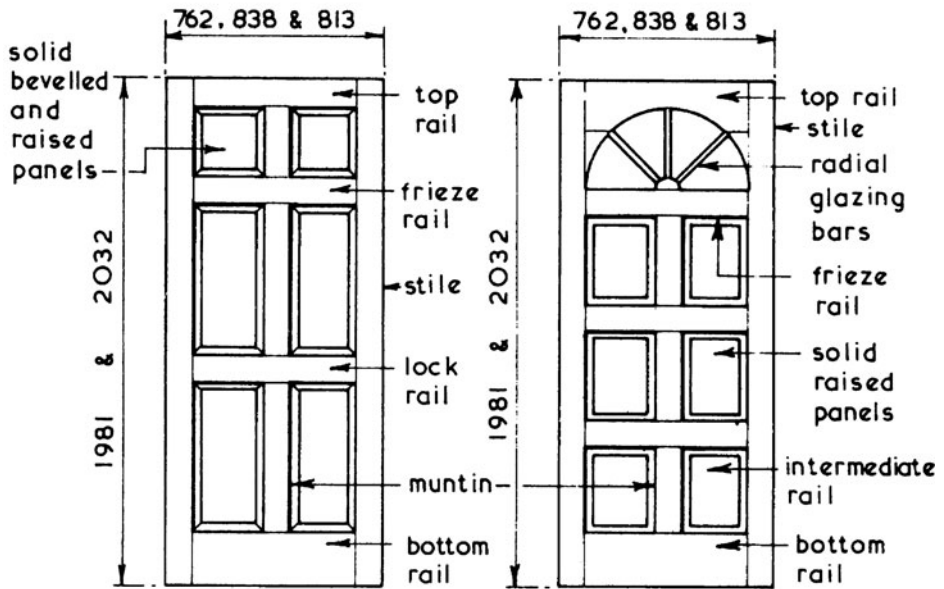

GEORGIAN STYLE

PURPOSE MADE

Door Frames ~ these are available for all standard external doors and can be obtained with a fixed solid or glazed panel above a door height transom. Door frames are available for doors opening inwards or outwards. Most door frames are made to the recommendations set out in BS 4787: Internal and external wood doorsets, door leaves and frames. Specification for dimensional requirements.

Typical Example ~

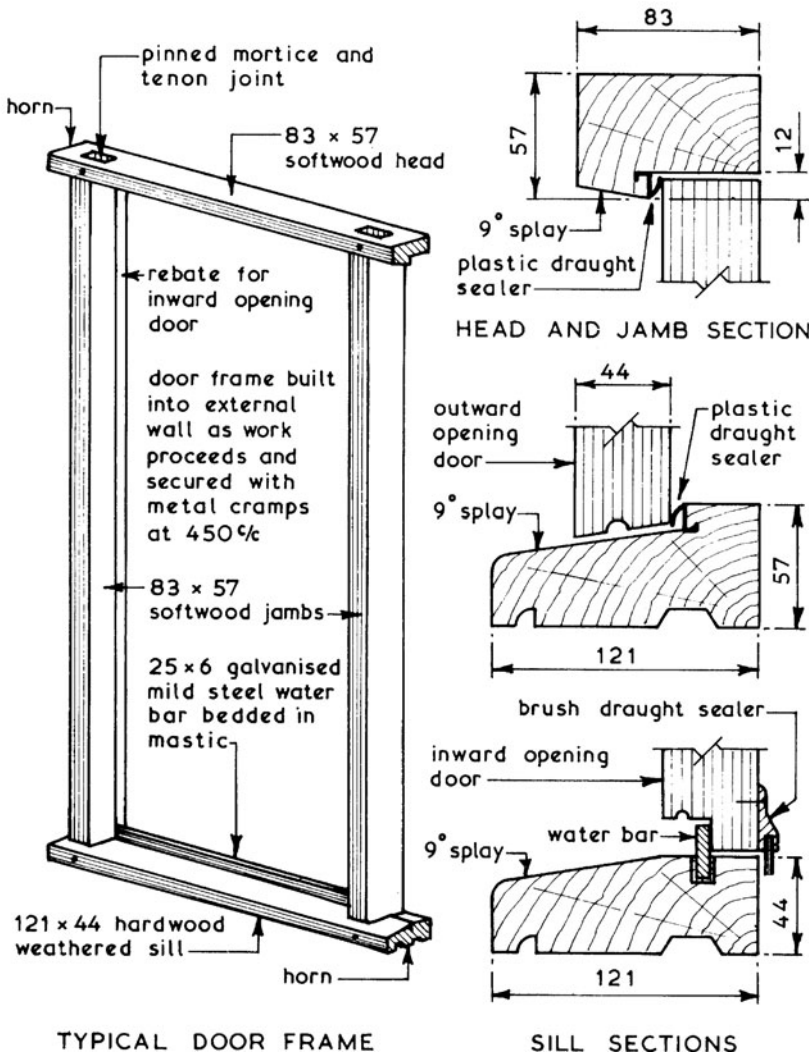

# Door Ironmongery

Door Ironmongery ~ available in a wide variety of materials, styles and finishers but will consist of essentially the same components:

Hinges or Butts - these are used to fix the door to its frame or lining and to enable it to pivot about its hanging edge.

Locks, Latches and Bolts ~ the means of keeping the door in its closed position and providing the required degree of security. The handles and cover plates used in conjunction with locks and latches are collectively called door furniture.

Letter Plates - fitted in external doors to enable letters, etc. to be deposited through the door.

Other items include Finger and Kicking Plates which are used to protect the door fabric where there is high usage.

Draught Excluders to seal the clearance gap around the edges of the door and Security Chains to enable the door to be partially opened and thus retain some security.

## Typical Examples ~

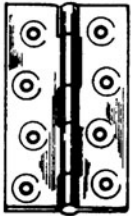

**BUTT HINGE**  
available in  
steel, brass,  
nylon and  
aluminium

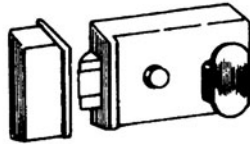

**RIM NIGHT LATCH**  
fitted on internal face



**LETTER PLATE**  
can be obtained with  
an integral knocker

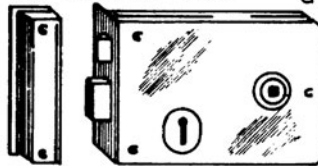

**RIM LOCK**  
fitted on internal face



**BARREL BOLT**  
available in steel,  
brass and aluminium

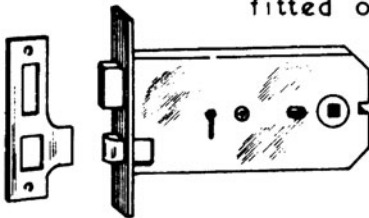

**MORTICE LOCK**  
fitted within body of door

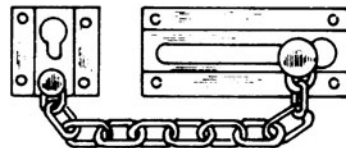

**SECURITY DOOR CHAIN**  
extruded brass with welded  
brassed steel chain

Industrial Doors ~ these doors are usually classified by their method of operation and construction. There is a very wide range of doors available and the choice should be based on the following considerations:

1. Movement - vertical or horizontal.
2. Size of opening.
3. Position and purpose of door(s).
4. Frequency of opening and closing door(s).
5. Manual or mechanical operation.
6. Thermal and/or sound insulation requirements.
7. Fire resistance requirements.

Typical Industrial Door Types ~

1. Straight Sliding -

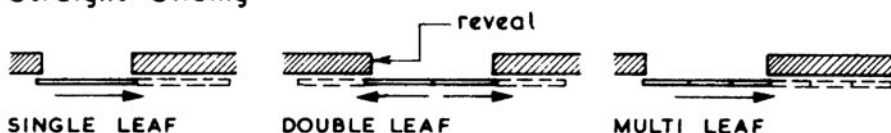

These types can be top hung with a bottom guide roller or hung with bottom rollers and top guides - see page 468

2 Sliding / Folding -

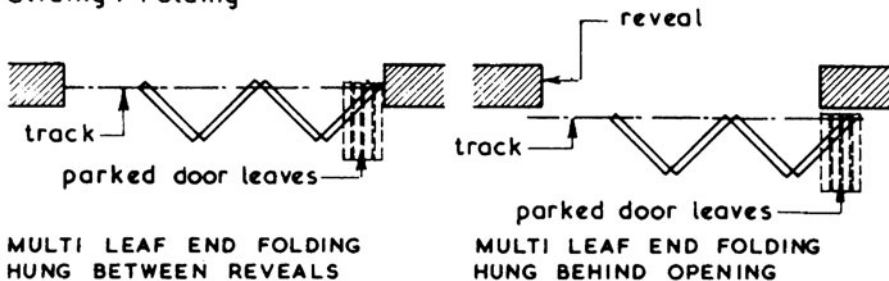

These types can be top hung with a bottom guide roller or hung with bottom rollers and top guides - see page 469

3. Shutters -

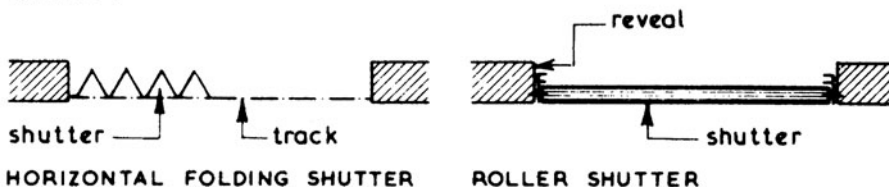

Shutters can be installed between, behind or in front of the reveals - see page 470



# Industrial Doors

Straight Sliding Doors ~ these doors are easy to operate, economic to maintain and present no problems for the inclusion of a wicket gate. They do however take up wall space to enable the leaves to be parked in the open position. The floor guide channel associated with top hung doors can become blocked with dirt, causing a malfunction of the sliding movement, whereas the rollers in bottom track doors can seize up unless regularly lubricated and kept clean. Straight sliding doors are available with either manual or mechanical operation.

Typical Example ~

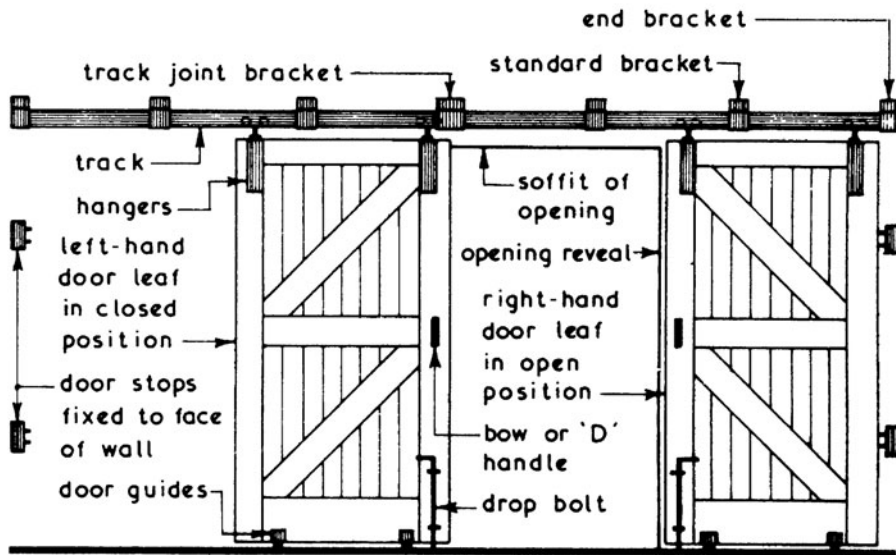

ELEVATION

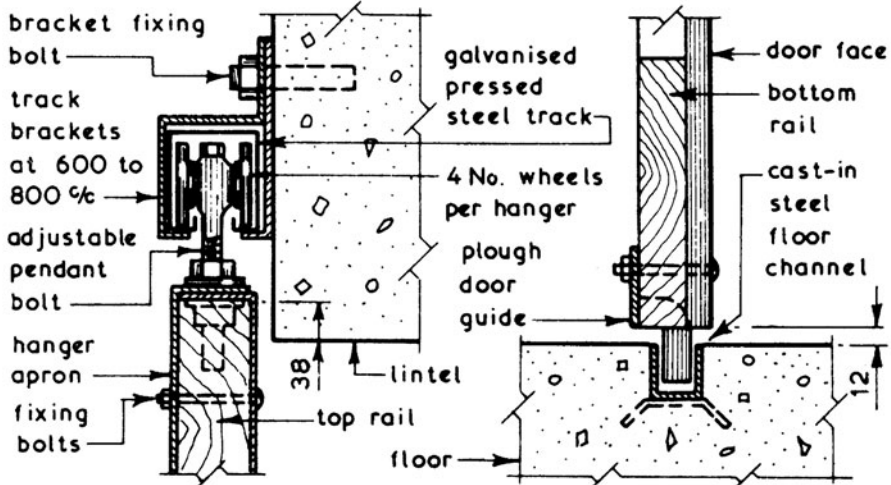

Sliding/Folding Doors ~ these doors are an alternative format to the straight sliding door types and have the same advantages and disadvantages except that the parking space required for the opened door is less than that for straight sliding doors. Sliding/folding are usually manually operated and can be arranged in groups of two to eight leaves.

Typical Example ~

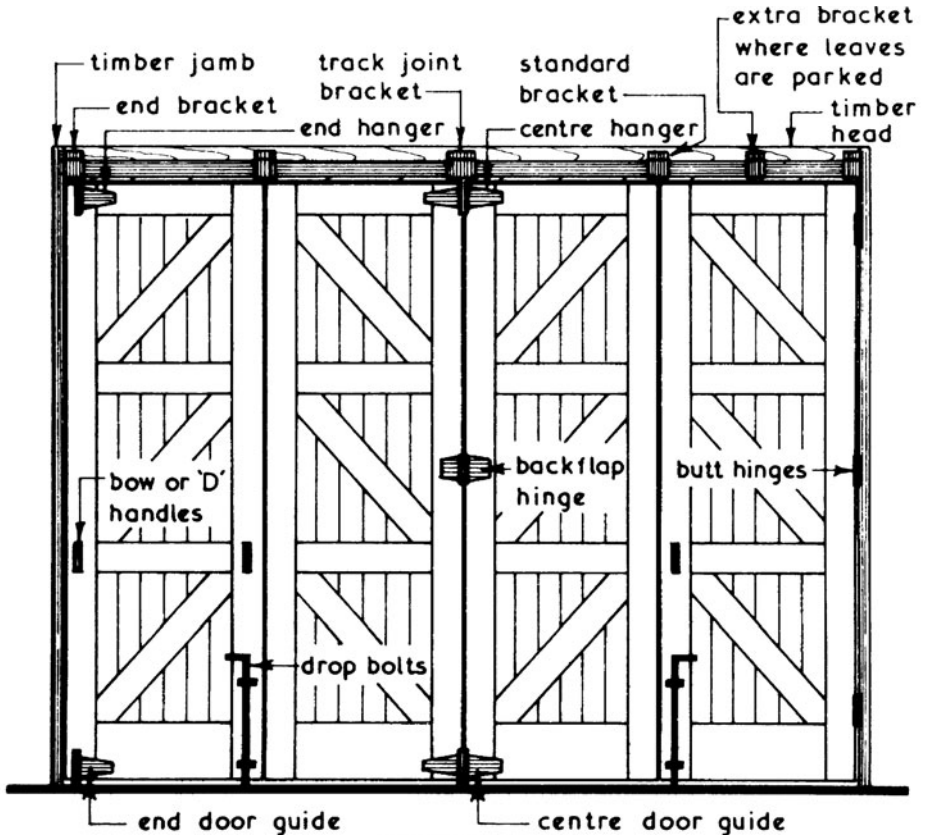

ELEVATION

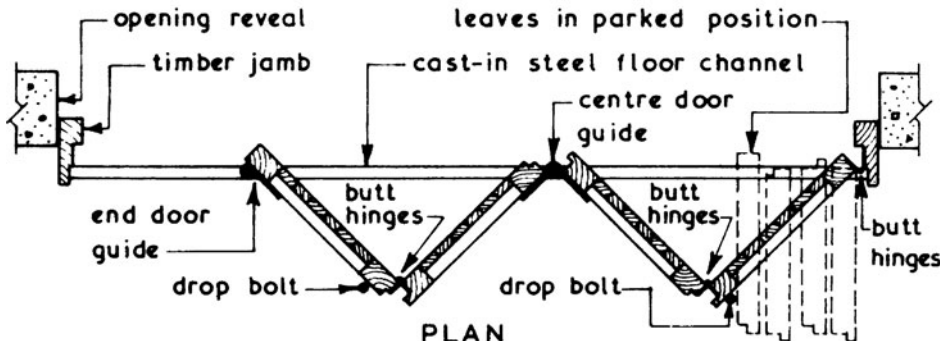

PLAN

Shutters ~ horizontal folding shutters are similar in operation to sliding/folding doors but are composed of smaller leaves and present the same problems. Roller shutters however do not occupy any wall space but usually have to be fully opened for access. They can be manually operated by means of a pole when the shutters are self-coiling, operated by means of an endless chain winding gear or mechanically raised and lowered by an electric motor but in all cases they are slow to open and close. Vision panels cannot be incorporated into the roller shutter but it is possible to include a small wicket gate or door in the design.

Typical Details ~

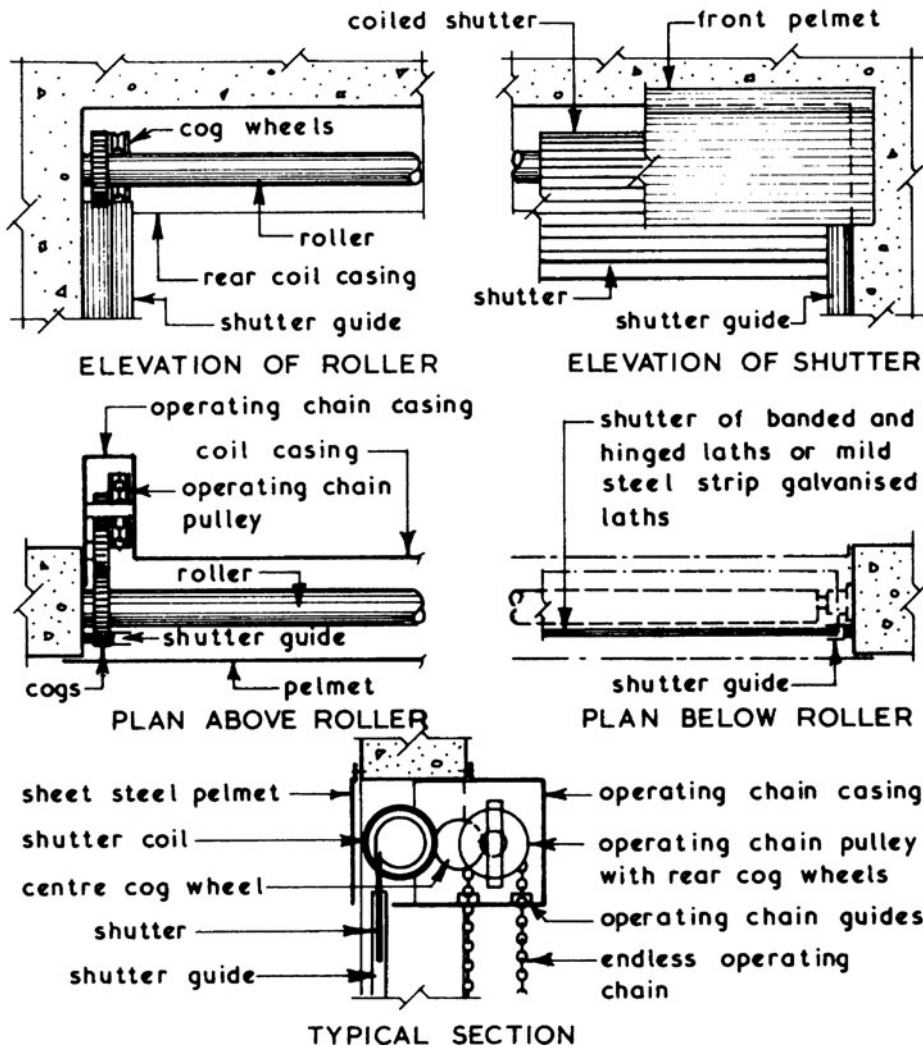

Crosswall Construction ~ this is a form of construction where load bearing walls are placed at right angles to the lateral axis of the building, the front and rear walls being essentially non-load bearing cladding. Crosswall construction is suitable for buildings of up to five storeys high where the floors are similar and where internal separating or party walls are required such as in blocks of flats or maisonettes. The intermediate floors span longitudinally between the crosswalls providing the necessary lateral restraint and if both walls and floors are of cast in-situ reinforced concrete the series of 'boxes' so formed is sometimes called box frame construction. Great care must be taken in both design and construction to ensure that the junctions between the non-load bearing claddings and the crosswalls are weather tight. If a pitched roof is to be employed with the ridge parallel to the lateral axis an edge beam will be required to provide a seating for the trussed or common rafters and to transmit the roof loads to the crosswalls.

## Typical Crosswall Arrangement Details ~

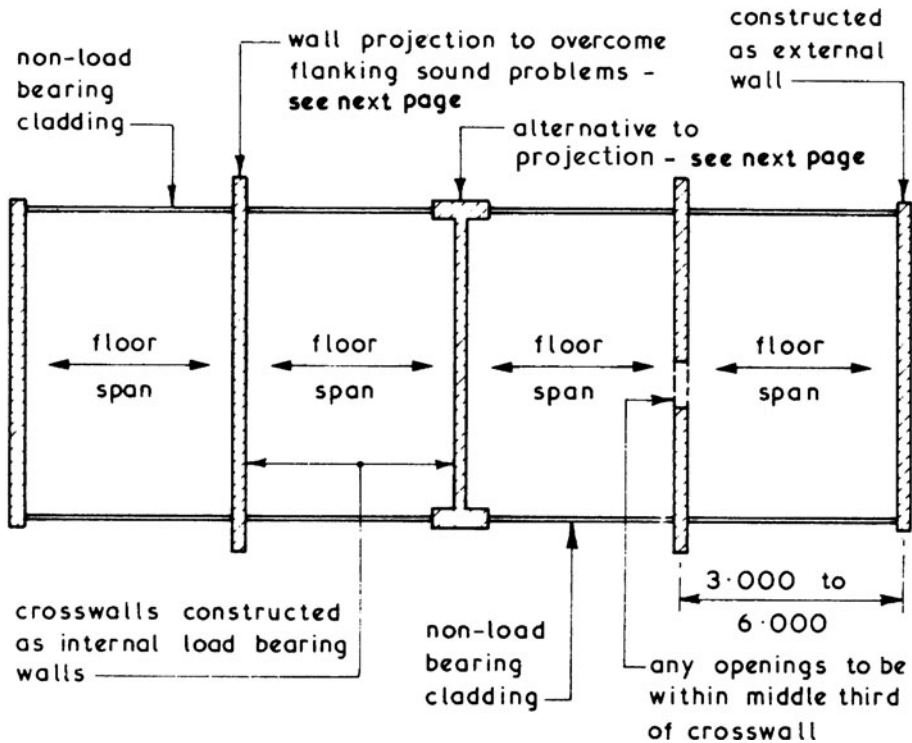

# Crosswall Construction

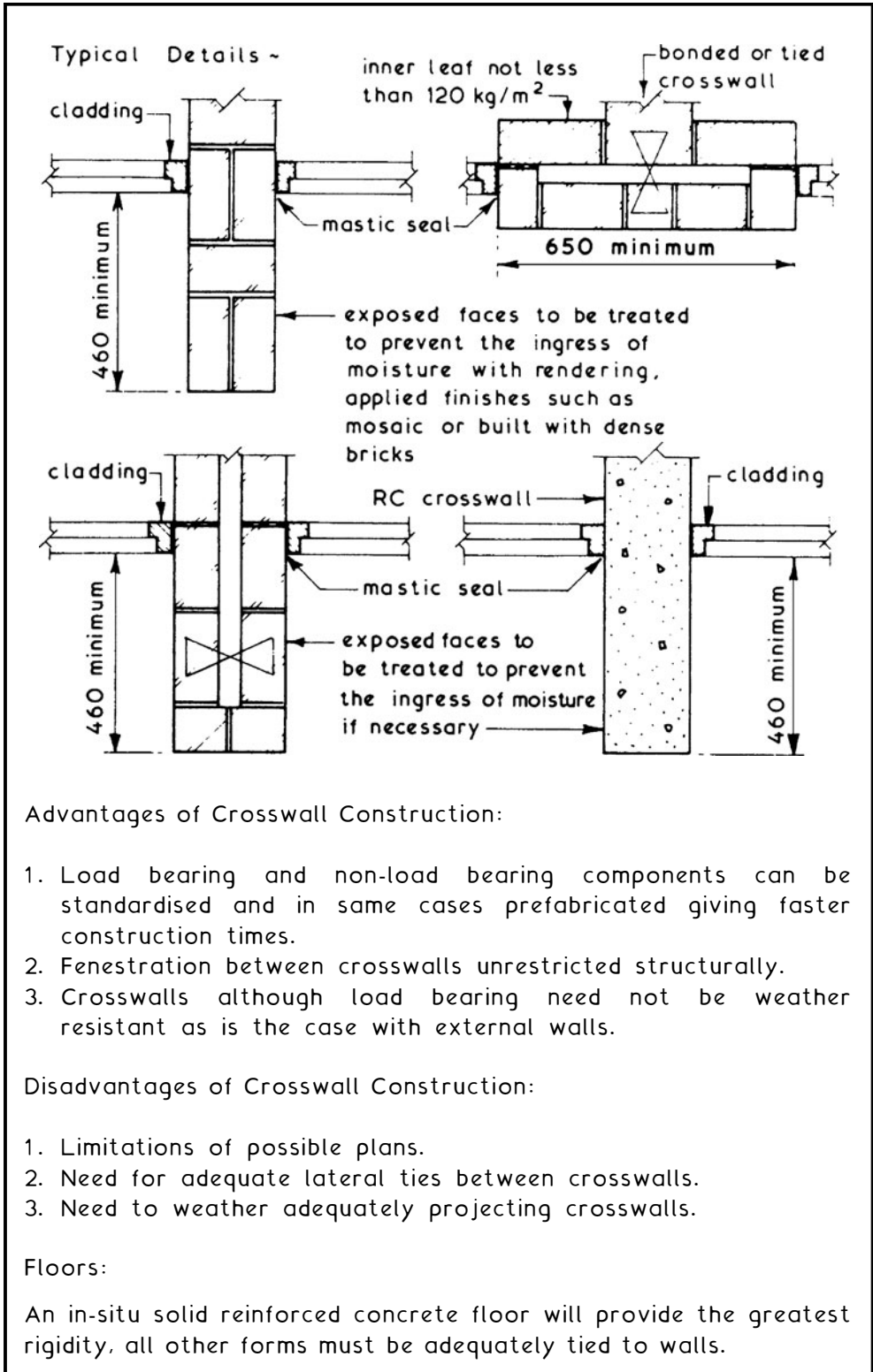

## Advantages of Crosswall Construction:

1. Load bearing and non-load bearing components can be standardised and in some cases prefabricated giving faster construction times.
2. Fenestration between crosswalls unrestricted structurally.
3. Crosswalls although load bearing need not be weather resistant as is the case with external walls.

## Disadvantages of Crosswall Construction:

1. Limitations of possible plans.
2. Need for adequate lateral ties between crosswalls.
3. Need to weather adequately projecting crosswalls.

## Floors:

An in-situ solid reinforced concrete floor will provide the greatest rigidity, all other forms must be adequately tied to walls.

## Crosswall Construction – Precast Concrete

System ~ comprises quality controlled factory produced components of plain reinforced concrete walls and prestressed concrete hollow or solid core plank floors.

Site Assembly ~ components are crane lifted and stacked manually with the floor panel edges bearing on surrounding walls. Temporary support will be necessary until the units are 'stitched' together with horizontal and vertical steel reinforcing ties located through reinforcement loops projecting from adjacent panels. In-situ concrete completes the structural connection to provide full transfer of all forces and loads through the joint. Precast concrete stair flights and landings are located and connected to support panels by steel angle bracketing and in-situ concrete joints.

Typical 'stitched' joint between precast concrete crosswall components ~

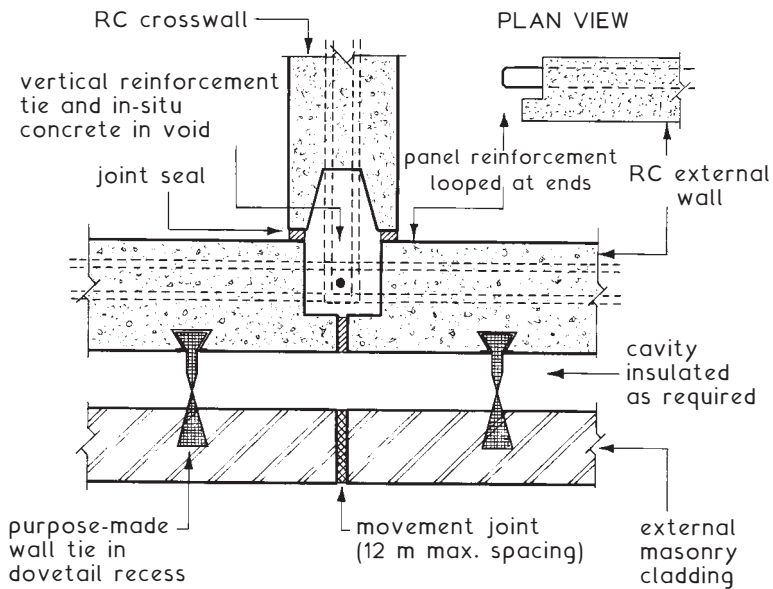

## Crosswall Construction – Precast Concrete

Concept ~ a cost-effective simple and fast site assembly system using load-bearing partitions and external walls to transfer vertical loads from floor panels. The floor provides lateral stability by diaphragm action between the walls.

Application ~ precast reinforced concrete crosswall construction systems may be used to construct multi-storey buildings, particularly where the diaphragm floor load distribution is transferred to lift or stair well cores. Typical applications include schools, hotels, hostels, apartment blocks and hospitals. External appearance can be enhanced by a variety of cladding possibilities, including the traditional look of face brickwork secured to the structure by in-built ties. Internal finishing may be with paint or plaster, but it is usually dry lined with plasterboard.

Location of 'stitched' in-situ reinforced concrete ties ~

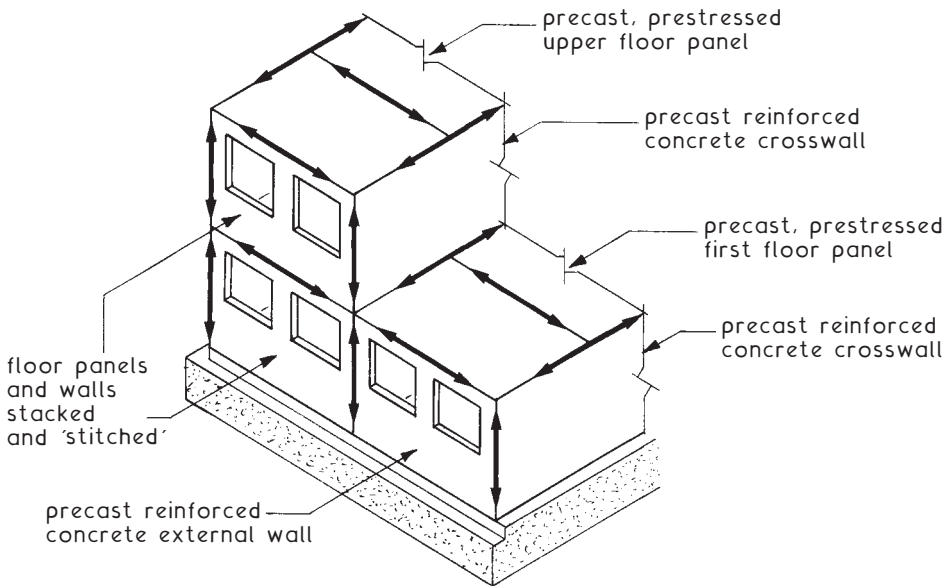

Fire resistance and sound insulation are achieved by density and quality of concrete. The thermal mass of concrete can be enhanced by applying insulation in between the external precast panel and the masonry or other cladding.

Framing ~ an industry-based prefabricated house manufacturing process permitting rapid site construction, with considerably fewer site operatives than traditional construction. This technique has a long history of conventional practice in Scandinavia and North America, but has only gained credibility in the UK since the 1960s. Factory-made panels are based on a stud framework of timber, normally ex. 100 × 50 mm, an outer sheathing of plywood, particle-board or similar sheet material, insulation between the framing members and an internal lining of plasterboard. An outer cladding of brickwork weatherproofs the building and provides a traditional appearance.

Assembly techniques are derived from two systems:

1. Balloon frame
2. Platform frame

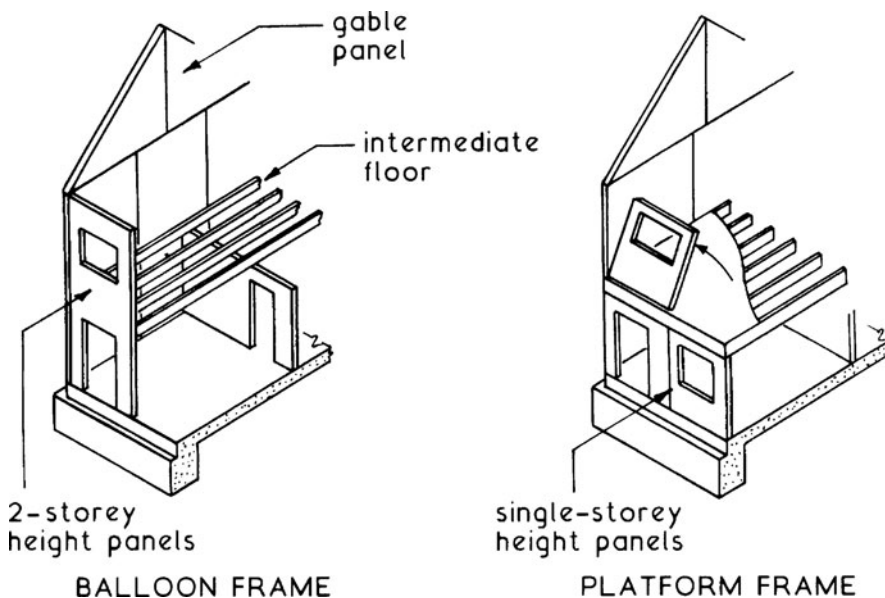

A balloon frame consists of two-storey height panels with an intermediate floor suspended from the framework. In the UK, the platform frame is preferred with intermediate floor support directly on the lower panel. It is also easier to transport, easier to handle on site and has fewer shrinkage and movement problems.



# Timber Frame Construction

## Typical Details ~

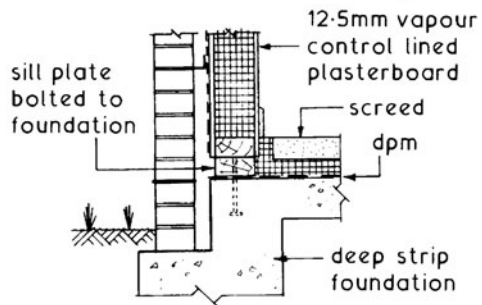
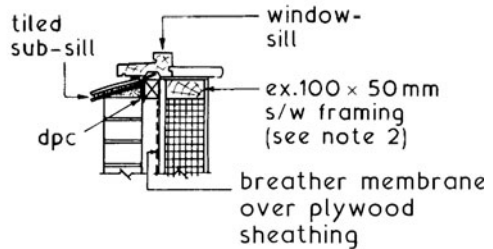
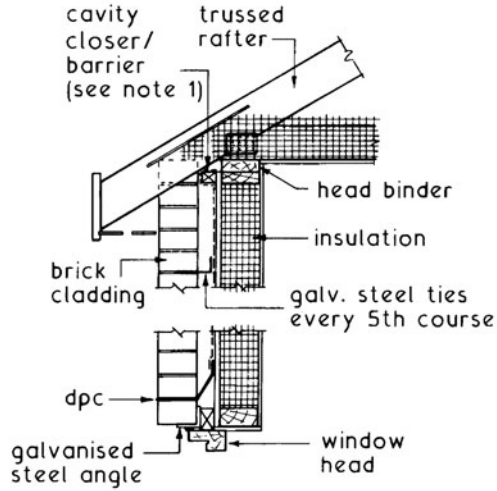
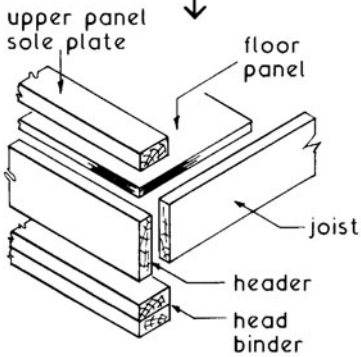
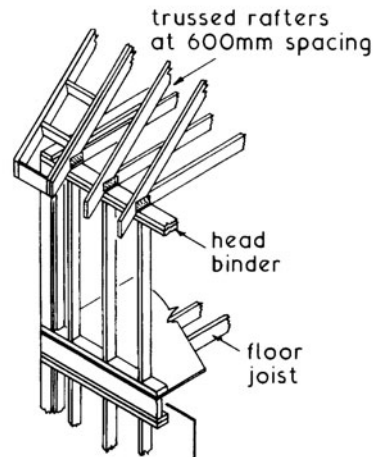

### Notes:

1. Cavity barriers prevent fire spread. The principal locations are between elements and compartments of construction (see B. Regs. A.D. B3).
2. Thermal bridging through solid framing may be reduced by using rigid EPS insulation and lighter 'I' section members of plywood or oriented strand board (OSB).

Framing ~ comprising inner leaf wall panels of standard cold-formed galvanised steel channel sections as structural support, with a lined inner face of vapour check layer under plasterboard. These panels can be site assembled, but it is more realistic to order them factory made. Panels are usually produced in 600 mm wide modules and bolted together on site. Roof trusses are made up from steel channel or sigma sections. See page 628 for examples of standard steel sections and BS EN 10162: Cold rolled steel sections.

Standard channel and panel.

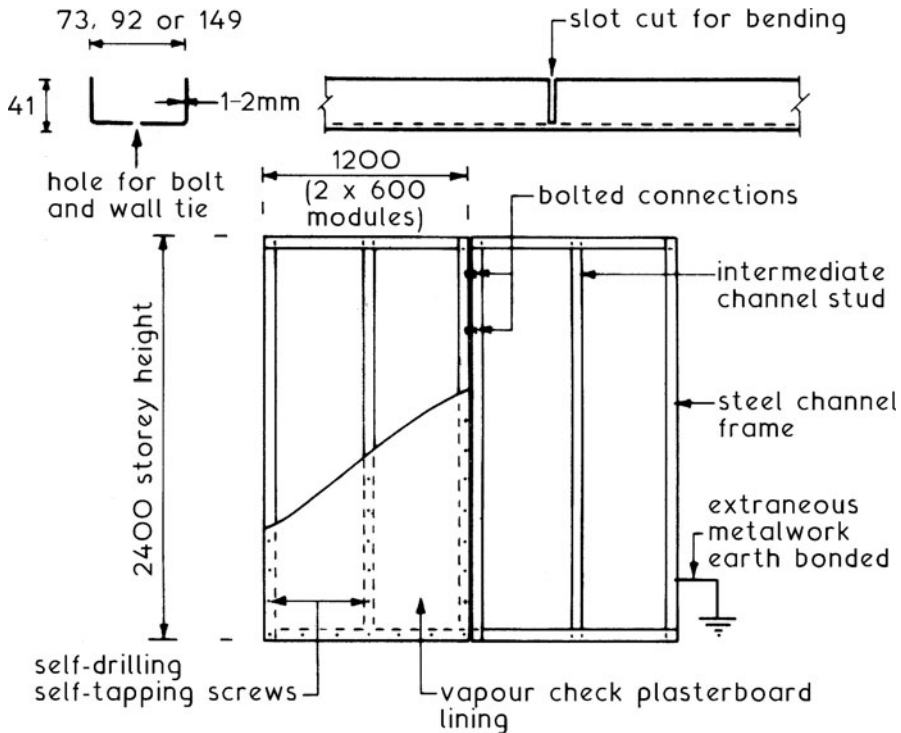

Background/history ~ the concept of steel framing for house construction evolved in the early 1920s, but development of the lightweight concrete 'breeze' block soon took preference. Due to a shortage of traditional building materials, a resurgence of interest occurred again during the early post-war building boom of the late 1940s. Thereafter, steel became relatively costly and uncompetitive as a viable alternative to concrete block or timber frame construction techniques. Since the 1990s more efficient factory production processes, use of semi-skilled site labour and availability of economic cold-formed sections have revived an interest in this alternative means of house construction.

# Steel Frame Construction (2)

## Typical Details ~

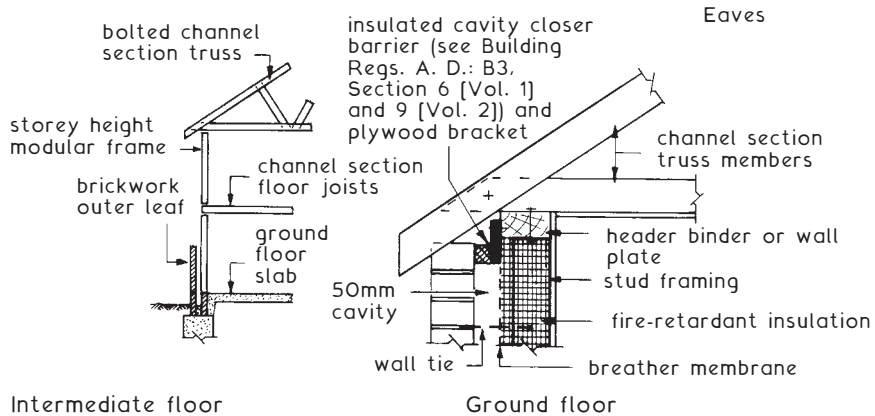

### Advantages:

- Factory made, therefore produced to quality controlled standards and tolerances.
- Relatively simple to assemble on site - bolted connections in preformed holes.
- Dimensionally stable, consistent composition, insignificant movement.
- Unaffected by moisture, therefore will not rot.
- Does not burn.
- Inedible by insects.
- Roof spans potentially long relative to weight.

### Disadvantages:

- Possibility of corrosion if galvanised protective layer is damaged.
- Deforms at high temperature, therefore unpredictable in fire.
- Electricity conductor - must be earthed.

## Rendering to External Walls – Mix and Background

Render ~ a mix of binder (cement) and fine aggregate (sand) with the addition of water and lime or a plasticiser to make the mix workable. Applied to walls as a decorative and/or waterproofing treatment.

Mix ratios ~ for general use, mix ratios are between 1:0.5:4-4.5 and 1:1:5-6 of cement, lime and sand. Equivalent using masonry cement and sand is 1:2.5-3.5 and 1:4-5. Unless a fine finish is required, coarse textured sharp sand is preferred for stability.

Background ~

Masonry – brick and block-work joints raked out 12 to 15 mm to provide a key for the first bonding coat. Metal mesh can be nailed to the surface as supplementary support and reinforcing.

Wood or similar sheeting – metal lathing, wire mesh or expanded metal of galvanised (zinc coated) or stainless steel secured every 300 mm. A purpose-made lathing is produced for timber-framed walls.

Concrete – and other smooth, dense surfaces can be hacked to provide a key or spatter-dashed. Spatter-dash is a strong mix of cement and sand (1:2) mixed into a slurry, trowelled roughly or thrown on to leave an irregular surface as a key to subsequent applications.

Three coat application to a masonry background

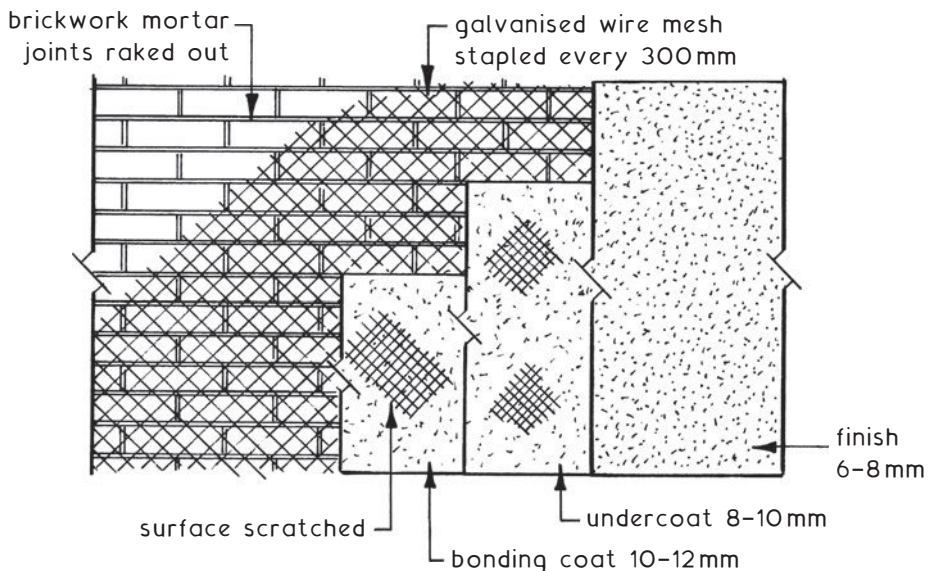

## Rendering to External Walls – Layers and Finishes

Number of coats (layers) and composition ~ in sheltered locations, one 10 mm layer is adequate for regular backgrounds. Elsewhere, two or possibly three separate applications are required to adequately weatherproof the wall and to prevent the brick or block-work joints from 'grinning' through. Render mixes should become slightly weaker towards the outer layer to allow for greater flexure at the surface, i.e. less opportunity for movement and shrinkage cracking.

Finishes ~ smooth, textured, rough-cast and pebble-dashed.

Smooth – fine sand and cement finished with a steel trowel (6 to 8 mm).

Textured – final layer finished with a coarse brush, toothed implement or a fabric roller (10 to 12 mm with 3 mm surface treated).

Rough-cast – irregular finish resulting from throwing the final coat onto the wall (6 to 10 mm).

Pebble or dry dash – small stones thrown onto a strong mortar finishing coat (10 to 12 mm).

Render application to a timber framed background

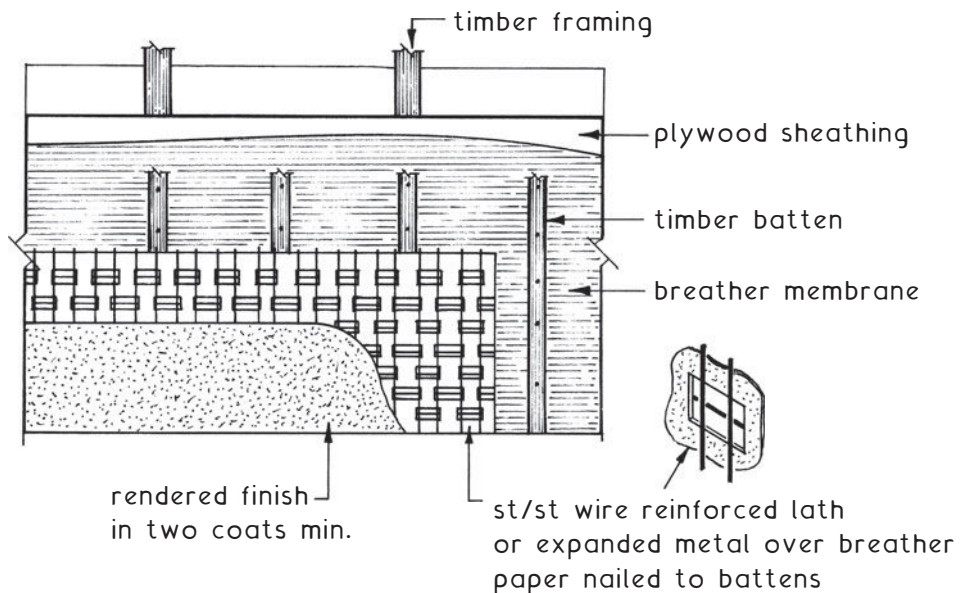

Ref. BS EN 13914 – 1: Design, preparation and application of external rendering and internal plastering. External rendering.

Traditional renders ~ a site-mixed sand base with a cement and/or lime binder combined with water to produce a workable mix. Mostly used to cover poor quality or inexpensive backgrounds, producing a reasonably waterproof outer surface for decorative treatment. Can also be a design choice.

Polymer modified renders ~ delivered to site in factory-premixed 20 or 25kg bags for the addition of water prior to application. Recipes vary, but in principle manufacturers combine polymeric additives with the base materials of sand and cement. These may include latexes or emulsions, water soluble polymer powders and resins. Polyvinyl acetate (PVA) is the synthetic adhesive generally used. PVA is more commonly known as a wood glue, but in modified renders it functions as an emulsion in water to partially replace cement. Some products also include anti-crack fibres as a reinforcement.

Background ~ existing or newly constructed substrate of render, masonry, concrete, timber or insulation slab (see page 576). Must be sound, reasonably level, free of friable material, algae, lichens and any other surface growths. A fungicidal wash and stabilising solution/primer can be applied to control surface suction.

Application ~ two-coat work for irregular surfaces and refurbishment. 8-10mm base coat reinforced with galvanised or stainless steel mesh secured to the wall. Woven glass-fibre mesh can also be used, generally embedded in the base coat over existing cracks or damaged areas.

Finish ~ 6-8mm over scratched base coat. Surface treatments as described for traditional renders.

Properties ~

- Enhanced weatherproofing.

- Vapour permeable.

- Good resistance to impact.

- Inherent adhesion.

- Consistent mix produced in quality controlled factory conditions.

- Suitable for a variety of backgrounds.

## Cladding to External Walls

Claddings to External Walls ~ external walls of block or timber frame construction can be clad with tiles, timber boards or plastic board sections. The tiles used are plain roofing tiles with either a straight or patterned bottom edge. They are applied to the vertical surface in the same manner as tiles laid on a sloping surface (see pages 504 and 507) except that the gauge can be wider and each tile is twice nailed. External and internal angles can be formed using special tiles or they can be mitred. Timber boards such as matchboarding and shiplap can be fixed vertically to horizontal battens or horizontally to vertical battens. Plastic moulded board claddings can be applied in a similar manner. The battens to which the claddings are fixed should be treated with a preservative against fungi and beetle attack and should be fixed with corrosion resistant nails.

Typical Details ~

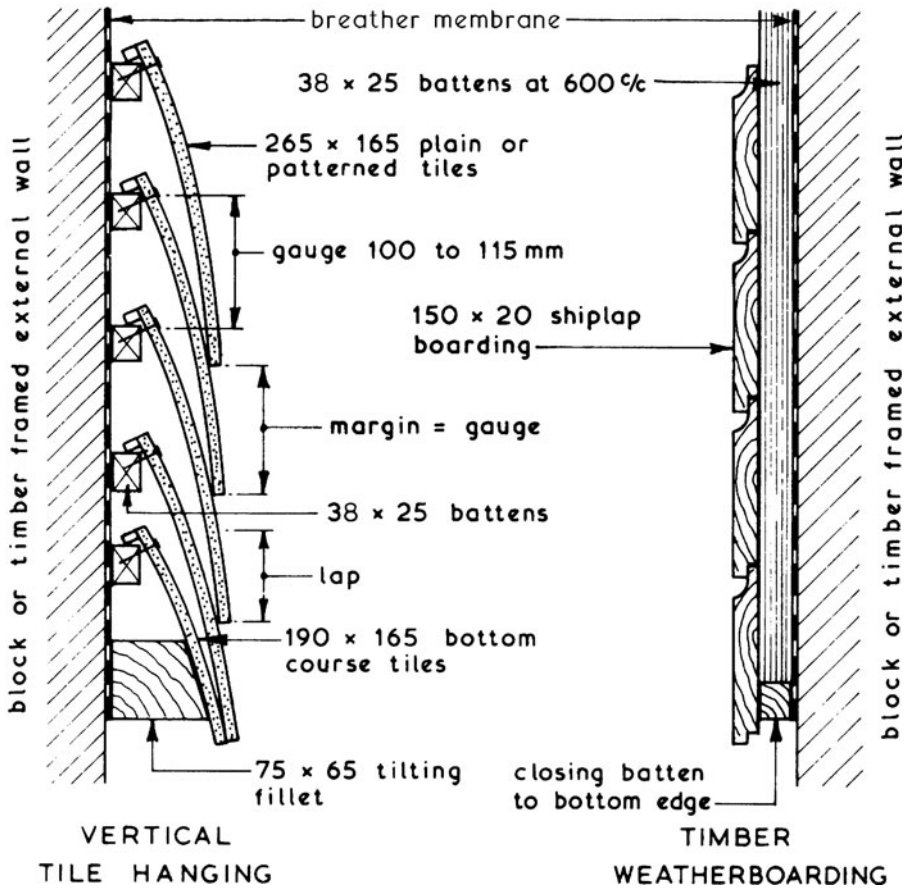

Shrinkage ~ timber is subject to natural movement (page 148). With slender cladding sections allowance must be made to accommodate this by drying to an appropriate moisture content before fixing, otherwise gaps will open between adjacent boards.

Fixing ~ round head galvanised or stainless steel nails will avoid corrosion and metal staining. Lost head nails should be avoided as these can pull through. Annular ring shank nails provide extra grip. Pneumatic gun fixing to be applied with care to ensure no surface damage from impact. Nail length to penetrate the support battens by at least 22 mm. Two and a half times board thickness is usually specified. Dense timbers such as Siberian larch, Douglas fir and hardwoods should be pre-drilled 2 mm over nail diameter. Double nailing may be required in very exposed situations.

Various Timber Cladding Profiles ~

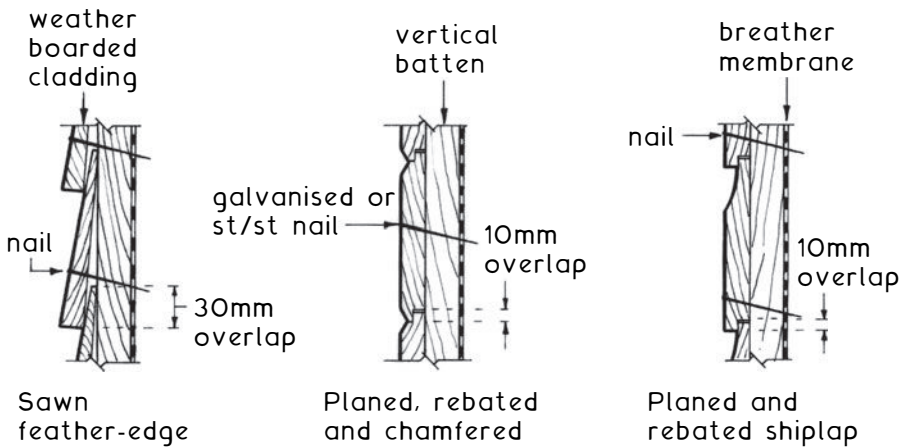

Ref. BS 1186-3: Timber for and workmanship in joinery. Specification for wood trim and its fixing.



## Tile Cladding – External Corners

External corner tiles are made to order as special fittings to standard plain tiles. In effect they are tile and a halves turned through 90° (other angles can be made) and handed left or right, fixed alternately to suit the overlapping pattern.

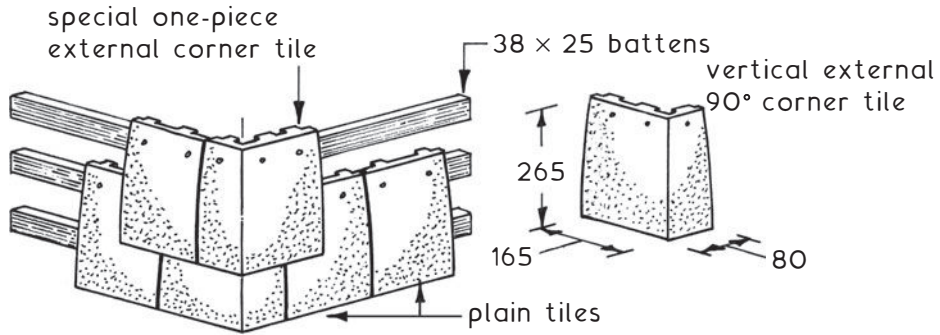

An alternative is to accurately mitre cut the meeting sides of tiles. This requires pairs of tile and a halves in alternate courses to maintain the bond. Lead soakers (1.75 mm) of at least 225 x 200 mm are applied to every course to weather the mitred cut edges. The top of each soaker is turned over the tiles and the bottom finished flush or slightly above the lower edge of tiles.

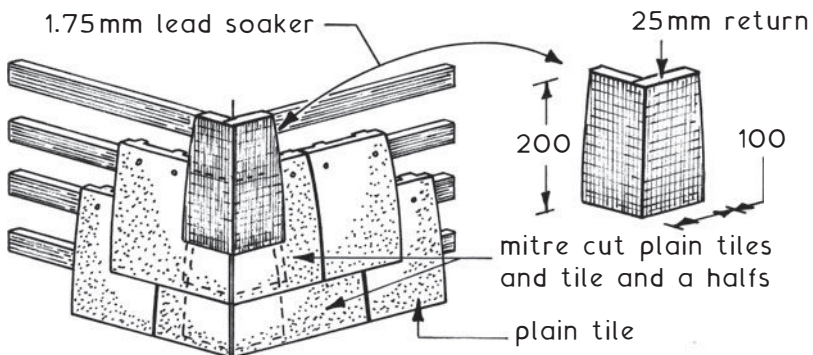

## Tile Cladding – Internal Corners

Internal corners are treated similarly to external corners by using special tiles of approximately tile and a half overall dimensions, turned through 90° (or other specified angle) in the opposing direction to external specials. These tiles are left and right handed and fixed alternately to vertical courses to maintain the overlapping bond.

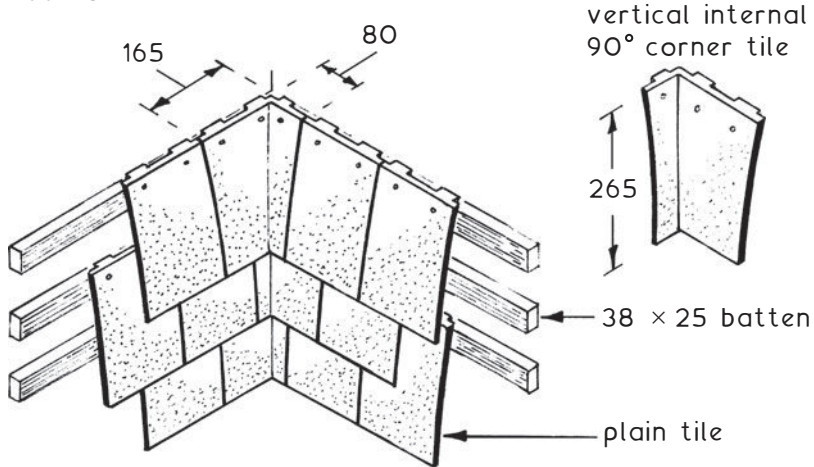

Internal angles can also be formed with mitre cut tiles, with tile and a half tiles in alternate courses. Lead soakers (1.75 mm) of 175 x 175 mm minimum dimensions are placed under each pair of corner tiles to weather the cut edges. As with external soakers, the lead is discretely hidden by accurate mitre cutting and shaping of tiles.

1.75mm lead soakers under every course of corner tiles

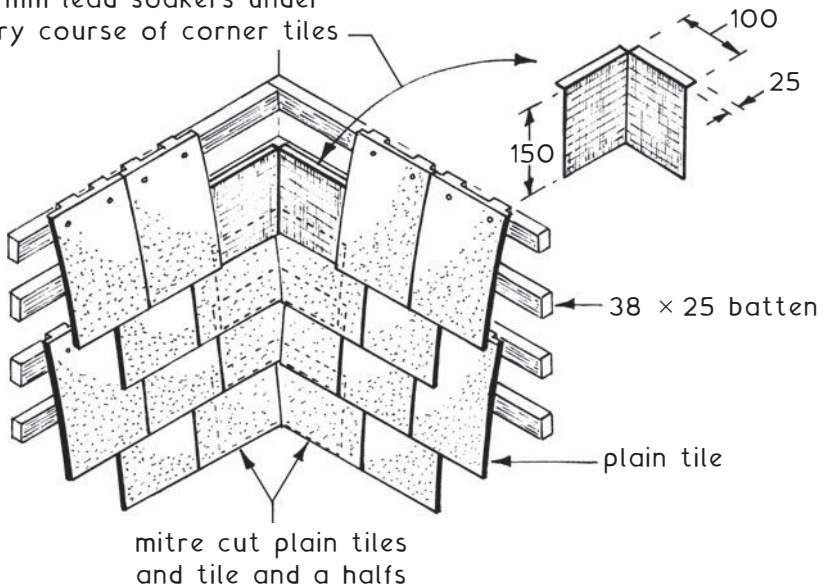

# Decorative Tile Cladding to External Walls

Some standard patterned bottom edge tiles ~

165 mm

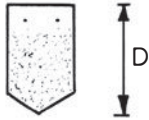

Arrowhead

165 mm

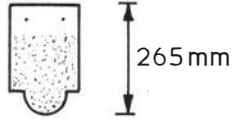

Club

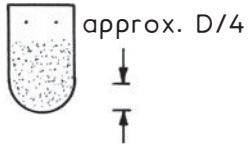

Bullnose,  
beavertail or spade

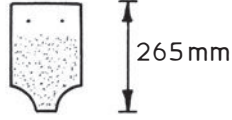

Scalloped  
or fishtail

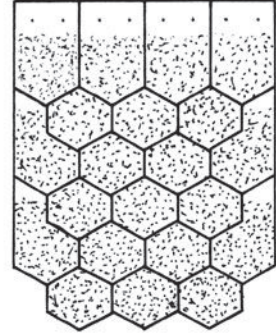

Arrowhead

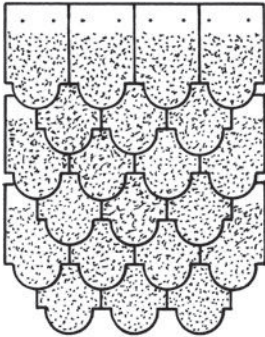

Club

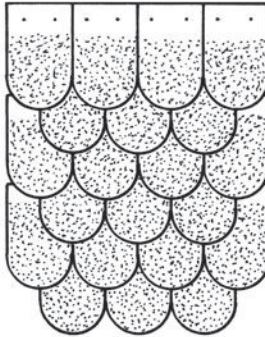

Bullnose

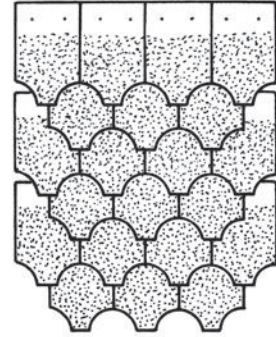

Scalloped

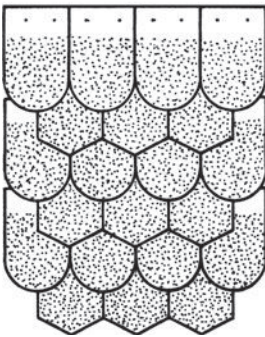

Bullnose and  
arrowhead

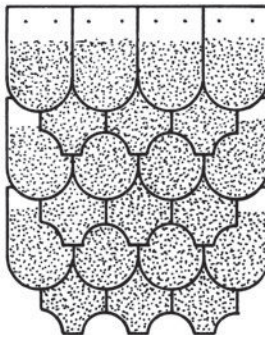

Bullnose and  
scalloped

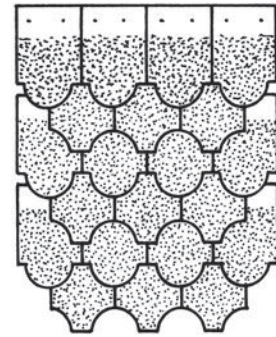

Club and  
scalloped

NB. May also be used as a roof-tiling feature, generally in two to three courses at 1.5 to 2.0 m intervals to relieve plain tiling.

Ordinary splay cutting to roof verge ~

Tile and a half tiles at the end of each course, cut to the undercloak course of roof tiling. A second nail hole can be drilled at the head of each cut tile for secure fixing to the parallel batten.

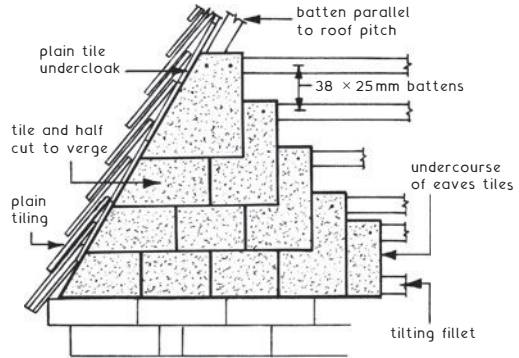

Winchester cutting to roof verge ~

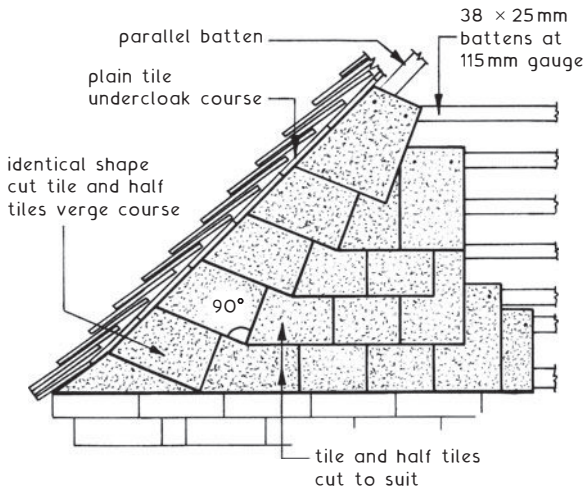

More attractive than ordinary splay cutting. Two cut tiles are required at the end of each course, varying in size depending on the roof pitch. Tile and half tiles should be used for these to avoid narrow cuts.

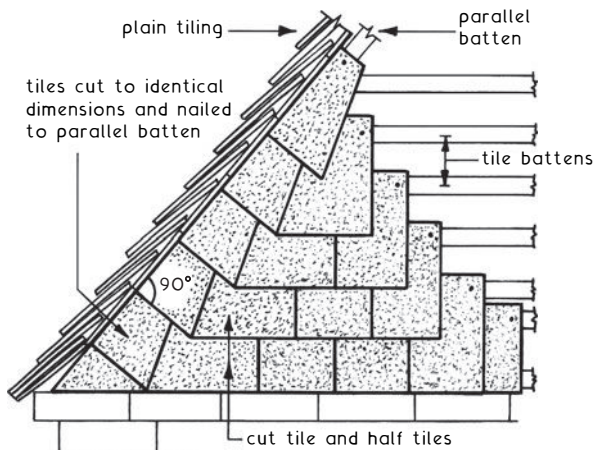

A variation that also has two cut tiles at the end of each course, has the square (90°) edge of the first course of tiles next to the roof tiling undercloak course.

## Mathematical Tile Cladding

Appearance and concept ~ a type of fake brickwork made up of clay tiles side and head lapped over each other to create the impression of brickwork, but without the expense. Joints/pointing can be in lime mortar or left dry.

History ~ originated during the eighteenth century, when they were used quite frequently on timber framed buildings notably in Kent and Sussex. Possibly this was to update and improve deteriorated weatherboarding or to avoid the brick tax of 1784. This tax was repealed in 1835.

Application ~ restoration to mathematically tiled older structures and as a lightweight cladding to modern timber-framed construction where the appearance of a brickwork façade is required.

Application shown in a Flemish bond ~

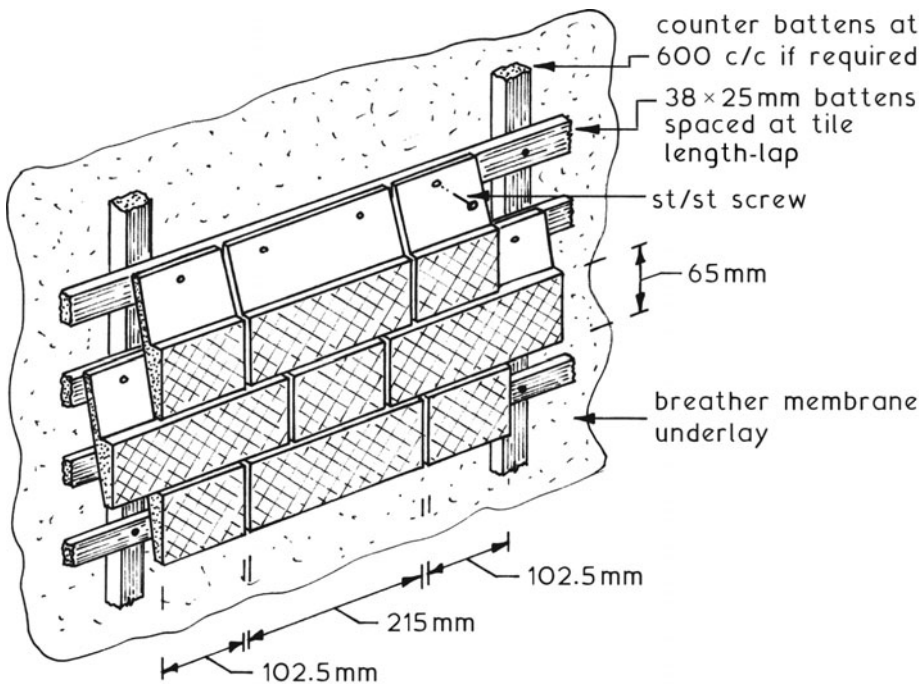

Brick slips ~ thin bricks resembling tiles of 15 to 20mm thickness with face dimensions the same as standard bricks (see page 395) and a finish or texture to match. Other terminology includes brick tiles, brick cladding units, slip bricks and briquettes.

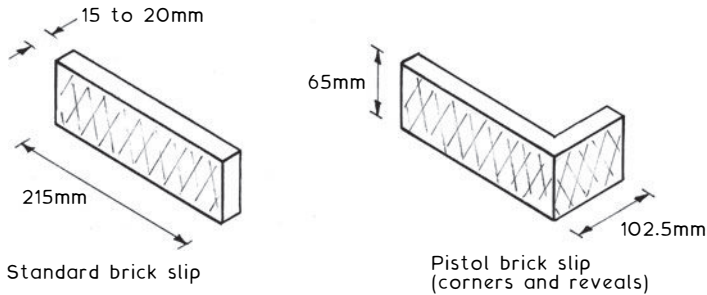

Application ~ used to maintain continuity of appearance where brickwork infill panels are supported by a reinforced concrete frame, as shown on page 699. Originally slips were cut from whole bricks, a time consuming and wasteful process no longer necessary, as most brick manufacturers make slips to complement their stock items. Other uses are as a cost effective dressing to inexpensive or repaired backgrounds and for use where it is too difficult to build with standard bricks.

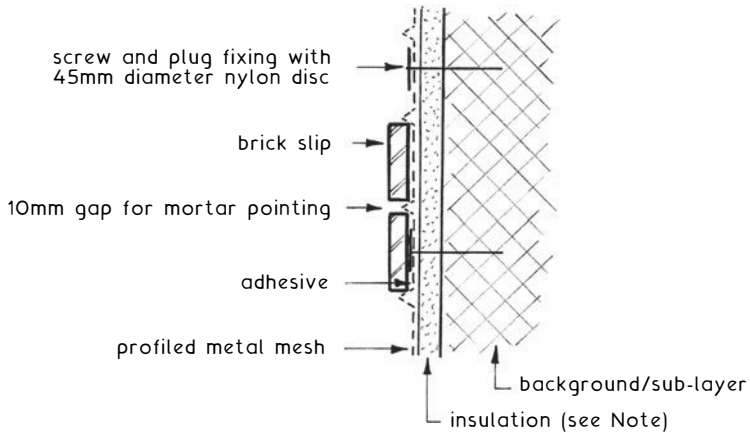

Support system ~ profiled galvanised or stainless steel mesh secured with screws and nylon discs 300mm horizontally and 150mm vertically apart into a sound background. Slips are stuck to the mesh with a structural adhesive of epoxy mortar, a two-part mix of resin and hardener combined with a sand filler.

Note: Extruded polystyrene closed cell foam insulating panel 25 to 50mm in thickness, adhesive secured to the background.

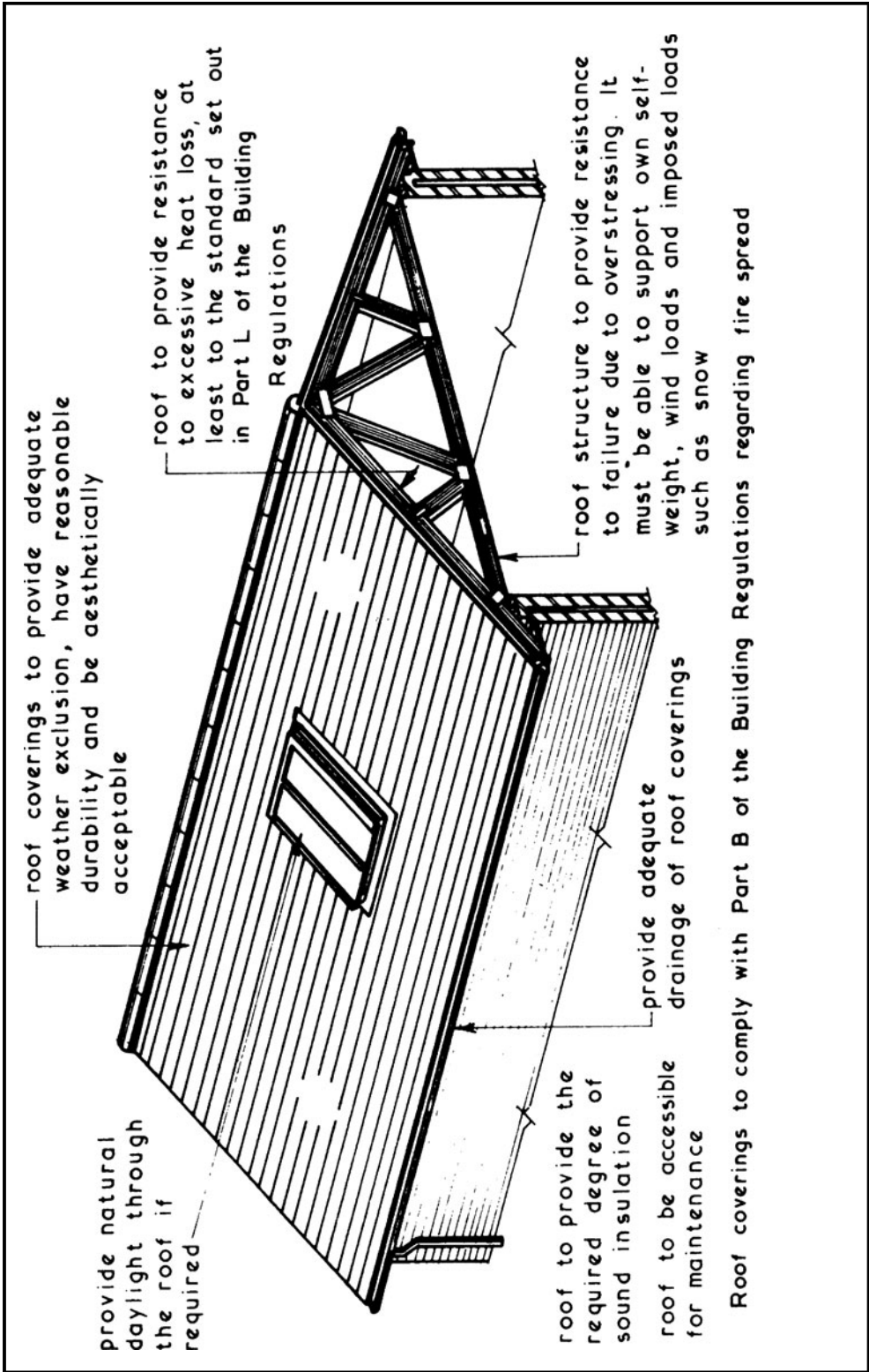

Roofs ~ these can be classified as either:

Flat - pitch from 0° to 10°

Pitched - pitch over 10°

It is worth noting that for design purposes roof pitches over 70° are classified as walls.

Roofs can be designed in many different forms and in combinations of these forms, some of which would not be suitable and/or economic for domestic properties.

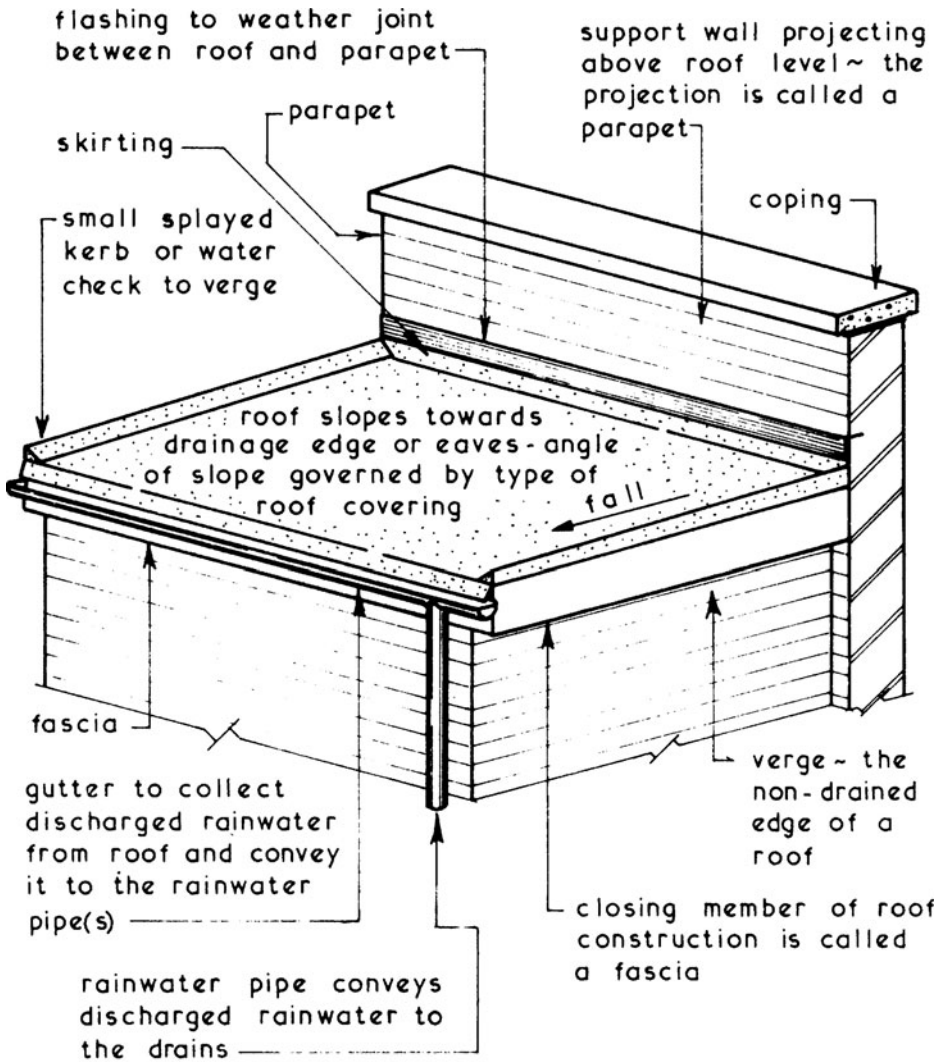

FLAT ROOFS



# Basic Roof Forms

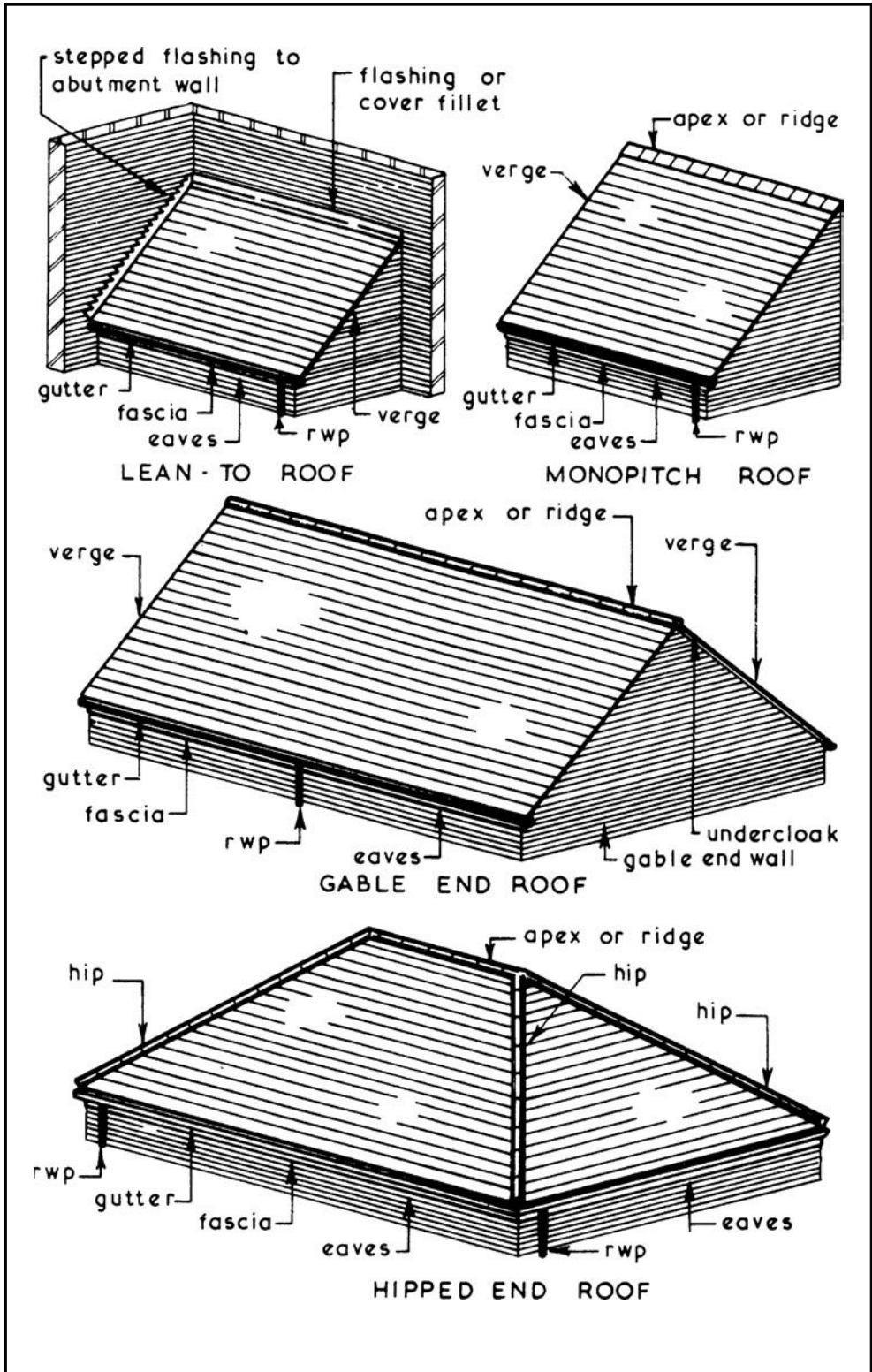

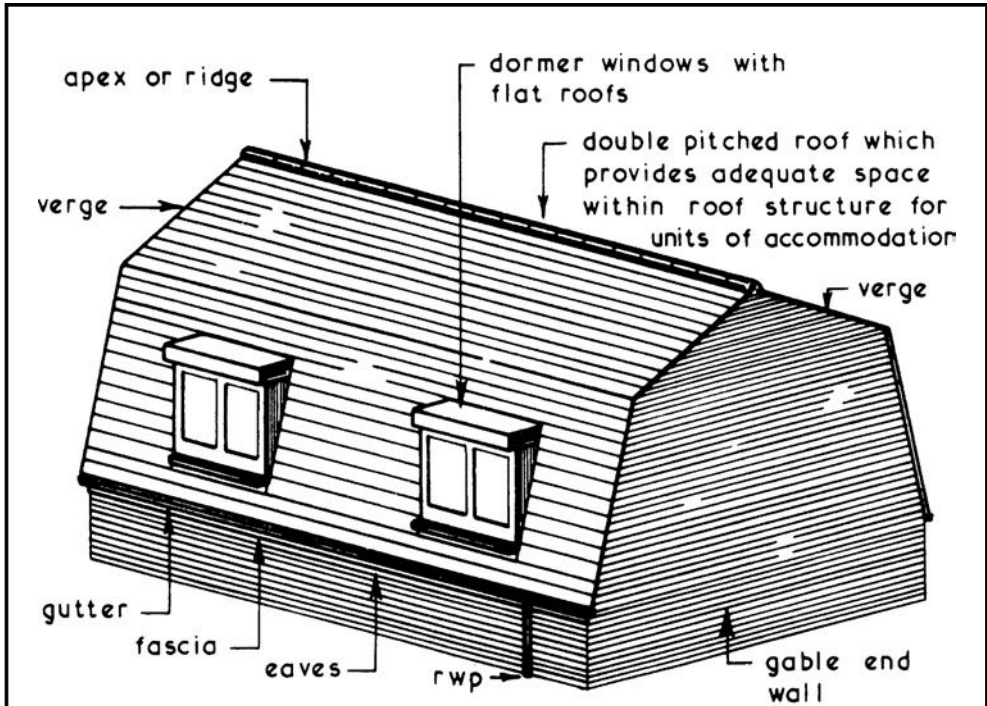

THE MANSARD OR GAMBREL ROOF

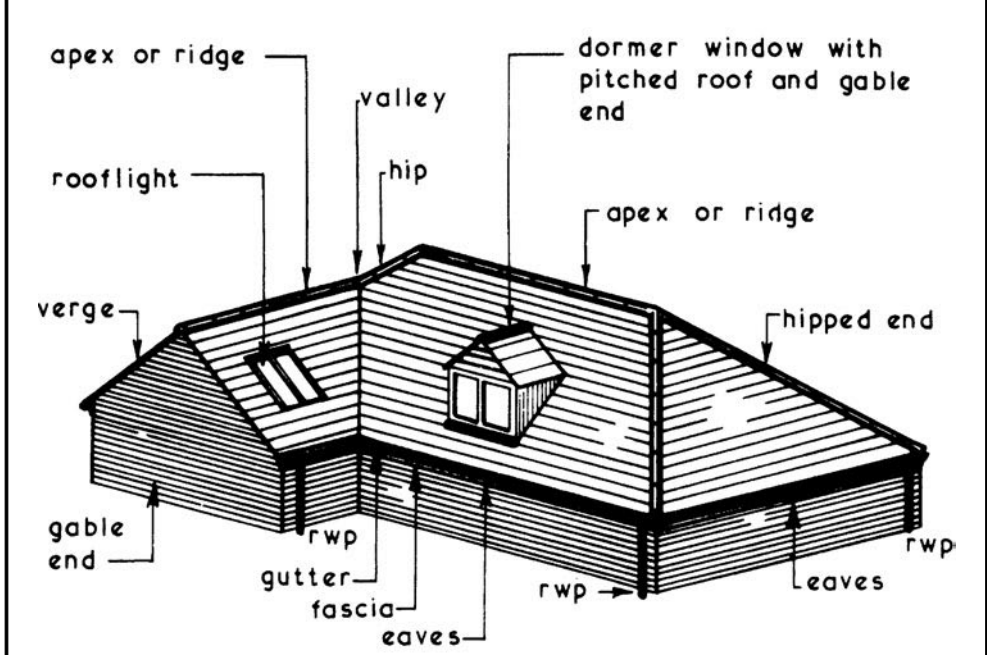

A COMBINATION OF BASIC FORMS

## Timber Pitched Roofs up to 7.5 m Span

Pitched Roofs ~ the primary functions of any domestic roof are to:

1. Provide an adequate barrier to the penetration of the elements.
2. Maintain the internal environment by providing an adequate resistance to heat loss.

A roof is in a very exposed situation and must therefore be designed and constructed in such a manner as to:

1. Safely resist all imposed loadings such as snow and wind.
2. Be capable of accommodating thermal and moisture movements.
3. Be durable so as to give a satisfactory performance and reduce maintenance to a minimum.

### Component Parts of a Pitched Roof ~

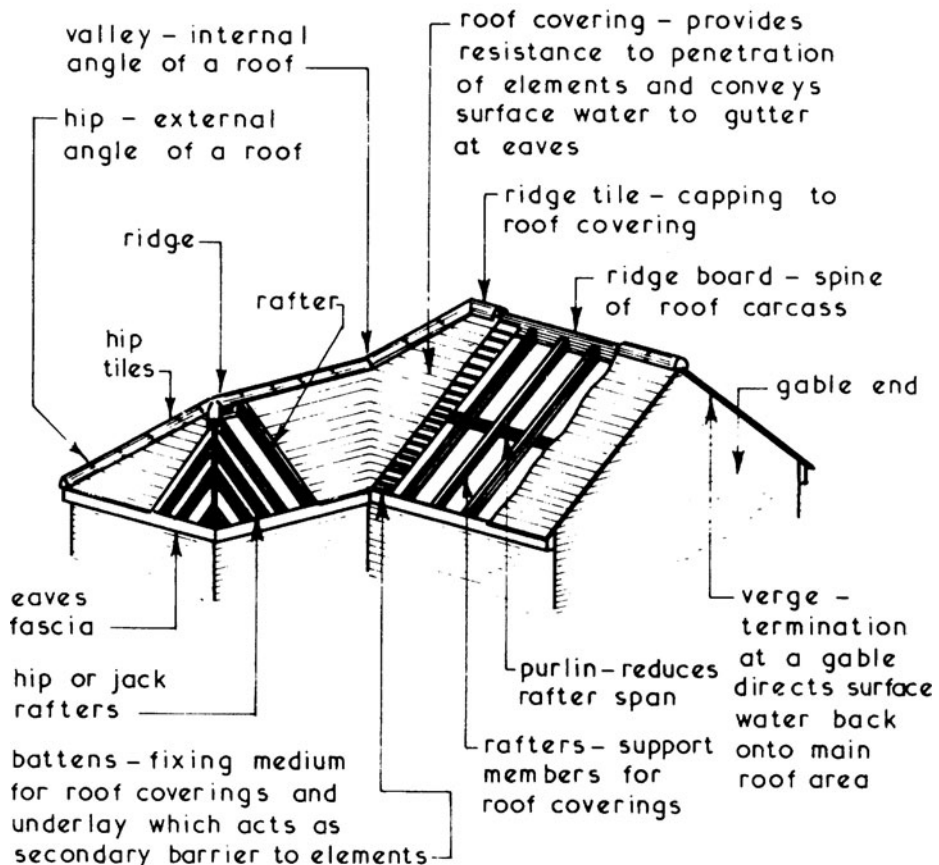

# Timber Pitched Roofs up to 7.5 m Span - Plan

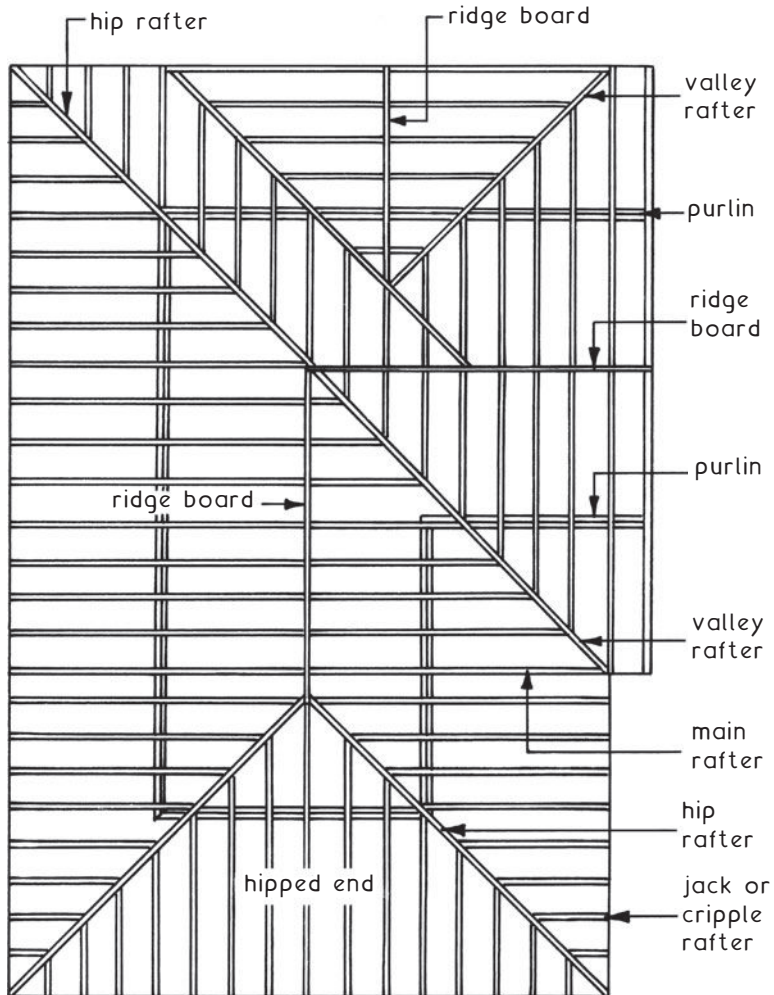

Purlins ~ guide to minimum size (mm) relative to span and spacing:

Span (m)	Spacing (m)		
	1.75	2.25	2.75
2.0	125 × 75	150 × 75	150 × 100
2.5	150 × 75	175 × 75	175 × 100
3.0	175 × 100	200 × 100	200 × 125
3.5	225 × 100	225 × 100	225 × 125
4.0	225 × 125	250 × 125	250 × 125

# Timber Pitched Roofs up to 7.5 m Span - Types

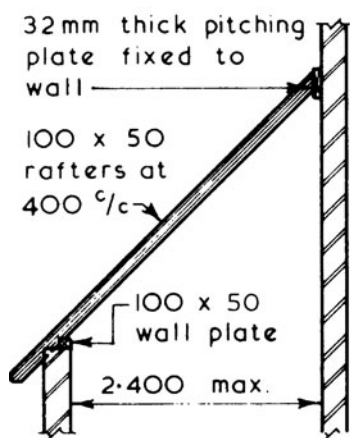

LEAN-TO ROOF

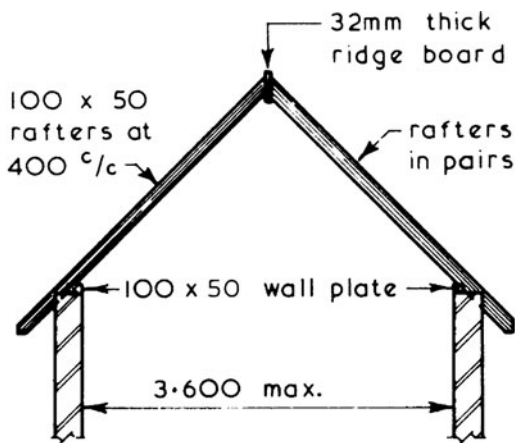

COUPLE ROOF

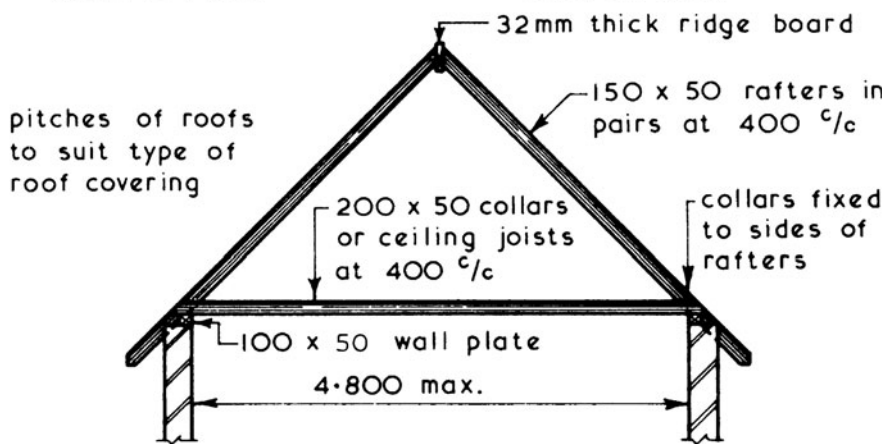

CLOSED COUPLE ROOF

minimum sizes for members of domestic type roofs can be obtained from 'Span Tables for Solid Timber Members' published by TRADA Technology Ltd.

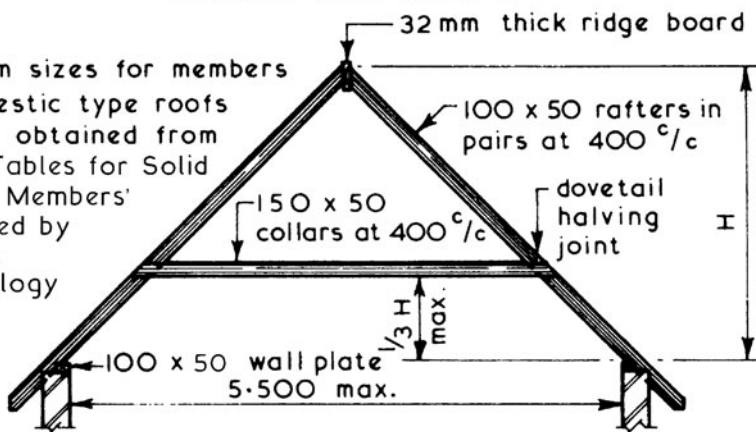

COLLAR ROOF

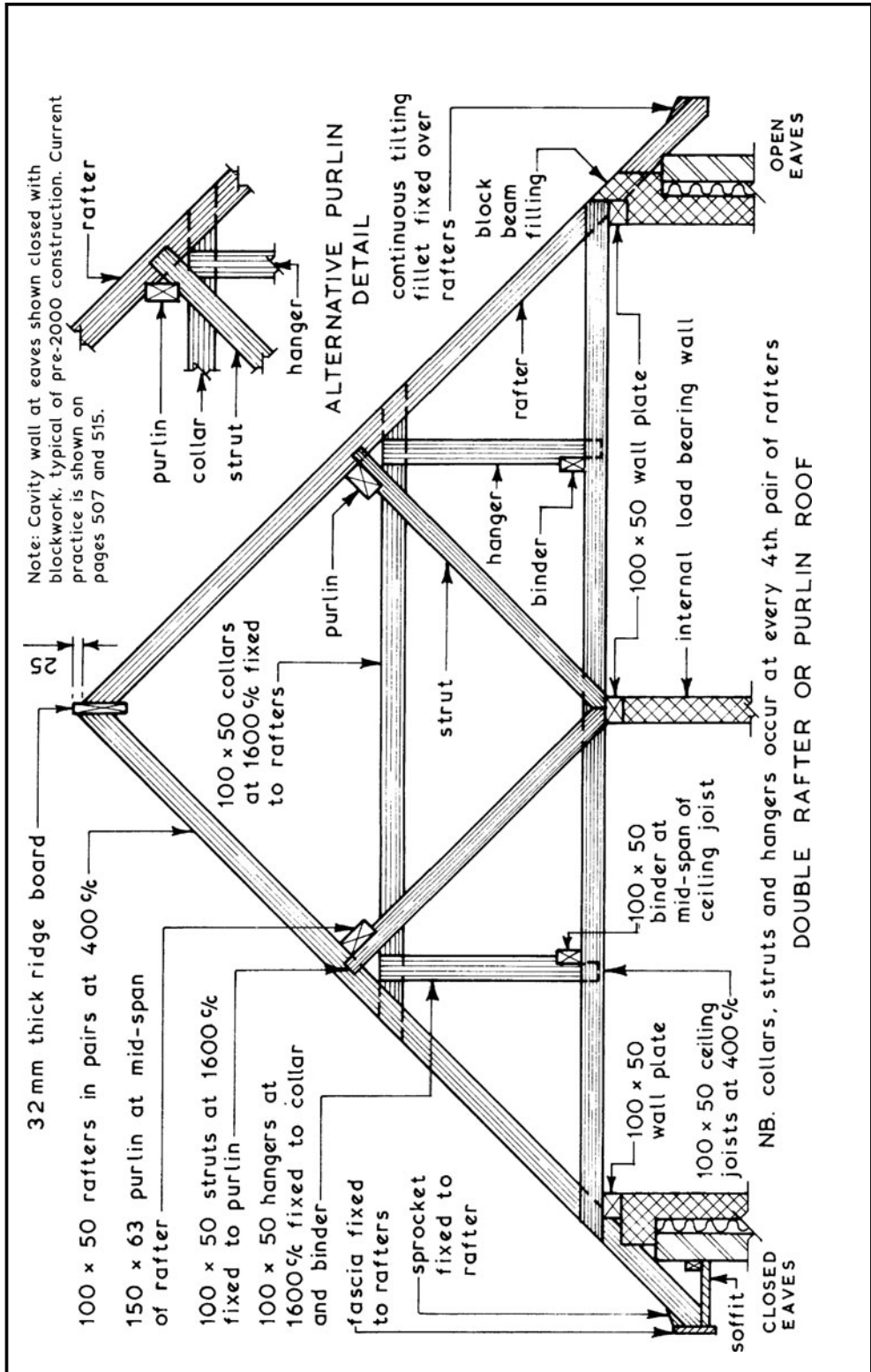

Roof Trusses ~ these are triangulated plane roof frames designed to give clear spans between the external supporting walls. They are usually prefabricated or partially prefabricated off site and are fixed at 1800 centres to support purlins which accept loads from the infill rafters.

See 'Note' previous page.

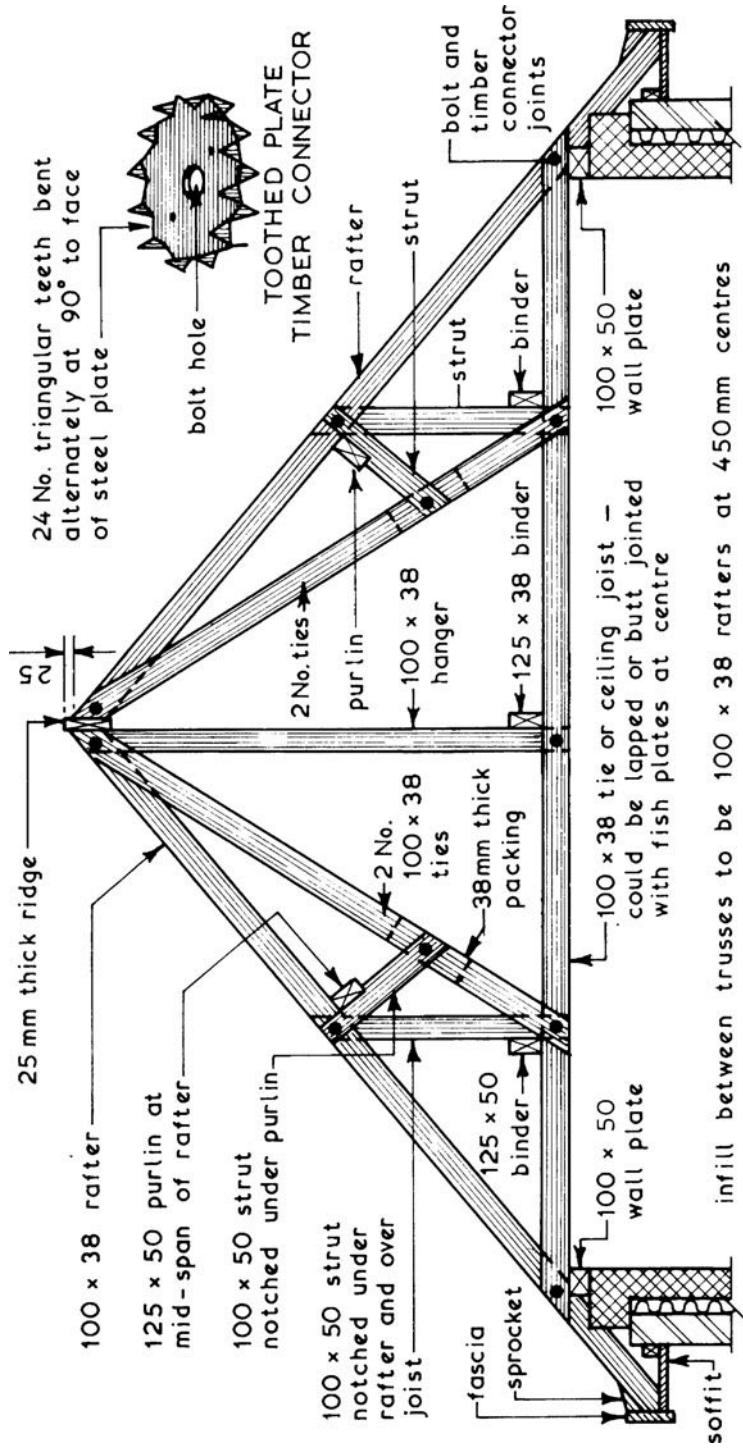

infill between trusses to be 100 x 38 rafters at 450mm centres

TYPICAL ROOF TRUSS DETAIL

Trussed Rafters ~ these are triangulated plane roof frames designed to give clear spans between the external supporting walls. They are delivered to site as a prefabricated component where they are fixed to the wall plates at 600 mm centres. Trussed rafters do not require any ridge boards or purlins since they receive their lateral stability by using larger tiling battens (50 x 25 mm) than those used on traditional roofs. See 'Note' on page 497.

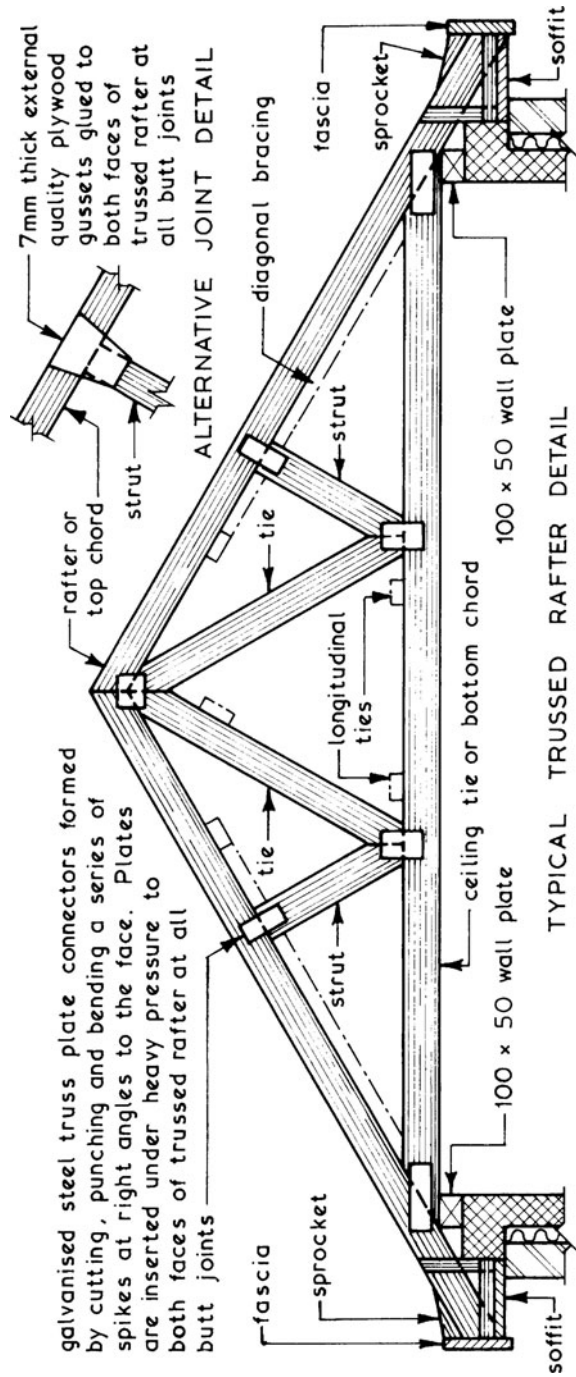

Longitudinal ties (75 x 38) fixed over ceiling ties and under internal ties near to roof apex and rafter diagonal bracing (75 x 38) fixed under rafters at gable ends from eaves to apex may be required to provide stability bracing - actual requirements specified by manufacturer. Lateral restraint to gable walls at top and bottom chord levels in the form of mild steel straps at 2.000 maximum centres over 2 No. trussed rafters may also be required.



# Trussed Purlin Roof

More economical for larger spans than with double rafters and ordinary purlins. Used where the size of purlins would be uneconomically large and/or an excessive number of struts, ties and hangers would be required

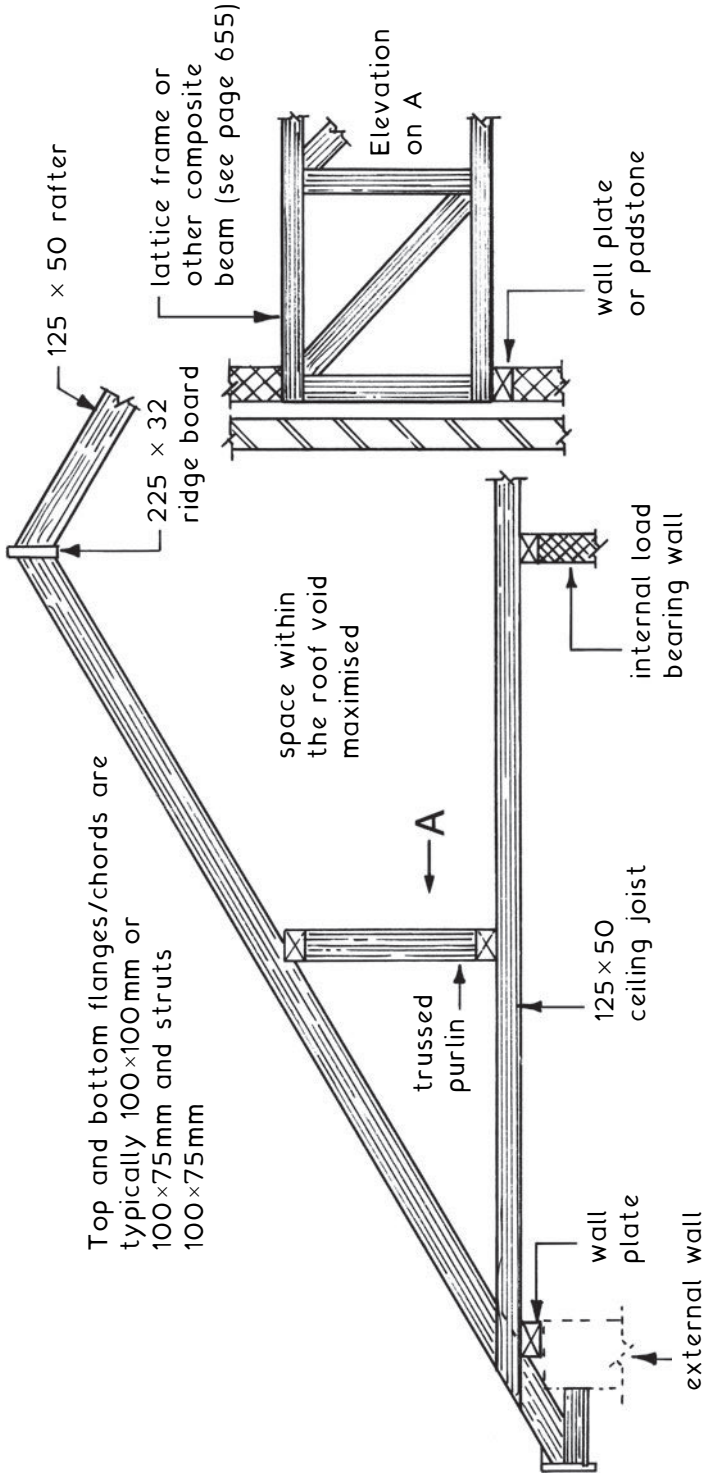

The lattice frame can be faced with plasterboard or with plywood for additional strength.

Gambrel roofs are double pitched with a break in the roof slope. The pitch angle above the break is less than  $45^\circ$  relative to the horizontal, whilst the pitch angle below the break is greater. Generally, these angles are  $30^\circ$  and  $60^\circ$ .

Gambrels are useful in providing more attic headroom and frequently incorporate dormers and rooflights. They have a variety of constructional forms.

Typically –

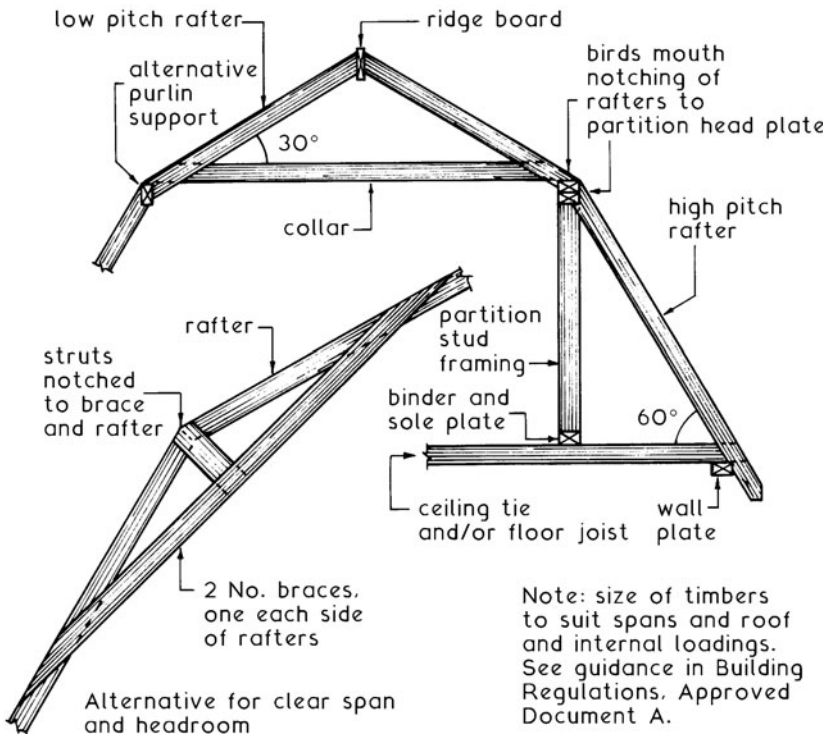

Intermediate support can be provided in various ways as shown above. To create headroom for accommodation in what would otherwise be attic space, a double head plate and partition studding is usual. The collar beam and rafters can conveniently locate on the head plates or prefabricated trusses can span between partitions.

## Valley Construction

Valley construction and associated pitched roofing is used:

- to visually enhance an otherwise plain roof structure.
- where the roof plan turns through an angle (usually 90°) to follow the building layout or a later extension.
- at the intersection of main and projecting roofs above a bay window or a dormer window.

Construction may be by forming a framework of cut rafters trimmed to valley rafters as shown in the roof plan on page 495. Alternatively, and as favoured with building extensions, by locating a valley or lay board over the main rafters to provide a fixing for each of the jack rafters.

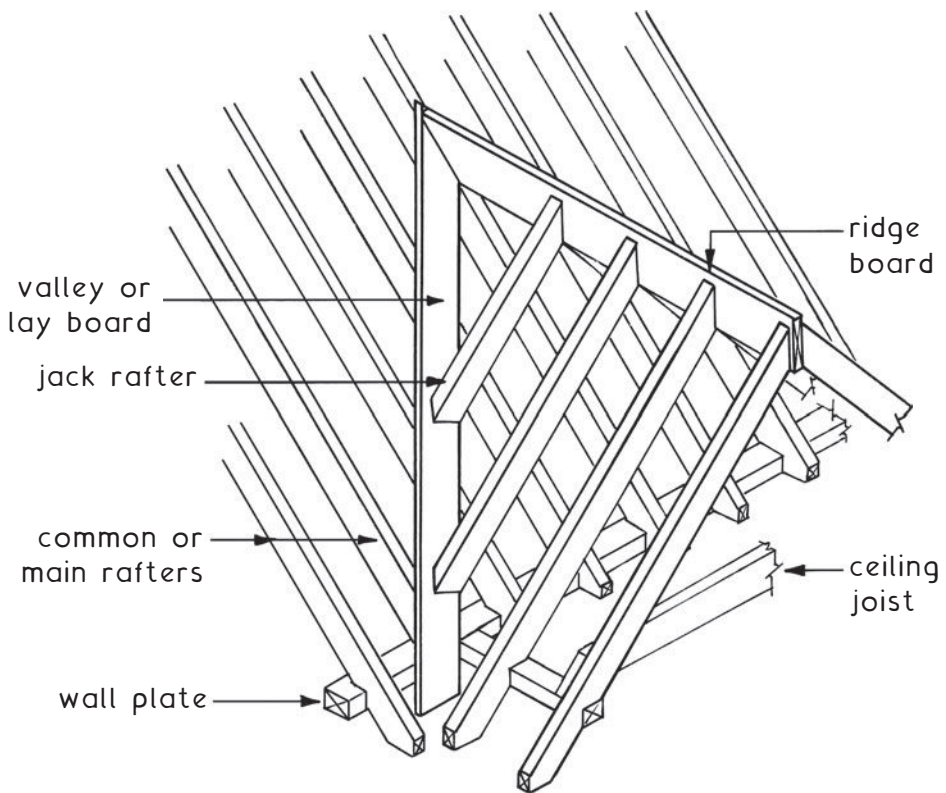

Sprockets may be provided at the eaves to reduce the slope of a pitched roof. Sprockets are generally most suitable for use on wide, steeply pitched roofs to:

- enhance the roof profile by creating a feature.
- to slow down the velocity of rainwater running off the roof and prevent it from overshooting the gutter.

Where the rafters overhang the external wall, taper cut timber sprockets can be attached to the top of the rafters. Alternatively, the ends of rafters can be birds mouthed onto the wall plate and short lengths of timber the same size as the rafters secured to the rafter feet. In reducing the pitch angle, albeit for only a short distance, it should not be less than the minimum angle recommended for specific roof coverings.

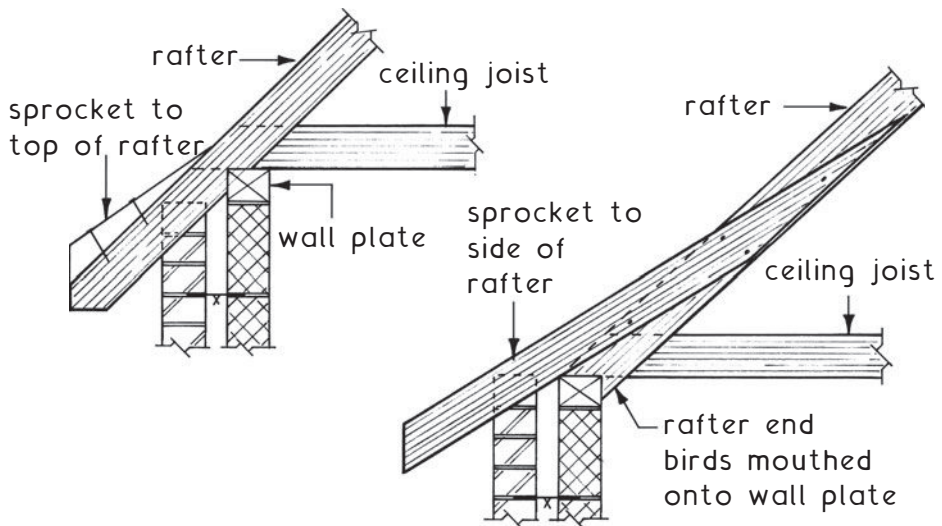

Types of sprocketed eaves

## Roof Underlays

Roof Underlays ~ sometimes called sarking or roofing felt provides the barrier to the entry of snow, wind and rain blown between the tiles or slates. It also prevents the entry of water from capillary action.

Suitable Materials ~

Bitumen fibre-based felts - supplied in rolls 1m wide and up to 25 m long. Traditionally used in house construction with a cold ventilated roof.

Breather or vapour permeable underlay - typically produced from HDPE fibre or extruded polypropylene fibre, bonded by heat and pressure. Materials permeable to water vapour are preferred as these do not need to be perforated to ventilate the roof space. Also, subject to manufacturer's guidelines, traditional eaves ventilation may not be necessary. Underlay of this type should be installed taut across the rafters with counter battens support to the tile battens. Where counter battens are not used, underlay should sag slightly between rafters to allow rain penetration to flow under tile battens.

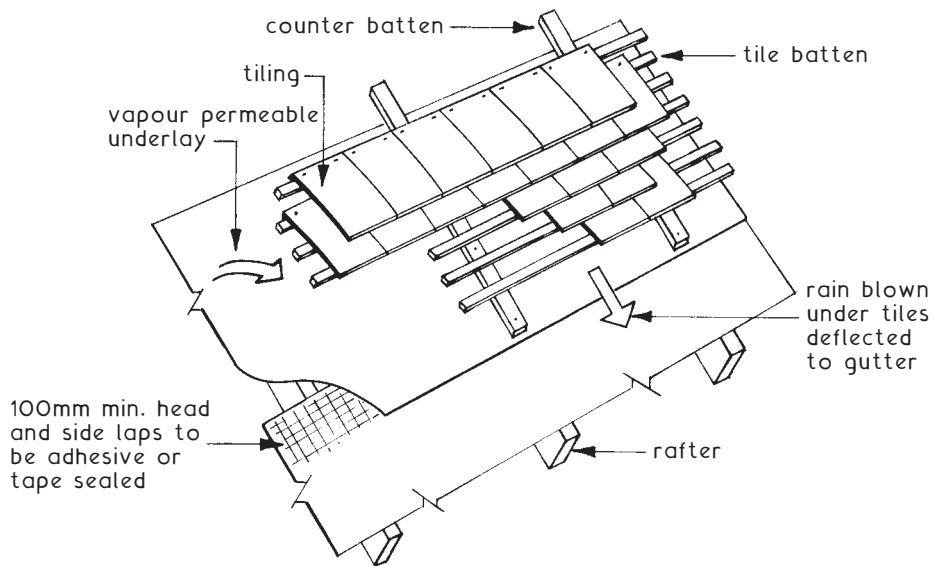

Underlays are fixed initially with galvanised clout nails or st/st staples but are finally secured with the tiling or slating batten fixings

Double Lap Tiles ~ these are the traditional tile covering for pitched roofs and are available made from clay and concrete and are usually called plain tiles. Plain tiles have a slight camber in their length to ensure that the tail of the tile will bed and not ride on the tile below. There are always at least two layers of tiles covering any part of the roof. Each tile has at least two nibs on the underside of its head so that it can be hung on support battens nailed over the rafters. Two nail holes provide the means of fixing the tile to the batten; in practice only every fourth course of tiles is nailed unless the roof exposure is high. Double lap tiles are laid to a bond so that the edge joints between the tiles are in the centre of the tiles immediately below and above the course under consideration.

Minimum pitch 35° machine-made, 45° hand-made.

Typical Plain Tile Details ~

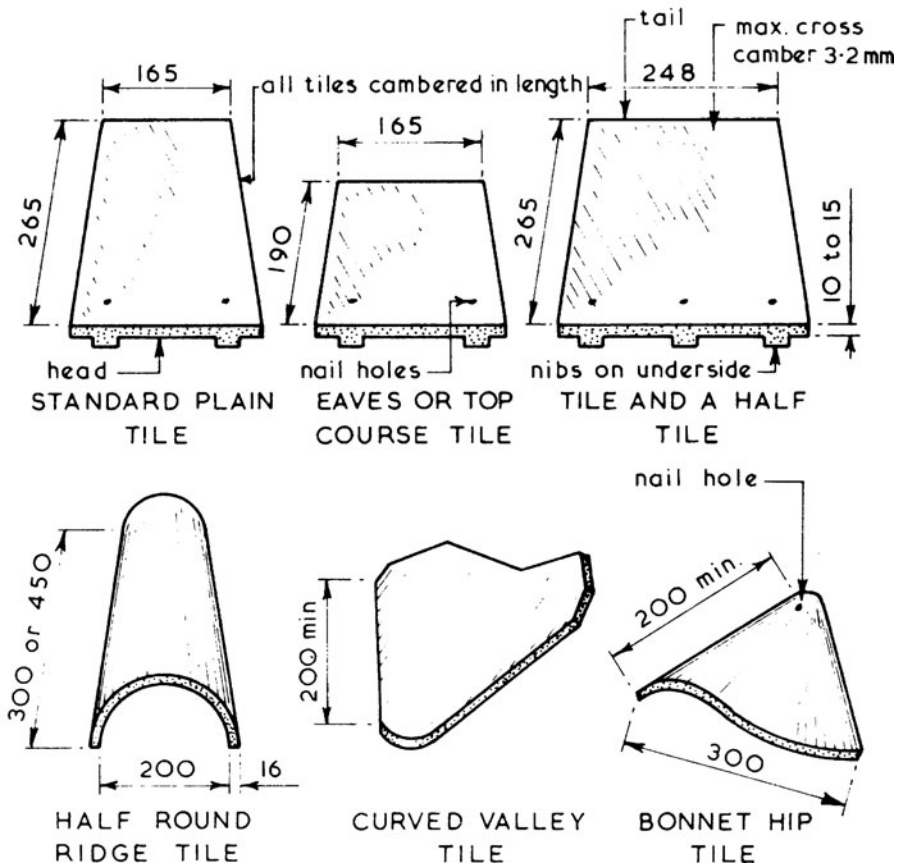

For other types, shapes and sections see BS EN 1304: Clay roofing tiles and fittings. Product definitions and specifications.

## Double Lap Peg Tiles

Hand-made from extracted clay substrata. Sources of suitable clay in the UK are the brick making areas of Kent, Sussex and Leicestershire.

Tiles are shaped in a timber frame or clamp before being kiln fired at about 1000°C. Early examples of these tiles have been attributed to the Romans, but after they left the UK manufacture all but ceased until about the twelfth century. Historically and today, tile dimensions vary quite significantly, especially those from different regions and makers. In 1477 a Royal Charter attempted to standardise tiles to  $10\frac{1}{2}'' \times 6\frac{1}{2}'' \times \frac{1}{2}''$  thick (265 × 165 × 12 mm) and this remains as the BS dimensions shown on the previous page. However, peg tile makers were set in their ways and retained their established local dimensions. This means that replacements have to be specifically produced to match existing tiles.

Peg tile showing  
general range of  
dimensions

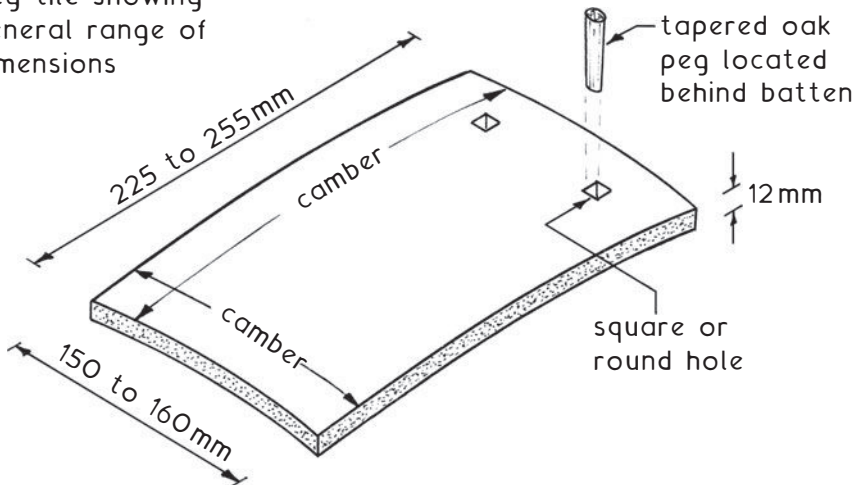

Typical regional sizes ~

Sussex	$9\frac{1}{2}'' \times 6\frac{1}{4}''$	(240 × 160 mm)
Kent	$10'' \times 6''$	(255 × 150 mm)
Leicestershire	$11'' \times 7''$	(280 × 180 mm)

Typical details (cold roof) ~

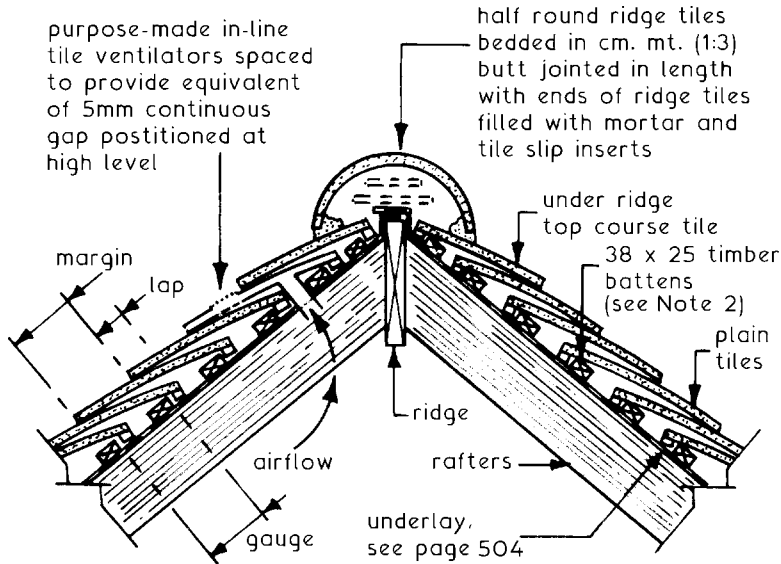

RIDGE DETAIL

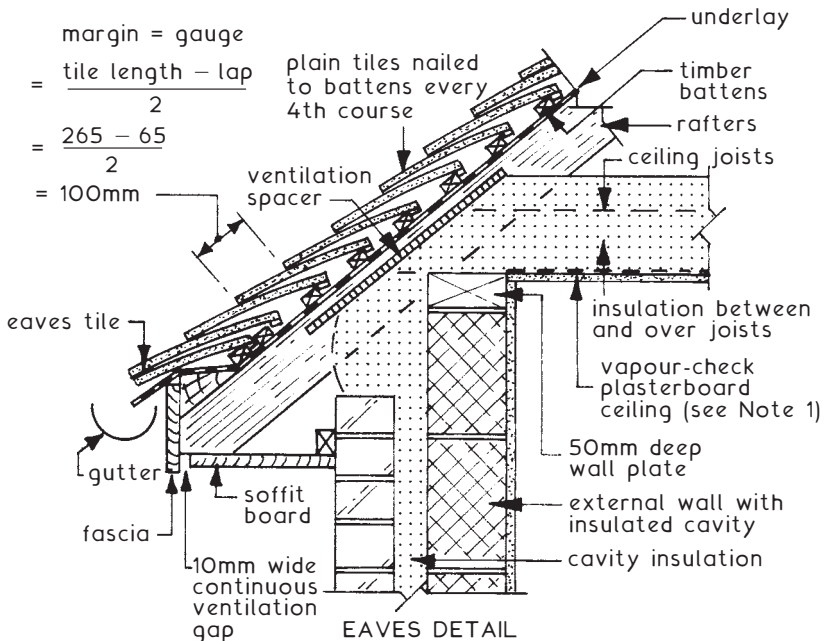

EAVES DETAIL

Note 1: Through ventilation is necessary to prevent condensation from occurring in the roof space. A vapour check can also help limit the amount of moisture entering the roof void.

Note 2: 50 x 25 where rafter spacing is 600mm.



## Eaves and Ridge – Alternative Treatment

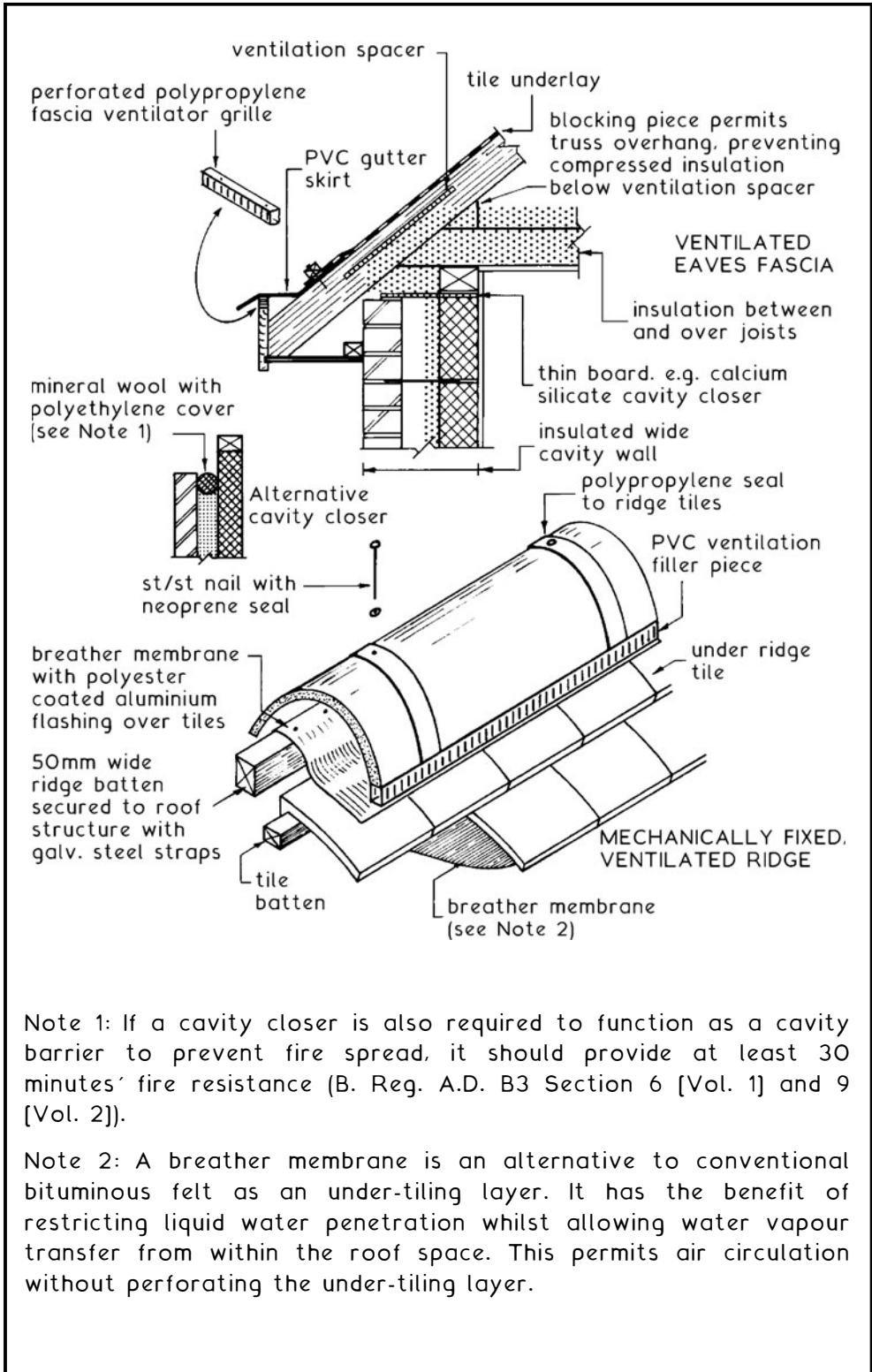

Note 1: If a cavity closer is also required to function as a cavity barrier to prevent fire spread, it should provide at least 30 minutes' fire resistance (B. Reg. A.D. B3 Section 6 [Vol. 1] and 9 [Vol. 2]).

Note 2: A breather membrane is an alternative to conventional bituminous felt as an under-tiling layer. It has the benefit of restricting liquid water penetration whilst allowing water vapour transfer from within the roof space. This permits air circulation without perforating the under-tiling layer.

Typical detail (warm roof) ~

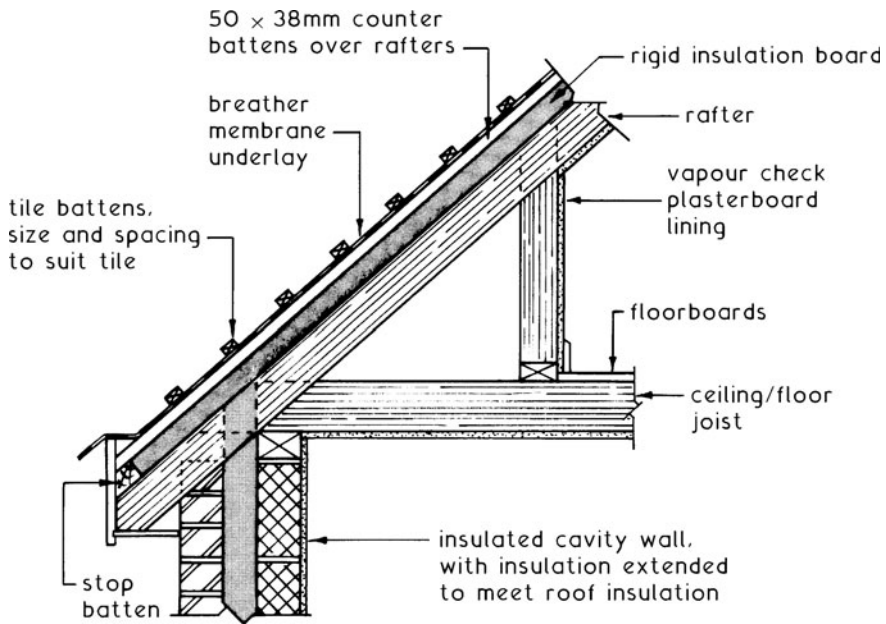

Where a roof space is used for habitable space, insulation must be provided within the roof slope. Insulation above the rafters (as shown) creates a 'warm roof', eliminating the need for continuous ventilation. Insulation placed between the rafters creates a 'cold roof', where a continuous 50mm ventilation void above the insulation will assist in the control of condensation (see next page).

Suitable rigid insulants include: low density polyisocyanurate (PIR) foam, reinforced with long strand glass fibres, both faces bonded to aluminium foil with joints aluminium foil taped on the upper surface; high density mineral wool slabs over rafters with less dense mineral wool between rafters.

An alternative location for the breather membrane is under the counter battens. This is often preferred as the insulation board will provide uniform support for the underlay. Otherwise, extra insulation could be provided between the counter battens, retaining sufficient space for the underlay to sag between rafter positions to permit any rainwater penetration to drain to eaves.

## Pitched Roof – Insulation Between Rafters

Insulation in between rafters is an alternative to placing it above (see page 570). The following details show two possibilities, where if required supplementary insulation can be secured to the underside of rafters.

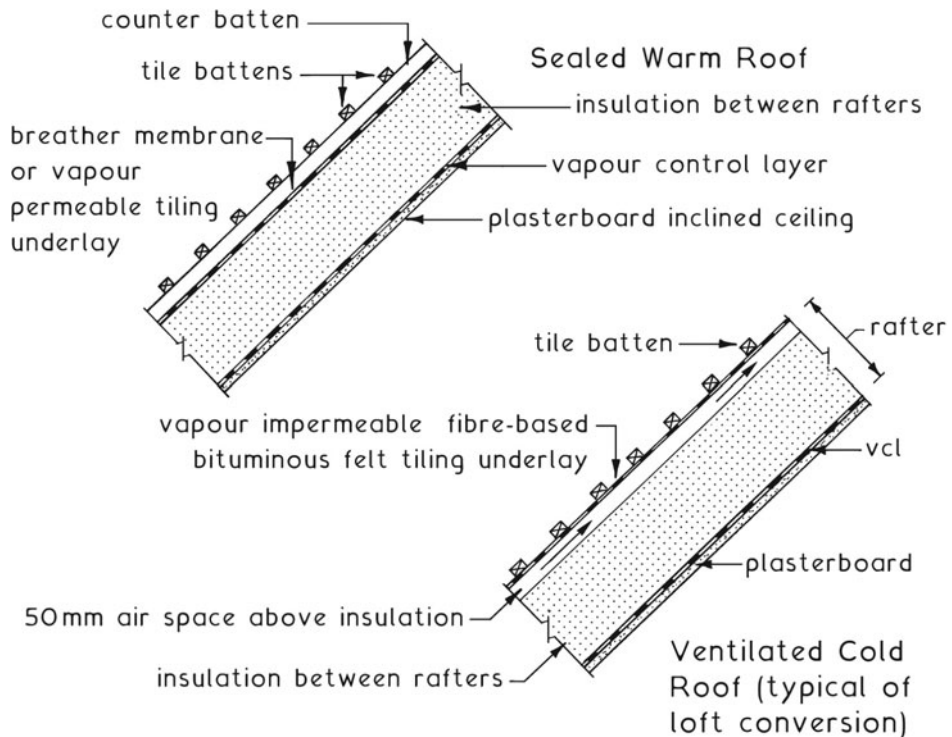

Vapour control layer ~ condensation occurs where warm moist air contacts a cold layer. This could be in the roof space above inhabited rooms, where permeable insulation will not prevent movement of moisture in air and vapour from condensing on the underside of traditional tile underlay (sarking felt) and bituminous felt flat roof coverings. Venting of the roof space (see pages 540 to 541) will control condensation.

Alternatively it can be controlled with a well sealed vapour control layer (for instance, foil [metallised polyester] backed plasterboard) incorporated in the ceiling lining and used with a vapour permeable (breather membrane) underlay to the tiling. Joints and openings in the vcl ceiling (e.g. cable or pipe penetrations) should be sealed, but if this is impractical ventilation should be provided to the underside of the tile underlay.

## Pitched Roof – Structural Insulated Panels (SIPs)

SIPs are prefabricated 'sandwich' panels that can be used as an alternative to traditional rafters or trusses for roof construction. They can also be used for structural wall panels. Surface layers of plywood or OSB are separated by a core of insulation. The outer face can be provided with counter battens for securing tile battens.

Properties ~

High strength to weight ratio.

Good thermal insulation.

Continuity of insulation, no cold bridges.

Good sound insulation.

Fire-retardant core with improved resistance to fire by lining the inner face with plasterboard.

Dimensionally coordinated.

Factory cut to specification, including mitres and angles for ridge, valleys, hips, etc.

Rapid and simple site assembly.

Panel size ~ typically 1.2m wide in lengths up to 8.0m.

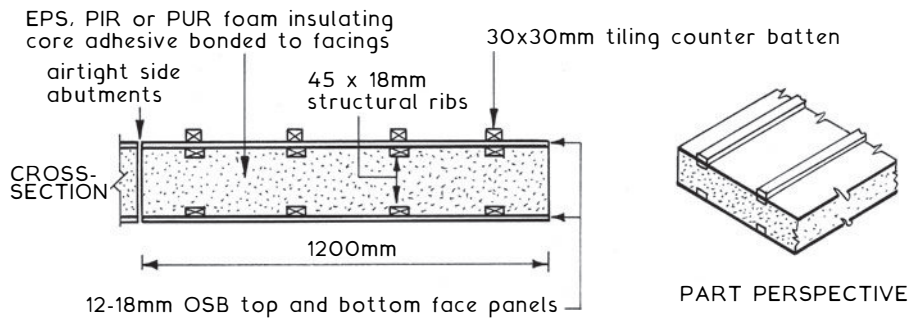

Typical thermal insulation values ~

Depth/thickness, exc. battens (mm)	U-value (W/m <sup>2</sup> K)
100	0.35
150	0.25
200	0.20
250	0.15

Key: EPS – Expanded polystyrene. PIR – Polyisocyanurate, rigid foam.

PUR – Rigid polyurethane. OSB – Oriented strand board.

Typical Details ~

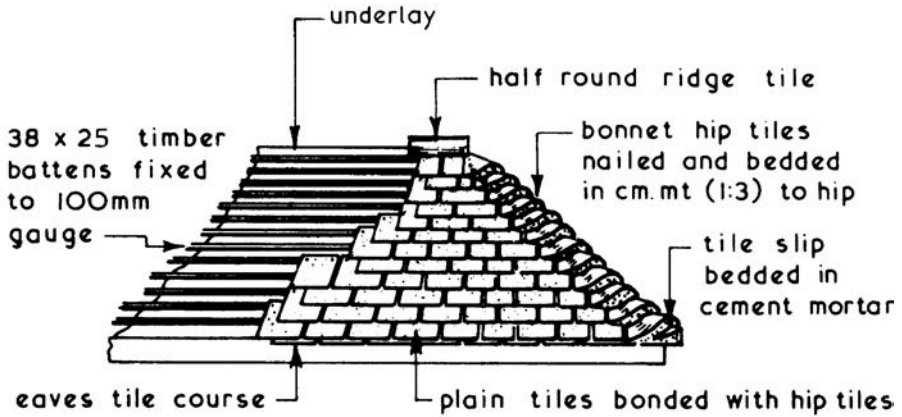

HIP DETAIL USING BONNET HIP TILES

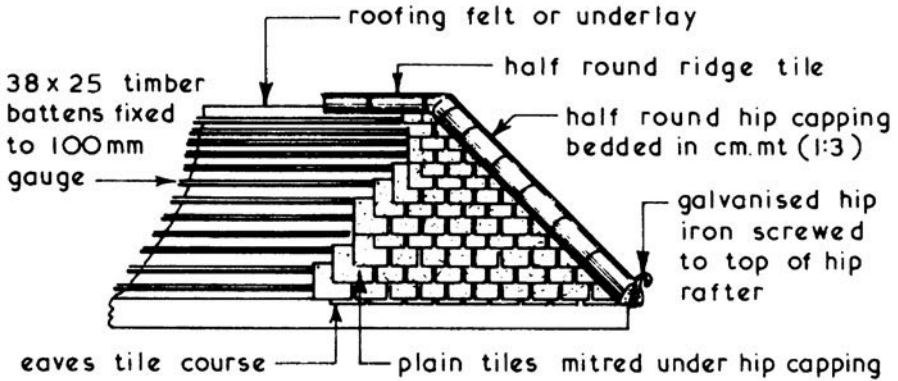

HIP DETAIL USING HALF ROUND TILES

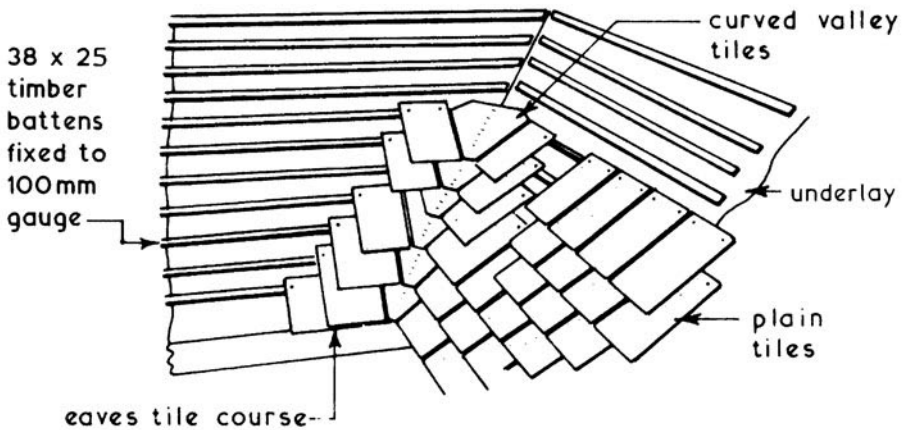

VALLEY DETAIL USING CURVED VALLEY TILES

Typical Details ~

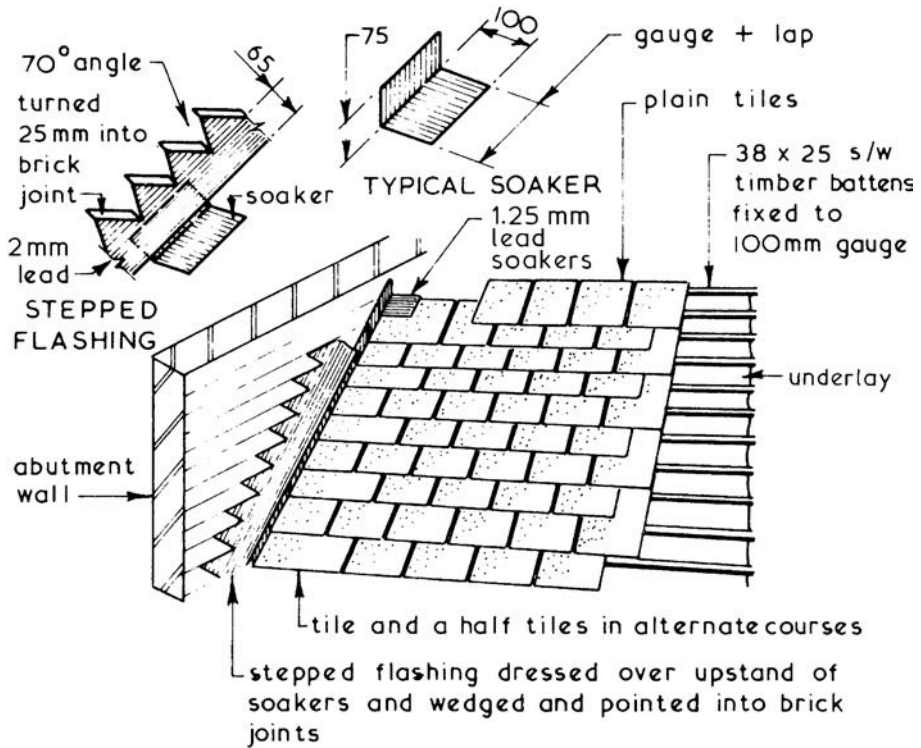

ABUTMENT DETAIL

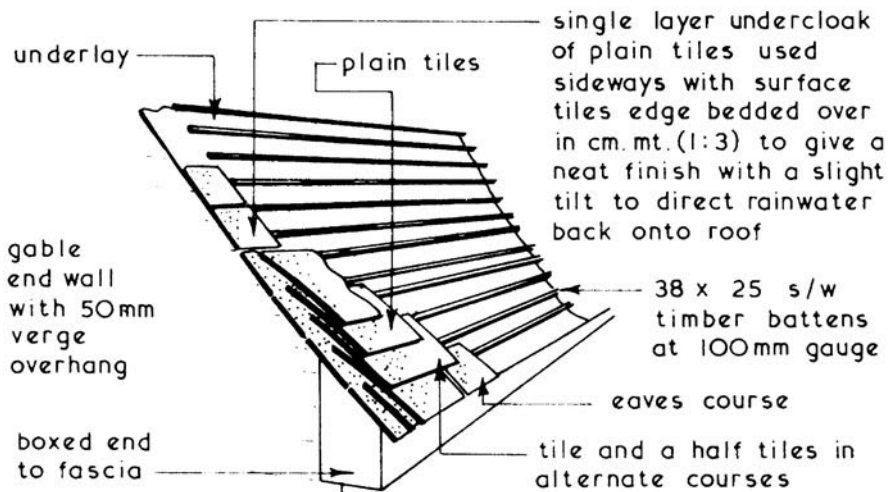

VERGE DETAIL

# Single Lap Tiling

Single Lap Tiling ~ so called because the single lap of one tile over another provides the weather tightness as opposed to the two layers of tiles used in double lap tiling. Most of the single lap tiles produced in clay and concrete have a tongue and groove joint along their side edges and in some patterns on all four edges which forms a series of interlocking joints and therefore these tiles are called single lap interlocking tiles. Generally there will be an overall reduction in the weight of the roof covering when compared with double lap tiling but the batten size is larger than that used for plain tiles and as a minimum every tile in alternate courses should be twice nailed, although a good specification will require every tile to be twice nailed. The gauge or batten spacing for single lap tiling is found by subtracting the end lap from the length of the tile.

Typical Single Lap Tiles ~

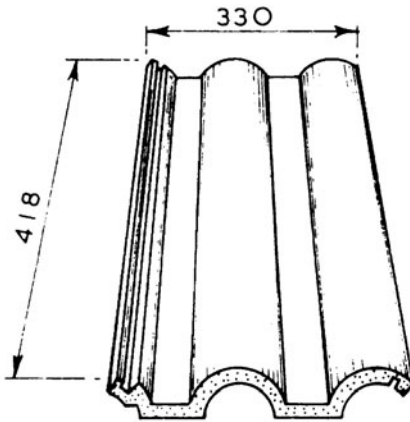

ROLL TYPE TILE  
minimum pitch  $30^{\circ}$   
head lap 75mm  
side lap 30mm  
gauge 343mm  
linear coverage 300mm

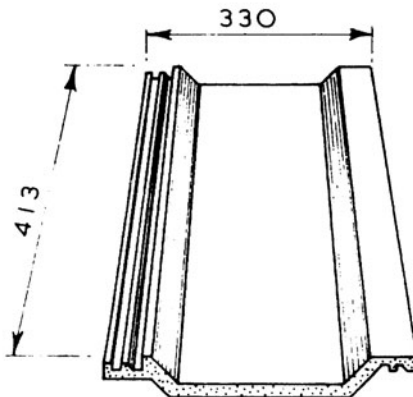

TROUGH TYPE TILE  
minimum pitch  $15^{\circ}$   
head lap 75mm  
side lap 38mm  
gauge 338mm  
linear coverage 292mm

Typical Details ~

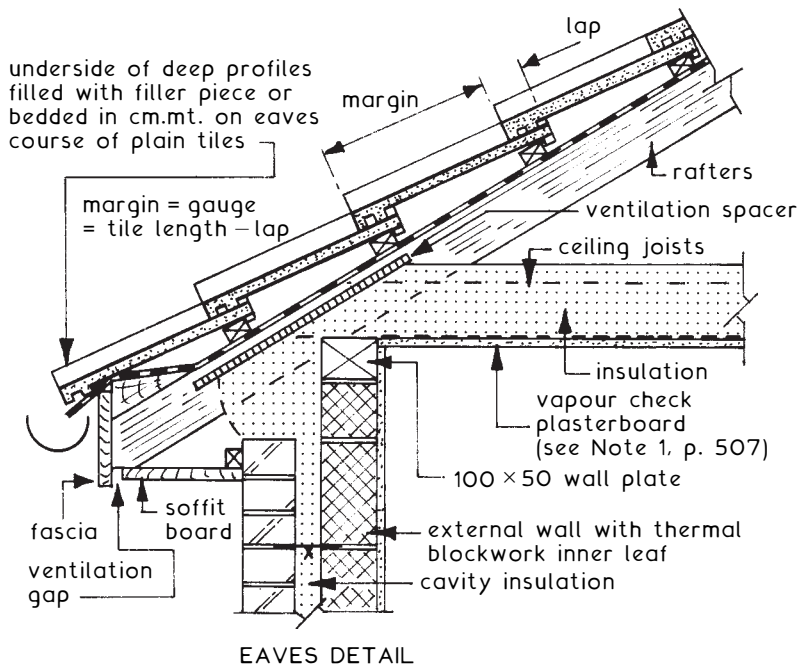
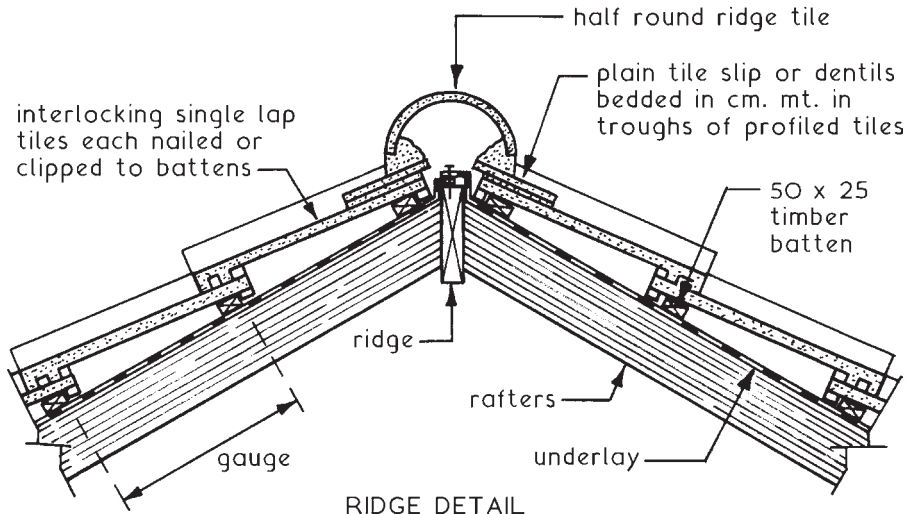

Hips - can be finished with a half round tile as a capping as shown for double lap tiling on page 512.

Valleys - these can be finished by using special valley trough tiles or with a lead lined gutter - see manufacturer's data.



## Roof Slating

Slates ~ slate is a natural dense material which can be split into thin sheets and cut to form a small unit covering suitable for pitched roofs in excess of 25° pitch. Slates are graded according to thickness and texture, the thinnest being known as 'Bests'. These are of 4 mm nominal thickness. Slates are laid to the same double lap principles as plain tiles. Ridges and hips are normally covered with half round or angular tiles whereas valley junctions are usually of mitred slates over soakers. Unlike plain tiles every course is fixed to the battens by head or centre nailing, the latter being used on long slates and on pitches below 35° to overcome the problem of vibration caused by the wind which can break head nailed long slates.

Typical Details ~

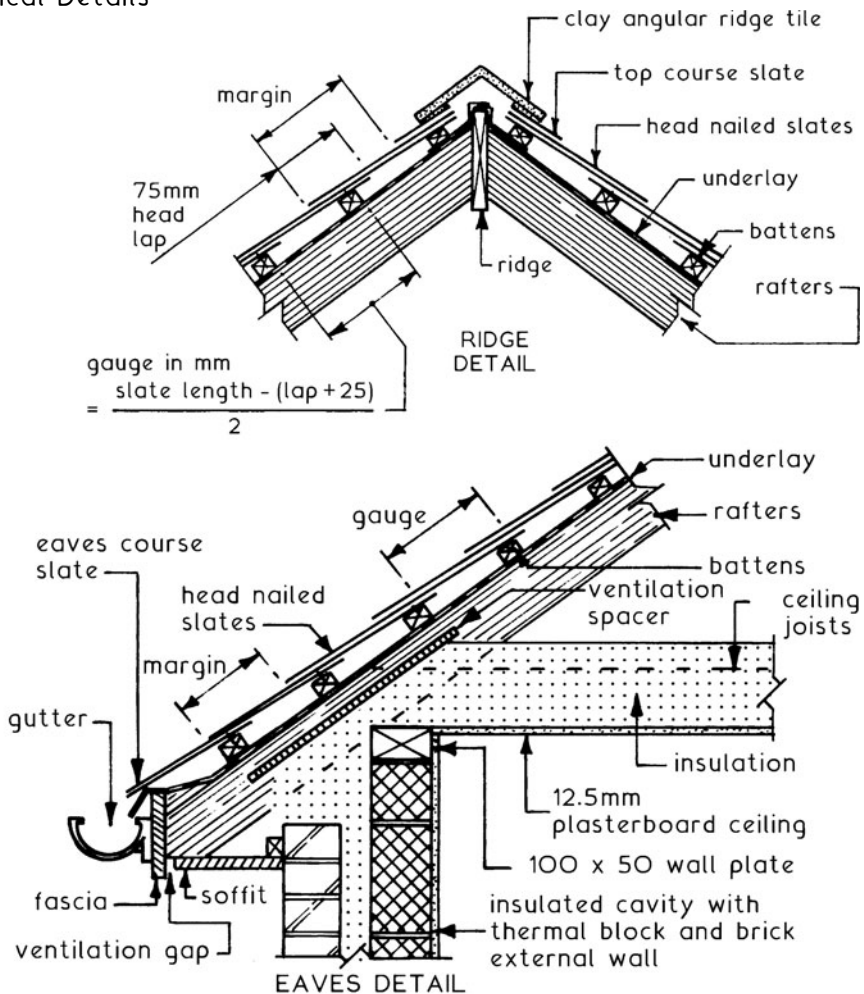

NB. Gauge for centre nailed slates = (slate length - lap) ÷ 2.

The UK has been supplied with its own slate resources from quarries in Wales, Cornwall and Westermorland. Imported slate is also available from Spain, Argentina and parts of the Far East.

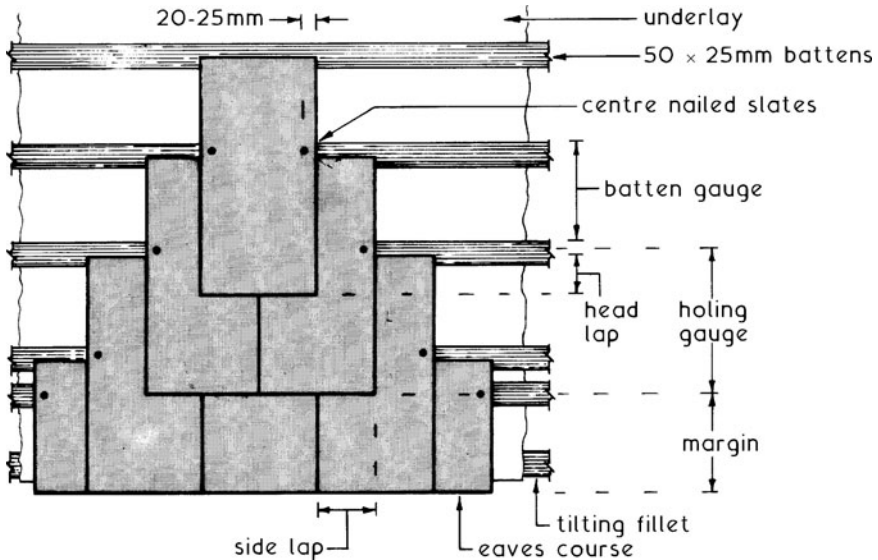

e.g. Countess slate, 510 × 255 mm laid to a 30° pitch with 75 mm head lap.

$$\begin{aligned} \text{Batten gauge} &= (\text{slate length} - \text{lap}) \div 2 \\ &= (510 - 75) \div 2 = 218 \text{ mm.} \end{aligned}$$

$$\begin{aligned} \text{Holing gauge} &= \text{batten gauge} + \text{head lap} + 8 \text{ to } 15 \text{ mm,} \\ &= 218 + 75 + (8 \text{ to } 15 \text{ mm}) = 301 \text{ to } 308 \text{ mm.} \end{aligned}$$

$$\text{Side lap} = 255 \div 2 = 127 \text{ mm.}$$

$$\text{Margin} = \text{batten gauge of } 218 \text{ mm.}$$

$$\text{Eaves course length} = \text{head lap} + \text{margin} = 293 \text{ mm.}$$

## Roof Slating

Traditional slate names and sizes (mm) -

Empress	650 × 400	Wide Viscountess	460 × 255
Princess	610 × 355	Viscountess	460 × 230
Duchess	610 × 305	Wide Ladies	405 × 255
Small Duchess	560 × 305	Broad Ladies	405 × 230
Marchioness	560 × 280	Ladies	405 × 205
Wide Countess	510 × 305	Wide Headers	355 × 305
Countess	510 × 255	Headers	355 × 255
.. . . .	510 × 230	Small Ladies	355 × 203
.. . . .	460 × 305	Narrow Ladies	355 × 180

Sizes can also be cut to special order.

Generally, the larger the slate, the lower the roof may be pitched. Also, the lower the roof pitch, the greater the head lap.

Slate quality	Thickness (mm)	Weight at 75mm head lap (kg/m <sup>2</sup> )
Best	4	26
Medium strong	5	Thereafter in proportion to thickness
Heavy	6	
Extra heavy	9	

Roof pitch (degrees)	Min. head lap (mm)
20	115
25	85
35	75
45	65

See also:

1. BS EN 12326-1: Slate and stone products for discontinuous roofing and cladding. Product specification.
2. Slate producers' catalogues.
3. BS 5534: Code of practice for slating and tiling.

Roof hip examples -

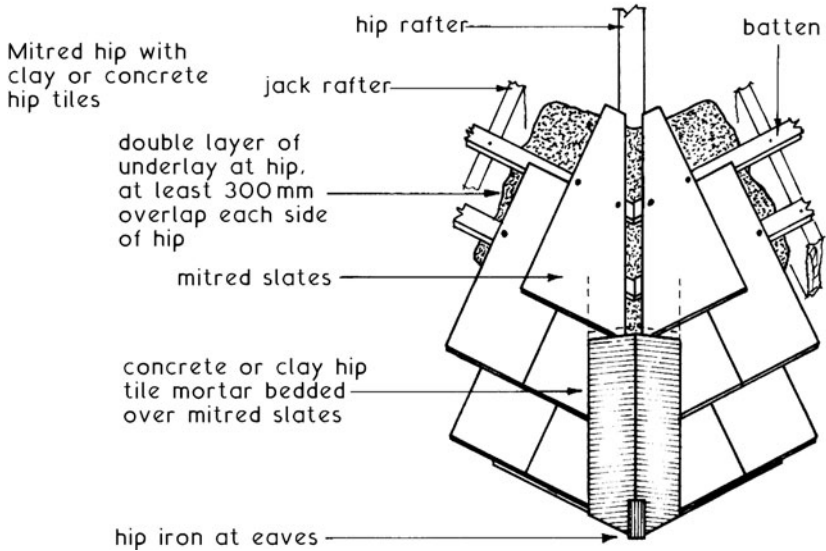
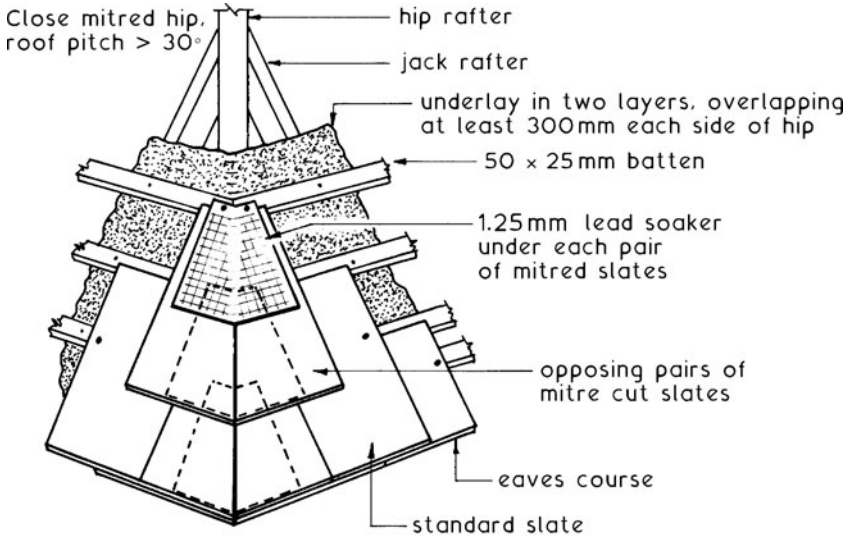

# Roof Slating – Applications

## Roof valley examples -

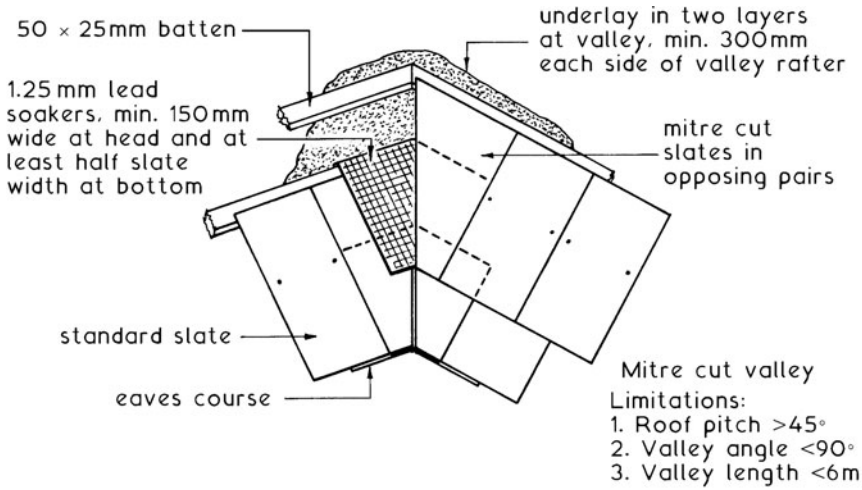

## Alternatives

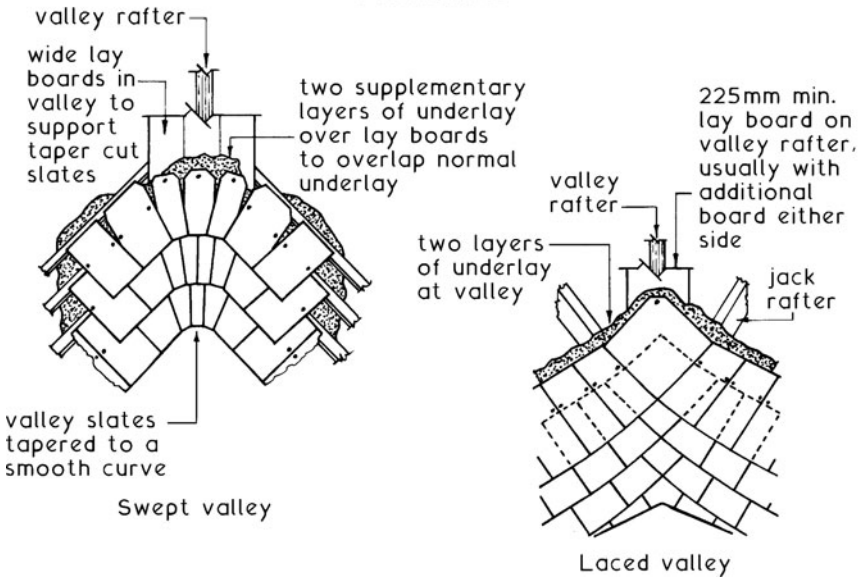

NB. In swept valleys, cut and tapered slates are interleaved with 1.25 mm lead soakers.

Materials - water reed (Norfolk reed), wheat straw (Spring or Winter), Winter being the most suitable. Wheat for thatch is often known as wheat reed, long straw or Devon reed. Other thatches include rye and oat straws, and sedge. Sedge is harvested every fourth year to provide long growth, making it most suitable as a ridging material.

There are various patterns and styles of thatching, relating to the skill of the thatcher and local traditions.

Typical details -

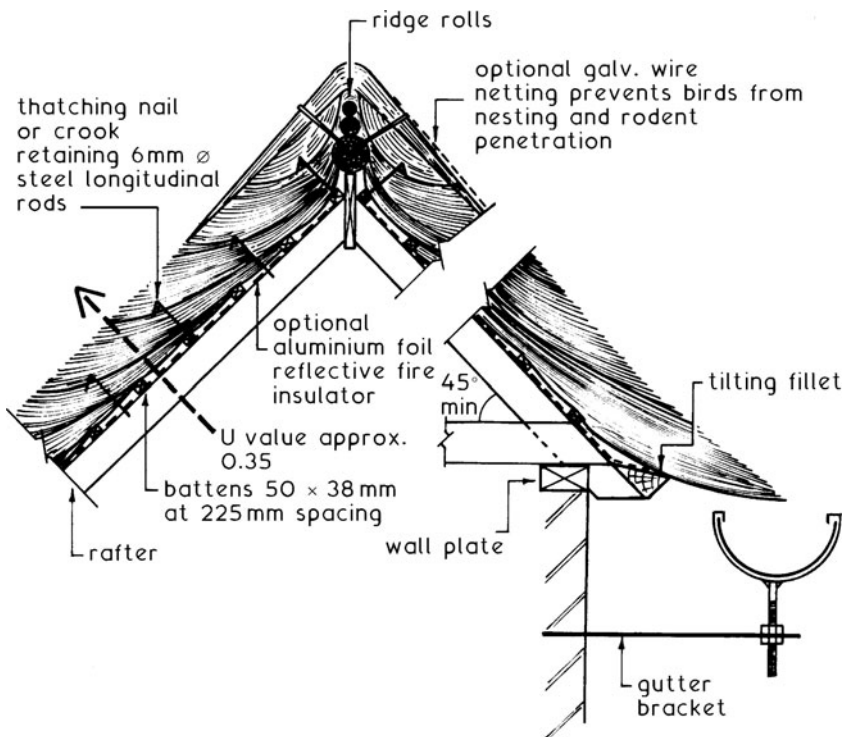

The material composition of thatch with its natural voids and surface irregularities provides excellent insulation when dry and compact. However, when worn with possible accumulation of moss and rainwater, the U-value is less reliable. Thatch is also very vulnerable to fire. Therefore, in addition to imposing a premium, insurers may require application of a surface fire retardant and a fire insulant underlay.

## Timber Flat Roofs up to 4m Span

Flat Roofs ~ these roofs are very seldom flat with a pitch of  $0^\circ$  but are considered to be flat if the pitch does not exceed  $10^\circ$ . The actual pitch chosen can be governed by the roof covering selected and/or by the required rate of rainwater discharge off the roof. As a general rule the minimum pitch for smooth surfaces such as asphalt should be 1:80 or  $0^\circ-43'$  and for sheet coverings with laps 1:60 or  $0^\circ-57'$ .

Methods of Obtaining Falls ~

### 1. Joists cut to falls

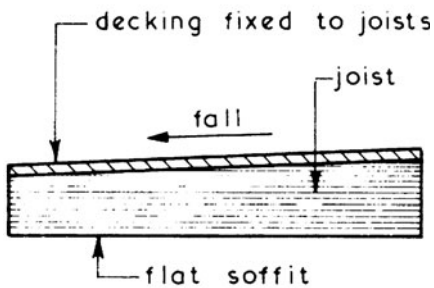

Simple to fix but could be wasteful in terms of timber unless two joists are cut from one piece of timber

### 2. Joists laid to falls

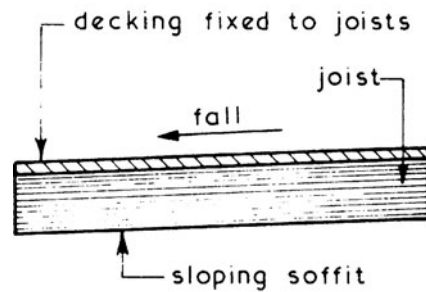

Economic and simple but sloping soffit may not be acceptable, but this could be hidden by a flat suspended ceiling

### 3. Firrings with joist run

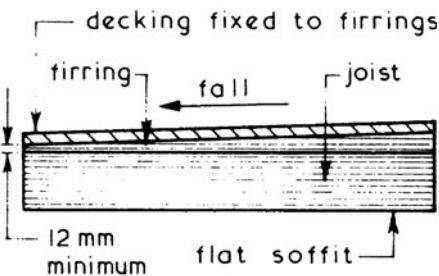

Simple and effective but does not provide a means of natural cross ventilation. Usual method employed.

### 4. Firrings against joist run

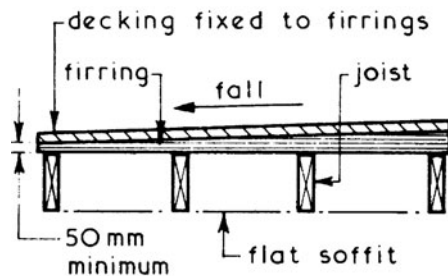

Simple and effective but uses more timber than 3 but does provide a means of natural cross ventilation

Wherever possible joists should span the shortest distance of the roof plan.

Timber Roof Joists ~ the spacing and sizes of joists is related to the loadings and span, actual dimensions for domestic loadings can be taken direct from recommendations in Approved Document A or they can be calculated as shown for timber beam designs. Strutting between joists should be used if the span exceeds 2.400 to restrict joist movements and twisting.

Typical Eaves Details ~

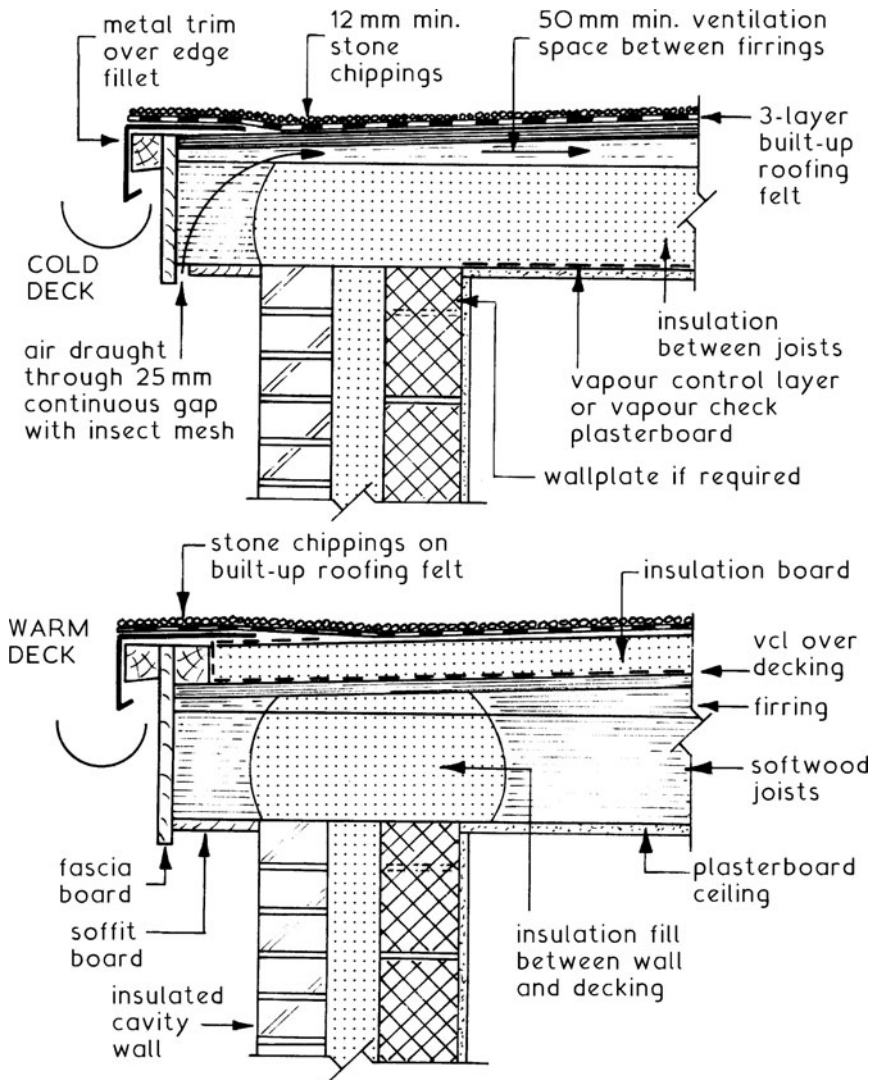

Ref. BS EN 13707: Flexible sheets for waterproofing. Reinforced bitumen sheets for roof waterproofing. Definitions and characteristics.



## Timber Flat Roofs (2)

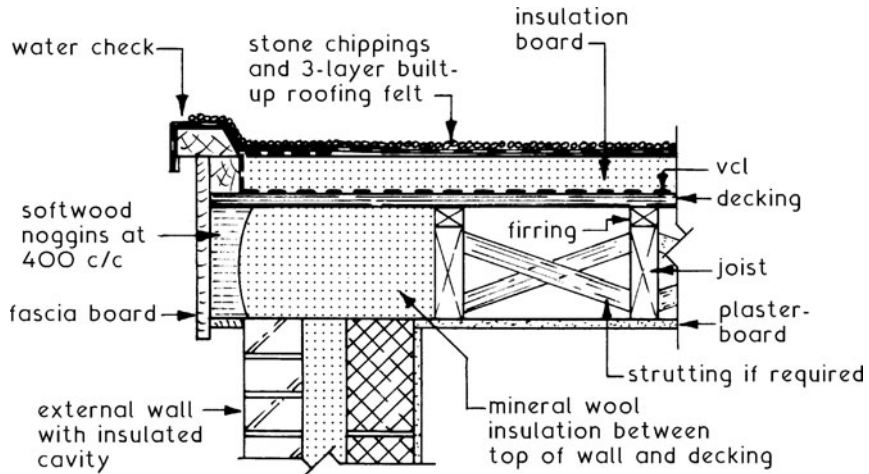

TYPICAL VERGE DETAILS - WARM DECK

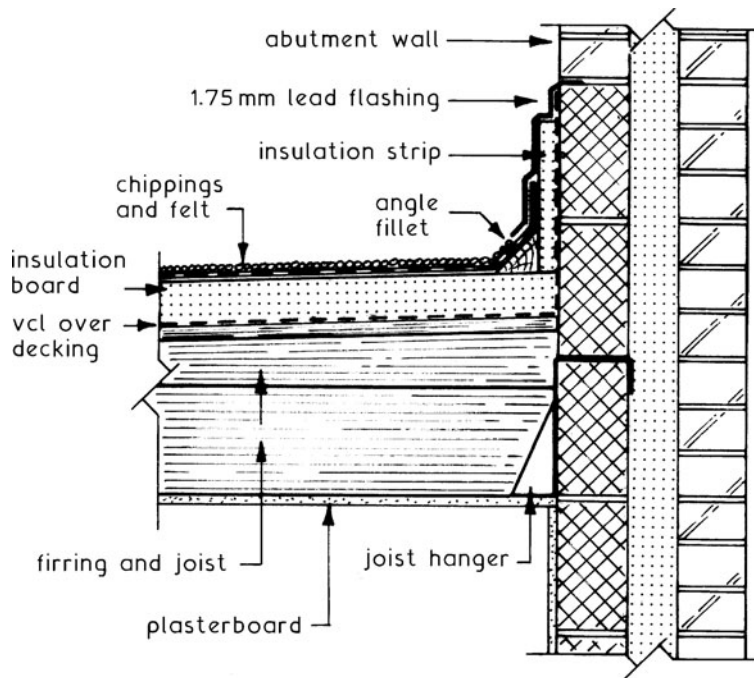

TYPICAL ABUTMENT DETAILS - WARM DECK

Ref. BS 8217: Reinforced bitumen membranes for roofing. Code of practice.

Further details ~

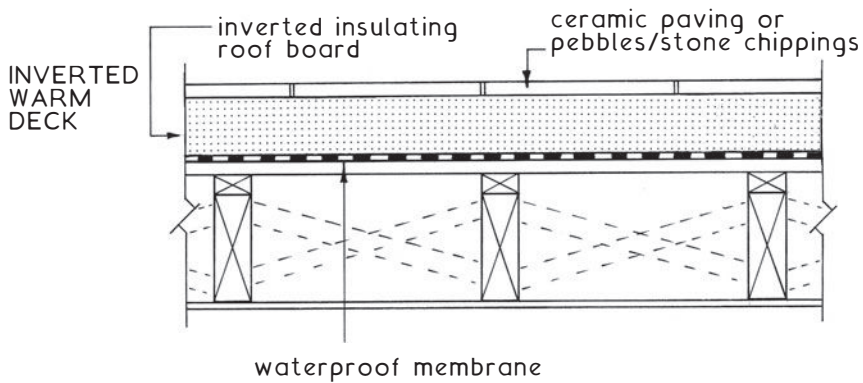
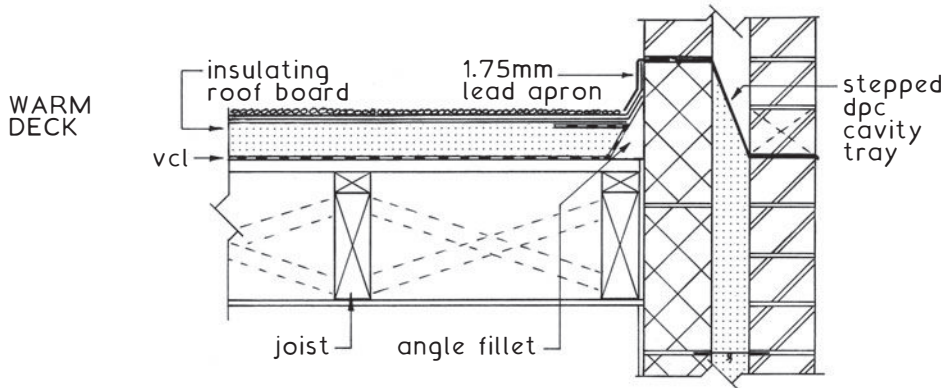
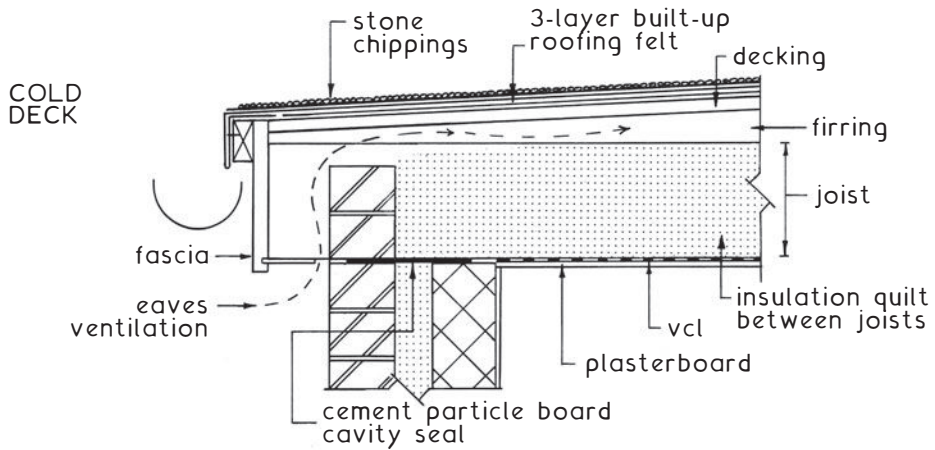

Note: Insulation type and thickness varies with application and situation.

## Timber Flat Roofs – Joist Sizes

Typical spans and loading for flat roof joists of general structural (GS) grade ~

Dead weight of decking and ceiling, excluding the self-weight of the joists (kg/m<sup>2</sup>)

< 50

50-75

75-100

Spacing of joists (mm c/c)

Sawn size (mm x mm)	Maximum clear span (m)								
	< 50			50-75			75-100		
	400	450	600	400	450	600	400	450	600
38 x 125	1.80	1.79	1.74	1.74	1.71	1.65	1.68	1.65	1.57
38 x 150	2.35	2.33	2.27	2.27	2.25	2.18	2.21	2.18	2.09
38 x 175	2.88	2.85	2.77	2.77	2.74	2.64	2.68	2.64	2.53
38 x 200	3.47	3.43	3.29	3.33	3.28	3.16	3.21	3.16	3.02
38 x 225	4.08	4.03	3.71	3.90	3.84	3.56	3.75	3.66	3.43
50 x 125	2.06	2.05	2.00	2.00	1.98	1.93	1.95	1.93	1.86
50 x 150	2.68	2.65	2.59	2.59	2.58	2.47	2.51	2.47	2.38
50 x 175	3.27	3.25	3.14	3.14	3.10	2.99	3.04	2.99	2.86
50 x 200	3.93	3.86	3.61	3.76	3.70	3.47	3.62	3.56	3.35
50 x 225	4.60	4.47	4.07	4.38	4.30	3.91	4.21	4.13	3.78
63 x 100	1.67	1.66	1.63	1.63	1.61	1.57	1.59	1.93	1.86
63 x 125	2.31	2.29	2.24	2.24	2.21	2.15	2.17	2.15	2.07
63 x 150	2.98	2.95	2.87	2.87	2.84	2.74	2.78	2.74	2.63
63 x 175	3.62	3.59	3.41	3.48	3.43	3.28	3.36	3.30	3.16
63 x 200	4.34	4.29	3.90	4.15	4.08	3.75	3.99	3.92	3.62
63 x 225	5.00	4.82	4.39	4.82	4.64	4.22	4.62	4.48	4.08
75 x 125	2.50	2.48	2.42	2.42	2.40	2.32	2.35	2.32	2.24
75 x 150	3.23	3.19	3.11	3.11	3.07	2.96	3.00	2.96	2.84
75 x 175	3.91	3.87	3.61	3.75	3.69	3.47	3.61	3.55	3.35
75 x 200	4.66	4.53	4.13	4.45	4.36	3.97	4.28	4.20	3.84
75 x 225	5.28	5.09	4.65	5.09	4.90	4.47	4.92	4.74	4.32

Notes:

1. See pages 38 and 39 for material dead weights.
2. See pages 141 and 142 for softwood classification and grades.

Timber Boards ~ traditional decking, rarely used now as manufactured composite boards are less expensive in material cost and installation time. Softwood boards should be at least 19mm finished thickness on joists spaced at up to 450mm centres. Tongued and grooved boards are preferred to plain edge boards as butt jointed plain edge boards may tend to warp and deform. Boards should be tightly clamped, securely nailed with nail heads punched below the surface. Countersunk screw fixings are an alternative.

Plywood ~ exterior grade boarding often specified as WBP (water boiled proof), a reference to the bonding quality of the adhesive securing the ply veneers. Fixed on all four edges, requiring noggins/struts between the joists. BS EN 636.

Particle Boards ~ general term for a variety of board materials derived from wood shavings and parings. Fixed with nails or screws as appropriate, as indicated for plywood.

Wood chipboard - Susceptible to movement and possibly decay if exposed to dampness. Therefore should be specified as moisture resistant to BS EN 312 types C3, C4 or C5. Usually identified by a dull green colour. Available pre-felted, i.e. with a factory-applied bituminous felt layer.

Oriented strand board (OSB) - a favoured alternative to chipboard as it is more stable in moist conditions. BS EN 300 types 3 and 4.

Cement bonded particle board - another alternative that has a high density and greater moisture resistance than other particle boards. BS EN 634-2.

Woodwool Slabs ~ composed of wood fibre shreds bonded together with cement. Produced in a variety of thicknesses, but for roof decking the minimum thickness is 50mm to satisfy strength requirements when accessed. Widths of 600mm are produced in lengths up to 4m. BS EN 13168.

Further information on composite board materials is on pages 860 and 861.

## Timber Flat Roofs – Thermal Insulation

Conservation of Energy ~ this can be achieved in two ways:

1. Cold Deck – insulation is placed on the ceiling lining, between joists. See pages 523 and 525 for details. A metallised polyester lined plasterboard ceiling functions as a vapour control layer, with a minimum 50 mm air circulation space between insulation and decking. The air space corresponds with eaves vents and both provisions will prevent moisture buildup, condensation and possible decay of timber.
2. (a) Warm Deck – rigid\* insulation is placed below the waterproof covering and above the roof decking. The insulation must be sufficient to maintain the vapour control layer and roof members at a temperature above dewpoint, as this type of roof does not require ventilation.  
  
(b) Inverted Warm Deck – rigid\* insulation is positioned above the waterproof covering. The insulation must be unaffected by water and capable of receiving a stone dressing or ceramic pavings.

\* Resin bonded mineral fibre roof boards, expanded polystyrene or polyurethane slabs.

Typical Warm Deck Details ~

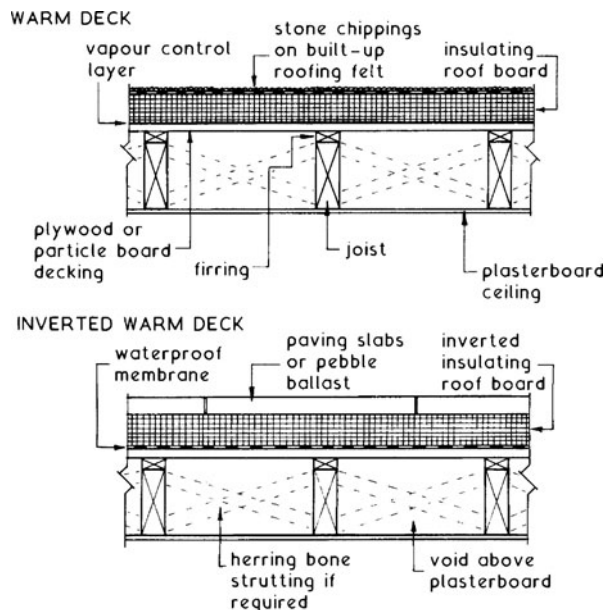

Material ~ bitumen is found naturally in ground deposits on its own or as a component of asphalt. It is also produced during distillation of crude oil.

Composition ~ originally based on rag fibres as reinforcement to hot bitumen impregnated during manufacture. Modern bituminous felts have a matrix of glass fibre or polyester matting as reinforcement to a stabilising bitumen coating on both sides. These materials provide an effective binding and have superseded rags as a more robust base. The upper surface is lightly coated with sand or fine mineral granules to prevent the sheet from sticking to itself when rolled. Standard dimensions are rolls of 1m width in lengths of 8 to 10 m. Thickness varies depending on specification, but is usually about 3 to 4mm. During manufacture some polymer modification is included with the bitumen. This is to reduce rigidity, making the material more flexible, workable and durable. Additives can be elastomers of atactic-polypropylene (APP) or styrene-butadiene-styrene (SBS).

Application ~ multi-layers, usually three, preferably in material specified to BS EN 13707 and laid to the recommendations of BS 8217. The first layer is laid at right angles to the fall commencing at the eaves. If the decking is timber, plywood or a wood composite, the first layer can be secured with large flat head nails, subsequent layers bonded together with hot molten bitumen. Side laps are at least 50 mm with 75 mm minimum laps at upper and lower ends. A variation known as torch-on is for use with specially made sheet. This is heated to the underside to produce a wave of molten bitumen as the sheet is unrolled. Timber product decking is not suitable for torch-on applications due to the fire risk, unless the surface is pre-felted and taped.

Finish ~ limestone, light-coloured shingle or granite chippings of 10 to 12 mm are suitable as weatherproofing, protection from solar radiation and resistance to fire. These are bonded to the surface with a cold or hot molten bitumen solution.

## Timber Flat Roof Coverings – Mastic Asphalt

Composition ~ a natural fine-grained material from sedimentary deposits in parts of Derbyshire, Leicestershire and Shropshire. A variation mined mainly in France known as rock asphalt is extracted from bitumen impregnated sandstone and limestone. The base material is often modified to create a composite material. Additives include limestone to improve stability and oil to reduce hardness and brittleness. Synthetic or natural fibres can be added for reinforcement. For transportation and storage, asphalt is cast into blocks. On site the blocks are heated in a cauldron to about 200°C. Molten asphalt is transferred by bucket and spread manually with a wooden trowel.

Application ~ this consists of two layers of mastic asphalt laid breaking joints and built up to a minimum thickness of 20 mm and should be laid to the recommendations of BS 8218. The mastic asphalt is laid over an isolating membrane of black sheathing felt which should be laid loose with 50 mm minimum overlaps.

Typical Details ~

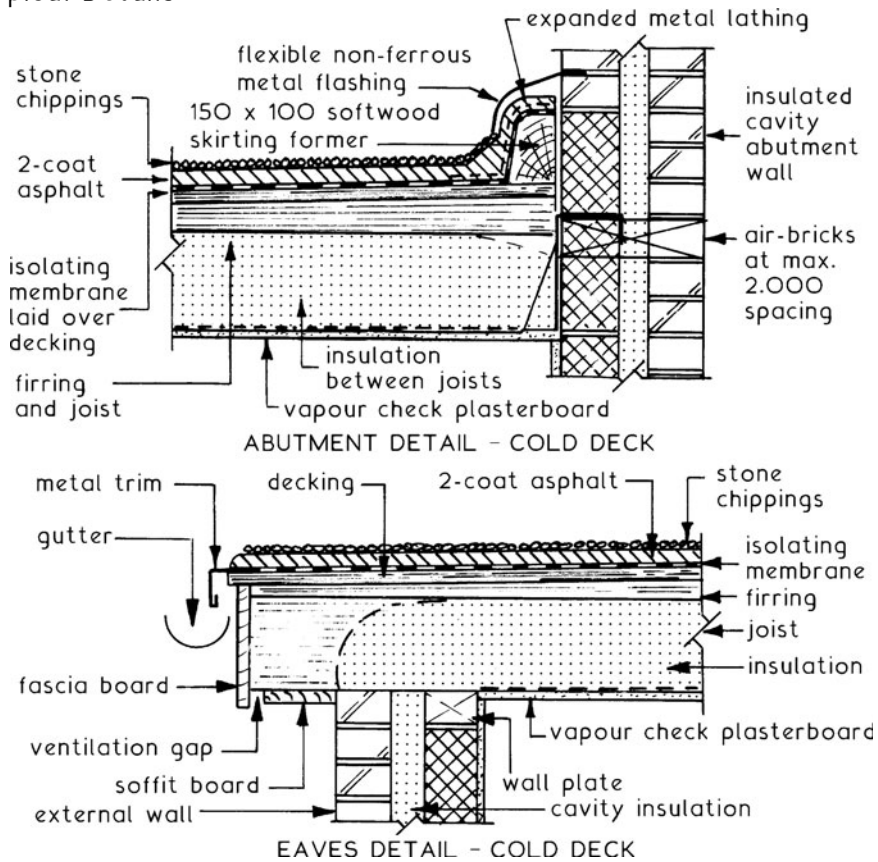

Ref. BS 8218: Code of practice for mastic asphalt roofing.

## Timber Flat Roof Coverings – Lead Sheet Specification

Milled Lead Sheet ~ produced from refined lead to an initial thickness of about 125 mm. Thereafter it is rolled and cut to 12.000 m lengths, 2.400 m wide into the following thicknesses and categories:

BS 1178* Code No.	BS EN 12588/standard milled thickness (mm)	Weight (kg/m <sup>2</sup> ) BS EN/milled	Colour marking
3	1.25/1.32	14.17/14.97	Green
-	1.50/1.59	17.00/18.03	Yellow
4	1.75/1.80	19.84/20.41	Blue
5	2.00/2.24	22.67/25.40	Red
6	2.50/2.65	28.34/30.05	Black
7	3.00/3.15	34.02/35.72	White
8	3.50/3.55	39.69/40.26	Orange

\*BS 1178: Specification for milled sheet lead and strip for building purposes. This BS has been superseded by BS EN 12588: Lead and lead alloys. Rolled lead sheet for building purposes. The former BS codes are replaced with lead sheet thicknesses between 1.25 and 3.50 millimetres. They are included here, as these codes remain common industry reference. Codes originated before metrication as the approximate weight of lead sheet in pounds per square foot (lb/ft<sup>2</sup>), e.g. 3lb/ft<sup>2</sup> became Code 3.

Other dimensions ~ cut widths between 75 mm and 600 mm in coils.

Density ~ approximately 11,325 kg/m<sup>3</sup>.

Application (colour marking) ~

Green and yellow – soakers.

Blue, red and black – flat roof covering in small, medium and large areas respectively (see table on page 534).

White and orange – lead lining to walls as protection from X-rays or for sound insulation, but can be used for relatively large areas of roof covering.



## Timber Flat Roof Coverings - Lead Sheet

Thermal Movement ~ the coefficient of linear expansion for lead is 0.0000297 ( $2.97 \times 10^{-6}$ ) for every degree Kelvin.

E.g. If the exposure temperature range throughout a year is from  $-10^{\circ}\text{C}$  to  $35^{\circ}\text{C}$  (45K), then a 2.000 m length of sheet lead could increase by:  $0.0000297 \times 45 \times 2 = 0.00267$  m, or 2.67 mm.

Over time this movement will cause fatigue stress, manifesting in cracking. To prevent fracture, a smooth surface underlay should be used and the areas of lead sheet limited with provision of joints designed to accommodate movement.

Underlay ~ placed over plywood or similar smooth surface decking, or over rigid insulation boards. Bitumen impregnated felt or waterproof building paper have been the established underlay, but for new work a non-woven, needle punched polyester textile is now generally preferred.

Fixings ~ clips, screws and nails of copper, brass or stainless steel.

Jointing ~ for small areas such as door canopies and dormers where there is little opportunity for thermal movement, a simply formed welt can be used if the depth of rainwater is unlikely to exceed the welt depth.

Welted joint

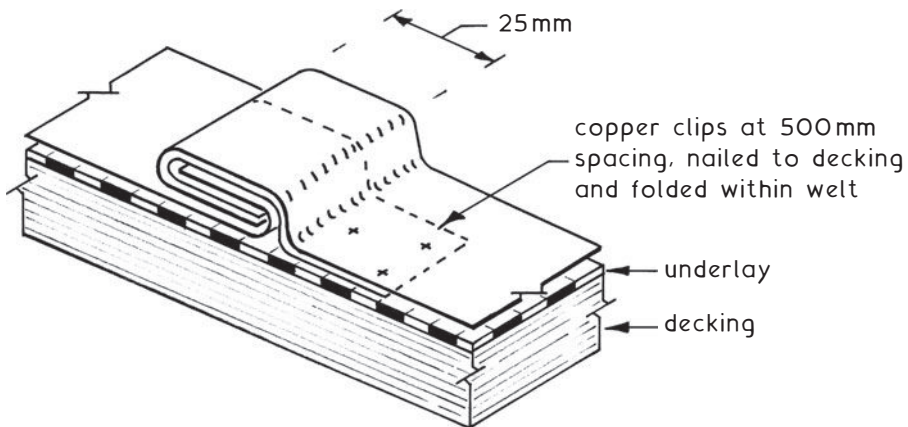

Jointing to absorb movement:

- Wood cored rolls in the direction of the roof slope (see next page).
- Drips at right angles to and across the roof slope (see next page).

Typical provision of wood cored rolls and drips - detail at junction

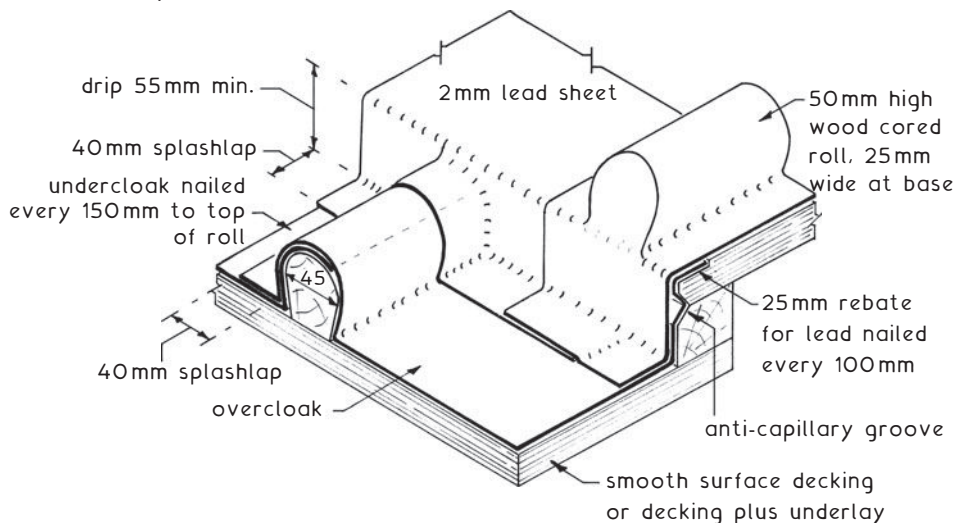

Lead is a soft and malleable material. A skilled craftsman (traditionally a plumber) can manipulate lead sheet with hand tools originally made from dense timber such as boxwood, but now produced from high-density polythene. This practice is known as 'bossing' the lead to the profiles shown. Alternatively, the lead sheet can be cut and welded to shape.

Selection of lead working tools ~

Dresser



Setting-in stick

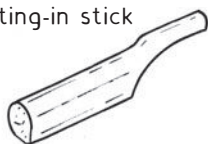

Chase wedge



Mallet

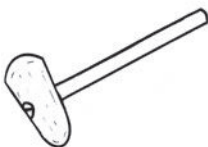

Bossing stick

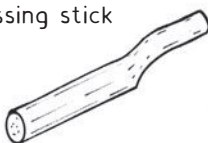

Bending stick



## Timber Flat Roof Coverings - Lead Sheet Application

Spacing of wood cored rolls and drips varies with the thickness specification of lead sheet. The following is a guide ~

BS EN 12588 thickness (mm)	Maximum distance between drips (mm) [A]	Maximum distance between rolls (mm) [B]
1.25 and 1.50	Use for soakers only	
1.75	1500	500
2.00	2000	600
2.50	2250	675
3.00	2500	675
3.50	3000	750

Typical flat roof plan (page 491)

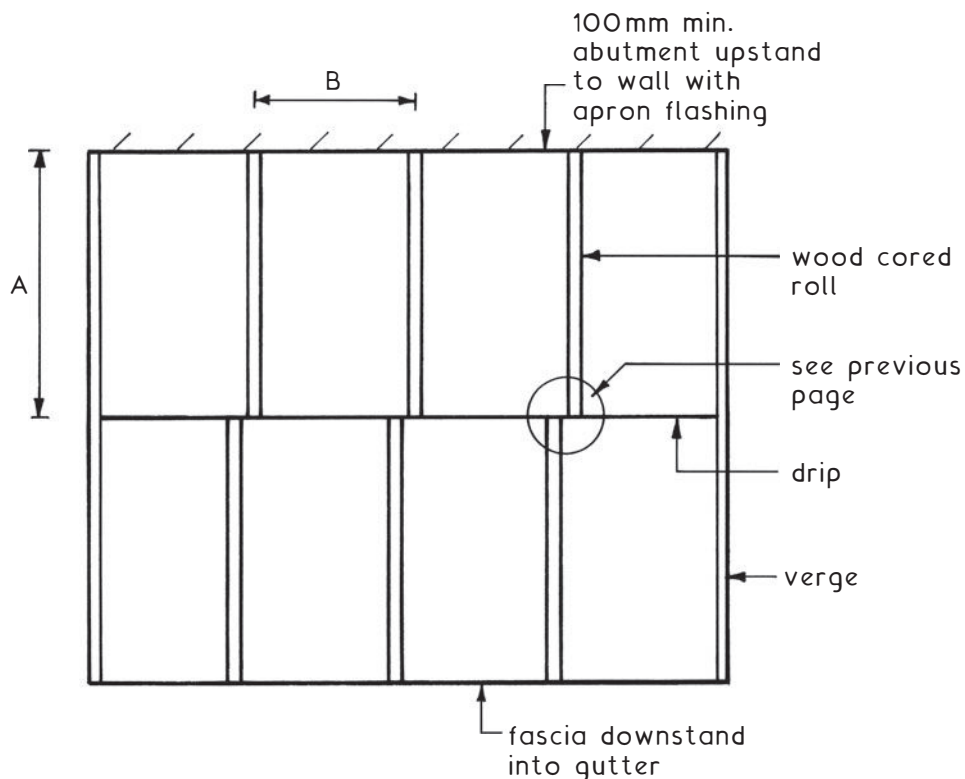

## Timber Flat Roofs - Single Ply Membranes

Single Ply Membranes ~ durable, resilient, flexible and lightweight sheet materials composed mainly of synthetic polymers. Some are reinforced with glass fibres depending on application and coverage area. A backing of glass fibre or polyester matting is often provided as a bonding interface.

Thickness ~ generally between 1 and 2 mm.

Fixing ~ product manufacturer's recommended adhesive applied to the sub-surface. Purpose made mechanical fixing devices are an alternative in situations that may be exposed to wind lift.

Materials ~ Polyvinyl chloride (PVC).

Thermoplastics: Thermoplastic polyolefin (TPO).

Chlorinated polyethylene (CPE).

Ethylene interpolymer (EIP).

Copolymer alloy (CPA).

Acrylonitrile butadiene polymer (NBP).

Other Considerations ~

- PVC membranes can be solvent adhesive bonded at overlaps or hot air welded.
- Thermoplastics are hot air welded at seams and overlaps (homogenous jointing at about 400 to 500°C).
- Ethylene propylene diene monomer (EPDM) is a thermoset synthetic rubber that can only be adhesive sealed. Application of heat would physically break it down.

Typical Detail ~

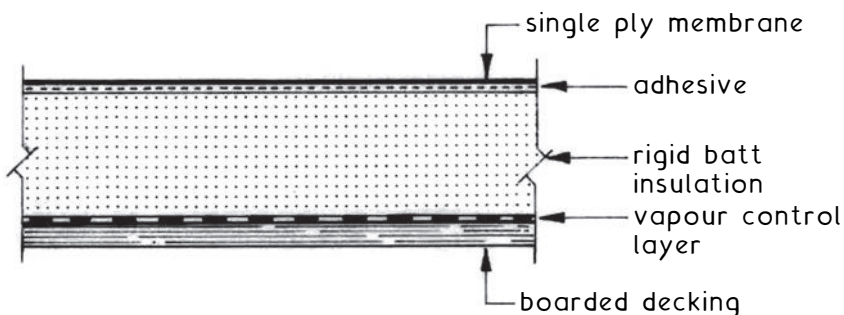

Note: 'Warm deck' shown. 'Cold deck' construction details on pages 523 and 525.

# Timber Flat Roofs - Single Ply Membrane Details

## Application

hand held low voltage electric element welder (see note below)

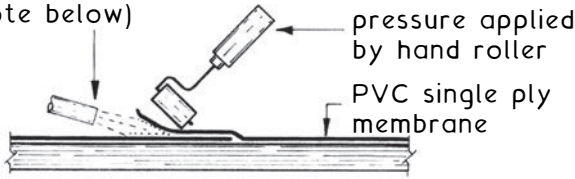

## Side lap

150mm

## End lap

100mm

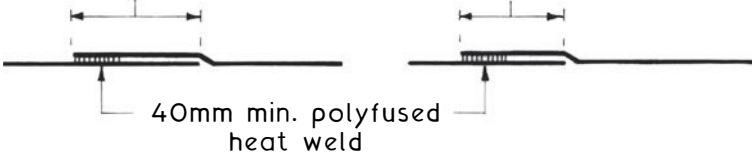

## Eaves

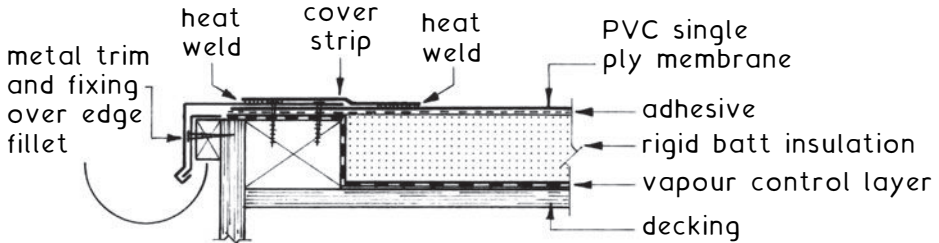

## Abutment

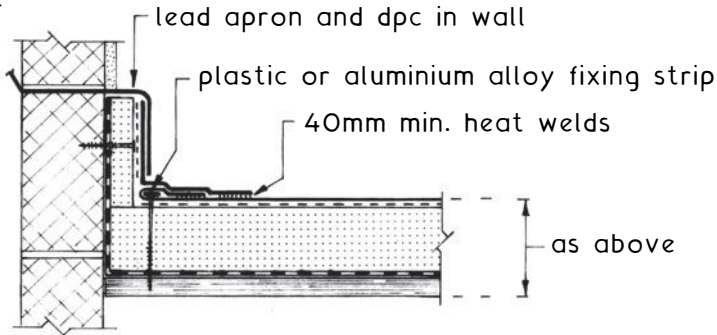

## Notes:

- Hand held welder and roller used mainly for small detail areas. Automatic (manually directed) welder/roller more effective for continuous seaming.
- See Note re. warm and cold deck construction on preceding page.

A dormer is the framework for a vertical window constructed from the roof slope. It may be used as a feature, but is more likely as an economical and practical means for accessing light and ventilation to an attic room. Dormers are normally external with the option of a flat or pitched roof. Frame construction is typical of the following illustrations, with connections made by traditional housed and tenoned joints or simpler galvanised steel brackets and hangers.

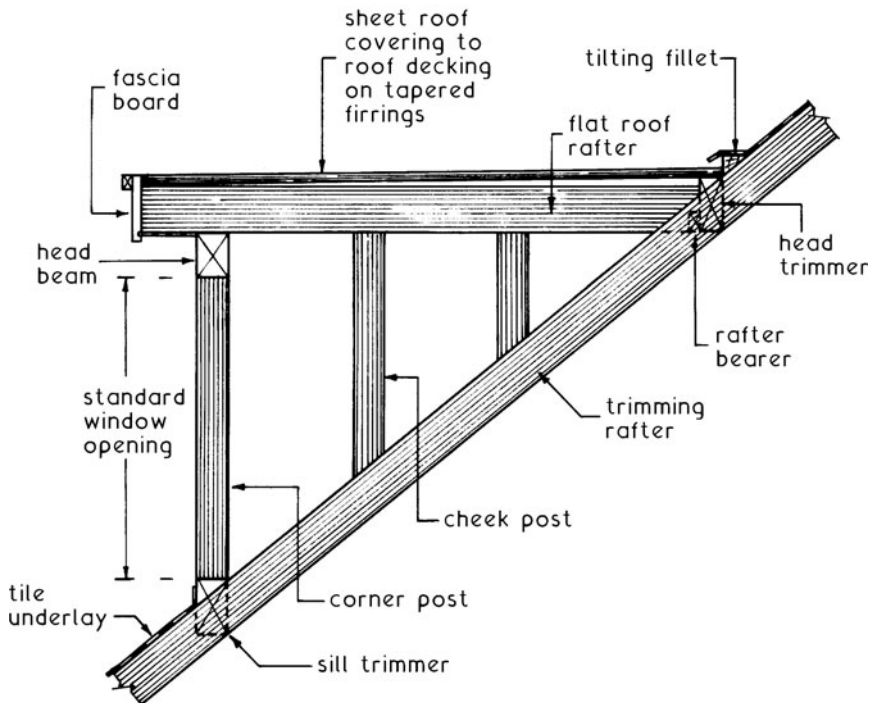
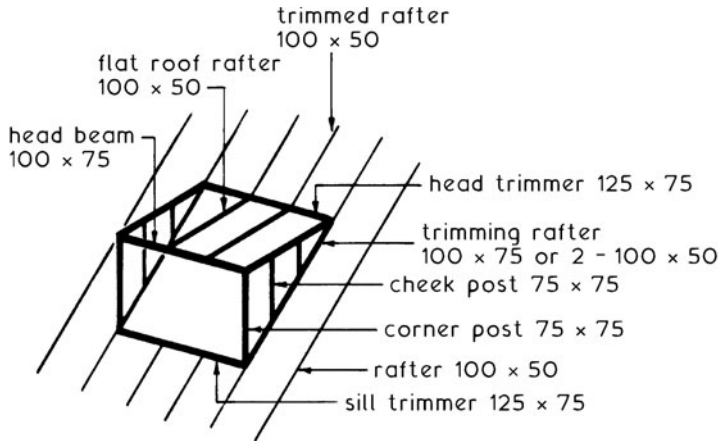

# Dormer Window Types

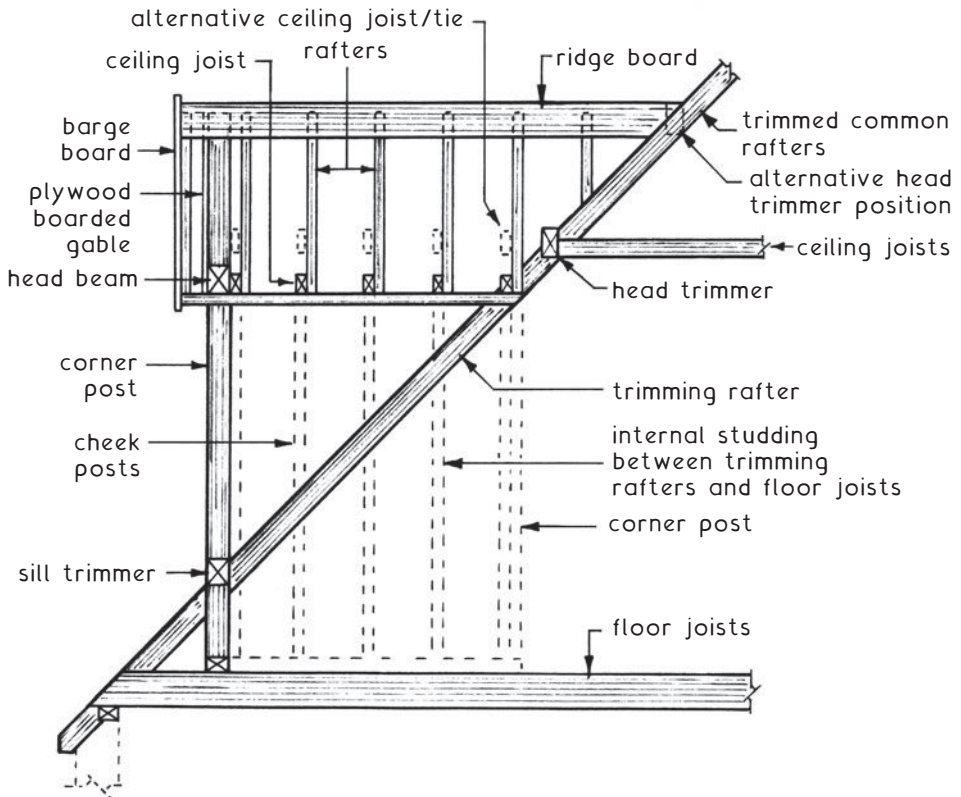
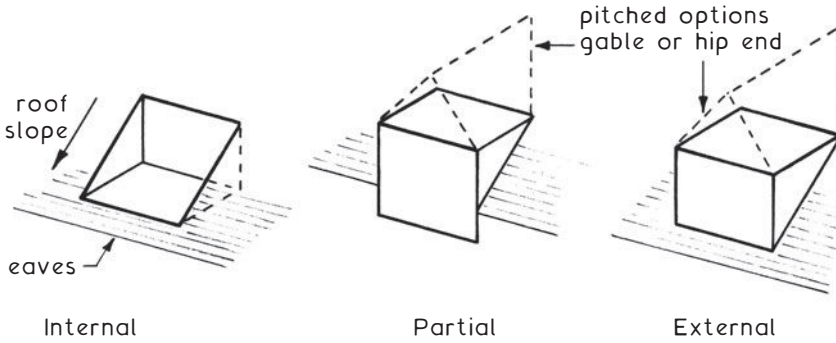

Section through gable ended external dormer

A graceful interruption to the routine of a pitched roof, derived from thatched roofs where the thatch is swept over window openings. Other suitable coverings are timber shingles, plain tiles and small slates.

Main roof pitch  $\geq 50^\circ$ . Eyebrow pitch  $\geq 35^\circ$ .

Transition curve should be smooth with span to height ratio  $> 8:1$ . Less is possible, but may prove impractical and disproportionate.

Possible profile ~

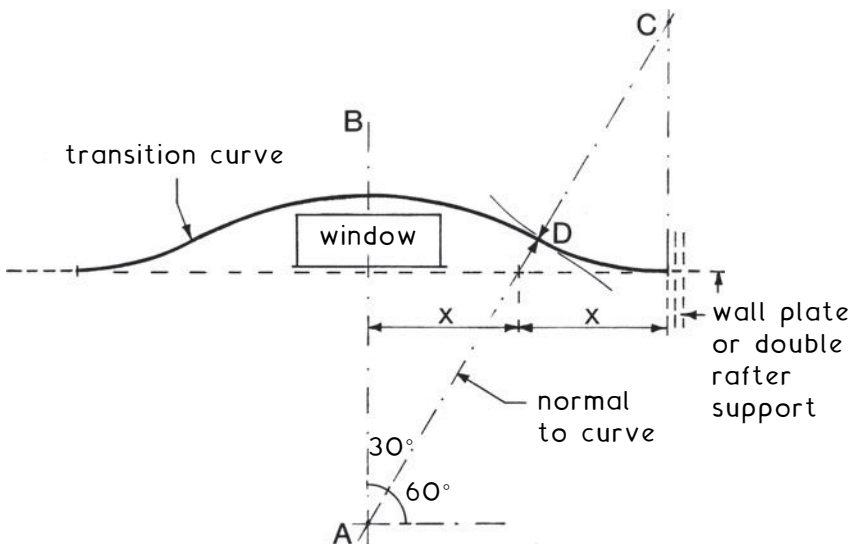

A-B is a line through the centre of the window opening.

A-D radius is positioned to clear the window head.

C-D radius is established near window base in continuity to A-D.

A purpose-made glulam beam can be used to create the transition curve, effectively extending the wall plate to receive the eyebrow rafters. The curved beam for an intermediate eyebrow may be supported on joist hangers to double trimming rafters each side.



## Ventilation of Roof Spaces (1)

Air carries water vapour, the amount increasing proportionally with the air temperature. As the water vapour increases so does the pressure and this causes the vapour to migrate from warmer to cooler parts of a building. As the air temperature reduces, so does its ability to hold water and this manifests as condensation on cold surfaces. Insulation between living areas and roof spaces increases the temperature differential and potential for condensation in the roof void.

Condensation can be prevented by either of the following:

- \* Providing a vapour control layer on the warm side of any insulation.
- \* Removing the damp air by ventilating the colder area.

The most convenient form of vapour layer is vapour check plasterboard which has a moisture resistant lining bonded to the back of the board. A typical patented product is a foil or metallised polyester backed plasterboard in 9.5 and 12.5 mm standard thicknesses. This is most suitable where there are rooms in roofs and for cold deck flat roofs. Ventilation is appropriate to larger roof spaces.

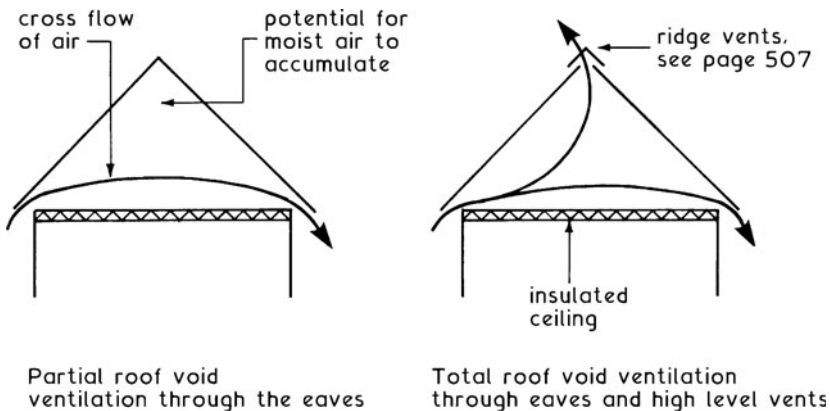

## Ventilation of Roof Spaces (2)

Roof Ventilation - provision of eaves ventilation alone should allow adequate air circulation in most situations. However, in some climatic conditions and where the air movement is not directly at right angles to the building, moist air can be trapped in the roof apex. Therefore, supplementary ridge ventilation is recommended.

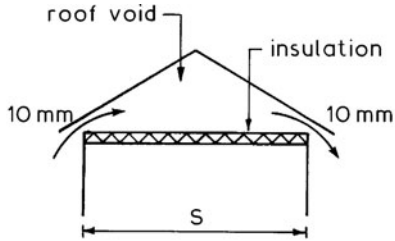

Insulation at ceiling level (1)  
S = span <10m for  
roof pitches 15°-35°

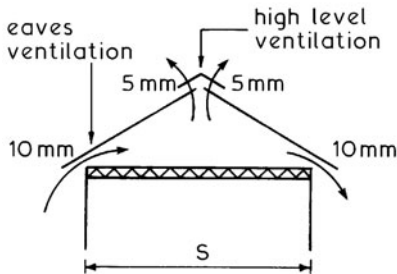

Insulation at ceiling level (2)  
S = span >10m for  
roof pitches 15°-35°  
Any span for roof  
pitches >35°

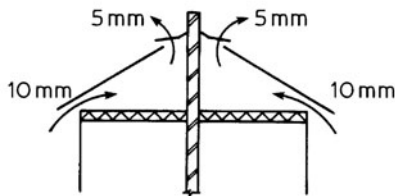

Insulation at ceiling level and  
central dividing wall  
Roof pitches >15°  
for any span

NB. Ventilation dimensions shown relate to a continuous strip (or equivalent) of at least the given gap.

### Ventilation of Roof Spaces (3)

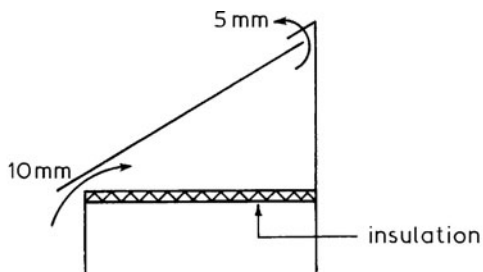

Mono-pitch or lean-to roof  
Roof pitch  $>15^\circ$ , any span

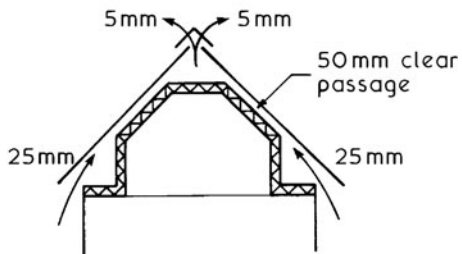

Room within roof void  
All pitches and spans

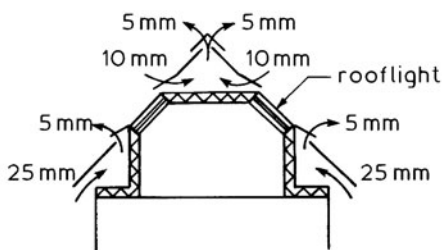

Room within roof void with  
obstructions  
All pitches, all spans

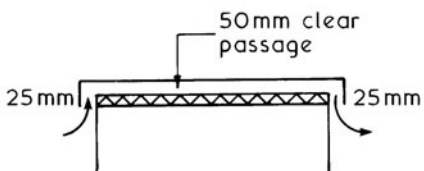

Flat roof

Refs.: Building Regulations, Approved Document C - Site preparation and resistance to contaminants and moisture. Section 6 - Roofs.  
BS 5250: Code of practice for control of condensation in buildings.

BRE report - Thermal Insulation: avoiding risks (3rd. edn).

Lateral Restraint - stability of gable walls and construction at the eaves, plus integrity of the roof structure during excessive wind forces, requires complementary restraint and continuity through 30 x 5 mm cross-sectional area galvanised steel straps.

Exceptions may occur if the roof:

1. exceeds 15° pitch, and
2. is tiled or slated, and
3. has the type of construction known locally to resist gusts, and
4. has ceiling joists and rafters bearing onto support walls at not more than 1.2 m centres.

Application ~

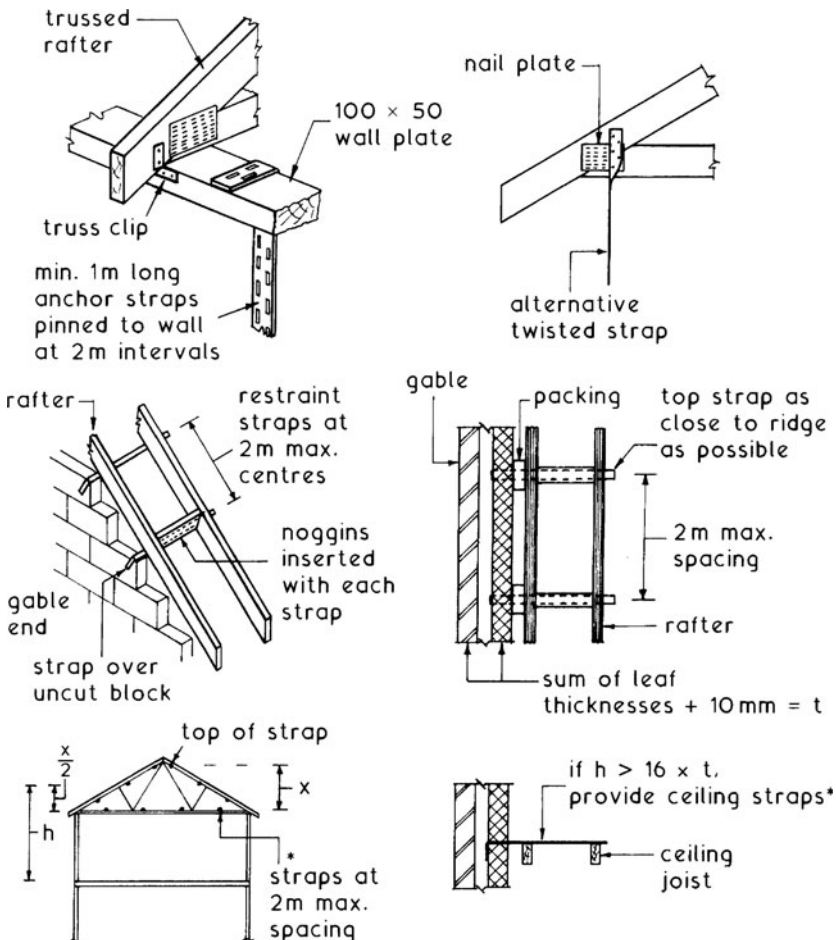

## Timber Roofs – Preservation

Preservation ~ ref. Building Regulations: Materials and Workmanship. Approved Document to support Regulation 7.

Woodworm infestation of untreated structural timbers is common. However, the smaller woodborers such as the abundant Furniture beetle are controllable. It is the threat of considerable damage potential from the House Longhorn beetle that has forced many local authorities in Surrey and the fringe areas of adjacent counties to seek timber preservation listing in the Building Regulations (see Table 1 in the above reference). Prior to the introduction of pretreated timber (c. 1960s), the House Longhorn beetle was once prolific in housing in the south of England, establishing a reputation for destroying structural roof timbers, particularly in the Camberley area.

House Longhorn beetle data:

Latin name - *Hylotrupes bajulus*

Life cycle - Mature beetle lays up to 200 eggs on rough surface of untreated timber.

After two to three weeks, larvae emerge and bore into wood, preferring sapwood to denser growth areas. Up to 10 years in the damaging larval stage. In three weeks, larvae change to chrysalides to emerge as mature beetles in summer to reproduce.

Timber appearance - powdery deposits (frass) on the surface and the obvious mature beetle flight holes.

Beetle appearance -

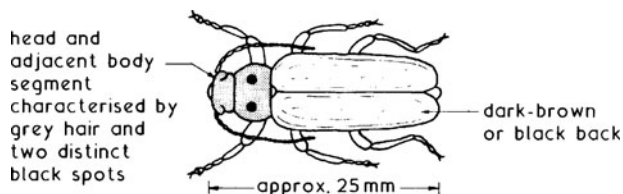

Other woodborers:

Furniture beetle - dark brown, 6-8 mm long, lays 20-50 eggs on soft or hardwoods. Boreholes only 1-2 mm diameter.

Lyctus powder post beetle - reddish brown, 10-15 mm long, lays 70-200 eggs on sapwood of new hardwood. Boreholes only 1-2 mm in diameter.

Death-watch beetle - dark brown, sometimes speckled in lighter shades. Lays 40-80 eggs on hardwood. Known for preferring the oak timbers used in old churches and similar buildings.

Boreholes about 3 mm diameter.

Preservation ~ treatment of timber to prevent damage from House Longhorn beetle.

In the areas specified (see previous page), all softwood used in roof structures including ceiling joists and any other softwood fixings should be treated with insecticide prior to installation. Specific chemicals and processes have not been listed in the Building Regulations since the 1976 issue. Timber treatment then was either:

- Vacuum/pressure impregnation with a blend of copper, chromium and arsenic (CCA), known commercially as 'tanalising'.
- Diffusion with sodium borate (boron salts).
- Steeping (min. 10 mins.) in organic solvent wood preservative.
- Steeping or soaking in tar oil (creosote). This has limitations due to staining of adjacent surfaces.

The current edition of Approved Document A (Structure) to the Building Regulations refers to guidance on preservative treatments in the British Wood Preserving and Damp-Proofing Association's Manual. Other guidance is provided in:

BS 5707: Specification for preparation for wood preservatives in organic solvents.

BS 8417: Preservation of wood. Code of practice.

BS EN 117: Wood preservatives.

Insect treatment adds about 10% to the cost of timber and also enhances its resistance to moisture. Other parts of the structure (e.g. floors and partitions) are less exposed to woodworm damage as they are enclosed. Also, there is a suggestion that if these areas received treated timber, the toxic fumes could be harmful to the health of building occupants. Current requirements for through ventilation in roofs have the added benefit of discouraging wood boring insects, as they prefer draught-free damp areas.

Note: EU directive CEN/TC 38 prohibits the use of CCA preservative for domestic applications and in places where the public may be in contact with it.

## Green Roofs

Green roof ~ green with reference to the general appearance of plant growths and for being environmentally acceptable. Part of the measures for constructing sustainable and ecologically friendly buildings.

Categories:

- Extensive ~ a relatively shallow soil base (typically 50 mm) and lightweight construction. Maximum roof pitch is 40° and slopes greater than 20° will require a system of baffles to prevent the soil moving. Plant life is limited by the shallow soil base to grasses, mosses, herbs and sedum (succulents, generally with fleshy leaves producing pink or white flowers).
- Intensive ~ otherwise known as a roof garden. This category has a deeper soil base (typically 400 mm) that will provide for landscaping features, small ponds, occasional shrubs and small trees. A substantial building structure is required for support and it is only feasible to use a flat roof.

Advantages:

- Absorbs and controls water run-off.
- Integral thermal insulation.
- Integral sound insulation.
- Absorbs air pollutants, dust and CO<sub>2</sub>.
- Passive heat storage potential.

Disadvantages:

- Weight.
- Maintenance.

Construction ~ the following buildup will be necessary to fulfil the objectives and to create stability:

- Vapour control layer above the roof structure.
- Rigid slab insulation.
- Root resilient waterproof under-layer.
- Drainage layer.
- Filter.
- Growing medium (soil).
- Vegetation (grass, etc.)

NB. Examples of both extensive and intensive green roof construction are shown on the next page.

Typical extensive roof buildup ~

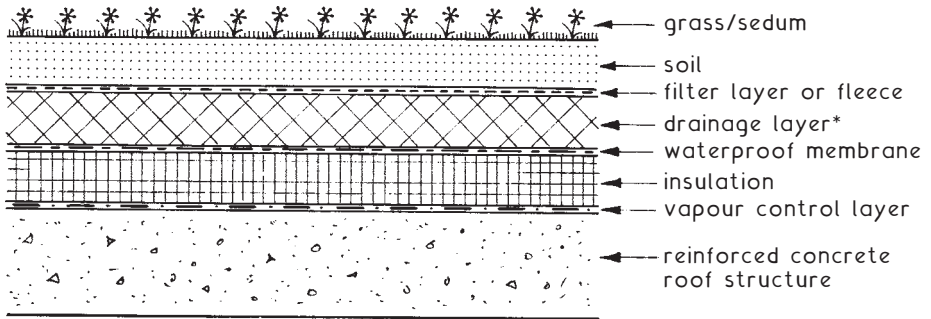

\* typically, expanded polystyrene with slots

Component	Weight (kg/m <sup>2</sup> )	Thickness (mm)
vcl	3	3
insulation	3	50
membrane	5	5
drainage layer	3	50
filter	3	3
soil	90	50
turf	40	20
-----		-----
	147 kg/m <sup>2</sup>	181 mm

147 kg/m<sup>2</sup> saturated weight x 9.81 = 1442 N/m<sup>2</sup> or 1.44 kN/m<sup>2</sup>

Typical intensive roof buildup ~

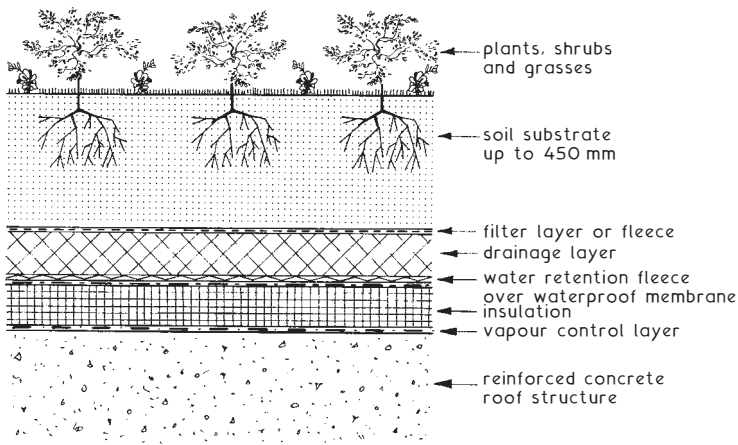

Depth to vcl, approximately 560 mm at about 750 kg/m<sup>2</sup> saturated weight. 750 kg/m<sup>2</sup> x 9.81 = 7358 N/m<sup>2</sup> or 7.36 kN/m<sup>2</sup>.



## Thermal Insulation, U-Value Calculations (1)

Thermal insulation of external elements of construction is measured in terms of thermal transmittance rate, otherwise known as the U-value. It is the amount of heat energy in watts transmitted through one square metre of construction for every one degree Kelvin between external and internal air temperature, i.e. W/m<sup>2</sup>K.

U-values are unlikely to be entirely accurate, due to:

- \* the varying effects of solar radiation, atmospheric dampness and prevailing winds.
- \* inconsistencies in construction, even with the best of supervision.
- \* 'bridging' where different structural components meet, e.g. dense mortar in lightweight blockwork.

Nevertheless, calculation of the U-value for a particular element of construction will provide guidance as to whether the structure is thermally acceptable. The Building Regulations, Approved Document L, Conservation of fuel and power, determines acceptable energy efficiency standards for modern buildings, with the objective of limiting the emission of carbon dioxide and other burnt gases into the atmosphere.

The U-value is calculated by taking the reciprocal of the summed thermal resistances (R) of the component parts of an element of construction:

$$U = \frac{1}{\sum R} = \text{W/m}^2\text{K}$$

R is expressed in m<sup>2</sup>K/W. The higher the value, the better a component's insulation. Conversely, the lower the value of U, the better the insulative properties of the structure.

Building Regulations, Approved Document references:

L1A, Work in new dwellings.

L1B, Work in existing dwellings.

L2A, Work in new buildings other than dwellings.

L2B, Work in existing buildings other than dwellings.

## Thermal Insulation, U-Value Calculations (2)

Thermal resistances (R) are a combination of the different structural, surface and air space components which make up an element of construction. Typically:

$$U = \frac{1}{R_{so} + R_1 + R_2 + R_a + R_3 + R_4 \text{ etc.} + R_{si}} \text{ (m}^2\text{K/W)}$$

Where:  $R_{so}$  = Outside or external surface resistance.

$R_1, R_2, \text{ etc.}$  = Thermal resistance of structural components.

$R_a$  = Air space resistance, e.g. wall cavity.

$R_{si}$  = Internal surface resistance.

The thermal resistance of a structural component ( $R_1, R_2, \text{ etc.}$ ) is calculated by dividing its thickness (L) by its thermal conductivity ( $\lambda$ ), i.e.

$$R(\text{m}^2\text{K/W}) = \frac{L(\text{m})}{\lambda(\text{W/mK})}$$

E.g. 1. A 102 mm brick with a conductivity of 0.84 W/mK has a thermal resistance (R) of:  $0.102 \div 0.84 = 0.121 \text{ m}^2\text{K/W}$ .

E.g. 2.

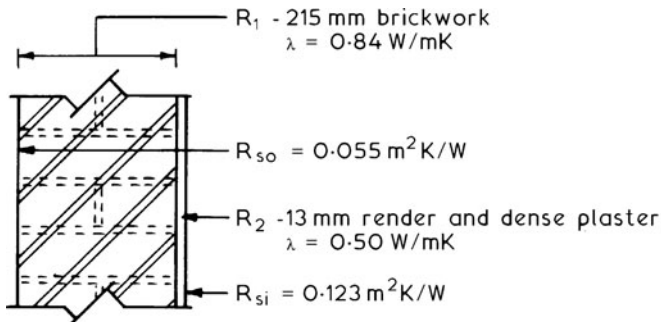

NB. the effect of mortar joints in the brickwork can be ignored, as both components have similar density and insulative properties.

$$U = \frac{1}{R_{so} + R_1 + R_2 + R_{si}}$$

$$R_1 = 0.215 \div 0.84 = 0.256$$

$$R_2 = 0.013 \div 0.50 = 0.026$$

$$U = \frac{1}{0.055 + 0.256 + 0.026 + 0.123} = 2.17 \text{ W/m}^2\text{K}$$

## Thermal Insulation, Surface and Air Space Resistances

Typical values in:  $\text{m}^2\text{K}/\text{W}$

Internal surface resistances ( $R_{si}$ ):

Walls - 0.123

Floors or ceilings for upward heat flow - 0.104

Floors or ceilings for downward heat flow - 0.148

Roofs (flat or pitched) - 0.104

External surface resistances ( $R_{so}$ ):

Surface	Exposure		
	Sheltered	Normal	Severe
Wall - high emissivity	0.080	0.055	0.030
Wall - low emissivity	0.110	0.070	0.030
Roof - high emissivity	0.070	0.045	0.020
Roof - low emissivity	0.090	0.050	0.020
Floor - high emissivity	0.070	0.040	0.020

Sheltered - town buildings to 3 storeys.

Normal - town buildings 4 to 8 storeys and most suburban premises.

Severe - > 9 storeys in towns.

> 5 storeys elsewhere and any buildings on exposed coasts and hills.

Air space resistances ( $R_a$ ):

Pitched or flat roof space - 0.180

Behind vertical tile hanging - 0.120

Cavity wall void - 0.180

Between high and low emissivity surfaces - 0.300

Unventilated/sealed - 0.180

Emissivity relates to the heat transfer across and from surfaces by radiant heat emission and absorption effects. The amount will depend on the surface texture, the quantity and temperature of air movement across it, the surface position or orientation and the temperature of adjacent bodies or materials. High surface emissivity is appropriate for most building materials. An example of low emissivity would be bright aluminium foil on one or both sides of an air space.

## Thermal Insulation, Density and Thermal Conductivity (1)

Typical values -		
Material	Density (kg/m <sup>3</sup> )	Conductivity ( $\lambda$ ) (W/mK)
<b>WALLS:</b>		
Boarding (hardwood)	700	0.18
..... (softwood)	500	0.13
Brick outer leaf	1700	0.84
... inner leaf	1700	0.62
Calcium silicate board	875	0.17
Ceramic tiles	2300	1.30
Concrete	2400	1.93
.....	2200	1.59
.....	2000	1.33
.....	1800	1.13
..... (lightweight)	1200	0.38
..... (reinforced)	2400	2.50
Concrete block (lightweight)	600	0.18
..... (mediumweight)	1400	0.53
Cement mortar (protected)	1750	0.88
..... (exposed)	1750	0.94
Fibreboard	350	0.08
Gypsum plaster (dense)	1300	0.57
Gypsum plaster (lightweight)	600	0.16
Plasterboard	950	0.16
Tile hanging	1900	0.84
Rendering	1300	0.57
Sandstone	2600	2.30
Wall ties (st/st)	7900	17.00
<b>ROOFS:</b>		
Aerated concrete slab	500	0.16
Asphalt	1900	0.60
Bituminous felt in 3 layers	1700	0.50
Sarking felt	1700	0.50
Stone chippings	1800	0.96
Tiles (clay)	2000	1.00
... (concrete)	2100	1.50
Wood wool slab	500	0.10

## Thermal Insulation, Density and Thermal Conductivity (2)

Typical values -

Material	Density (kg/m <sup>3</sup> )	Conductivity ( $\lambda$ ) (W/mK)
<b>FLOORS:</b>		
Cast concrete	2000	1.33
Hardwood block/strip	700	0.18
Plywood/particle board	650	0.14
Screed	1200	0.41
Softwood board	500	0.13
Steel tray	7800	50.00
<b>INSULATION:</b>		
Expanded polystyrene board	20	0.035
Mineral wool batt/slab	25	0.038
Mineral wool quilt	12	0.042
Phenolic foam board	30	0.025
Polyurethane board	30	0.025
Urea formaldehyde foam	10	0.040
<b>GROUND:</b>		
Clay/silt	1250	1.50
Sand/gravel	1500	2.00
Homogeneous rock	3000	3.50

Notes:

1. For purposes of calculating U-values, the effect of mortar in external brickwork is usually ignored as the density and thermal properties of bricks and mortar are similar.
2. Where butterfly wall ties are used at normal spacing in an insulated cavity  $\leq 75$  mm, no adjustment is required to calculations. If vertical twist ties are used in insulated cavities  $>75$  mm, 0.020 W/m<sup>2</sup>K should be added to the U-value.
3. Thermal conductivity ( $\lambda$ ) is a measure of the rate that heat is conducted through a material under specific conditions (W/mK).

## Thermal Insulation, Methods for Determining U-Values

- \* Tables and charts - Insulation manufacturers' design guides and technical papers (walls, roofs and ground floors).
- \* Calculation using the Proportional Area Method (walls and roofs).
- \* Calculation using the Combined Method - BS EN ISO 6946 (walls and roofs).
- \* Calculation using BS EN ISO 13370 (ground floors and basements).

Tables and charts - these apply where specific U-values are required and standard forms of construction are adopted. The values contain appropriate allowances for variable heat transfer due to different components in the construction, e.g. twisted pattern wall ties and non-uniformity of insulation with the interruption by ceiling joists. The example below shows the tabulated data for a solid ground floor with embedded insulation of  $\lambda = 0.03 \text{ W/mK}$ :

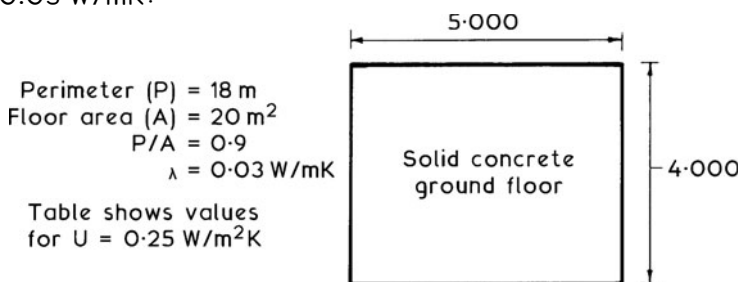

Typical table for floor insulation:

P/A	0.020	0.025	0.030*	0.035	0.040	0.045	W/mK
1.0	61	76	91	107	122	137	mm ins.
0.9*	60	75	<u>90</u>	105	120	135	.. ..
0.8	58	73	88	102	117	132	.. ..
0.7	57	71	85	99	113	128	.. ..
0.6	54	68	82	95	109	122	.. ..
0.5	51	64	77	90	103	115	.. ..

90 mm of insulation required.

Refs.: BS EN ISO 6946: Building components and building elements. Thermal resistance and thermal transmittance. Calculation method.

BS EN ISO 13370: Thermal performance of buildings. Heat transfer via the ground. Calculation methods.

## Thermal Insulation, Calculating U-Values (1)

Various applications to different ground floor situations are considered in BS EN ISO 13370. The following is an example of a solid concrete slab in direct contact with the ground. The data used is from the previous page.

Floor section

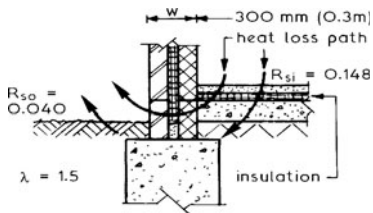

Perimeter = 18 m (exposed)

Floor area = 20m<sup>2</sup>

$\lambda$  for 90 mm insulation = 0.03 W/mK

Characteristic floor dimension = B<sup>1</sup>

B<sup>1</sup> = Floor area  $\div$  (1/2 exp. perimeter)

B<sup>1</sup> = 20  $\div$  9 = 2.222m

Formula to calculate total equivalent floor thickness for uninsulated and insulated all over floor:

$$dt = w + \lambda (R_{si} + R_f + R_{so})$$

where:  $dt$  = total equivalent floor thickness (m)

$w$  = wall thickness (m)

$\lambda$  = thermal conductivity of soil (W/mK) [see page 552]

$R_{si}$  = internal surface resistance (m<sup>2</sup>K/W) [see page 550]

$R_f$  = insulation resistance (0.09  $\div$  0.03 = 3 m<sup>2</sup>K/W)

$R_{so}$  = external surface resistance (m<sup>2</sup>K/W) [see page 550]

Uninsulated:  $dt = 0.3 + 1.5 (0.148 + 0 + 0.04) = 0.582\text{m}$

Insulated:  $dt = 0.3 + 1.5 (0.148 + 3 + 0.04) = 5.082\text{m}$

Formulae to calculate U-values ~

Uninsulated or poorly insulated floor,  $dt < B^1$ :

$$U = (2\lambda) \div [(\pi B^1) + dt] \times \ln [(\pi B^1 \div dt) + 1]$$

Well insulated floor,  $dt \geq B^1$ :

$$U = \lambda \div [(0.457 \times B^1) + dt]$$

where:  $U$  = thermal transmittance coefficient (W/m<sup>2</sup>/K)

$\lambda$  = thermal conductivity of soil (W/mK)

B<sup>1</sup> = characteristic floor dimension (m)

$dt$  = total equivalent floor thickness (m)

ln = natural logarithm

Uninsulated floor ~

$$U = (2 \times 1.5) \div [(3.142 \times 2.222) + 0.582] \times \ln [(3.142 \times 2.222) \div 0.582 + 1]$$

$$U = 0.397 \times \ln 12.996 = 1.02 \text{ W/m}^2\text{K}$$

Insulated floor ~

$$U = 1.5 \div [(0.457 \times 2.222) + 5.082] = 1.5 \div 6.097 = 0.246 \text{ W/m}^2\text{K}$$

NB. Compares with the tabulated figure of 0.250 W/m<sup>2</sup>K on the previous page.

Proportional Area Method (Wall)

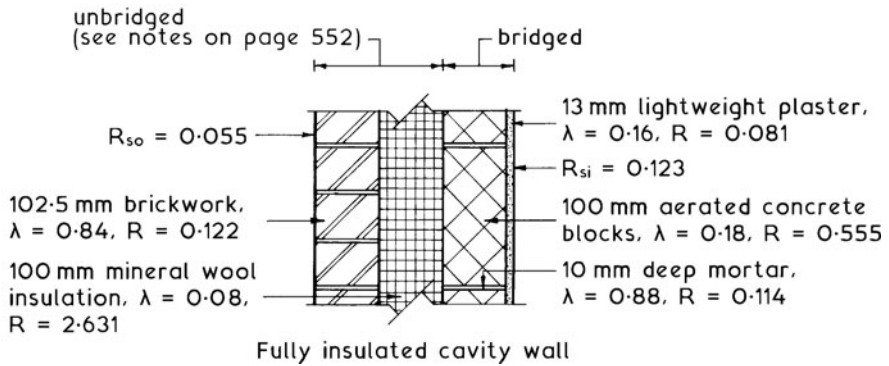

A standard block with mortar is  $450 \times 225 \text{ mm} = 101250 \text{ mm}^2$

A standard block format of  $440 \times 215 \text{ mm} = 94600 \text{ mm}^2$

The area of mortar per block =  $6650 \text{ mm}^2$

Proportional area of mortar =  $\frac{6650}{101250} \times \frac{100}{1} = 6.57\% (0.066)$

Therefore the proportional area of blocks =  $93.43\% (0.934)$

Thermal resistances (R):

Outer leaf + insulation (unbridged)

$R_{so} = 0.055$

brickwork = 0.122

insulation = 2.631

2.808

$\times 100\% = 2.808$

Inner leaf (unbridged)

blocks = 0.555

plaster = 0.081

$R_{si} = \underline{0.123}$

0.759

$\times 93.43\% = 0.709$

Inner leaf (bridged)

mortar = 0.114

plaster = 0.081

$R_{si} = \underline{0.123}$

= 0.318

$\times 6.57\% = 0.021$

$$U = \frac{1}{\sum R} = \frac{1}{2.808 + 0.709 + 0.021} = 0.283 \text{ W/m}^2\text{K}$$



## Thermal Insulation, Calculating U-Values (3)

### Combined Method (Wall)

This method considers the upper and lower thermal resistance (R) limits of an element of structure. The average of these is reciprocated to provide the U-value.

$$\text{Formula for upper and lower resistances} = \frac{1}{\Sigma(F_x \div R_x)}$$

Where:  $F_x$  = Fractional area of a section

$R_x$  = Total thermal resistance of a section

Using the wall example from the previous page:

Upper limit of resistance (R) through section containing blocks -  
( $R_{so}$ , 0.055) + (brkchk, 0.122) + (ins, 2.631) + (blocks, 0.555) + (plstr, 0.081) + ( $R_{si}$ , 0.123) = 3.567 m<sup>2</sup>K/W

Fractional area of section (F) = 93.43% or 0.934

Upper limit of resistance (R) through section containing mortar -  
( $R_{so}$ , 0.055) + (brkchk, 0.122) + (ins, 2.631) + (mortar, 0.114) + (plstr, 0.081) + ( $R_{si}$ , 0.123) = 3.126 m<sup>2</sup>K/W

Fractional area of section (F) = 6.57% or 0.066

The upper limit of resistance =

$$\frac{1}{\Sigma(0.943 \div 3.567) + (0.066 \div 3.126)} = 3.533 \text{ m}^2\text{K/W}$$

Lower limit of resistance (R) is obtained by summing the resistance of all the layers -

( $R_{so}$ , 0.055) + (brkchk, 0.122) + (ins, 2.631) + (bridged layer, 1 ÷ [0.934 ÷ 0.555] + [0.066 ÷ 0.114] = 0.442) + (plstr, 0.081) + ( $R_{si}$ , 0.123) = 3.454 m<sup>2</sup>K/W

Total resistance (R) of wall is the average of upper and lower limits = (3.533 + 3.454) ÷ 2 = 3.493 m<sup>2</sup>K/W

$$\text{U-value} = \frac{1}{R} = \frac{1}{3.493} = 0.286 \text{ W/m}^2\text{K}$$

NB. Both proportional area and combined method calculations require an addition of 0.020 W/m<sup>2</sup>K to the calculated U-value. This is for vertical twist type wall ties in the wide cavity. See page 400 and note 2 on page 552.

Proportional Area Method (Roof)

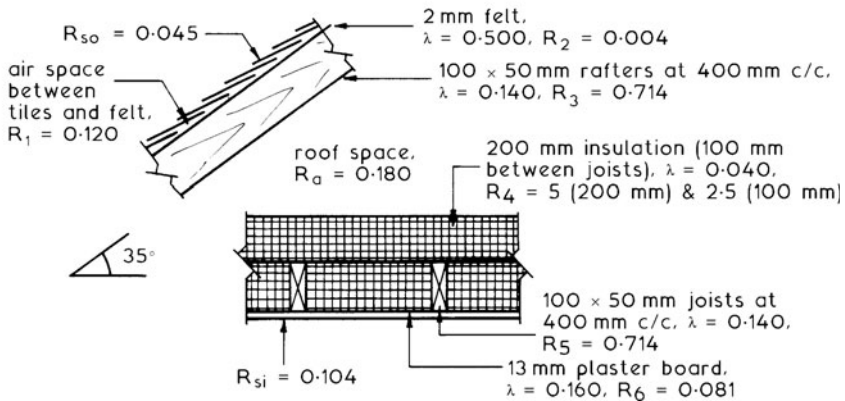

Notes:

1. The air space in the loft area is divided between pitched and ceiling components, i.e.  $R_a = 0.180 \div 2 = 0.090 \text{ m}^2\text{K/W}$ .
2. The U-value is calculated perpendicular to the insulation, therefore the pitched component resistance is adjusted by multiplying by the cosine of the pitch angle, i.e. 0.819.
3. Proportional area of bridging parts (rafters and joists) is  $50 \div 400 = 0.125$  or 12.5%.
4. With an air space resistance value ( $R_1$ ) of  $0.120 \text{ m}^2\text{K/W}$  between tiles and felt, the resistance of the tiling may be ignored.

Thermal resistance (R) of the pitched component:

Raftered part

$$R_{so} = 0.045$$

$$R_1 = 0.120$$

$$R_2 = 0.004$$

$$R_3 = 0.714$$

$$R_a = \underline{0.090}$$

$$0.973 \times 12.5\% = 0.122$$

Non-raftered part

$$R_{so} = 0.045$$

$$R_1 = 0.120$$

$$R_2 = 0.004$$

$$R_a = \underline{0.090}$$

$$0.259 \times 87.5\%$$

$$= 0.227$$

Total resistance of pitched components =

$$(0.122 + 0.227) \times 0.819 = 0.286 \text{ m}^2\text{K/W}$$

Thermal resistance (R) of the ceiling component:

Joisted part

$$R_{si} = 0.104$$

$$R_6 = 0.081$$

$$R_5 = 0.714$$

$$R_4 = 2.500 \text{ (100 mm)}$$

$$R_a = \underline{0.090}$$

$$3.489 \times 12.5\% = 0.436$$

Fully insulated part

$$R_{si} = 0.104$$

$$R_6 = 0.081$$

$$R_4 = 5.000 \text{ (200 mm)}$$

$$R_a = \underline{0.090}$$

$$5.275 \times 87.5\%$$

$$= 4.615$$

Total resistance of ceiling components =  $0.436 + 4.615$

$$= 5.051 \text{ m}^2\text{K/W}$$

$$U = \frac{1}{\Sigma R} = \frac{1}{0.286 + 5.051} = 0.187 \text{ W/m}^2\text{K}$$

## Thermal Insulation, Calculating U-Values (5)

Area weighted application ~ an allowance for a variation occurring in the construction of an external element.

E.g. Taking the roof U-value calculation shown on the previous page and including an uninsulated plywood loft hatch within the ceiling. The loft hatch occupies 10% of the overall ceiling area.

Ceiling/loft hatch section

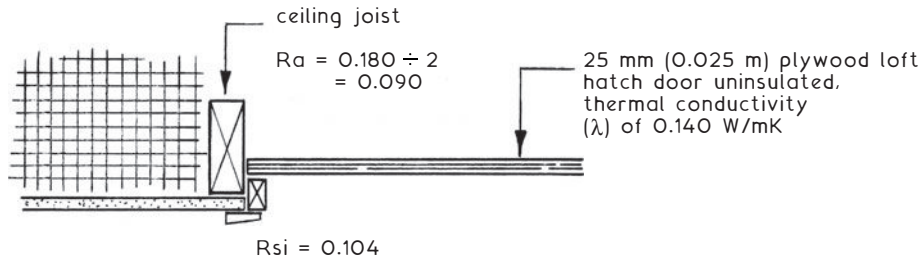

$$\begin{aligned}\text{Resistance (R) of hatch material} &= 0.025 \text{ m} \div 0.140 \text{ W/mK} \\ &= 0.178 \text{ m}^2\text{K/W}\end{aligned}$$

$$\begin{aligned}\text{Resistance of hatch} &= R_{si} + R + R_a \\ &= 0.104 + 0.178 + 0.090 \\ &= 0.372 \text{ m}^2\text{K/W}\end{aligned}$$

$$\text{Proportional area resistance of hatch} = 0.372 \times 10\% = 0.037 \text{ m}^2\text{K/W}$$

$$\text{Resistance of ceiling} = 5.051 \text{ m}^2\text{K/W (see previous page)}$$

$$\text{Proportional area resistance of ceiling} = 5.051 \times 90\% = 4.546 \text{ m}^2\text{K/W}$$

$$\text{Resistance of pitched component} = 0.286 \text{ m}^2\text{K/W (see previous page)}$$

$$U = \frac{1}{0.286 + 0.037 + 4.546} = \frac{1}{4.869} = 0.205 \text{ W/m}^2\text{K}$$

An area weighted higher U-value than the 0.187 W/m<sup>2</sup>K calculated on the previous page for a fully insulated ceiling.

NB. Proprietary loft hatches are manufactured to incorporate a substantial layer of insulating material.

Standard Assessment Procedure ~ the Approved Document to Part L of the Building Regulations emphasises the importance of quantifying the energy costs of running homes. For this purpose it uses the Government's Standard Assessment Procedure (SAP). SAP has a numerical scale of 1 to 100, although it can exceed 100 if a dwelling is a net energy exporter. It takes into account the effectiveness of a building's fabric relative to insulation and standard of construction. It also appraises the energy efficiency of fuel consuming installations such as ventilation, hot water, heating and lighting. Incidentals like solar gain also feature in the calculations.

As part of the Building Regulations approval procedure, energy rating (SAP) calculations are submitted to the local building control authority. SAP ratings are also required to provide prospective home purchasers or tenants with an indication of the expected fuel costs for hot water and heating. This information is documented and included with the property conveyance. The SAP calculation involves combining data from tables, work sheets and formulae. Guidance is found in Approved Document L, or by application of certified SAP computer software programs.

SAP rating average for all homes is about 50. A modernised 1930s house is about 70, that built to 1995 energy standards about 80 and a 2002 house about 90. Current quality construction standards should rate dwellings close to 100.

Ref. Standard Assessment Procedure for Energy Rating of Dwellings. The Stationery Office.

Air Permeability ~ airtightness in the construction of dwellings is an important quality control objective. Compliance is achieved by attention to detail at construction interfaces, e.g. by silicone sealing built-in joists to blockwork inner leafs and door and window frames to masonry surrounds; draft proofing sashes, doors and loft hatches. Guidance for compliance is provided in Limiting thermal bridging and air leakage: Robust construction details for dwellings and similar buildings, published by The Stationery Office. Dwellings failing to comply with these measures are penalised in SAP calculations. Alternatively, a certificate must be obtained to show pre-completion testing satisfying air permeability of less than  $10 \text{ m}^3/\text{h}$  per  $\text{m}^2$  envelope area at 50 Pascals (Pa or  $\text{N}/\text{m}^2$ ) pressure.

## Thermal Insulation, Elements of Construction (1)

Dwellings in England and Wales ~ the worst acceptable, or the limiting heat energy loss through the enclosing fabric as an area weighted average U-value:

Element of construction	Area weighted average U-value (W/m <sup>2</sup> K)
External wall	0.30
Roof	0.20
Floor	0.25
Party wall	0.20
Windows, roof windows, glazed rooflights and pedestrian doors	2.00 (adjusted for slope)*

Note: Air permeability through the external envelope, not to exceed 10 m<sup>3</sup>/hour per m<sup>2</sup> at 50 Pascals (Pa) pressure.

Area weighted average U-value ~ for an element of construction this depends on the individual U-values of the components and the area they occupy within that element. Some examples with higher thermal transmittance than the adjacent construction to include the part of an external wall containing a meter cupboard and the part of a roof structure containing a loft hatch and/or a rooflight. Also, a window or door U-value is measured with the combined performance of the principal unit and its frame.

Objective U-values ~

Notwithstanding the limiting thermal transmittance values stated above, an objective target for U-values could be better than:

Element of construction	Area weighted average U-value (W/m <sup>2</sup> K)
External wall	0.18
Roof	0.13
Floor	0.13
Party wall	0.00
Windows, roof windows, glazed rooflights and glazed doors	1.40 (adjusted for slope)*
Doors opaque	1.00
Doors semi-glazed	1.20

NB. Air permeability objective not greater than 5 m<sup>3</sup>/hour per m<sup>2</sup> at 50 Pa.

\* See next page.

Typical party wall U-values:

Construction type	U-value (W/m <sup>2</sup> K)
Solid	0.00
Cavity, unfilled without edge sealing	0.50
Cavity, unfilled with edge sealing	0.20
Cavity, filled with edge sealing	0.00

U-values for windows and rooflights ~ these are shown for the unit mounted in a vertical position. Where a window is inclined to the vertical, U-values should be modified relative to the angle of installation. The following table is a guide:

Inclination to the horizontal	U-value (W/m <sup>2</sup> K) increase	
	Double glazed	Triple glazed
< 20°	0.50	0.30
20° - 40°	0.40	0.20
40° - 60°	0.30	0.20
60° - 70°	0.20	0.10
>70°	0.00	0.00

E.g. A triple glazed rooflight with an area weighted average U-value of 1.50 W/m<sup>2</sup>K in a 45° pitched roof.

Revised U-value = 1.50 + 0.20 = 1.70 W/m<sup>2</sup>K.

Total window area and other measures for glazing provision and energy rating are considered on the next page.

References and further reading:

BRE Digest 443: Conventions for U-value calculations.

Building Regulations, Approved Documents:

L1A: Conservation of fuel and power in new dwellings.

L1B: Conservation of fuel and power in existing dwellings.

Domestic Building Services Compliance Guide – NBS for DCLG.

## Thermal Insulation, Elements of Construction (3)

Windows, doors, rooflights and roof windows:

- New dwellings ~ a maximum area is not critical to Approved Document guidance to Building Regulation compliance, except that openable parts should not exceed one quarter of the total floor area. The contribution that window and door openings make to the overall energy efficiency of a dwelling, with particular regard to their U-values is included in SAP calculations. A measure of compliance can be achieved using the BFRC window energy rating and efficiency design guide shown on page 566.
- Existing dwellings ~ extensions and alterations. Approved Document guidance to Building Regulation compliance includes a reasonable provision to limit the total area to the equivalent of 25% of an extension floor area. The BFRC window energy rating of new installations is at least band C, i.e. higher than minus 20 (see page 566) or a U-value of not greater than  $1.6 \text{ W/m}^2\text{K}$  (area weighted combining glazing and frame). Doors to have an area weighted U-value of not greater than  $1.8 \text{ W/m}^2\text{K}$ .

Ref. BFRC ~ British Fenestration Registration Council.

Energy source:

A gas or oil fired central heating boiler with a SEDBUK efficiency rating of 90% (band rating A) is standard installation for new dwellings. There are transitional and exceptional circumstances that may permit lower band rated boilers. Where this occurs, the construction of the building envelope should compensate with very low U-values. An energy recovery system or an alternative/renewable energy system may also be considered as a trade-off. Acceptable standards for solid fuel boilers are provided to HETAS certification (see page 565).

SEDBUK band ratings ~ these are defined in the UK Government's publication, Standard Assessment Procedure for Energy Rating of Dwellings (SAP)

Note: SEDBUK band A = >90% efficiency

.. B = 86-90%	..
.. C = 82-86%	..
.. D = 78-82%	..
.. E = 74-82%	..
.. F = 70-74%	..
.. G = <70%	..

Ref. SEDBUK ~ Seasonal Efficiency of a Domestic Boiler in the UK.

New-build dwellings, limiting or worst acceptable and (objective target) heat energy loss values ~

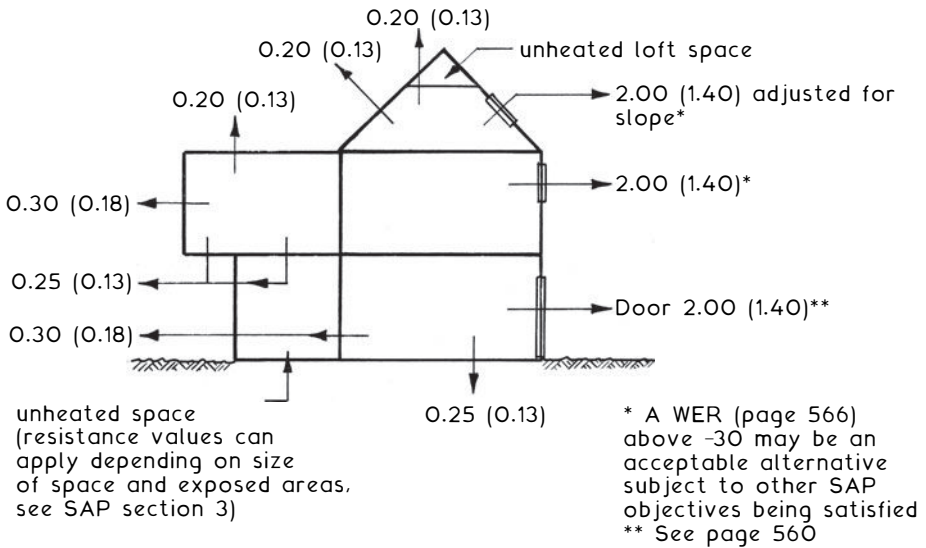

Extensions or alterations to existing dwellings, reasonable/ acceptable heat energy loss objectives ~

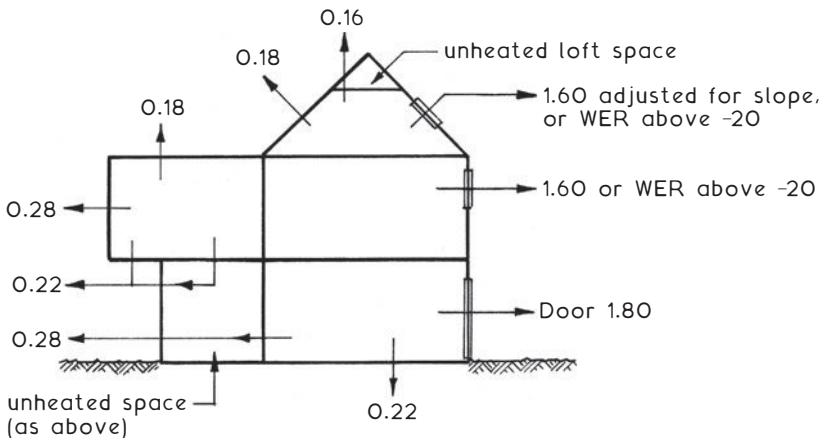

NB. Figures indicate the thermal transmittance coefficient through the fabric of construction. Otherwise known as the U-value, expressed in units of watts per square metre for every one degree Kelvin temperature difference ( $W/m^2K$ ).



## Thermal Insulation – Area Weighted Average

There are many situations in the enclosing envelope of a building where the U-value of the principal construction is interrupted by necessary change. In these instances, U-values are averaged over the material components. Some examples include meter cupboard/cavity wall (illustrated), door/door frame, loft hatch/ceiling and rooflight/roof structure.

Formula ~

$$\text{Area weighted average} = \frac{(U_1 \times A_1) + (U_2 \times A_2) + (U_3 \times A_3), \text{ etc.}}{A_1 + A_2 + A_3, \text{ etc.}}$$

E.g. A 12.00m<sup>2</sup> cavity wall containing gas and electricity meter cupboards, each 0.410m wide x 0.610m high. Thermal transmittance factors 0.25 W/m<sup>2</sup>K and 0.45 W/m<sup>2</sup>K respectively.

Meter cupboard area = 0.41m x 0.61m x 2 = 0.50m<sup>2</sup>

Effective wall area = 12.00 m<sup>2</sup> less 0.50 m<sup>2</sup> = 11.50m<sup>2</sup>

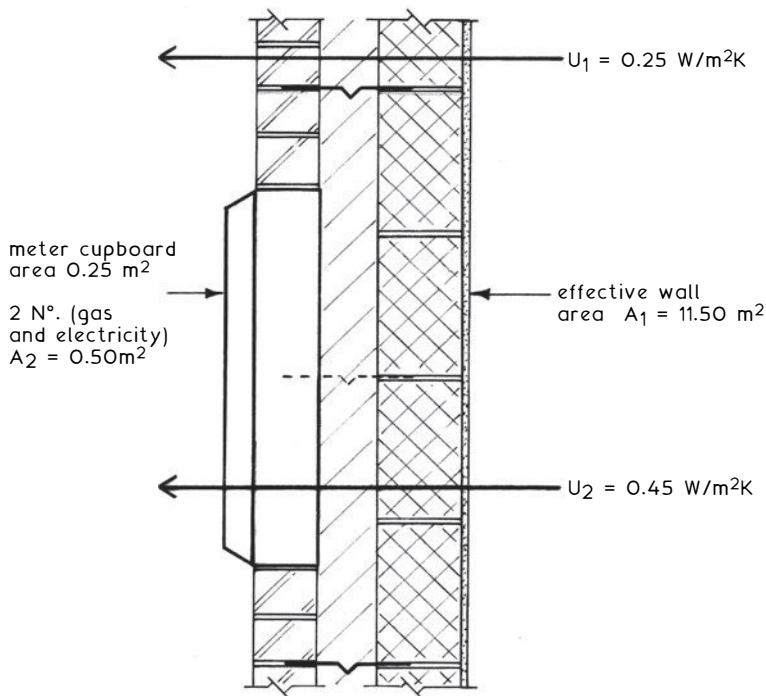

Area weighted U-value ~

$$\frac{(0.25 \times 11.50) + (0.45 \times 0.50)}{11.50 + 0.50} = \frac{2.875 + 0.225}{12.00} = 0.258 \text{ W/m}^2\text{K}$$

NB. See also page 558.

Further quality procedures (structure):

- Provision of insulation to be continuous. Gaps are unacceptable and if allowed to occur will invalidate the insulation value by thermal bridging.
- Junctions at elements of construction (wall/floor, wall/roof) to receive particular attention with regard to continuity of insulation.
- Openings in walls for windows and doors to be adequately treated with insulating cavity closers.

Further quality procedures (energy consumption):

- Hot water and heating systems to be fully commissioned on completion and controls set with regard for comfort, health and economical use of fuel.
- As part of the commissioning process for new wet heating system installations, they should be filled and drained (flushed out) and on refilling, the water should be blended with an anti-corrosion additive diluted to the manufacturer's instructions. This additive also functions as a pump lubricant, an anti-freeze and protection against scaling.
- A certificate confirming heating system commissioning and water treatment should be provided for the new installation user. This document to be accompanied by component manufacturer's operating and maintenance instructions.

Note: Commissioning of heating installations and the issue of certificates is by a qualified 'competent person' as recognised by the appropriate body: CAPITA GROUP, OFTEC or HETAS.

CAPITA GROUP ~ 'Gas Safe Register' of installers (has replaced CORGI).

OFTEC ~ Oil Firing Technical Association for the Petroleum Industry.

HETAS ~ Solid Fuel Heating Equipment Testing and Approval Scheme.

Further quality procedures (existing dwellings) ~

Where an existing dwelling is subject to alterations/extensions and improvements such as refurbishment, it is expected that reasonable provision be made to enhance the thermal properties of the external envelope of the existing structure.

## Thermal Insulation, Window Energy Rating

European Window Energy Rating Scheme (EWERS) ~ an alternative to U-values for measuring the thermal efficiency of windows. U-values form part of the assessment, in addition to factors for solar heat gain and air leakage. In the UK, testing and labelling of window manufacturers' products is promoted by the British Fenestration Rating Council (BFRC). The scheme uses a computer to simulate energy movement over a year through a standard window of 1.480 × 1.230 m containing a central mullion and opening sash to one side.

Data is expressed on a scale from A-G in units of kWh/m<sup>2</sup>/year.

- A > zero
- B -10 to 0
- C -20 to -10
- D -30 to -20
- E -50 to -30
- F -70 to -50
- G < -70

By formula, rating = (218.6 × g value) - 68.5 (U-value × L-value)  
 where: g value = factor measuring effectiveness of solar heat block expressed between 0 and 1. For comparison:

- 0.48 (no curtains)
- 0.43 (curtains open)
- 0.17 (curtains closed)



U-value = weighted average transmittance coefficient  
 L-value = air leakage factor

From the label shown opposite:

$$\begin{aligned} \text{Rating} &= (218.6 \times 0.5) \\ &- 68.5 (1.8 + 0.10) \\ &= 109.3 - 130.15 \\ &= -20.85 \text{ i.e. } -21 \end{aligned}$$

Typical format of a window energy rating label ~

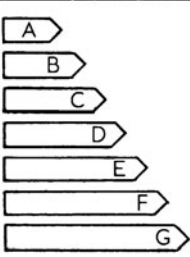
ABC Joinery Ltd.  
 Window ref. XYZ 123

	
Energy index	-21
Climate zone	UK
Thermal trans. (U-value)	1.8 W/m <sup>2</sup> K
Solar factor (g-value)	0.50
Air leakage (L-value)	0.10m <sup>3</sup> /h/m <sup>2</sup> at 50 Pa

Carbon Index ~ the Standard Assessment Procedure (SAP) for energy rating dwellings includes a facility to calculate annual emission of carbon dioxide (CO<sub>2</sub>). This is measured in kilogrammes and can be related to floor area using the following established calculation method for determining a carbon factor (CF) and carbon index (CI):

$$CF = CO_2 \div (\text{total floor area} + 45)$$

$$CI = 17.7 - (9 \log. CF) \quad \text{Note: log.} = \text{logarithm to the base 10.}$$

E.g. A dwelling of floor area 125 m<sup>2</sup> with CO<sub>2</sub> emissions of 2000 kg/yr.

$$CF = 2000 \div (125 + 45) = 11.76$$

$$CI = 17.7 - (9 \log. 11.76) = 8.06$$

The carbon index ranges from zero to 10. Objective values for new dwellings should be at least 9.

DER and TER ~ A.D. L refers to the Dwelling Carbon Emissions Rate (DER) as another means for assessing carbon discharge. The DER is compared by calculation to a Target Carbon Emissions Rate (TER) based on data for type of lighting, floor area, building shape and fuel category. The DER is derived by appraising the potential CO<sub>2</sub> emission relative to the consumption of fuel in hot water, heating, lighting, cooling (if fitted), fans and pumps.

$$DER \leq TER \text{ (units of kg/m}^2 \text{ floor area/year)}$$

Note: DER applies to dwellings. A similar Building Carbon Emissions Rate (BER) is used to assess CO<sub>2</sub> emissions for other building types.

TREE ~ Target Fabric Energy Efficiency is a supplementary performance standard, introduced to A.D. L from 2014 for new buildings. The objective of TREE is to reduce carbon emissions by 6% for dwellings and 9% for non-domestic buildings compared with 2010 requirements. Calculations incorporate factors for U-values, thermal bridging, air permeability, thermal mass, lighting and solar gains. TREE is measured in CO<sub>2</sub> emissions of kWh/m<sup>2</sup>/yr.

Fuel type	CO <sub>2</sub> (kg per kWh) conversion factor
Gas	0.206
Electricity	0.527
Fuel oil	0.215

## Thermal Insulation, UK Carbon Emissions Data

- Basis for improvement ~ total annual CO<sub>2</sub> emissions from building are around 150 million tonnes (MtC).
- CO<sub>2</sub> represents about 85% of all greenhouse gases produced by burning fossil fuels (methane 6%, nitrous oxide 5%, industrial trace gases the remainder).
- 25 million homes produce about 15% (74 MtC) of carbon emissions, representing a significant target for improvement (non-domestic buildings about 17%, 79 MtC).
- The table below shows the main sources of CO<sub>2</sub> emissions in MtC.

Source	1990	1995	2000	2005	2010	2012*
Residential/domestic	79	81	87	84	87	74
Business/non-domestic	113	107	107	97	79	79
Energy supply	241	210	203	216	195	192
Transport	120	120	125	129	119	116
Other	39	36	31	27	18	18
<b>Total</b>	<b>592</b>	<b>554</b>	<b>553</b>	<b>553</b>	<b>498</b>	<b>479</b>

Note: CO<sub>2</sub> emissions have declined significantly by about 19% since 1990, corresponding to about 3% less consumption of fuel energy. These figures are affected by higher energy efficiency of new buildings, climate/temperature change, improved efficiency of power generation and lower usage of carbon intensive coal. Allowing for these variables, in real terms there has been about a 6% reduction in energy use.

\* Provisional figures.

Ref. DECC National statistics.

The energy efficiency of new homes is about 70% higher than those built in 1990. However, many older homes have been improved to include some of the following provisions:

Application	Potential reduction, CO <sub>2</sub> per annum (kg)
Loft insulation	1000
Double glazing	700
Draft proofing (doors, windows, floors)	300
Wall cavity insulation	750
Condensing boiler	875
Insulated hot water storage cylinder	160
Energy saving light bulb	45 (each)

## Thermal Insulation, Dwelling Roof Space

Thermal Insulation ~ this is required within the roof of all dwellings in the UK. It is necessary to create a comfortable internal environment, to reduce the risk of condensation and to economise in fuel consumption costs.

To satisfy these objectives, insulation may be placed between and over the ceiling joists as shown below to produce a *cold roof void*. Alternatively, the insulation can be located above the rafters as shown on page 509. Insulation above the rafters creates a *warm roof void* and space within the roof structure that may be useful for habitable accommodation.

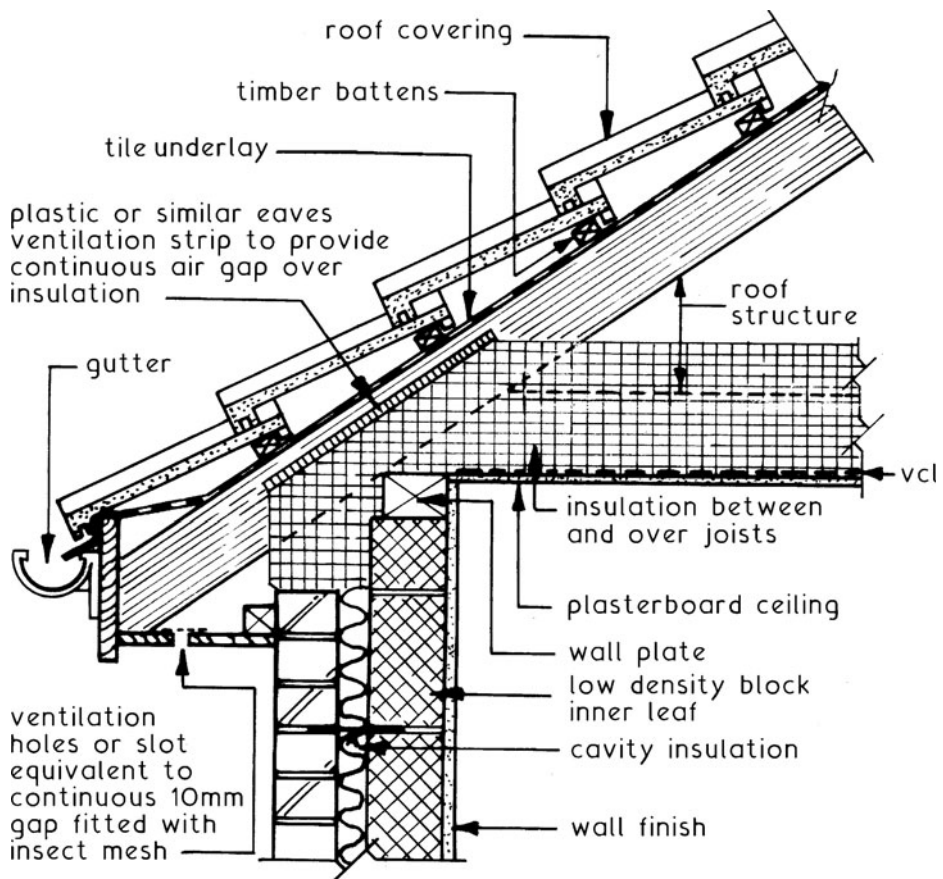

NB. All pipework in roof space should be insulated to prevent frost attack. The sides and top of cold water storage cisterns should be insulated to prevent freezing.

# Thermal Insulation – Pitched Roofs

## Application of Insulation with Typical U-values ~

### Cold roof

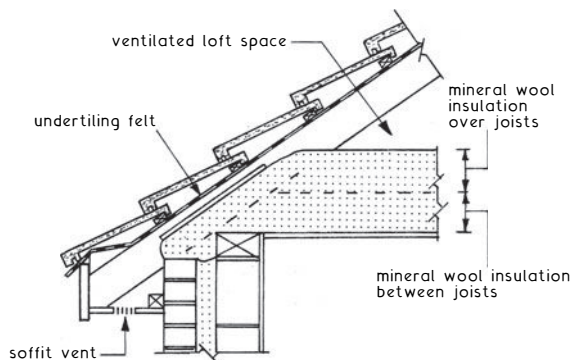

Insulation (mm) between/over joists		U-value W/m <sup>2</sup> K
100	80	0.22
100	100	0.20
100	150	0.16
100	200	0.13
100	250	0.11
100	300	0.10

Note: 200, 250 and 300 mm over joist insulation in two layers.

### Warm roof

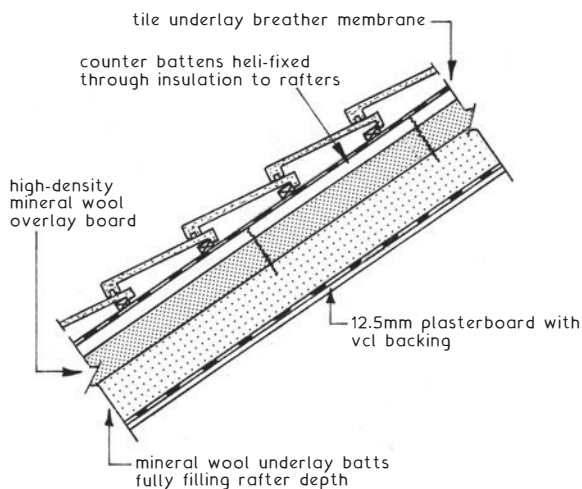

Insulation (mm) underlay/overlay		U-value W/m <sup>2</sup> K
100	50	0.25
100	80	0.21
100	100	0.19
150	50	0.20
150	80	0.17
100	100	0.16

NB. Underlay insulation in between and fully filling the rafter depth. Overlay insulation board under counter battens secured to the top of rafters with helical skewers.

# Thermal Insulation – Flat Roofs (Warm)

Various Applications with Typical Thermal Transmittance Values ~

## Timber

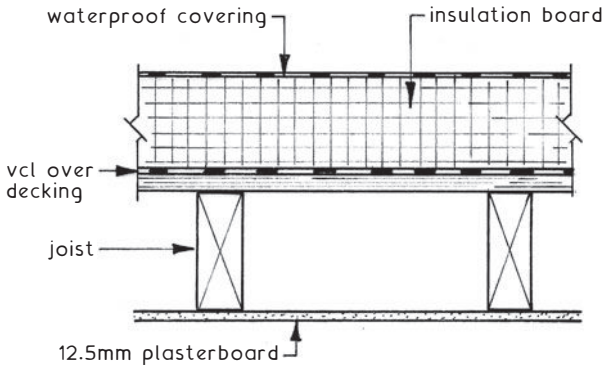

Insulation thickness (mm)	U-value W/m <sup>2</sup> K
130	0.25
165	0.22
190	0.18
220	0.16
270	0.13

## Concrete

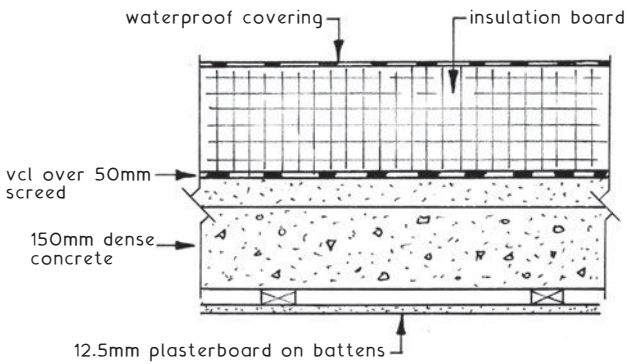

Insulation thickness (mm)	U-value W/m <sup>2</sup> K
130	0.25
165	0.22
190	0.18
220	0.16
270	0.13

## Troughed or profiled steel decking

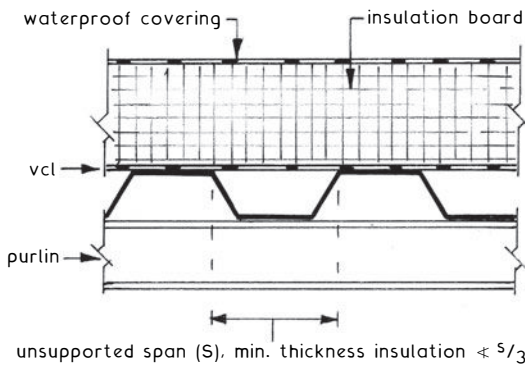

Insulation thickness (mm)	U-value W/m <sup>2</sup> K
145	0.25
165	0.22
210	0.18
230	0.16
280	0.13

NB. Insulation of mineral wool roofing board, with a thermal conductivity ( $\lambda$ ) of 0.038 W/mK.



## Thermal Insulation – External Walls

Thermal Insulation to Walls ~ the minimum performance standards for exposed walls set out in Approved Document L to meet the requirements of Part L of the Building Regulations can be achieved in several ways (see pages 560 and 563). The usual methods require careful specification, detail and construction of the wall fabric, insulating material(s) and/or applied finishes.

Typical examples of existing construction that would require upgrading to satisfy contemporary UK standards ~

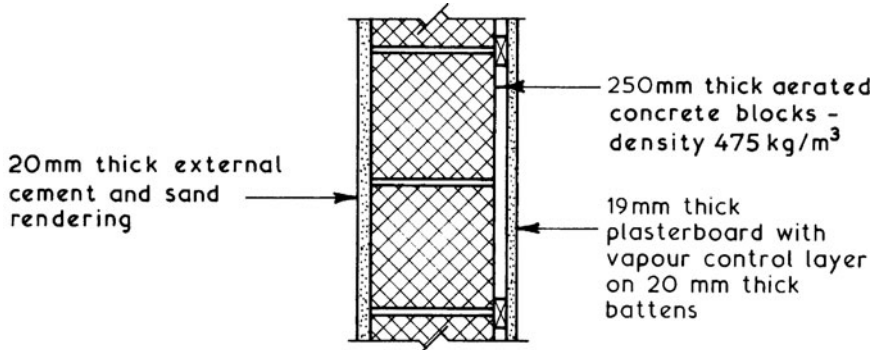

SOLID BLOCK WALL ( $U = 0.45 \text{ W/m}^2\text{K}$ )

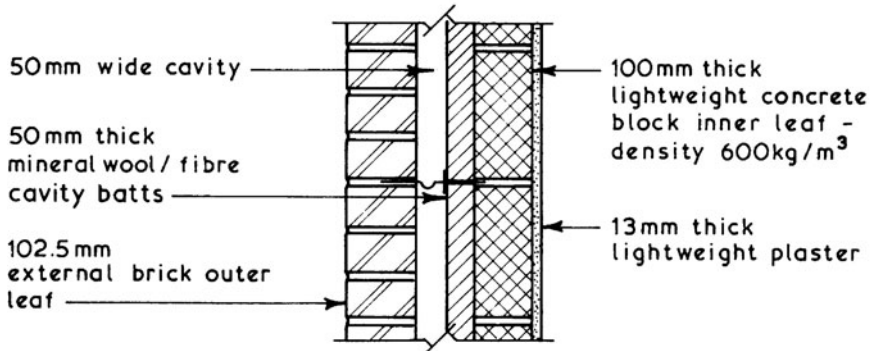

CAVITY WALL WITH CAVITY INSULATING BATTS ( $U = 0.39 \text{ W/m}^2\text{K}$ )

Semi-exposed

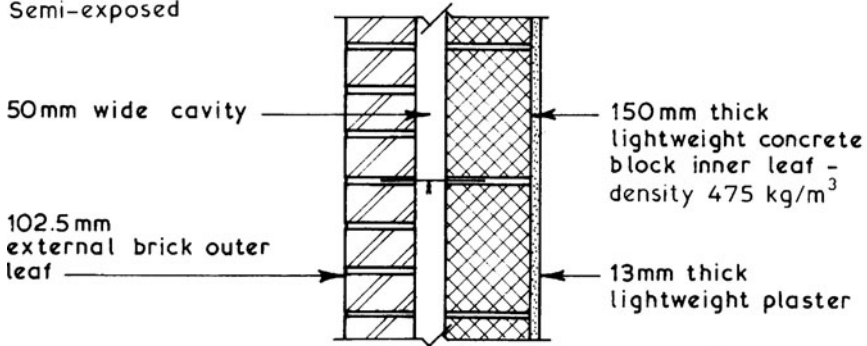

TRADITIONAL CAVITY WALL ( $U = 0.58 \text{ W/m}^2\text{K}$ )

## Thermal Insulation – External Walls

Typical examples of contemporary construction practice that achieve a thermal transmittance or U-value below 0.30 W/m<sup>2</sup>K ~

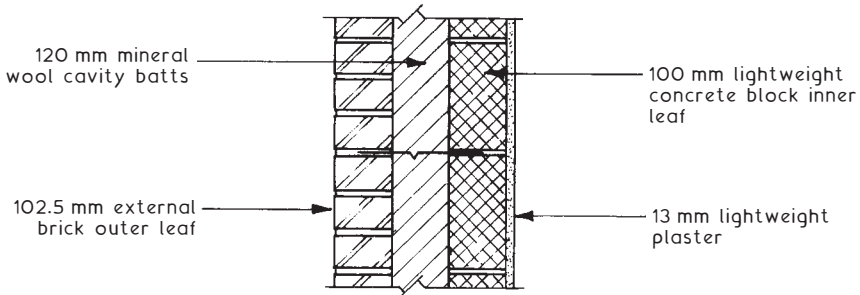

FULL FILL CAVITY WALL, Block density 750 kg/m<sup>3</sup> U = 0.25 W/m<sup>2</sup>K  
 Block density 600 kg/m<sup>3</sup> U = 0.24 W/m<sup>2</sup>K  
 Block density 475 kg/m<sup>3</sup> U = 0.23 W/m<sup>2</sup>K

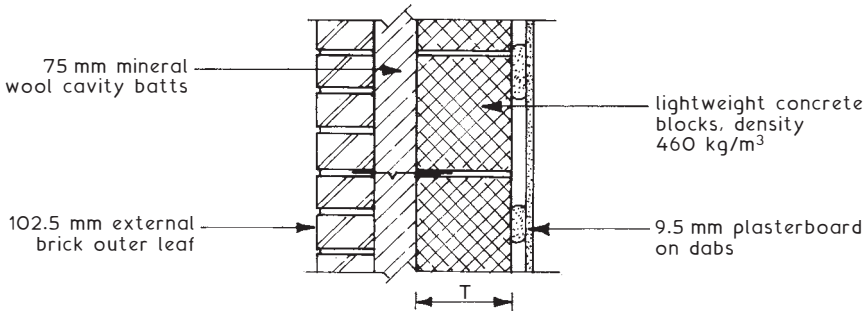

FULL FILL CAVITY WALL, T = 125 mm U = 0.28 W/m<sup>2</sup>K  
 T = 150 mm U = 0.26 W/m<sup>2</sup>K  
 T = 200 mm U = 0.24 W/m<sup>2</sup>K

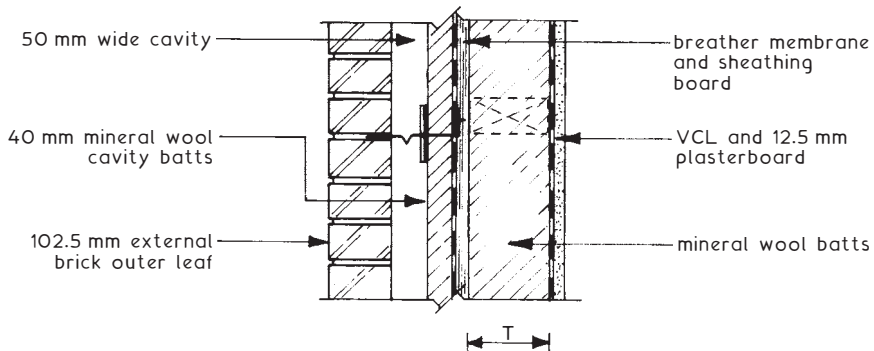

TIMBER FRAME PART CAVITY FILL, T = 100 mm U = 0.26 W/m<sup>2</sup>K  
 T = 120 mm U = 0.24 W/m<sup>2</sup>K  
 T = 140 mm U = 0.21 W/m<sup>2</sup>K

NB. Mineral wool insulating batts have a typical thermal conductivity ( $\lambda$ ) value of 0.038 W/mK.

# Thermal Insulation – External Solid Walls (Improvements)

Improvements to various forms of existing construction with typical thermal transmittance U-values ( $W/m^2K$ ) ~

## Masonry with external insulation

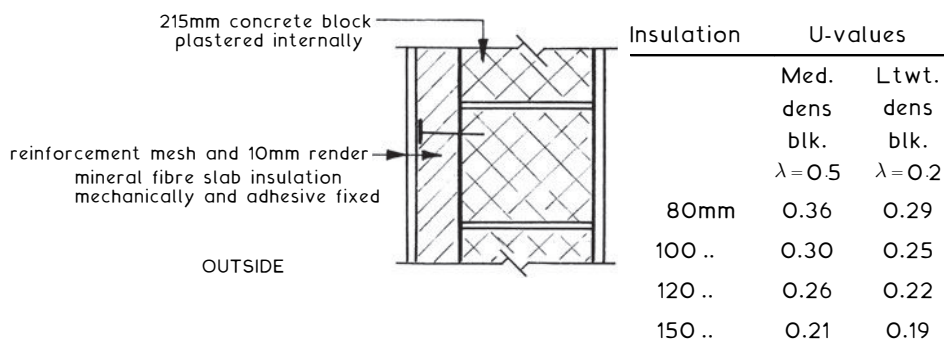
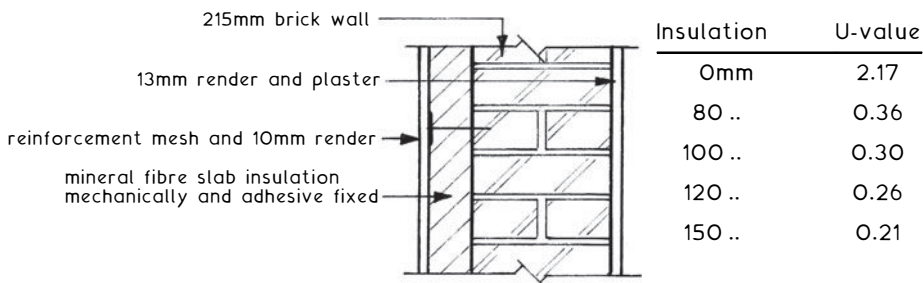

## Masonry with internal insulation

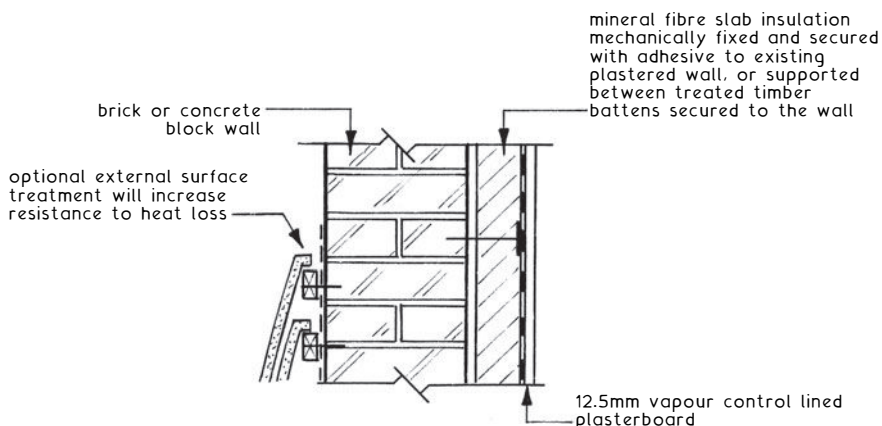

Insulation thickness and U-values as shown for external insulation.

NB. Expanded polystyrene board (EPS) is an alternative insulation material that will provide similar insulation values.

## Thermal Insulation – External Cavity Walls (Improvements – 1)

Cavity filling may be by:

- injected urea-formaldehyde (UF) foam, or
- blown in granulated fibres of mineral wool or perlite.

UF foam ~ a resin and a hardener mixed in solution. Placement into the wall cavity is from the ground upward, by compressed air injection through 12mm holes. After placement the foam hardens. An alternative material is an adhesive polyurethane (PUR) foam. This has an added benefit of bonding the two leaves of masonry, a remedial treatment where wall ties have corroded.

Granulated materials ~ a dry system, pressure injected from ground level upward through 20mm holes.

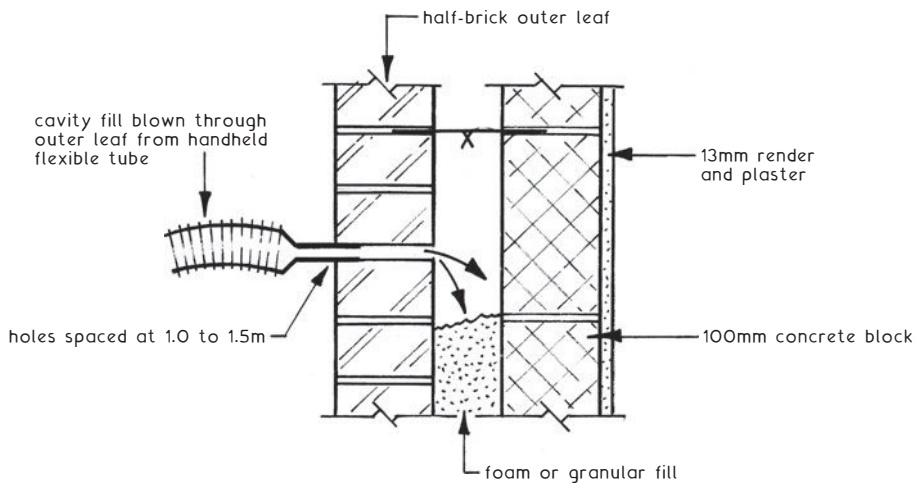

Typical thermal transmittance U-values ( $W/m^2K$ ) ~

Cavity (mm)	Med. dens. block $\lambda=0.5$	L.twt. dens. block $\lambda=0.2$
50	0.54	0.47
75	0.40	0.36
100	0.32	0.29
125	0.27	0.25

Refs.: BS 5617: Specification for urea-formaldehyde foam systems suitable for thermal insulation of cavity walls with masonry or concrete inner and outer leaves.

BS 5618: Code of practice for thermal insulation of cavity walls (with masonry or concrete inner and outer leaves) by filling with urea-formaldehyde foam systems.

Approved Document D – Toxic substances, D1: Cavity insulation.

# Thermal Insulation – External Cavity Walls (Improvements – 2)

Surface treatment may be:

- External if space and access permits, or
- Internal with some loss of room volume, and possibly disturbance to existing surface attachments, e.g. shelves, radiators, electrical sockets and light fittings.

## External

6mm thin coat polymer render (see Note 1)

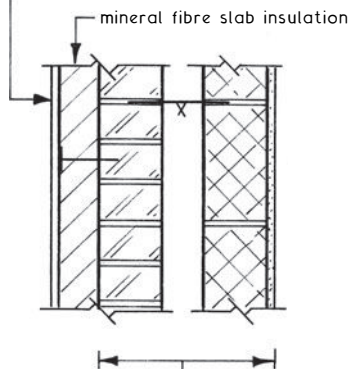

half brick and 100mm concrete block wall with 50mm cavity, rendered and plastered internally

### Typical U-values

Ins. (mm)	Med. dens. blk.	Low dens. blk.
	$\lambda = 0.5$	$\lambda = 0.3$
50	0.51	0.48
75	0.38	0.36
100	0.30	0.29

## Internal

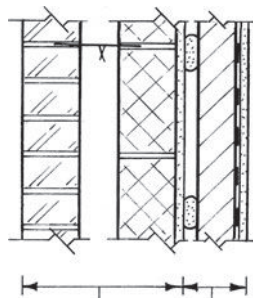

half brick and 100mm concrete block wall with 50mm cavity, rendered and plastered internally

thermal wallboard or mineral fibre slab insulation with vapour control lined plasterboard, fixed to existing wall with multi-purpose adhesive dabs (see Note 2)

### Typical U-values

Ins. (mm)	Med. dens. blk.	Low dens. blk.
	$\lambda = 0.5$	$\lambda = 0.3$
50	0.44	0.42
75	0.34	0.33
100	0.28	0.27

## Notes:

1. A modified alternative to conventional cement and sand render with a polymer, silicone or acrylic additive. Vapour permeable with good weatherproofing qualities.
2. Vapour control layer is an impervious lining of polythene or metal foil placed to the warm side of insulation. Prevents warm moisture from the interior of a house condensing on the cold parts of construction.

## Thermal Insulation – Solid Wall Improvements (RSC)

RSC ~ rainscreen cladding to existing solid masonry walls.

Upgrading existing structures by overcladding has the following benefits:

- \* Enhanced appearance.
- \* Protection to the substructural wall.
- \* Weather exclusion.
- \* Improved thermal insulation.
- \* Improved sound insulation.
- \* No loss or disruption to habitable internal space.

Solid masonry one brick walls typical of many pre-1950s houses have a U-value of about  $2.20 \text{ W/m}^2\text{K}$  (see page 549). Surface insulation and overcladding can considerably reduce this figure to less than  $0.50 \text{ W/m}^2\text{K}$

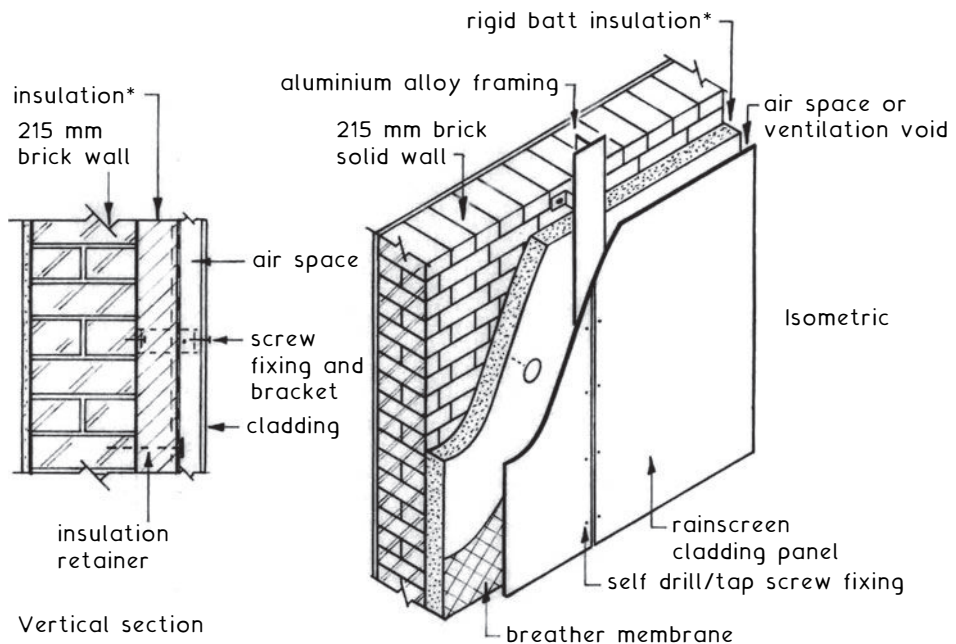

\*Typically expanded polystyrene (EPS), polyurethane (PUR) or glass/mineral wool.

Additional details are shown on pages 705 to 707.

## Thermal Insulation – Cavity Wall Improvements (RSC)

RSC ~ rainscreen cladding to existing and new build cavity walls.

The benefits for solid walls listed on the preceding page apply equally to existing and new cavity wall construction.

Cavity masonry walls for housing have varied materially over a period exceeding 100 years. Some comprise a brick outer and inner leaf, others brick outer leaf and concrete block inner leaf. The composition of concrete blocks has varied considerably over time. Aggregates have included breeze, pumice and wood shavings to name just a few examples. Most brick and block cavity walls have a U-value of around  $1.50 \text{ W/m}^2\text{K}$ . Overcladding and insulation can reduce this figure to less than  $0.4 \text{ W/m}^2\text{K}$ .

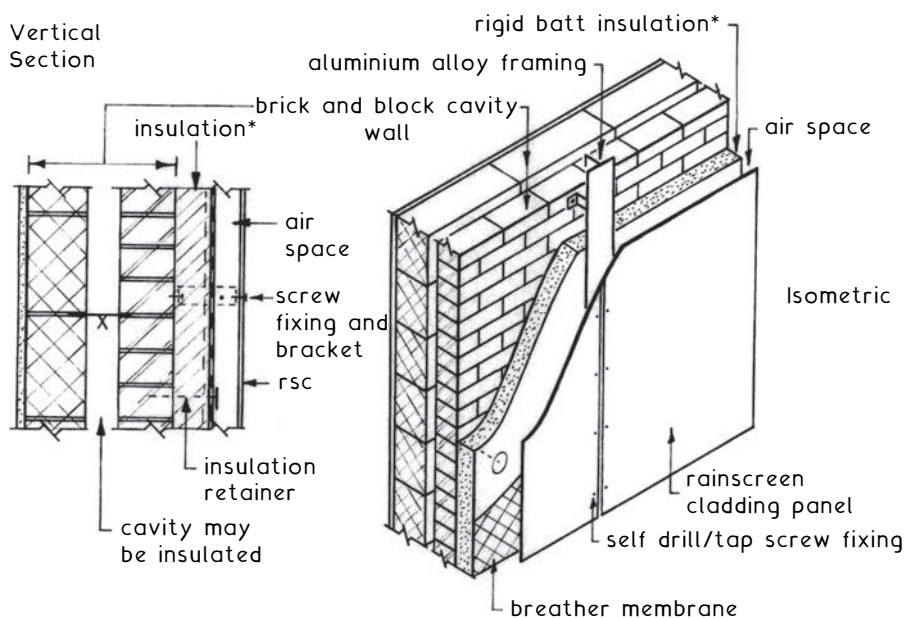

See page 552 for insulation types and comparable conductivity values.

\*See previous page

The U-value ( $W/m^2K$ ) varies with floor shape and size. This is represented as the ratio of perimeter (P) to area (A). Page 553 has a worked example using insulation manufacturers' data for the P/A ratio.

Ground-bearing concrete

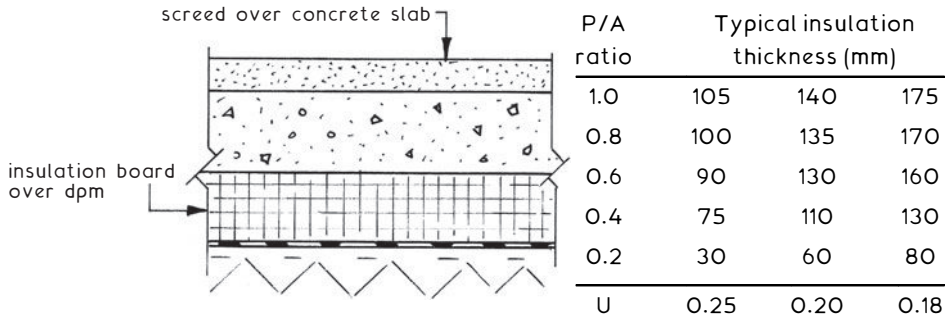

Suspended beam and block

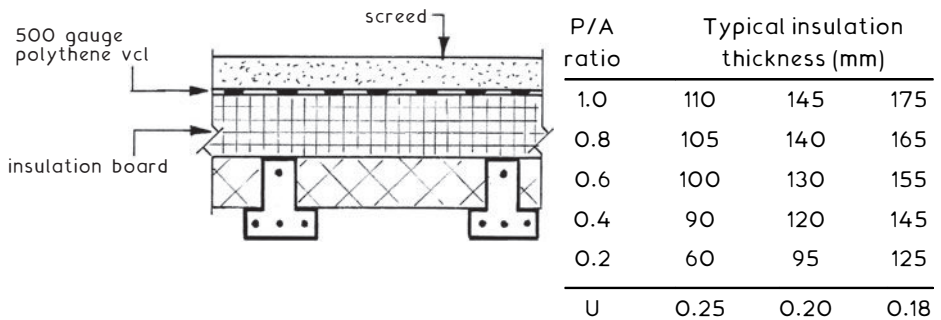

Note: Figures apply to mineral wool insulation board,  $\lambda = 0.038 W/mK$ . Closed cell extruded polystyrene can also be used,  $\lambda = 0.029 W/mK$ .

Suspended timber

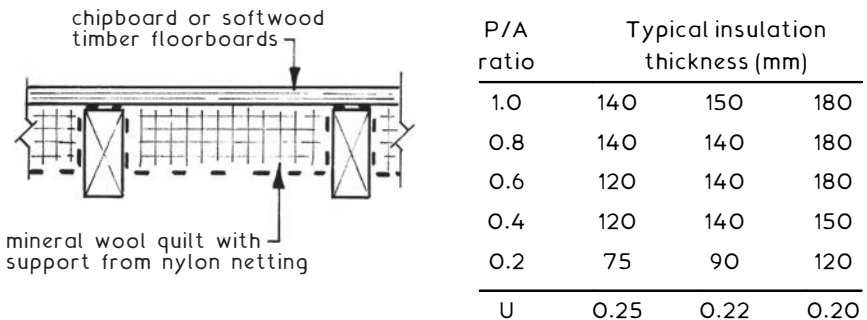



## Thermal Bridging

Thermal or Cold Bridging ~ this is heat loss and possible condensation, occurring mainly around window and door openings and at the junction between ground floor and wall. Other opportunities for thermal bridging occur where uniform construction is interrupted by unspecified components, e.g. occasional use of bricks and/or tile slips to make good gaps in thermal block inner leaf construction.

NB. This practice was quite common, but is no longer acceptable by current legislative standards in the UK.

Prime areas for concern ~

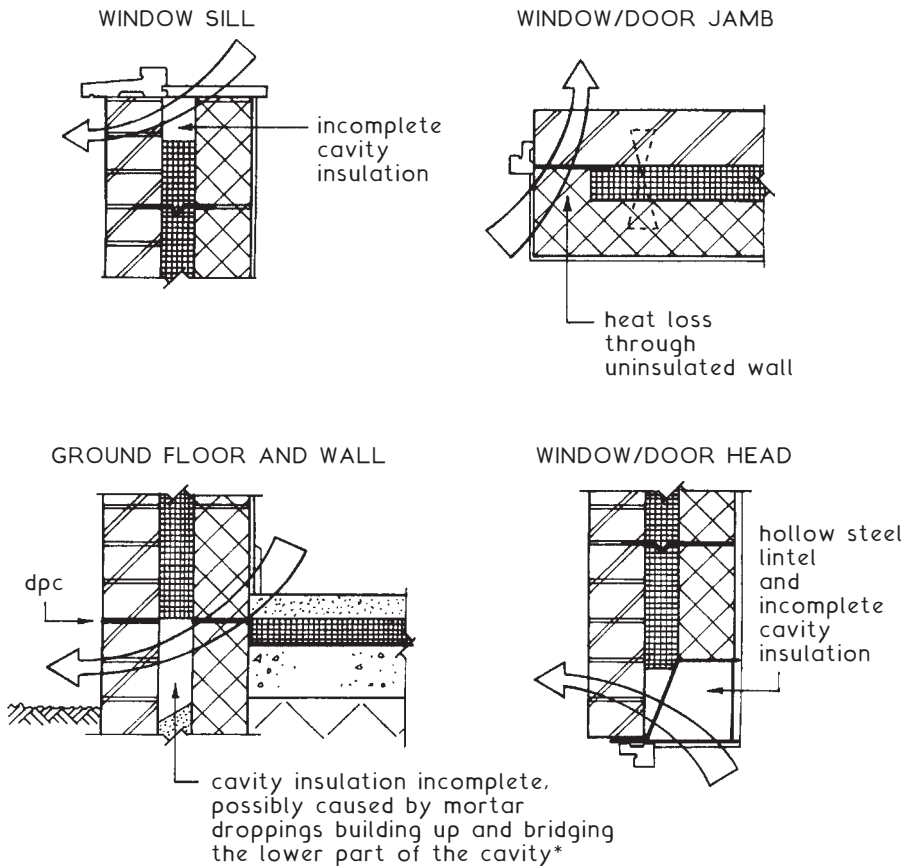

\*Cavity should extend down at least 225mm below the level of the lowest dpc (A.D. C: Section 5).

As shown on the preceding page, continuity of insulated construction in the external envelope is necessary to prevent thermal bridging. Nevertheless, some discontinuity is unavoidable where the pattern of construction has to change. For example, windows and doors have significantly higher U-values than elsewhere. Heat loss and condensation risk in these situations is regulated by limiting areas, effectively providing a trade-off against very low U-values elsewhere.

The following details should be observed around openings and at ground floor ~

WINDOW SILL

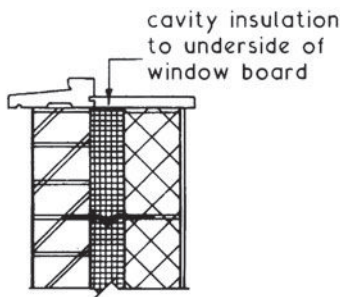

WINDOW/DOOR JAMB

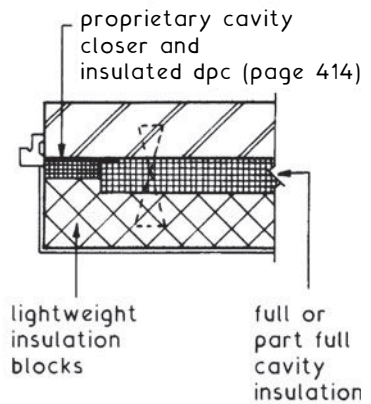

GROUND FLOOR AND WALL

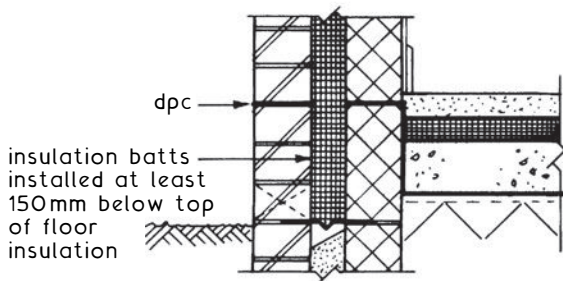

WINDOW/DOOR HEAD

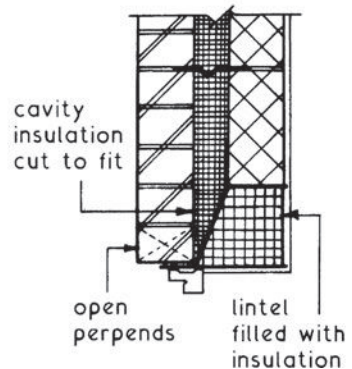

## Thermal Bridging

The possibility of a thermal or cold bridge occurring in a specific location can be appraised by calculation. Alternatively, the calculations can be used to determine how much insulation will be required to prevent a cold bridge. The composite lintel of concrete and steel shown below will serve as an example ~

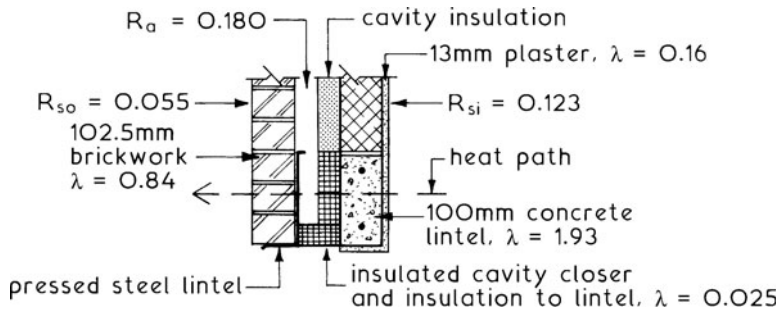

Wall components, less insulation (steel in lintel is insignificant):

102.5mm brickwork outer leaf,	$\lambda = 0.84 \text{ W/mK}$
100mm dense concrete lintel,	$\lambda = 1.93 \dots$
13mm lightweight plaster,	$\lambda = 0.16 \dots$

Resistances of above components:

Brickwork,	$0.1025 \div 0.84 = 0.122 \text{ m}^2\text{K/W}$
Concrete lintel,	$0.100 \div 1.93 = 0.052 \dots$
Lightweight plaster,	$0.013 \div 0.16 = 0.081 \dots$

Resistances of surfaces:

Internal ( $R_{si}$ ) = 0.123 ..
Cavity ( $R_a$ ) = 0.180 ..
External ( $R_{so}$ ) = 0.055 ..
Summary of resistances = 0.613 ..

To achieve a U-value of say  $0.27 \text{ W/m}^2\text{K}$ ,  
total resistance required =  $1 \div 0.27 = 3.703 \text{ m}^2\text{K/W}$

The insulation in the cavity at the lintel position is required to have a resistance of  $3.703 - 0.613 = 3.09 \text{ m}^2\text{K/W}$

Using a urethane insulation with a thermal conductivity ( $\lambda$ ) of  $0.025 \text{ W/mK}$ ,  
 $0.025 \times 3.09 = 0.077 \text{ m}$  or 77 mm minimum thickness.

If the cavity closer has the same thermal conductivity, then:

Summary of resistance =  $0.613 - 0.180 (R_a) = 0.433 \text{ m}^2\text{K/W}$

Total resistance required =  $3.703 \text{ m}^2\text{K/W}$ , therefore the cavity closer is required to have a resistance of:  $3.703 - 0.433 = 3.270 \text{ m}^2\text{K/W}$

Min. cavity closer width =  $0.025 \text{ W/mK} \times 3.270 \text{ m}^2\text{K/W} = 0.082 \text{ m}$  or 82 mm.

In practice, the cavity width and the lintel insulation would exceed 82 mm.

NB. data for resistances and  $\lambda$  values taken from pages 550 to 552.

Air Infiltration ~ heating costs will increase if cold air is allowed to penetrate peripheral gaps and breaks in the continuity of construction. Furthermore, heat energy will escape through structural breaks and the following are prime situations for treatment:

1. Loft hatch
2. Services penetrating the structure
3. Opening components in windows, doors and rooflights
4. Gaps between dry lining and masonry walls

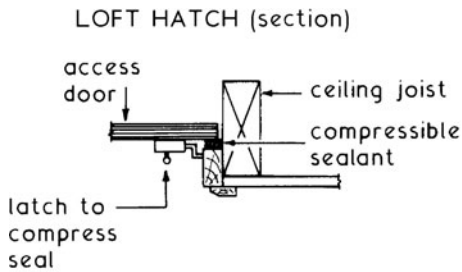

**SERVICES ACCESS (vertical section)**

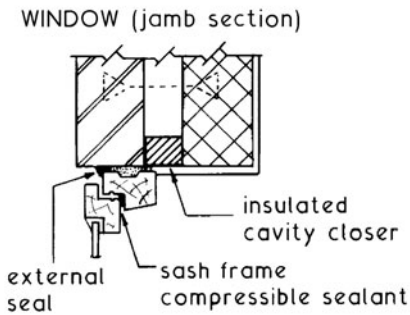
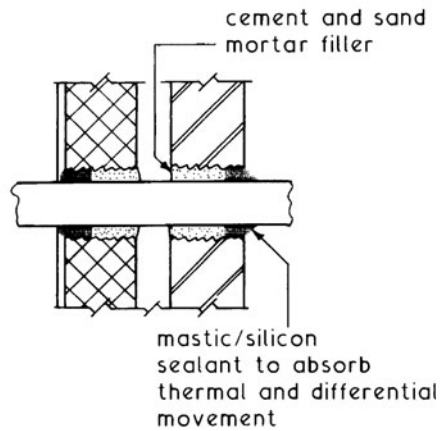

**DRY LINING (Suspended floor and door jamb)**

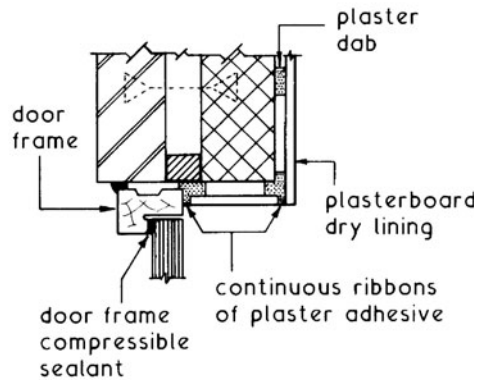
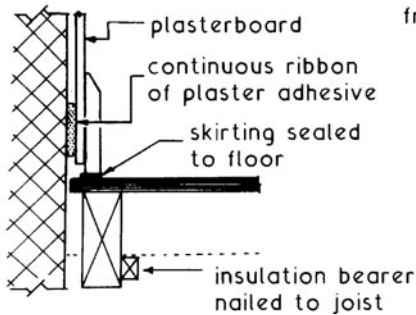

NB. See page 431 for threshold detail.

## Thermal Insulation, Buildings Other Than Dwellings (1)

With new buildings and those subject to alterations, the objective is to optimise the use of fuel and power to minimise emission of carbon dioxide and other burnt fuel gases into the atmosphere. This applies principally to the installation of hot water, heating, lighting, ventilation and air conditioning systems.

Guidance to satisfy the Building Regulations is provided in Approved Document L2, but this is not prescriptive. It sets out a series of objectives relating to achievement of a satisfactory carbon emission standard. Other technical references and approvals are cross referenced in the Approved Document and these provide a significant degree of design flexibility in achieving its objectives.

Energy efficiency assessment in terms of limiting CO<sub>2</sub> emissions for a proposed building is determined by applying a series of procedures modelled on the specification of a building the same size and shape as the proposal. The performance standards are given in the 2013 National Calculation Methodology (NCM) modelling guide published by the DCLG. The proposed or actual building must be seen to have the same as or less carbon emissions by calculation. Improvements can be achieved in many ways, including the following:

- Limit the area or number of rooflights, windows and other openings.
- Improve the U-values of the external envelope. The limiting or worst acceptable are shown on the following page.
- Improve the building airtightness from the poorest acceptable air permeability of 10 m<sup>3</sup> per hour per m<sup>2</sup> of external envelope at 50 Pa.
- Improve the heating system efficiency by installing thermostatic, zone and optimum time controls. Fully insulate pipes, ducting, storage vessels and other energy consuming plant.
- Use high efficacy lighting fittings, automated controls and low voltage equipment.
- Apply heat recovery systems to ventilation and air conditioning systems.
- Install a building energy management system to monitor and regulate heating and air conditioning plant.
- Limit overheating with solar controls and purpose-made glazing.
- Provide continuity of insulation about the external envelope.
- Establish a commissioning and plant maintenance procedure, with a log book to record all repairs, replacements and inspections.

Further guidance: Non-domestic Building Services Compliance Guide. A DCLG (Dept. for Communities and Local Government) publication.

## Thermal Insulation, Buildings Other Than Dwellings (2)

Buildings other than dwellings (England and Wales), worst acceptable or limiting heat energy loss through the enclosing fabric ~

Element of construction	Area weighted average U-value (W/m <sup>2</sup> K)
External wall	0.35
Roof	0.25
Floor	0.25
Windows, pedestrian doors, rooflights, roof windows and curtain walling	2.20
High use entrances and roof vents	3.50
Large vehicle access doors	1.50

Notes:

- For display windows and for building types that may be exempted, see Section 3 in A.D. L2A.
- U-values for inclined windows modified as shown on page 561.
- The worst acceptable thermal transmittance values allow for some design flexibility by permitting a trade-off against other fuel-saving features such as energy recovery systems.
- The U-value standard is set with regard to minimising the risk of condensation.
- Elements of construction will normally be expected to provide much better insulation than the limiting U-values. Objective or target design values could be better than:

External wall	0.23 W/m <sup>2</sup> K
Roof	0.15 ..
Floor	0.20 ..
Windows, etc.	1.50 ..

Building airtightness  $\leq 5\text{m}^3$  per hour per  $\text{m}^2$  at 50 Pa pressure.

Continuity of insulation ~ conformity can be shown in the form of a report produced for the local authority building control department by an accredited surveyor. The report can contain confirmation of:

- \* an approved design specification and construction practice to an acceptable standard, or
- \* a thermographic survey showing continuity of insulation over the external envelope. This is essential where it is impractical to fully inspect the work in progress.

Airtightness ~ tested by using portable fans of a capacity to suit the building volume. Smoke capsules in conjunction with fan pressurisation provide a visual indication of air leakage paths.

## Access for the Disabled – Dwellings

Main features of Approved Document (A.D.) M: Access to and use of buildings, and other associated guidance:

- \* Site entrance or car parking space to building entrance to be firm and level. Building approach width 900 mm min. A gentle slope is acceptable with a gradient up to 1 in 20 and up to 1 in 40 in cross-falls. A slightly steeper ramped access or easy steps should satisfy A.D. Sections 6.14 and 6.15, and 6.16 and 6.17 respectively.
- \* An accessible threshold for wheelchairs is required at the principal entrance – see illustration.
- \* Entrance door – minimum clear opening width of 775 mm.
- \* Corridors, passageways and internal doors of adequate width for wheelchair circulation. Minimum 750 mm – see also table 4 in A.D. Section 7.
- \* Stair minimum clear width of 900 mm, with provision of handrails both sides. Other requirements as A.D. K for private stairs.
- \* Accessible light switches, power, telephone and aerial sockets between 450 and 1200 mm above floor level.
- \* WC provision in the entrance storey or first habitable storey. Door to open outward. Clear wheelchair space of at least 750 mm in front of WC and a preferred dimension of 500 mm either side of the WC as measured from its centre.
- \* Special provisions are required for passenger lifts and stairs in blocks of flats, to enable disabled people to access other storeys. See A.D. Section 9 for details.

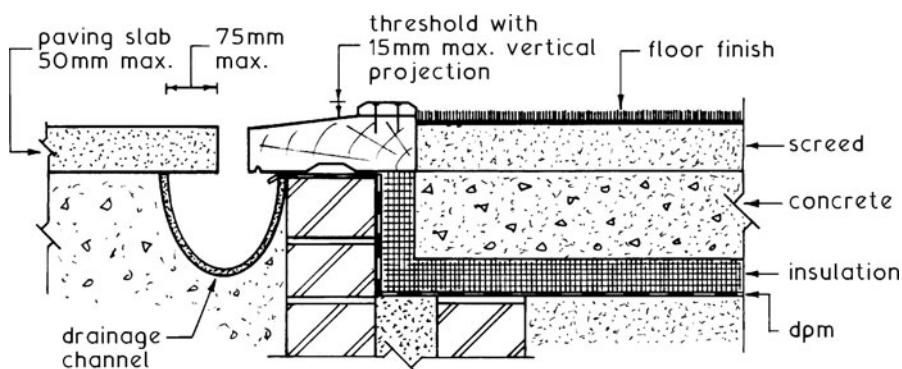

Refs.: Accessible thresholds in new housing – Guidance for house builders and designers. The Stationery Office.

BS 8300: Design of buildings and their approaches to meet the needs of disabled people. Code of practice.

Objective ~ car parking should be provided for visitors, customers and employees requiring access to a building. The main entrance to a building and any other entrances used by employees should be reasonably accessible on foot or by wheelchair from any of the allocated car parking spaces. Parking for the disabled should be prioritised, specifically designated and given larger bay areas to allow people with restricted mobility to access their vehicles unimpeded.

Provisions for designated parking spaces:

- Location to be clearly signed at the car park entrance.
- Specific bays to be clearly identified.
- Surfaces to be firm, durable and slip resistant on level ground with no undulations greater than 5 mm.
- No further distance than 50 m from the main entrance to a building.
- Bay width to be sufficient to allow car doors to fully open for wheelchair space and passenger transfer.
- Dropped kerb access of at least 1.20 m width for wheelchair access.
- Parking ticket machines to be in close proximity, with controls between 0.75 m and 1.20 m above the adjacent ground.

Designated parking bays ~

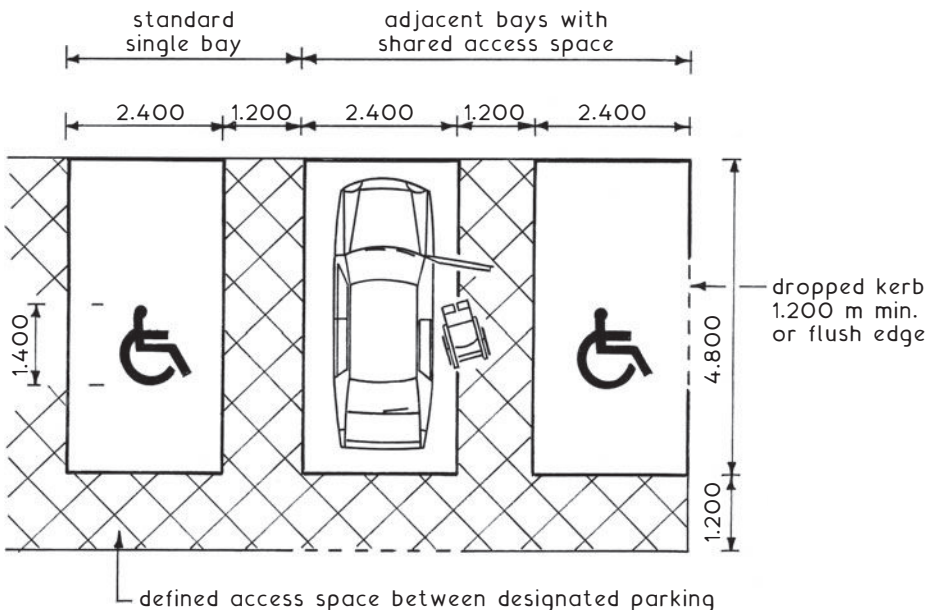



## Access for the Disabled – Buildings Other Than Dwellings

### Main features:

- \* Site entrance, or car parking space to building entrance to be firm and level, i.e. maximum gradient 1 in 20 with a minimum car access zone of 1200 mm. Ramped and easy stepped approaches are also acceptable.
- \* Access to include tactile warnings, i.e. profiled (blistered or ribbed) pavings over a width of at least 1200 mm, for the benefit of people with impaired vision. Dropped kerbs are required to ease wheelchair use.
- \* Special provision for handrails is necessary for those who may have difficulty in negotiating changes in level.
- \* Guarding and warning to be provided where projections or obstructions occur, e.g. tactile paving could be used around window opening areas.
- \* Sufficient space for wheelchair manoeuvrability in entrances.

Minimum entrance width of 800 mm. Unobstructed space of at least 300 mm to the leading (opening) edge of door. Glazed panel in the door to provide visibility from 500 to 1500 mm above floor level. Entrance lobby space should be sufficient for a wheelchair user to clear one door before opening another.

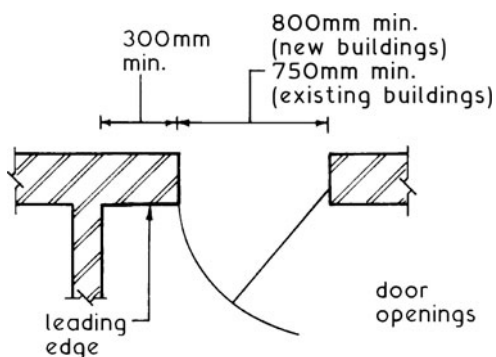

- \* Width of door opening measured as the effective clear dimension at right angles to the wall containing a door, to include the door frame/lining and stop and any other projection.

continued.....

- \* Main access and internal fire doors that self-close should have a maximum operating force of 20 Newtons at the leading edge. If this is not possible, a power operated door opening and closing system is required.
- \* Corridors and passageways, minimum unobstructed width 1200 mm. Internal lobbies as described on the previous page for external lobbies.
- \* Lift dimensions and capacities to suit the building size. Ref. BS EN 81 series: Safety rules for the construction and installation of lifts. Alternative vertical access may be by wheelchair stairlift, see BS EN 81-40 (special lifts and lifting platforms) and BS 6440: Powered vertical lifting platforms having non-enclosed or partially enclosed liftways intended for use by persons with impaired mobility.
- \* Stair minimum width 1200 mm, with step nosings brightly distinguished. Rise maximum 12 risers external, 16 risers internal between landings. Landings to have 1200 mm of clear space from any door swings. Step rise, maximum 170 mm and uniform throughout. Step going, minimum 250 mm (internal), 280 mm (external) and uniform throughout. No open risers. Handrail to each side of the stair.
- \* Number and location of WCs to reflect ease of access for wheelchair users. In no case should a wheelchair user have to travel more than one storey. Provision may be 'unisex' which is generally more suitable, or 'integral' with specific sex conveniences. Particular provision is outlined in Section 5 of the Approved Document.
- \* Section 4 of the Approved Document should be consulted for special provisions in restaurants, bars and hotel bedrooms, and for special provisions for spectator seating in theatres, stadia and conference facilities.

Refs.: Building Regulations, Approved Document M: Access to and use of buildings.

Disability Discrimination Act.

BS 9999: Code of practice for fire safety in the design, management and use of buildings.

BS 8300: Design of buildings and their approaches to meet the needs of disabled people. Code of practice.

*This page intentionally left blank*

## 6 SUPERSTRUCTURE – 2



REINFORCED CONCRETE SLABS  
REINFORCED CONCRETE FRAMED STRUCTURES  
STRUCTURAL CONCRETE, FIRE PROTECTION  
FORMWORK  
PRECAST CONCRETE FRAMES  
PRESTRESSED CONCRETE  
STRUCTURAL STEELWORK ASSEMBLY  
STRUCTURAL STEELWORK CONNECTIONS  
STRUCTURAL FIRE PROTECTION  
PORTAL FRAMES  
COMPOSITE TIMBER BEAMS  
ROOF SHEET COVERINGS  
LONG SPAN ROOFS  
SHELL ROOF CONSTRUCTION  
MEMBRANE ROOFS  
ROOFLIGHTS  
PANEL WALLS, RAINSCREEN CLADDING AND CURTAIN  
WALLING  
CONCRETE CLADDINGS  
CONCRETE SURFACE FINISHES AND DEFECTS

## Simply Supported RC Slabs

Simply Supported Slabs ~ these are slabs which rest on a bearing and for design purposes are not considered to be fixed to the support and are therefore, in theory, free to lift. In practice however they are restrained from unacceptable lifting by their own self-weight plus any loadings.

Concrete Slabs ~ concrete is a material which is strong in compression and weak in tension, and if the member is overloaded its tensile resistance may be exceeded leading to structural failure.

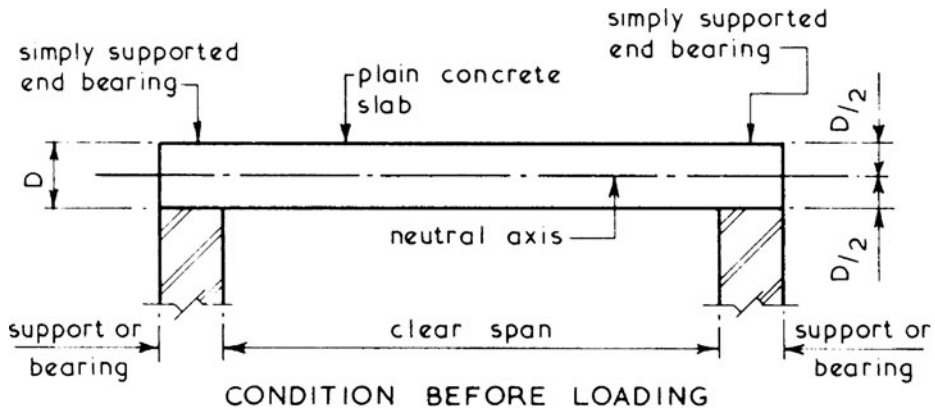

neutral axis length remains unaltered therefore no stress is induced

upper fibres shorten and are therefore in a state of compression

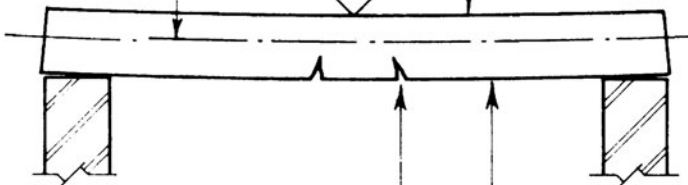
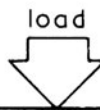

if tensile resistance of the slab is exceeded cracks caused by the parting of the fibres will occur—if this is likely to arise steel reinforcement should be placed in the slab

lower fibres lengthen and are therefore in a state of tension

deflection—maximum allowed  
 $\frac{1}{240}$  span during construction  
 $\frac{1}{360}$  span after completion

Reinforcement ~ generally in the form of steel bars which are used to provide the tensile strength which plain concrete lacks. The number, diameter, spacing, shape and type of bars to be used have to be designed; a basic guide is shown on pages 597 and 598. Reinforcement is placed as near to the outside as practicable, with sufficient cover of concrete over the reinforcement to protect the steel bars from corrosion and to provide a degree of fire resistance. Slabs which are square in plan are considered to be spanning in two directions and therefore main reinforcing bars are used both ways, whereas slabs which are rectangular in plan are considered to span across the shortest distance and main bars are used in this direction only with smaller diameter distribution bars placed at right angles forming a mat or grid.

Typical Details ~

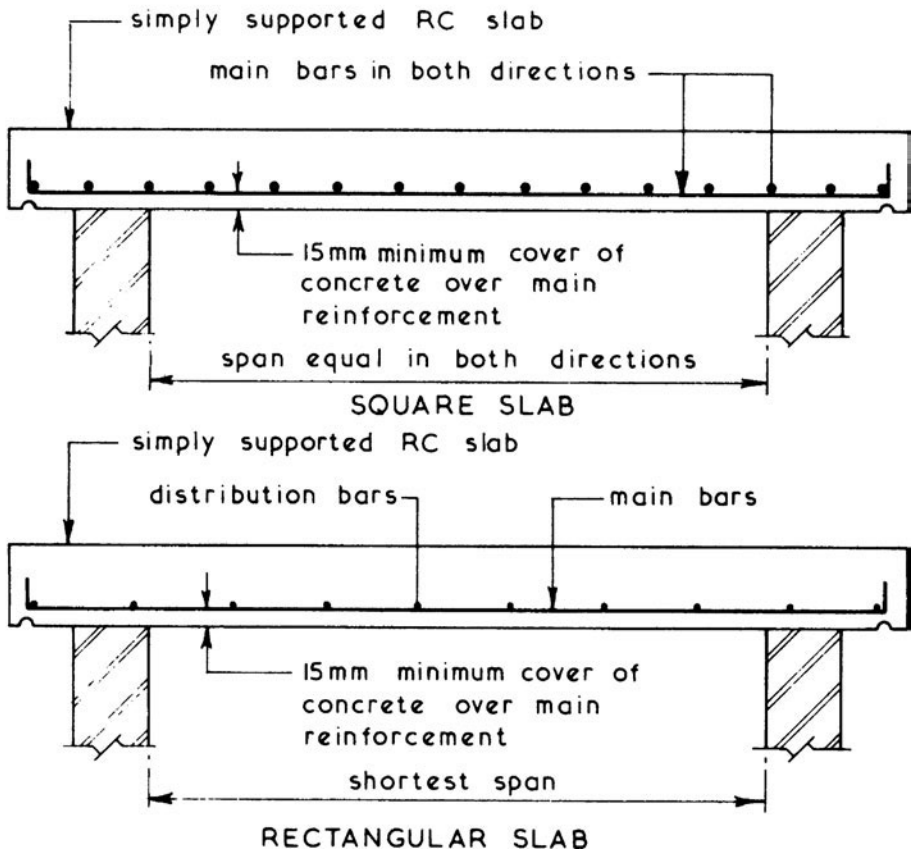

# Simply Supported RC Slabs

Construction ~ whatever method of construction is used the construction sequence will follow the same pattern:

1. Assemble and erect formwork.
2. Prepare and place reinforcement.
3. Pour and compact or vibrate concrete.
4. Strike and remove formwork in stages as curing proceeds.

Typical Example ~

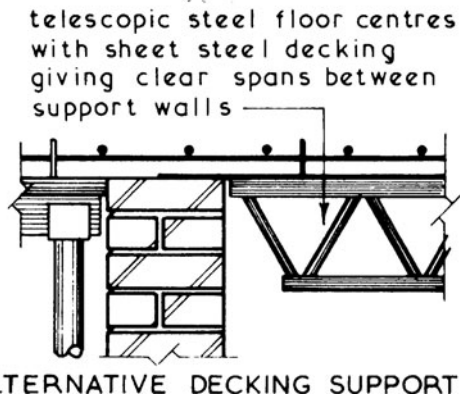
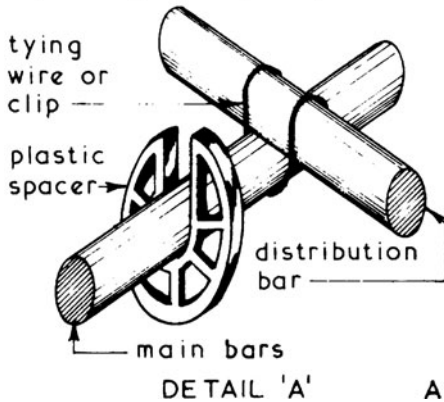
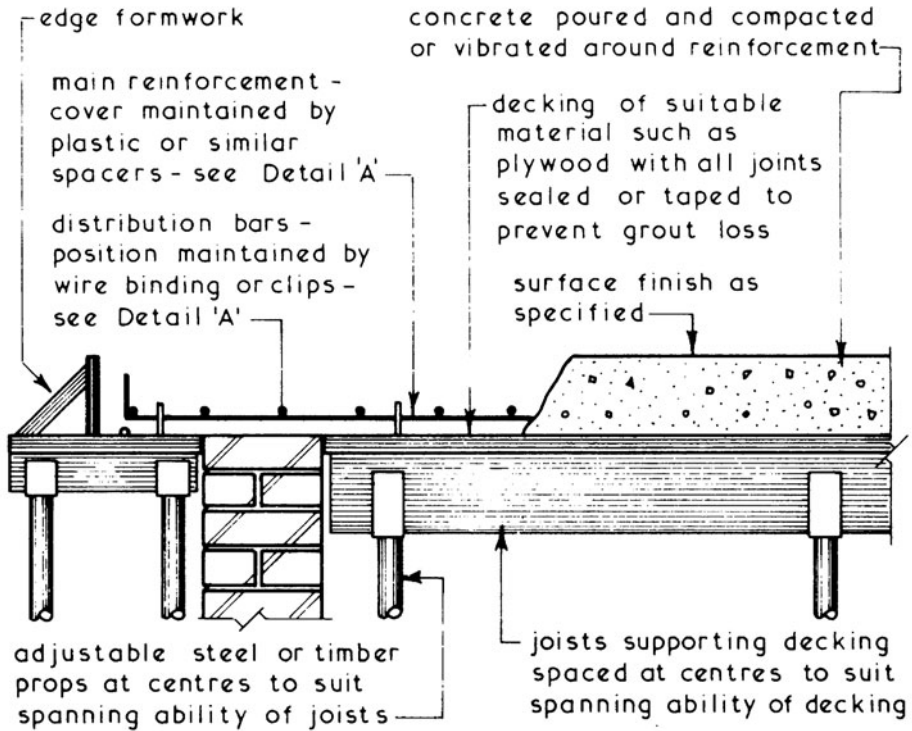

## Metal Section (MetSec) Decking

Profiled galvanised steel decking is a permanent formwork system for construction of composite floor slabs. The steel sheet has surface indentations and deformities to effect a bond with the concrete topping. The concrete will still require reinforcing with steel rods or mesh, even though the metal section will contribute considerably to the tensile strength of the finished slab.

Typical Detail -

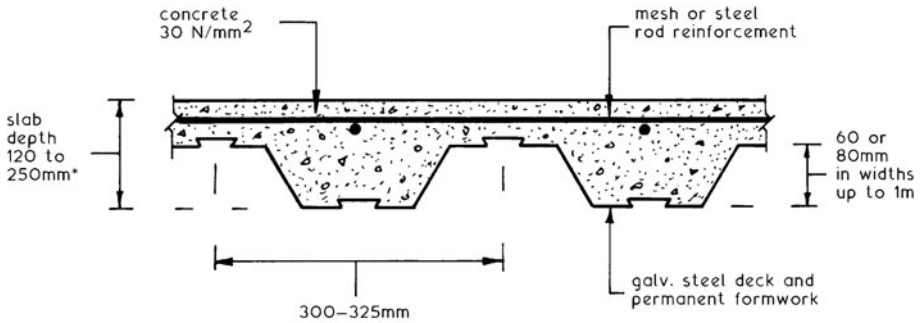

\* For slab depth and span potential, see BS EN1994-1-1: Design of composite steel and concrete structures. General rules and rules for buildings.

Where structural support framing is located at the ends of a section and at intermediate points, studs are through-deck welded to provide resistance to shear -

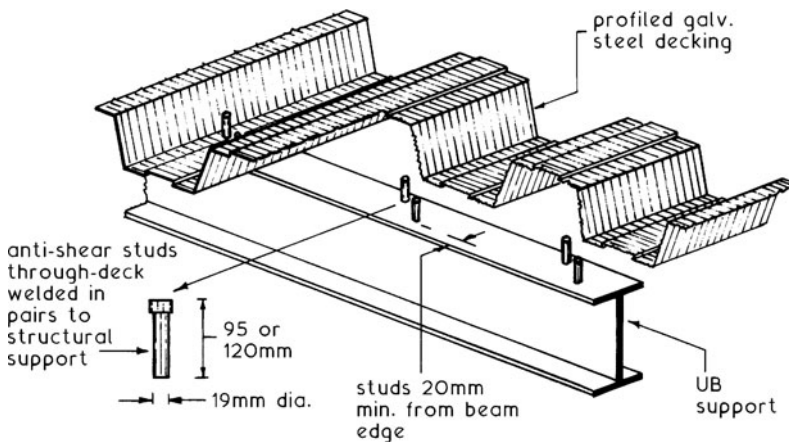

There are considerable savings in concrete volume compared with standard in-situ reinforced concrete floor slabs. This reduction in concrete also reduces structural load on foundations.



# In-situ RC Framed Structures – Beams

Beams ~ these are horizontal load bearing members which are classified as either main beams which transmit floor and secondary beam loads to the columns or secondary beams which transmit floor loads to the main beams.

Concrete being a material which has little tensile strength needs to be reinforced to resist the induced tensile stresses which can be in the form of ordinary tension or diagonal tension (shear). The calculation of the area, diameter, type, position and number of reinforcing bars required is one of the functions of a structural engineer.

Typical RC Beam Details ~

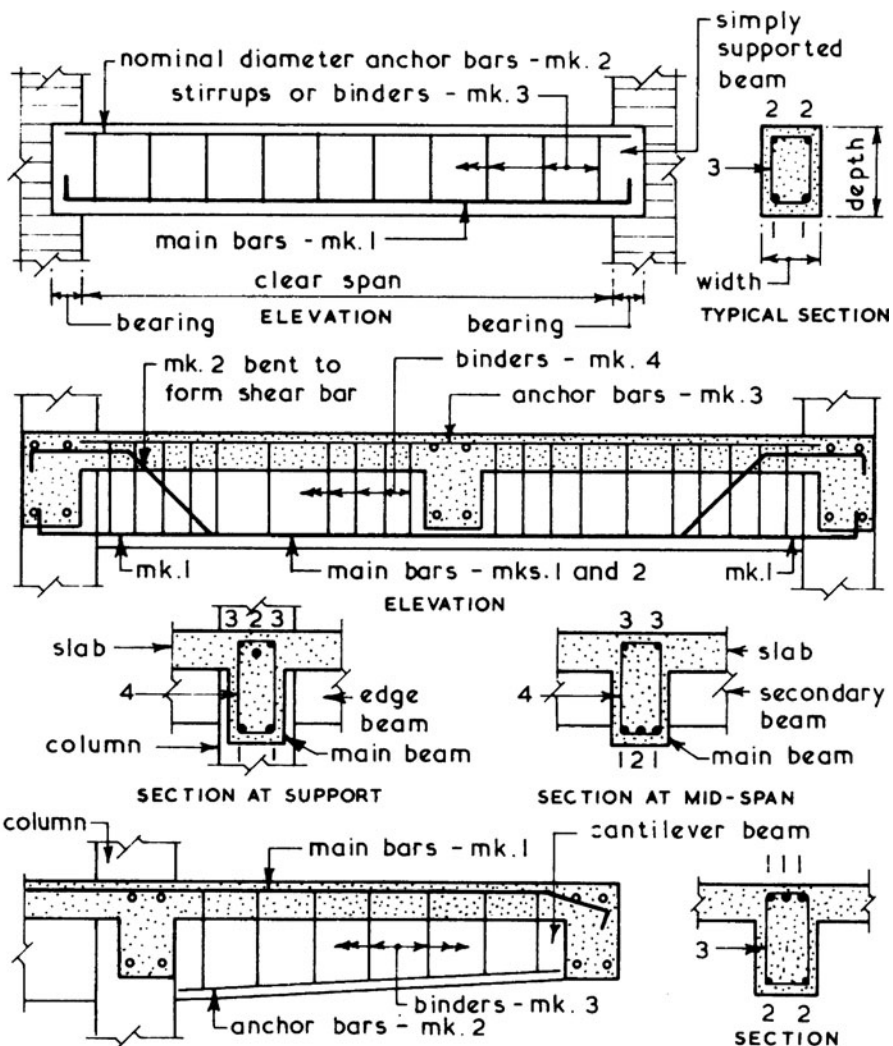

# Simple Reinforced Concrete Beam and Slab Design (1)

Mild Steel Reinforcement – located in areas where tension occurs in a beam or slab. Concrete specification is normally 25 or 30 N/mm<sup>2</sup> in this situation.

## Simple beam or slab

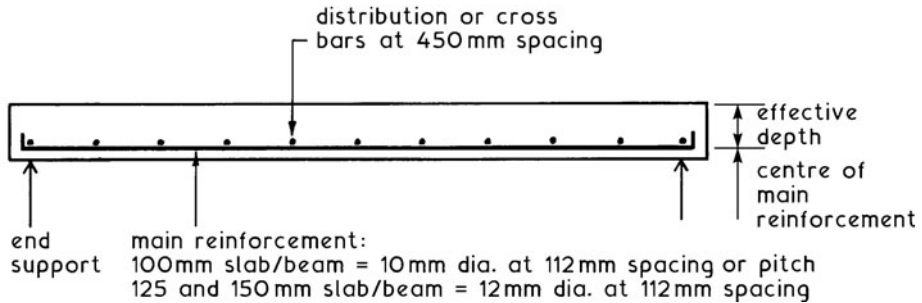

## Continuous beam or slab

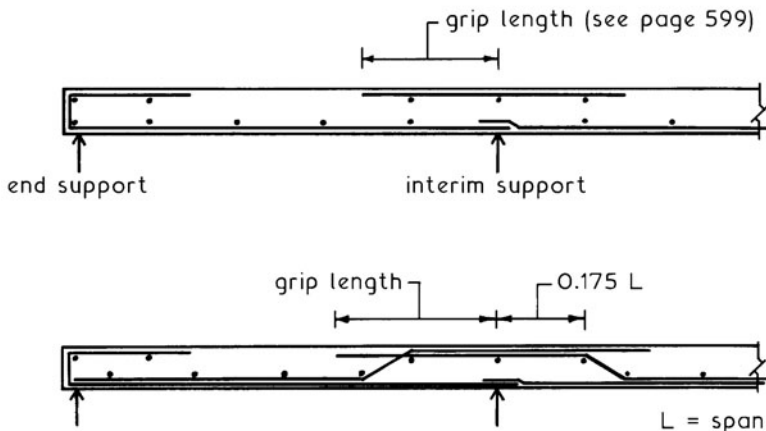

NB. Distribution or cross bars function as lateral reinforcement and supplement the unit's strength in tensile areas. They also provide resistance to cracking in the concrete as the unit contracts during setting and drying.

Pitch of main bars  $\leq 3 \times$  effective depth.

Pitch of distribution bars  $\leq 5 \times$  effective depth.

## Simple Reinforced Concrete Beam and Slab Design (2)

Guidance - simply supported slabs are capable of the following loading relative to their thickness:

Thickness (mm)	Self-weight (kg/m <sup>2</sup> )	Imposed load* (kg/m <sup>2</sup> )	Total load		Span (m)
			(kg/m <sup>2</sup> )	(kN/m <sup>2</sup> )	
100	240	500	740	7.26	2.4
125	300	500	800	7.85	3.0
150	360	500	860	8.44	3.6

NB. As a *rule of thumb*, it is easy to remember that for general use (as above), thickness of slab equates to 1/24 span.

\* Imposed loading varies with application from 1.5 kN/m<sup>2</sup> (153 kg/m<sup>2</sup>) for domestic buildings, to over 10 kN/m<sup>2</sup> (1020 kg/m<sup>2</sup>) for heavy industrial storage areas. 500 kg/m<sup>2</sup> is typical for office filing and storage space. See BS EN 1991-1-1: Actions on structures. General actions. Densities, self-weight, imposed loads for buildings.

For larger spans - thickness can be increased proportionally to the span, e.g. 6 m span will require a 250 mm thickness.

For greater loading - slab thickness is increased proportionally to the square root of the load, e.g. for a total load of 1500 kg/m<sup>2</sup> over a 3m span:

$$\sqrt{\frac{1500}{800}} \times 125 = 171.2 \quad \text{i.e. } 175 \text{ mm}$$

Continuous beams and slabs have several supports, therefore they are stronger than simple beams and slabs. The spans given in the above table may be increased by 20% for interior spans and 10% for end spans.

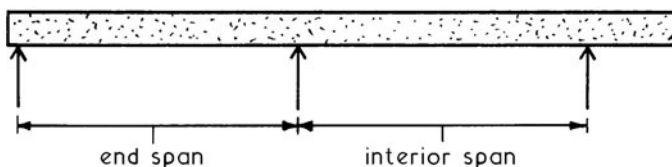

Deflection limit on reinforced concrete beams and slabs is 1/250 span.  
Ref.:

BS EN 1992-1-1: Design of concrete structures. General rules and rules for buildings.

NB. See pages 642 and 643 for deflection formulae.

## Grip Length of Reinforcement

Bond Between Concrete and Steel – permissible stress for the bond between concrete and steel can be taken as one-tenth of the compressive concrete stress, plus  $0.175 \text{ N/mm}^2$ . Given the stresses in concrete and steel, it is possible to calculate sufficient grip length.

E.g. concrete working stress of  $5 \text{ N/mm}^2$   
steel working stress of  $125 \text{ N/mm}^2$   
sectional area of reinf. bar =  $3.142 r^2$  or  $0.7854 d^2$   
tensile strength of bar =  $125 \times 0.7854 d^2$   
circumference of bar =  $3.142 d$   
area of bar in contact =  $3.142 \times d \times L$

Key:  $r$  = radius of steel bar  
 $d$  = diameter of steel bar  
 $L$  = Length of bar in contact

\* Conc. bond stress =  $(0.10 \times 5 \text{ N/mm}^2) + 0.175 = 0.675 \text{ N/mm}^2$

Total bond stress =  $3.142 d \times L \times 0.675 \text{ N/mm}^2$

Thus, developing the tensile strength of the bar:

$$125 \times 0.7854 d^2 = 3.142 d \times L \times 0.675$$

$$98.175 d = 2.120 L$$

$$L = 46 d$$

As a guide to good practice, a margin of  $14 d$  should be added to  $L$ . Therefore the bar bond or grip length in this example is equivalent to  $60$  times the bar diameter.

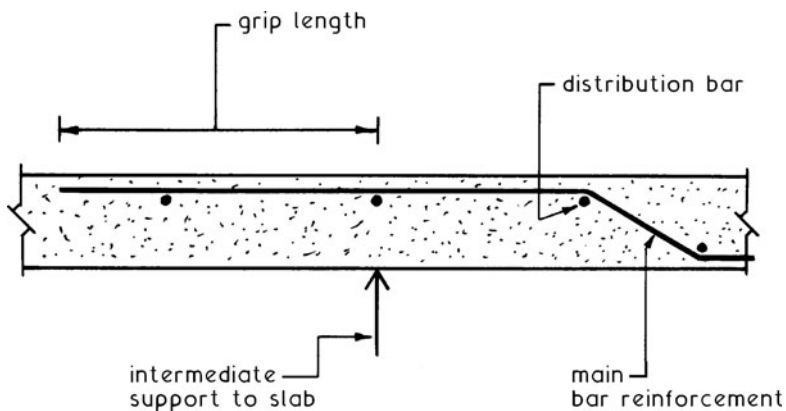

# In-situ RC Framed Structures – Columns

Columns ~ these are the vertical load bearing members of the structural frame which transmits the beam loads down to the foundations. They are usually constructed in storey heights and therefore the reinforcement must be lapped to provide structural continuity.

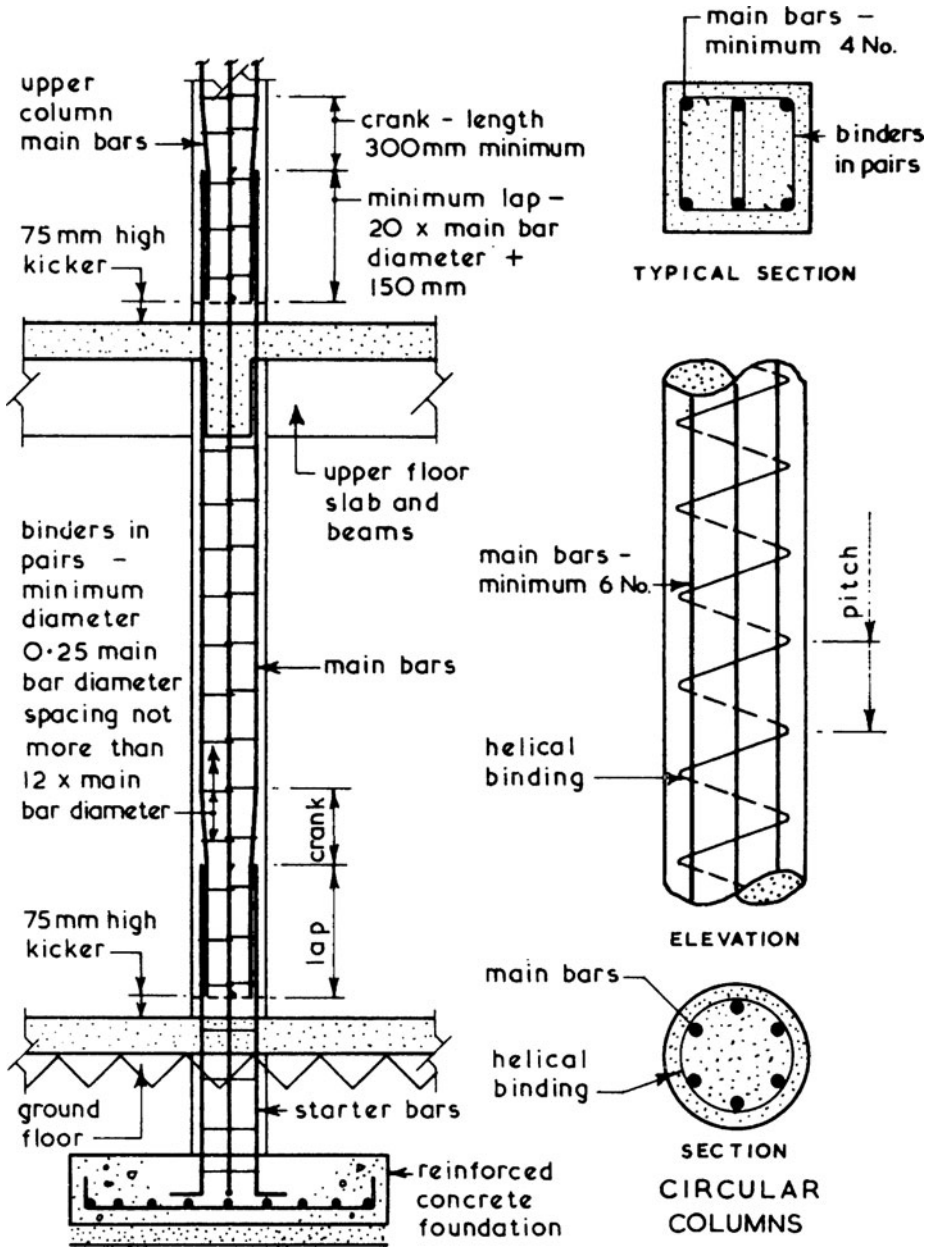

With the exception of where bars are spliced ~

### BEAMS

The distance between any two parallel bars in the horizontal should be not less than the greater of:

- \* 25mm
- \* the bar diameter where they are equal
- \* the diameter of the larger bar if they are unequal
- \* 6mm greater than the largest size of aggregate in the concrete

The distance between successive layers of bars should be not less than the greater of:

- \* 15mm (25mm if bars > 25mm dia.)
- \* the maximum aggregate size

An exception is where the bars transverse each other, e.g. mesh reinforcement.

### COLUMNS

Established design guides allow for reinforcement of between 0.8% and 8% of column gross cross sectional area. A lesser figure of 0.6% may be acceptable. A relatively high percentage of steel may save on concrete volume, but consideration must be given to the practicalities of placing and compacting wet concrete. If the design justifies a large proportion of steel, it may be preferable to consider using a concrete clad rolled steel I section.

Transverse reinforcement ~ otherwise known as binders or links. These have the purpose of retaining the main longitudinal reinforcement during construction and restraining each reinforcing bar against buckling. Diameter, take the greater of:

- \* 6mm
- \*  $0.25 \times$  main longitudinal reinforcement

Spacing or pitch, not more than the lesser of:

- \* least lateral column dimension
- \*  $12 \times$  diameter of smallest longitudinal reinforcement
- \* 300mm

Helical binding ~ normally, spacing or pitch as above, unless the binding has the additional function of restraining the concrete core from lateral expansion, thereby increasing its load carrying potential. This increased load must be allowed for with a pitch:

- \* not greater than 75mm
- \* not greater than  $0.166 \times$  core diameter of the column
- \* not less than 25mm
- \* not less than  $3 \times$  diameter of the binding steel

NB. Core diameter is measured across the area of concrete enclosed within the centre line of the binding.

## Simple Reinforced Concrete Column Design (1)

Typical RC Column Details ~

Steel Reinforced Concrete - a modular ratio represents the amount of load that a square unit of steel can safely transmit relative to that of concrete. A figure of 18 is normal, with some variation depending on materials specification and quality.

e.g.

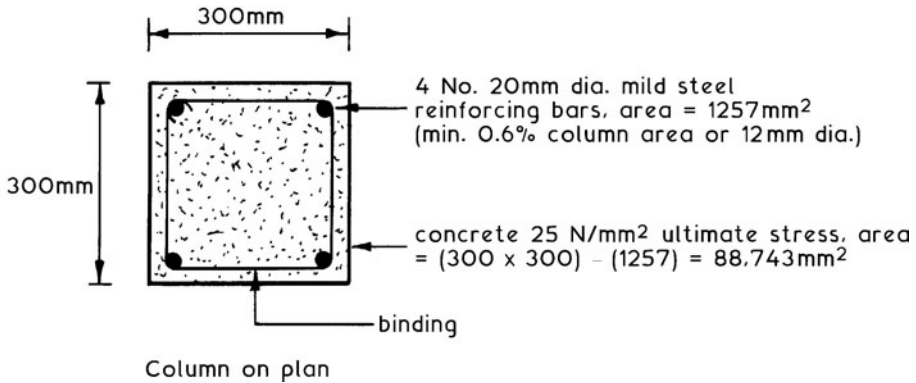

Area of concrete = 88,743 mm<sup>2</sup>

Equivalent area of steel = 18 × 1257 mm<sup>2</sup> = 22626 mm<sup>2</sup>

Equivalent combined area of concrete and steel:

$$\begin{array}{r} 88743 \\ +22626 \\ \hline 111369\text{mm}^2 \end{array}$$

Using concrete with a safe or working stress of 5 N/mm<sup>2</sup>, derived from a factor of safety of 5, i.e.

$$\text{Factory of safety} = \frac{\text{Ultimate stress}}{\text{Working stress}} = \frac{25 \text{ N/mm}^2}{5 \text{ N/mm}^2} = 5 \text{ N/mm}^2$$

5 N/mm<sup>2</sup> × 111369 mm<sup>2</sup> = 556845 Newtons

kg × 9.81 (gravity) = Newtons

Therefore:  $\frac{556845}{9.81} = 56763\text{kg}$  or 56.76 tonnes permissible load

NB. This is the safe load calculation for a reinforced concrete column where the load is axial and bending is minimal or non-existent, due to a very low slenderness ratio (effective length to least lateral dimension). In reality this is unusual and the next example shows how factors for buckling can be incorporated into the calculation.

## Simple Reinforced Concrete Column Design (2)

Buckling or Bending Effect - the previous example assumed total rigidity and made no allowance for column length and attachments such as floor beams.

The working stress unit for concrete may be taken as 0.8 times the maximum working stress of concrete where the effective length of column (see page 645) is less than 15 times its least lateral dimension. Where this exceeds 15, a further factor for buckling can be obtained from the following:

Effective length ÷ Least lateral dimension	Buckling factor
15	1.0
18	0.9
21	0.8
24	0.7
27	0.6
30	0.5
33	0.4
36	0.3
39	0.2
42	0.1
45	0

Using the example from the previous page, with a column effective length of 9 metres and a modular ratio of 18:

$$\text{Effective length} \div \text{Least lateral dimension} = 9000 \div 300 = 30$$

From above table the buckling factor = 0.5

$$\text{Concrete working stress} = 5 \text{ N/mm}^2$$

$$\text{Equivalent combined area of concrete and steel} = 111369 \text{ mm}^2$$

$$\text{Therefore: } 5 \times 0.8 \times 0.5 \times 111369 = 222738 \text{ Newtons}$$

$$\frac{222738}{9.81} = 22705 \text{ kg or } 22.7 \text{ tonnes permissible load}$$



## Identification of Concrete Reinforcement

Bar Coding ~ a convenient method for specifying and coordinating the prefabrication of steel reinforcement in the assembly area. It is also useful on site, for checking deliveries and locating materials relative to project requirements. BS EN ISO 3766 provides guidance for a simplified coding system, such that bars can be manufactured and labelled without ambiguity for easy recognition and application on site.

A typical example is the beam shown on page 596, where the lower longitudinal reinforcement (mk.1) could be coded:

2T20-1-200B or, ①2TØ20-200-B-21

2 = number of bars

T = deformed high yield steel (460 N/mm<sup>2</sup>, 8–40 mm dia.)

20 or, Ø20 = diameter of bar (mm)

1 or ① = bar mark or ref. no.

200 = spacing (mm)

B = located in bottom of member

21 = shape code

Other common notation:

R = plain round mild steel (250 N/mm<sup>2</sup>, 8–16 mm dia.)

S = stainless steel

W = wire reinforcement (4–12 mm dia.)

T (at the end) = located in top of member

abr = alternate bars reversed (useful for offsets)

Thus, bar mk.2 = 2R10-2-200T or, ②RØ10-200-T-00

and mk.3 = 10R8-3-270 or, ③10RØ8-270-54

All but the most obscure reinforcement shapes are illustrated in the British Standard. For the beam referred to on page 596, the standard listing is:

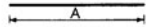
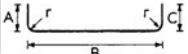
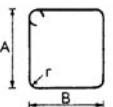
BS code	Shape	Total bar length on centre line (mm)
00		A
21		A + B + C - r - 2c (d = bar diameter)
54		2(A + B) + 12d

Ref. BS EN ISO 3766: Construction drawings. Simplified representation of concrete reinforcement.

# Identification of Concrete Reinforcement

Bar Schedule ~ this can be derived from the coding explained on the previous page. Assuming 10 No. beams are required:-

Site ref ..... Schedule ref .....

Prepared by ..... Date .....

Member	Bar mark	Type and size	No. of members	No. of bars in each	Total no.	Bar length (mm)	Shape code	A	B	C	D	E/r
Beam	1	T20	10	2	20	3080	21	200	2700	200		
	2	R10	10	2	20	2700	00	2700				
	3	RB	10	10	100	1336	54	400	220			

Note:  $r = 2 \times d$  for mild steel  
 $3 \times d$  for high yield steel

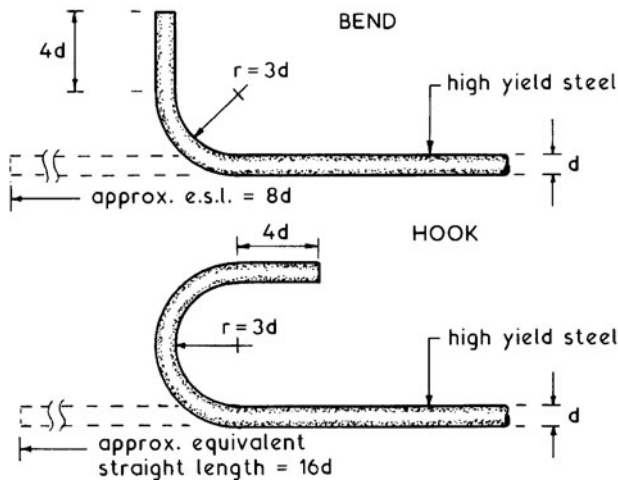

Bar coding ~

1st character	2nd character
0 No bends	0 Straight bars
1 1 bend	1 90° bends, standard radius, all bends towards same direction
2 2 bends	2 90° bends, non-standard radius, all bends towards same direction
3 3 bends	3 180° bends, non-standard radius, all bends towards same direction
4 4 bends	4 90° bends, standard radius, not all bends towards same direction
5 5 bends	5 Bends <90°, standard radius, all bends towards same direction
6 Arcs of circles	6 Bends <90°, standard radius, not all bends towards same direction
7 Complete helices	7 Arcs or helices

NB. 9 is used for special or non-standard shapes.

## Types of Reinforcement – Steel Bars

Material ~ Mild steel or high yield steel. Both contain about 99% iron, the remaining constituents are manganese, carbon, sulphur and phosphorus. The proportion of carbon determines the quality and grade of steel; mild steel has 0.25% carbon, high yield steel 0.40%. High yield steel may also be produced by cold working or deforming mild steel until it is strain hardened. Mild steel has the letter R preceding the bar diameter in mm, e.g. R20, and high yield steel the letter T or Y.

Standard bar diameters ~ 6, 8, 10, 12, 16, 20, 25, 32 and 40 mm.

Grade notation:

- Mild steel – grade 250 or 250 N/mm<sup>2</sup> characteristic tensile strength (0.25% carbon, 0.06% sulphur and 0.06% phosphorus).
- High yield steel – grade 460/425 (0.40% carbon, 0.05% sulphur and 0.05% phosphorus).

460 N/mm<sup>2</sup> characteristic tensile strength: 6, 8, 10, 12 and 16 mm diameter.

425 N/mm<sup>2</sup> characteristic tensile strength: 20, 25, 32 and 40 mm diameter.

Examples of steel reinforcement ~

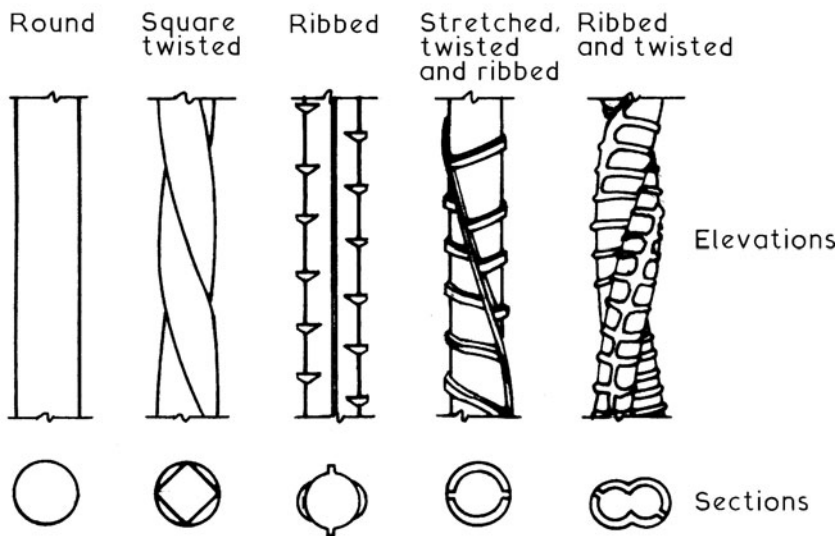

Ref. BS 4449: Steel for the reinforcement of concrete, weldable reinforcing steel. Bar, coil and decoiled product. Specification.

## Types of Reinforcement – Steel Mesh

Steel reinforcement mesh or fabric is produced in four different formats for different applications:

Format	Type	Typical application
A	Square mesh	Floor slabs
B	Rectangular mesh	Floor slabs
C	Long mesh	Roads and pavements
D	Wrapping mesh	Binding wire with concrete fire protection to structural steelwork

Standard sheet size ~ 4.8 m long × 2.4 m wide.

Standard roll size ~ 48 and 72 m long × 2.4 m wide.

Specification ~ format letter plus a reference number. This number equates to the cross sectional area in mm<sup>2</sup> of the main bars per metre width of mesh.

E.g. B385 is rectangular mesh with 7 mm dia. main bars, i.e. 10 bars of 7 mm dia. @ 100 mm spacing = 385 mm<sup>2</sup>.

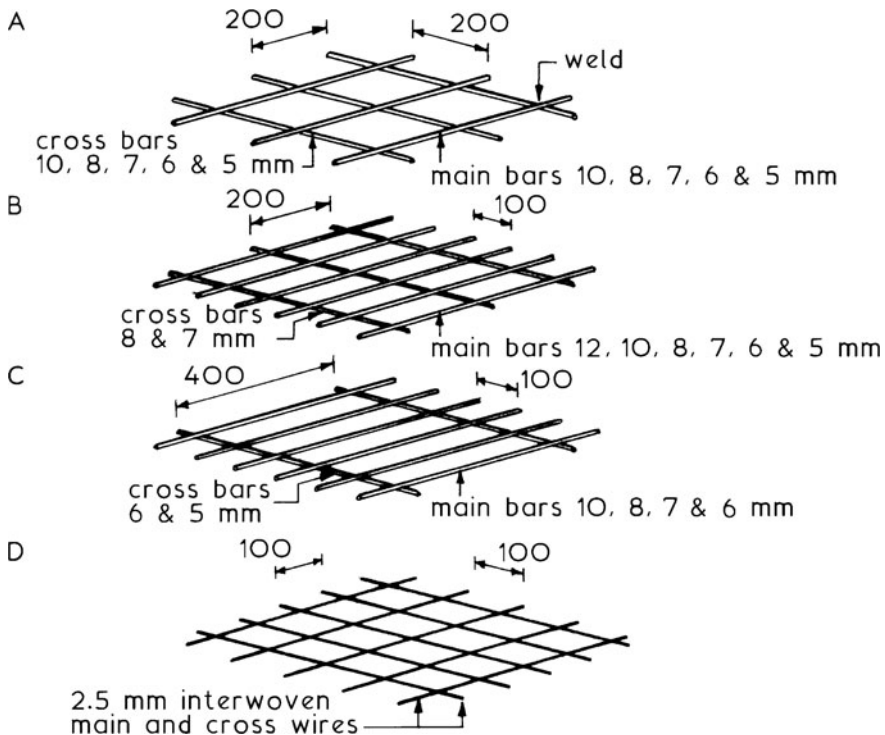

Refs.: BS 4483: Steel fabric for the reinforcement of concrete. Specification.

BS 4482: Steel wire for the reinforcement of concrete products. Specification.

## Concrete Cover to Reinforcing Steel

Cover to reinforcement in columns, beams, foundations, etc. is required for the following reasons:

- To protect the steel against corrosion.
- To provide sufficient bond or adhesion between steel and concrete.
- To ensure sufficient protection of the steel in a fire (see Note).

If the cover is insufficient, concrete will spall away from the steel.

Minimum cover ~ never less than the maximum size of aggregate in the concrete, or the largest reinforcement bar size (take greater value).

Guidance on minimum cover for particular locations ~

Below ground:

- Foundations, retaining walls, basements, etc., 40 mm, binders 25 mm.
- Marine structures, 65 mm, binders 50 mm.
- Uneven earth and fill 75 mm, blinding 40 mm.

Above ground:

- Ends of reinforcing bars, not less than 25 mm nor less than  $2 \times$  bar diameter.
- Column longitudinal reinforcement 40 mm, binders 20 mm.
- Columns <190 mm min. dimension with bars <12 mm dia., 25 mm.
- Beams 25 mm, binders 20 mm.
- Slabs 20 mm (15 mm where max. aggregate size is <15 mm).

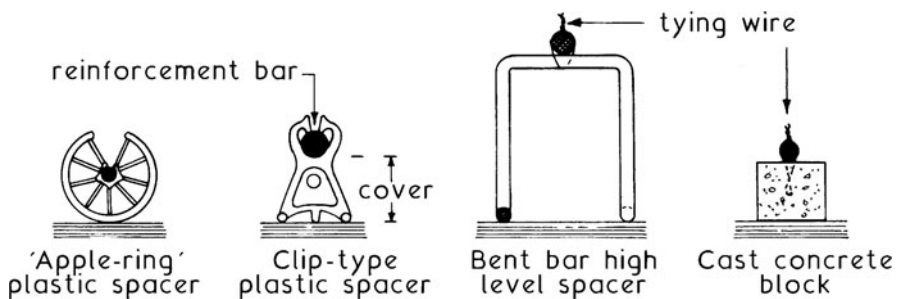

Note: Minimum cover for corrosion protection and bond may not be sufficient for fire protection and severe exposure situations.

For details of fire protection see Refs.:

Building Regulations, Approved Document B: Fire safety.

BS EN 1992-1-1: Design of concrete structures. General rules and rules for buildings.

BS EN 1992-1-2: Design of concrete structures. General rules. Structural fire design.

For general applications, including exposure situations, see next page.

Typical examples using dense concrete of calcareous aggregates (excluding limestone) or siliceous aggregates, e.g. flints, quartzites and granites ~

## Column fully exposed ~

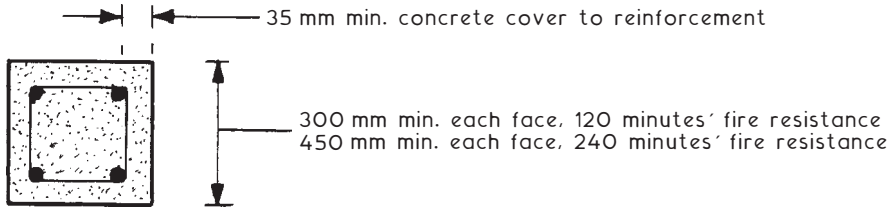

## Column, maximum 50% exposed ~

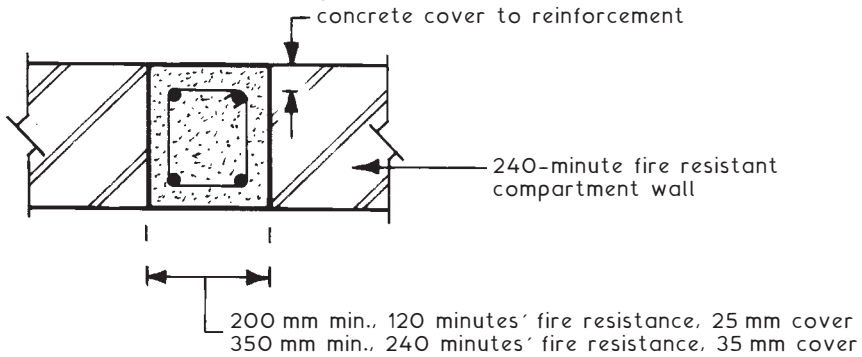

## Column, one face only exposed ~

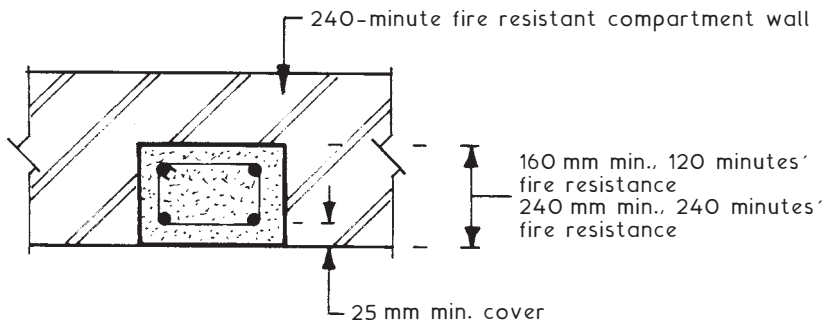

## Beam and floor slab ~

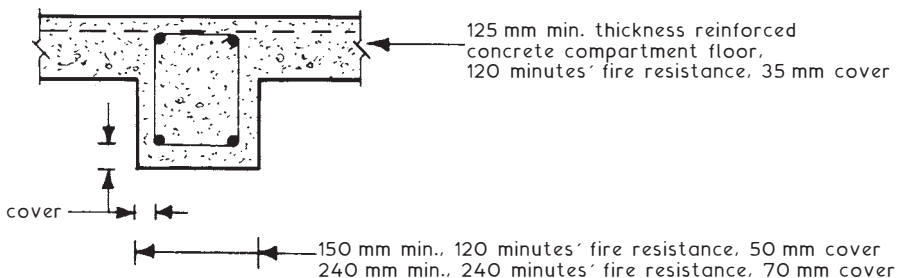

## Basic Formwork – Details

Formwork ~ concrete when first mixed is a fluid and therefore to form any concrete member the wet concrete must be placed in a suitable mould to retain its shape, size and position as it sets. It is possible with some forms of concrete foundations to use the sides of the excavation as the mould but in most cases when casting concrete members a mould will have to be constructed on site. These moulds are usually called formwork. It is important to appreciate that the actual formwork is the reverse shape of the concrete member which is to be cast.

Falsework ~ the temporary structure which supports the formwork.

Principles ~

formwork sides can be designed to offer all the necessary resistance to the imposed pressures as a single member or alternatively they can be designed to use a thinner material which is adequately strutted – for economic reasons the latter method is usually employed

grout tight joints

formwork soffits can be designed to offer all the necessary resistance to the imposed loads as a single member or alternatively they can be designed to a thinner material which is adequately propped – for economic reasons the latter method is usually employed

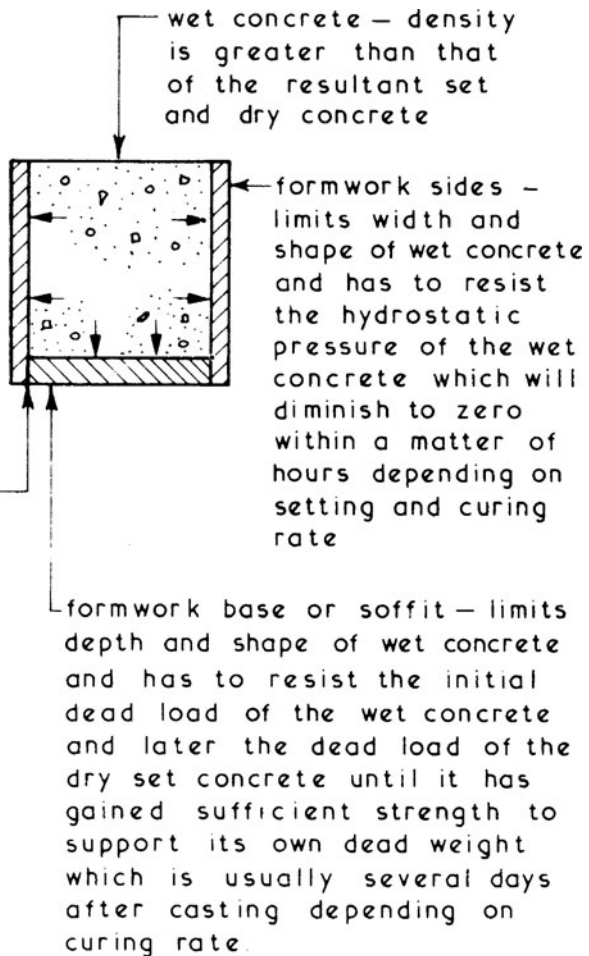

Typical Simple Beam Formwork Details ~

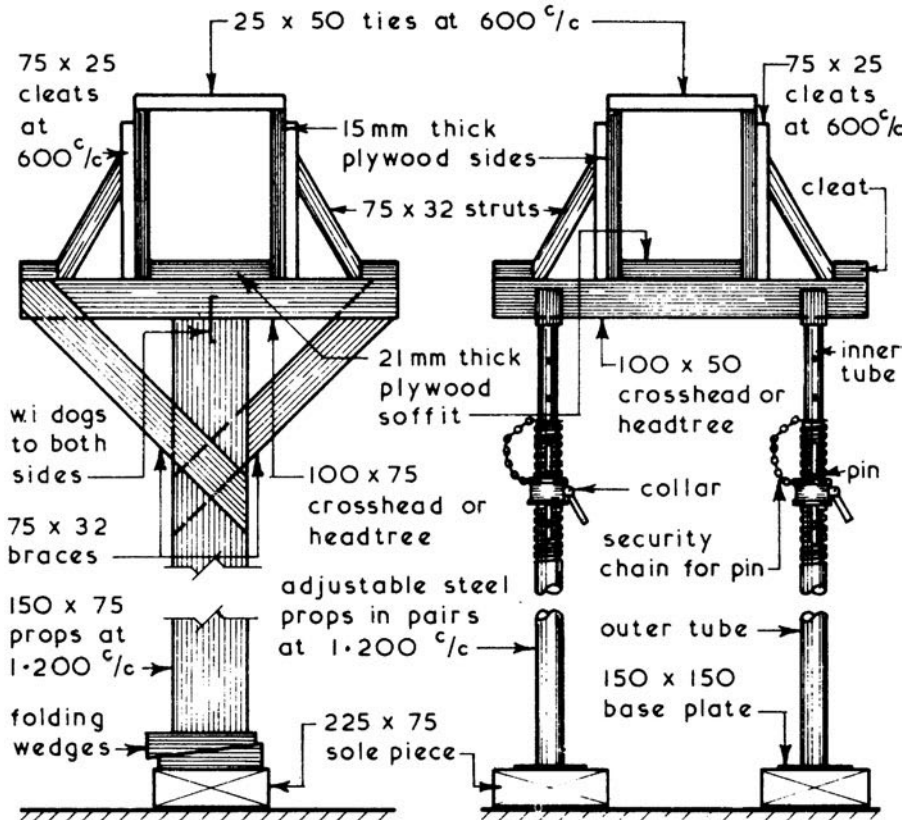

SINGLE PROP SUPPORT

DOUBLE PROP SUPPORT

Erecting Formwork

1. Props positioned and levelled through.
2. Soffit placed, levelled and position checked.
3. Side forms placed, their position checked before being fixed.
4. Strutting position and fixed.
5. Final check before casting.

Striking or Removing Formwork

1. Side forms as soon as practicable usually within hours of casting this allows drying air movements to take place around the setting concrete.
2. Soffit formwork as soon as practicable usually within days but as a precaution some props are left in position until concrete member is self-supporting.

Suitable Formwork Materials ~ timber, steel and special plastics.



## Formwork – Beams

Beam Formwork ~ this is basically a three-sided box supported and propped in the correct position and to the desired level. The beam formwork sides have to retain the wet concrete in the required shape and be able to withstand the initial hydrostatic pressure of the wet concrete whereas the formwork soffit apart from retaining the concrete has to support the initial load of the wet concrete and finally the set concrete until it has gained sufficient strength to be self-supporting. It is essential that all joints in the formwork are constructed to prevent the escape of grout which could result in honeycombing and/or feather edging in the cast beam. The removal time for the formwork will vary with air temperature, humidity and consequent curing rate.

Typical Details ~

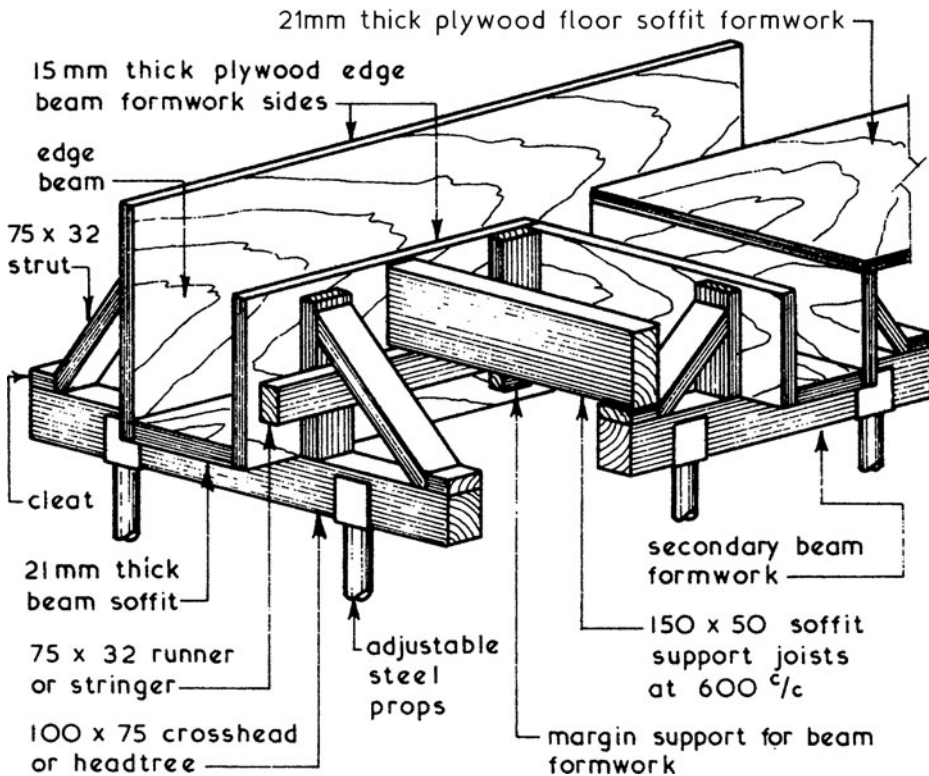

Typical Formwork Striking Times ~

Beam Sides - 9 to 12 hours	} Using OPC air temp 7 to 16°C
Beam Soffits - 8 to 14 days (props left under)	
Beam Props - 15 to 21 days	

Column Formwork ~ this consists of a vertical mould of the desired shape and size which has to retain the wet concrete and resist the initial hydrostatic pressure caused by the wet concrete. To keep the thickness of the formwork material to a minimum horizontal clamps or yokes are used at equal centres for batch filling and at varying centres for complete filling in one pour. The head of the column formwork can be used to support the incoming beam formwork which gives good top lateral restraint but results in complex formwork. Alternatively the column can be cast to the underside of the beams and at a later stage a collar of formwork can be clamped around the cast column to complete casting and support the incoming beam formwork. Column forms are located at the bottom around a 75 to 100 mm high concrete plinth or kicker which has the dual function of location and preventing grout loss from the bottom of the column formwork.

Typical Details ~

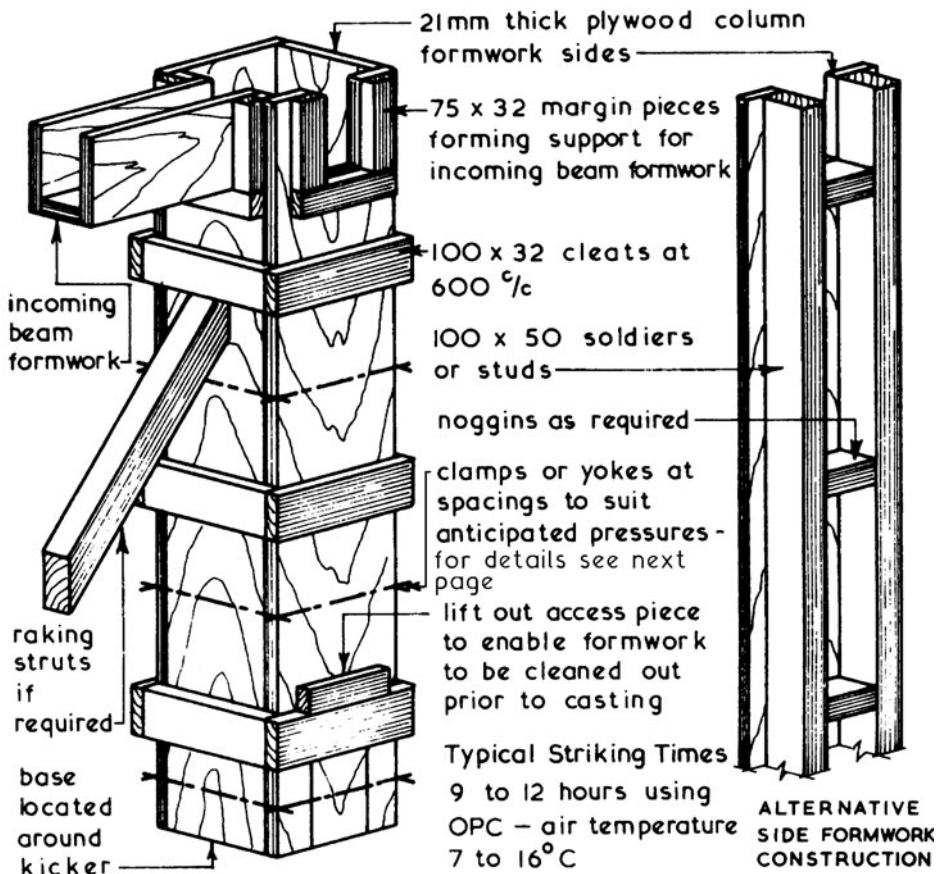

# Formwork – Column Clamps and Yokes

Column Yokes ~ these are obtainable as a metal yoke or clamp or they can be purpose made from timber.

Typical Examples ~

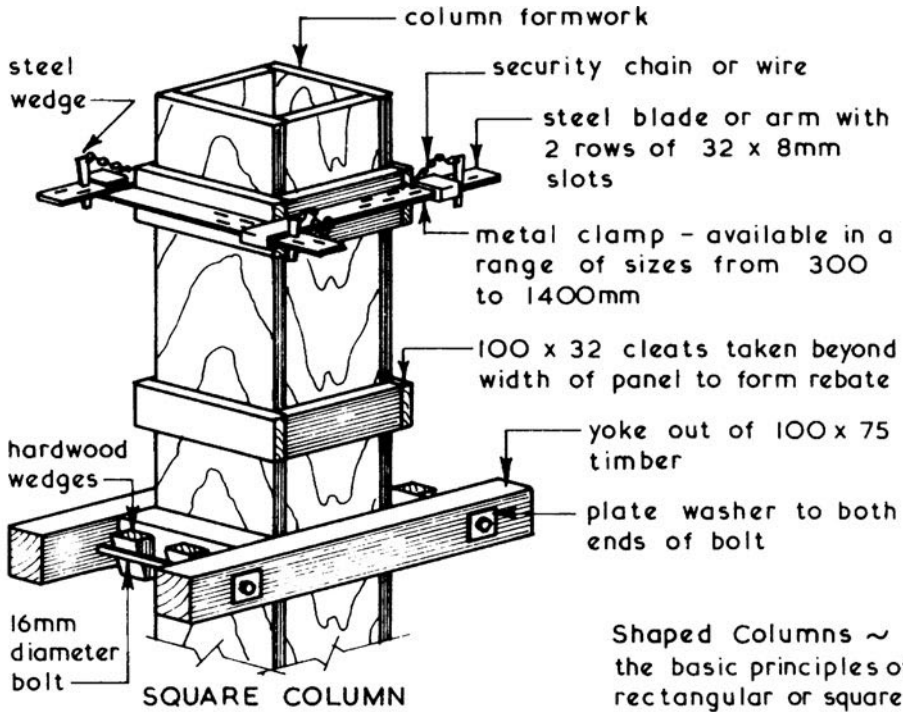

gangnail or plywood connecting plates to both faces

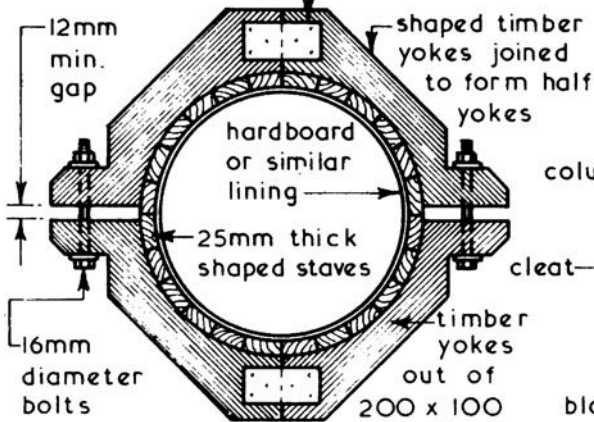

Shaped Columns ~ the basic principles of rectangular or square columns are followed but purpose-made shaped yokes are sometimes required. Rebated columns can be formed with blocks or boxing thus -

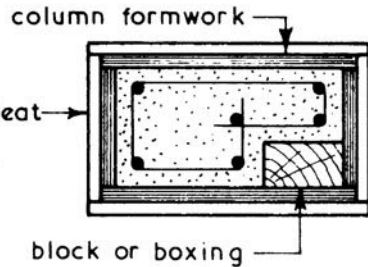

Wall Forms ~ conventionally made up of plywood sheeting that may be steel, plastic or wood faced for specific concrete finishes. Stability is provided by vertical studs and horizontal walings retained in place by adjustable props. Base location is by a kicker of 50 or 75mm height of width to suit the wall thickness. Spacing of wall forms is shown on the next page.

Wall formwork principles ~

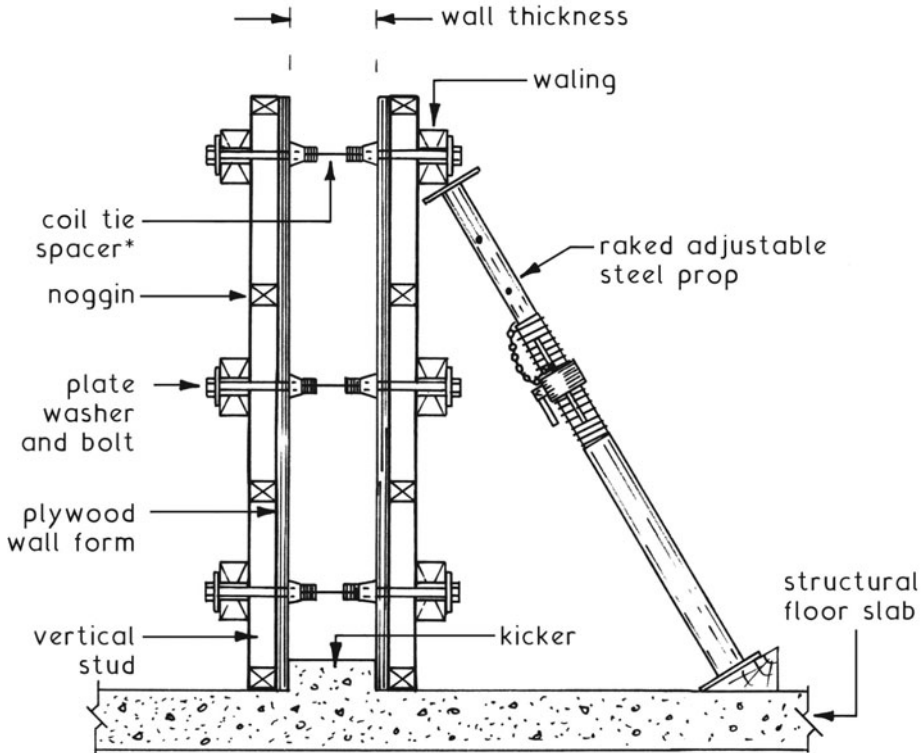

Refs.: BS 6100-9: Building and civil engineering. Vocabulary. Work with concrete and plaster.

BS 8000-2.2: Workmanship on building sites. Code of practice for concrete work. Sitework with in-situ and precast concrete.

BRE Report 495: Concrete frame buildings, modular formwork.

\*See next page and page 294.

## Formwork – Wall Form Spacing

Formwork sides to concrete walls of modest height and load can be positioned with long bolts or threaded dowel bars inserted through the walings on opposing sides. To keep the wall forms apart, tube spacers are placed over the bolts between the forms. For greater load applications, variations include purpose-made high tensile steel bolts or dowels. These too are sleeved with plastic tubes and have removable spacer cones inside the forms. Surface voids from the spacers can be made good with strong mortar. Some examples are shown below with the alternative coil tie system. Further applications are shown on pages 294 to 296.

### Bolt

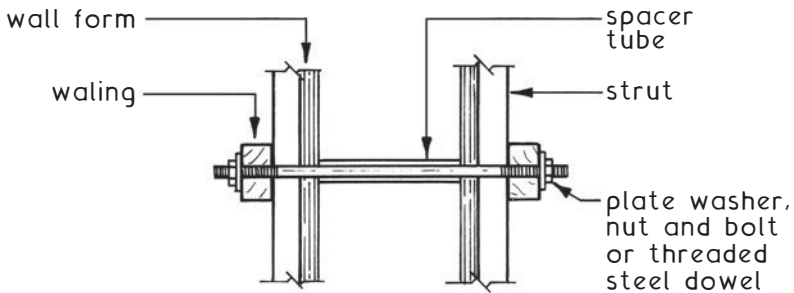

### Coil tie

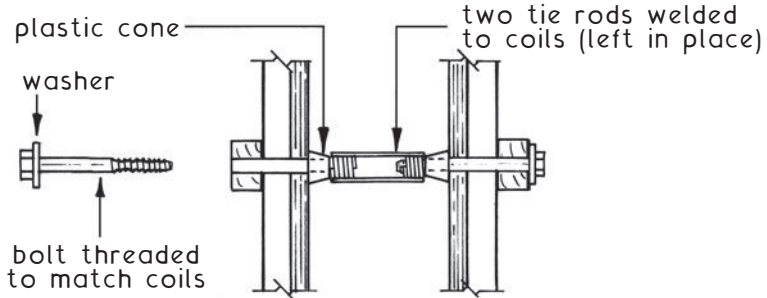

### Tie bolt

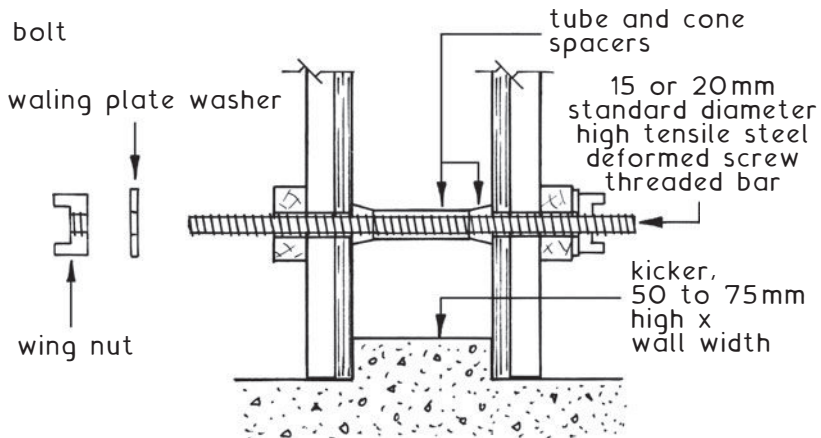

Precast Concrete Frames ~ these frames are suitable for single storey and low rise applications, the former usually in the form of portal frames which are normally studied separately. Precast concrete frames provide the skeleton for the building and can be clad externally and finished internally by all the traditional methods. The frames are usually produced as part of a manufacturer's standard range of designs and are therefore seldom purpose made due mainly to the high cost of the moulds.

Advantages:

1. Frames are produced under factory-controlled conditions resulting in a uniform product of both quality and accuracy.
2. Repetitive casting lowers the cost of individual members.
3. Off-site production releases site space for other activities.
4. Frames can be assembled in cold weather and generally by semi-skilled labour.

Disadvantages:

1. Although a wide choice of frames is available from various manufacturers these systems lack the design flexibility of cast in-situ purpose-made frames.
2. Site planning can be limited by manufacturer's delivery and unloading programmes and requirements.
3. Lifting plant of a type and size not normally required by traditional construction methods may be needed.

Typical Site Activities ~

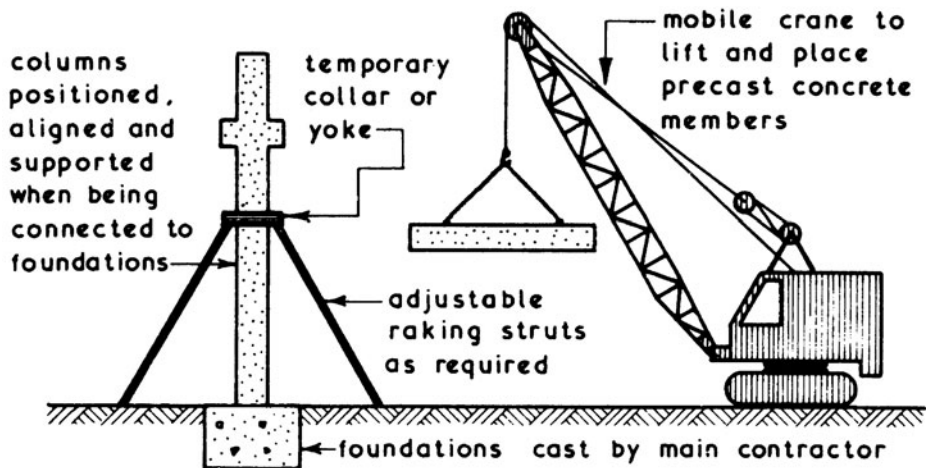

# Precast Concrete Frames

Foundation Connections ~ the preferred method of connection is to set the column into a pocket cast into a reinforced concrete pad foundation and is suitable for light to medium loadings. Where heavy column loadings are encountered it may be necessary to use a steel base plate secured to the reinforced concrete pad foundation with holding down bolts.

Typical Details ~

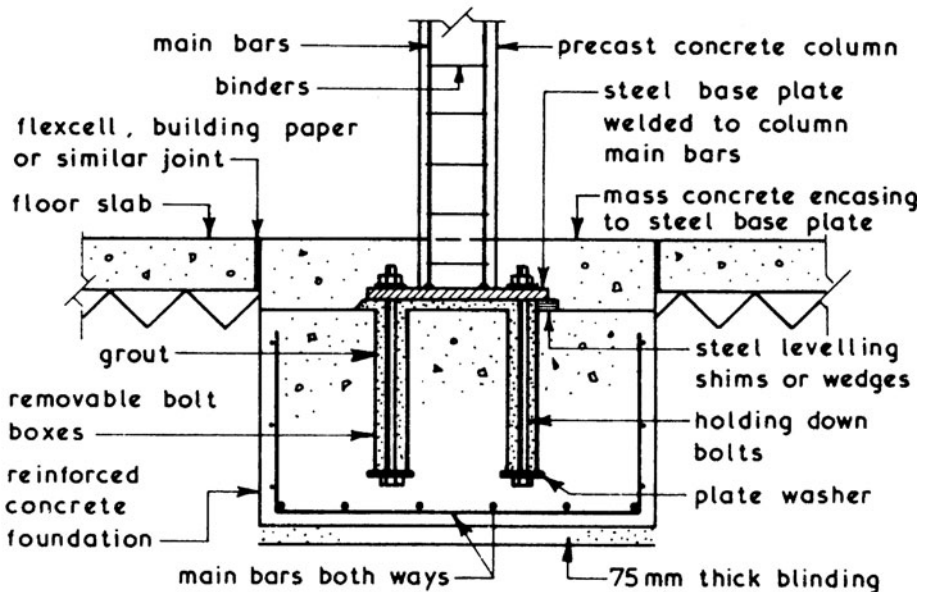
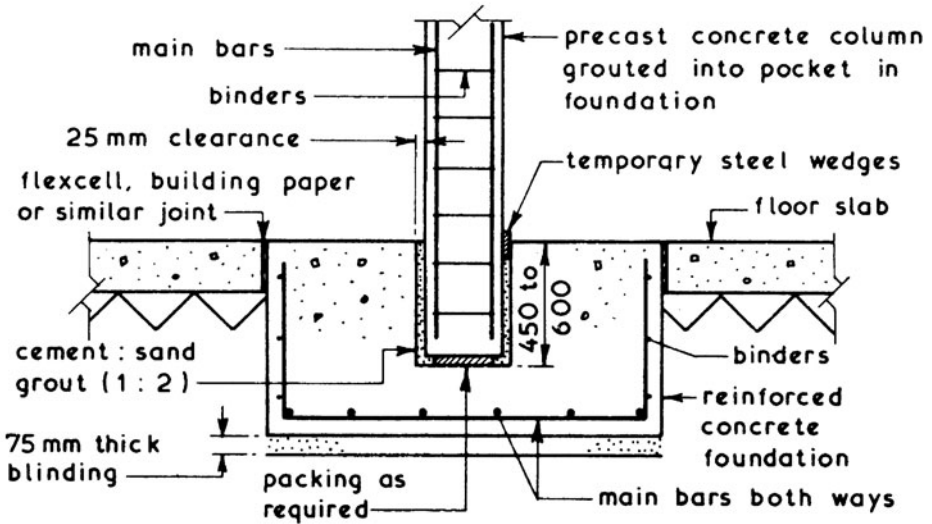

Column to Column Connection ~ precast columns are usually cast in one length and can be up to four storeys in height. They are either reinforced with bar reinforcement or they are prestressed according to the loading conditions. If column to column are required they are usually made at floor levels above the beam to column connections and can range from a simple dowel connection to a complex connection involving in-situ concrete.

Typical Details ~

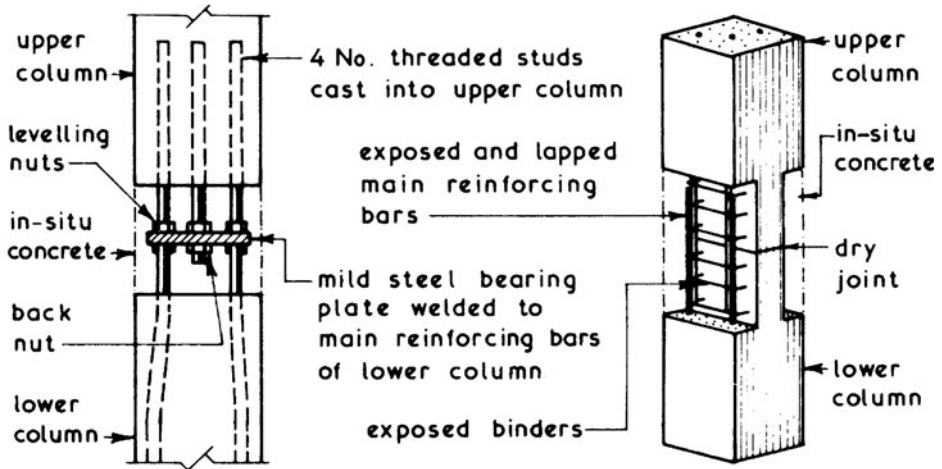
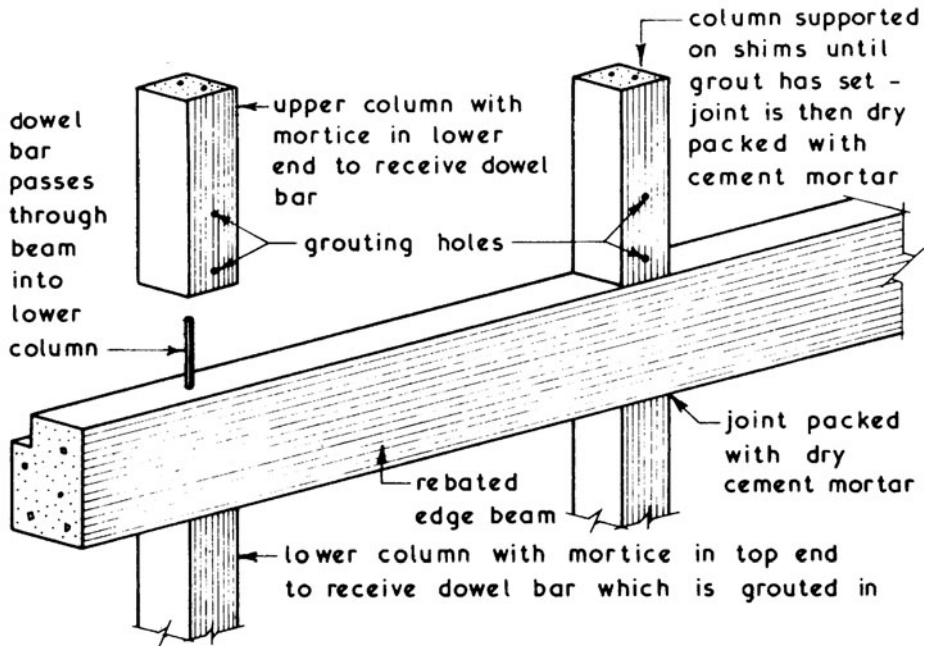



# Precast Concrete Frames

Beam to Column Connections ~ as with the column to column connections (see previous page) the main objective is to provide structural continuity at the junction. This is usually achieved by one of two basic methods:

1. Projecting bearing haunches cast onto the columns with a projecting dowel or stud bolt to provide both location and fixing.
2. Steel to steel fixings which are usually in the form of a corbel or bracket projecting from the column providing a bolted connection to a steel plate cast into the end of the beam.

Typical Details ~

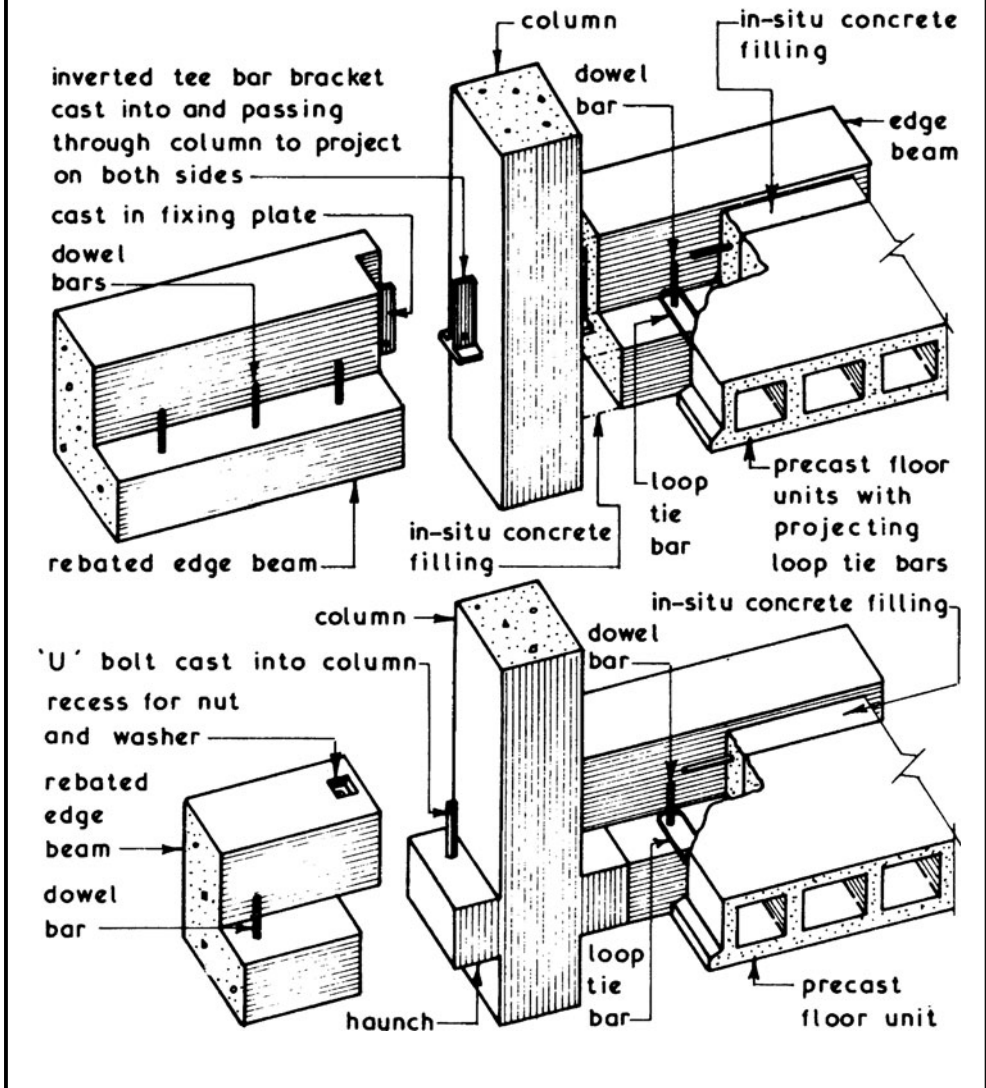

Principles ~ the well known properties of concrete are that it has high compressive strength and low tensile strength. The basic concept of reinforced concrete is to include a designed amount of steel bars in a predetermined pattern to give the concrete a reasonable amount of tensile strength. In prestressed concrete a precompression is induced into the member to make full use of its own inherent compressive strength when loaded. The design aim is to achieve a balance of tensile and compressive forces so that the end result is a concrete member which is resisting only stresses which are compressive. In practice a small amount of tension may be present but providing this does not exceed the tensile strength of the concrete being used tensile failure will not occur.

Comparison of Reinforced and Prestressed Concrete ~

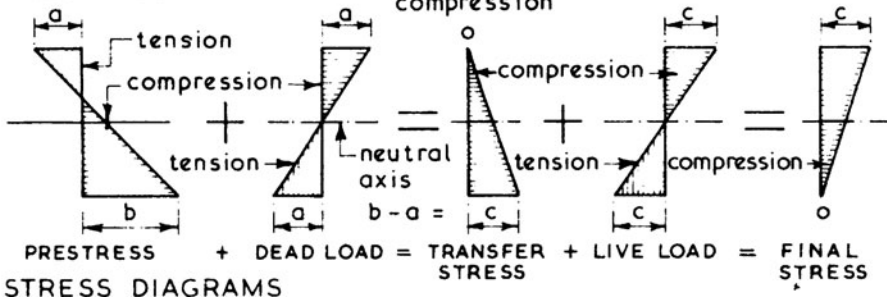
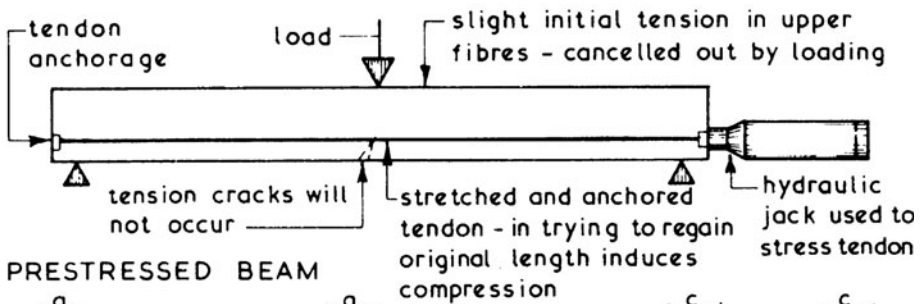
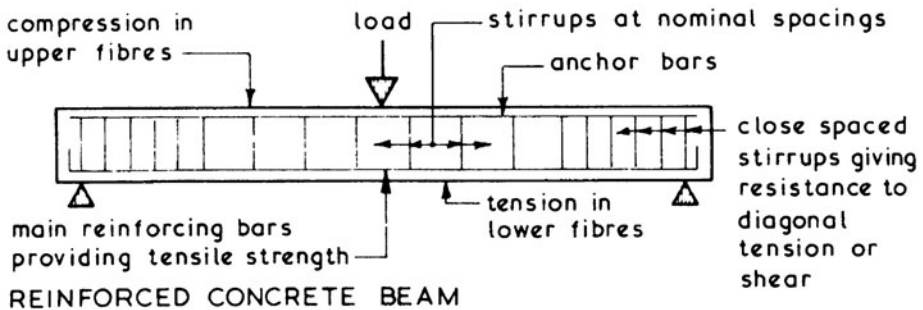

# Prestressed Concrete

Materials ~ concrete will shrink whilst curing and it can also suffer sectional losses due to creep when subjected to pressure. The amount of shrinkage and creep likely to occur can be controlled by designing the strength and workability of the concrete, high strength and low workability giving the greatest reduction in both shrinkage and creep. Mild steel will suffer from relaxation losses which is where the stresses in steel under load decrease to a minimum value after a period of time and this can be overcome by increasing the initial stress in the steel. If mild steel is used for prestressing the summation of shrinkage, creep and relaxation losses will cancel out any induced compression, therefore special alloy steels must be used to form tendons for prestressed work.

Tendons - these can be of small diameter wires (2 to 7 mm) in a plain round, crimped or indented format; these wires may be individual or grouped to form cables. Another form of tendon is strand which consists of a straight core wire around which is helically wound further wires to give formats such as 7 wire (6 over 1) and 19 wire (9 over 9 over 1) and like wire tendons strand can be used individually or in groups to form cables. The two main advantages of strand are:

1. A large prestressing force can be provided over a restricted area.
2. Strand can be supplied in long flexible lengths capable of being stored on drums, thus saving site storage and site fabrication space.

## Typical Tendon Formats ~

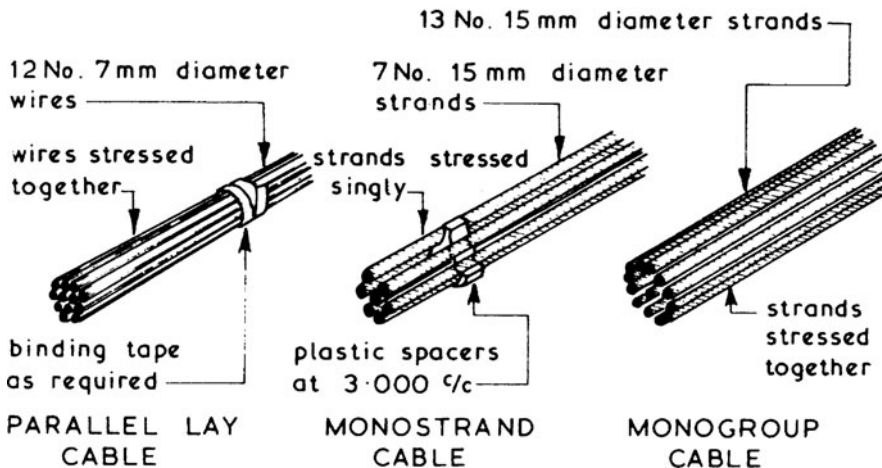

Pre-tensioning ~ this method is used mainly in the factory production of precast concrete components such as lintels, floor units and small beams. Many of these units are formed by the long line method where precision steel moulds up to 120·000 long are used with spacer or dividing plates to form the various lengths required. In pre-tensioning the wires are stressed within the mould before the concrete is placed around them. Steam curing is often used to accelerate this process to achieve a 24-hour characteristic strength of  $28\text{ N/mm}^2$  with a typical 28-day cube strength of  $40\text{ N/mm}^2$ . Stressing of the wires is carried out by using hydraulic jacks operating from one or both ends of the mould to achieve an initial 10% overstress to counteract expected losses. After curing the wires are released or cut and the bond between the stressed wires and the concrete prevents the tendons from regaining their original length, thus maintaining the precompression or prestress.

At the extreme ends of the members the bond between the stressed wires and concrete is not fully developed due to low frictional resistance. This results in a small contraction and swelling at the ends of the wire forming in effect a cone shape anchorage. The distance over which this contraction occurs is called the transfer length and is equal to 80 to 120 times the wire diameter. To achieve a greater total surface contact area it is common practice to use a larger number of small diameter wires rather than a smaller number of large diameter wires giving the same total cross sectional area.

Typical Pre-tensioning Arrangement ~

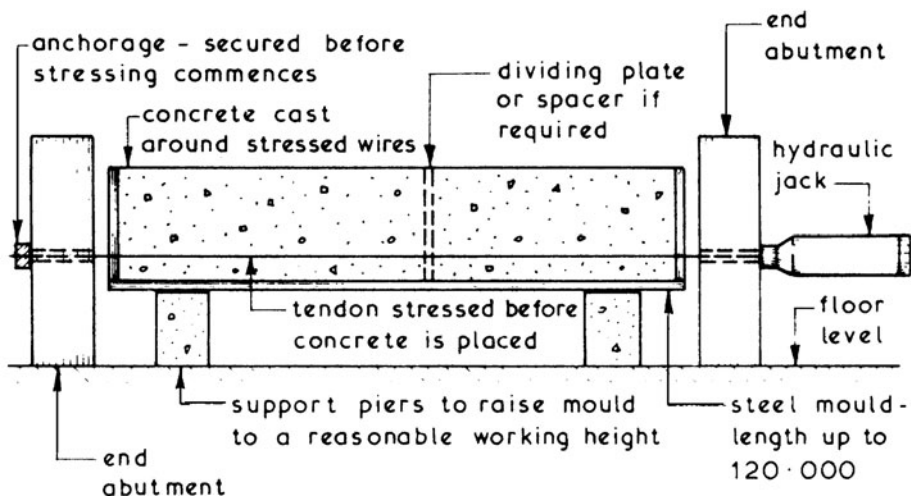

# Prestressed Concrete

Post-tensioning ~ this method is usually employed where stressing is to be carried out on site after casting an in-situ component or where a series of precast concrete units are to be joined together to form the required member. It can also be used where curved tendons are to be used to overcome negative bending moments. In post-tensioning the concrete is cast around ducts or sheathing in which the tendons are to be housed. Stressing is carried out after the concrete has cured by means of hydraulic jacks operating from one or both ends of the member. The anchorages (see next page) which form part of the complete component prevent the stressed tendon from regaining its original length, thus maintaining the precompression or prestress. After stressing the annular space in the tendon ducts should be filled with grout to prevent corrosion of the tendons due to any entrapped moisture and to assist in stress distribution. Due to the high local stresses at the anchorage positions it is usual for a reinforcing spiral to be included in the design.

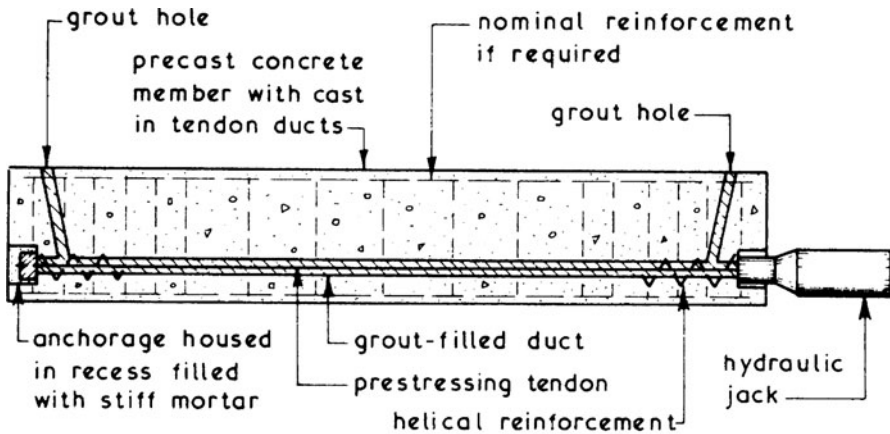

## Curved Tendons for Negative Bending Moments ~

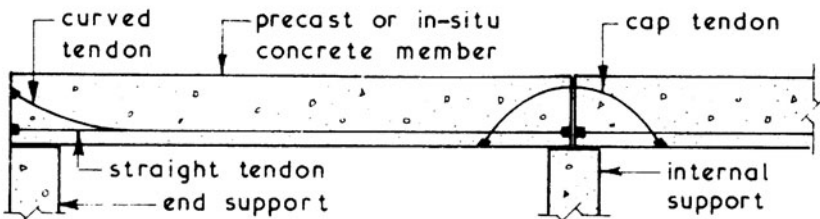

Typical Post-tensioning Arrangement ~

Anchorage ~ the formats for anchorages used in conjunction with post-tensioned prestressed concrete works depends mainly on whether the tendons are to be stressed individually or as a group, but most systems use a form of split cone wedges or jaws acting against a form of bearing or pressure plate.

Typical Anchorage Details ~

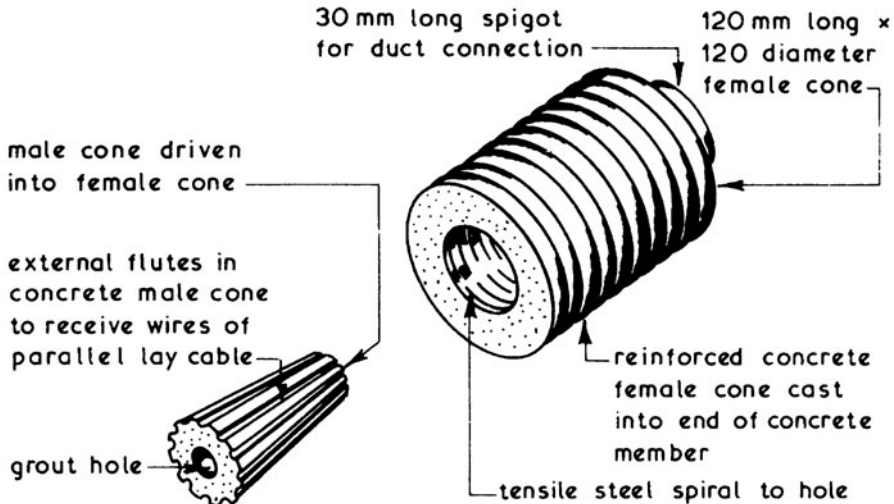

FREYSSINET ANCHORAGE

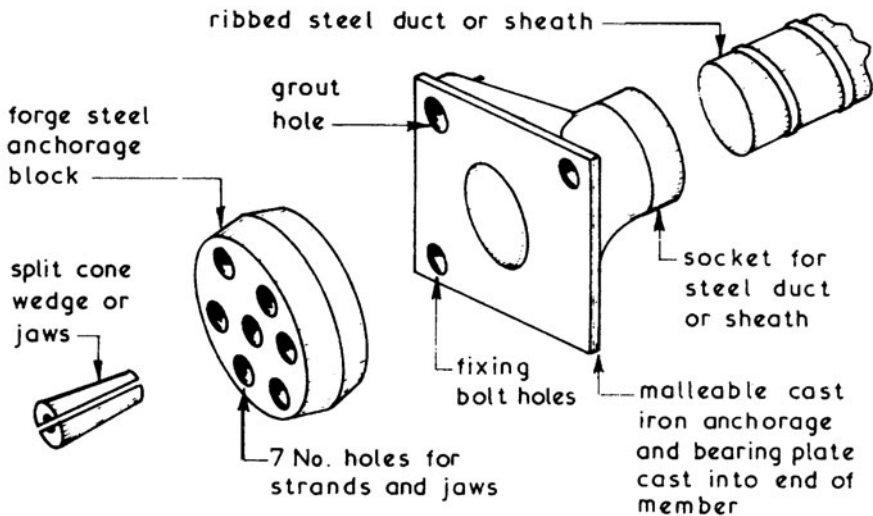

TYPICAL MONOSTRAND ANCHORAGE

## Prestressed Concrete

Comparison with Reinforced Concrete ~ when comparing prestressed concrete with conventional reinforced concrete the main advantages and disadvantages can be enumerated but in the final analysis each structure and/or component must be decided on its own merit.

Main advantages:

1. Makes full use of the inherent compressive strength of concrete.
2. Makes full use of the special alloy steels used to form the prestressing tendons.
3. Eliminates tension cracks, thus reducing the risk of corrosion of steel components.
4. Reduces shear stresses.
5. For any given span and loading condition a component with a smaller cross section can be used, thus giving a reduction in weight.
6. Individual precast concrete units can be joined together to form a composite member.

Main Disadvantages:

1. High degree of control over materials, design and quality of workmanship is required.
2. Special alloy steels are dearer than most traditional steels used in reinforced concrete.
3. Extra cost of special equipment required to carry out the prestressing activities.
4. Cost of extra safety requirements needed whilst stressing tendons.

As a general comparison between the two structural options under consideration it is usually found that:

1. Up to 6·000 span traditional reinforced concrete is the most economic method.
2. Spans between 6·000 and 9·000 the two cost options are comparable.
3. Over 9·000 span prestressed concrete is more economical than reinforced concrete.

It should be noted that generally columns and walls do not need prestressing but in tall columns and high retaining walls where the bending stresses are high, prestressing techniques can sometimes be economically applied.

Ground Anchors ~ these are a particular application of post-tensioning prestressing techniques and can be used to form ground tie backs to cofferdams, retaining walls and basement walls. They can also be used as vertical tie downs to basement and similar slabs to prevent flotation during and after construction. Ground anchors can be of a solid bar format (rock anchors) or of a wire or cable format for granular and cohesive soils. A lined or unlined borehole must be drilled into the soil to the design depth and at the required angle to house the ground anchor. In clay soils the borehole needs to be underreamed over the anchorage length to provide adequate bond. The tail end of the anchor is pressure grouted to form a bond with the surrounding soil, the remaining length being unbonded so that it can be stressed and anchored at head, thus inducing the prestress. The void around the unbonded or elastic length is gravity grouted after completion of the stressing operation.

Typical Ground Anchor Details ~

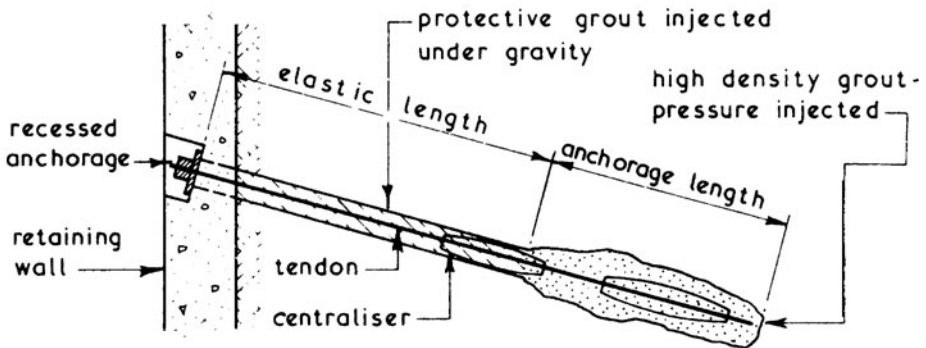

GROUND ANCHOR FOR GRANULAR SOILS

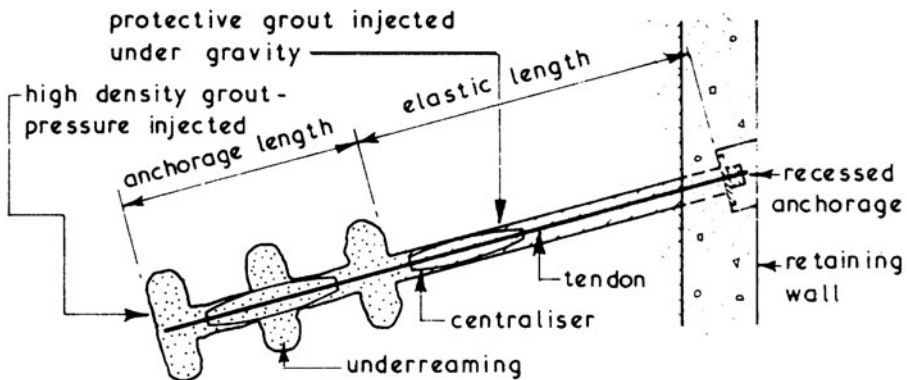

GROUND ANCHOR FOR COHESIVE SOILS



## Structural Steelwork – Standard Cold Rolled Sections

Cold rolled steel sections are a lightweight alternative to the relatively heavy, hot rolled steel sections that have been traditionally used in sub-framing situations, e.g. purlins, joists and sheeting rails. Cold rolled sections are generally only a few millimetres in wall thickness, saving on material and handling costs and building dead load. They are also produced in a wide variety of section profiles, some of which are shown below.

Typical section profiles ~

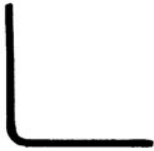

Equal angle

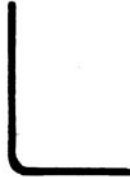

Unequal angle

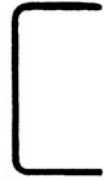

Plain channel

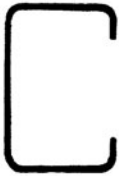

Lipped inward channel

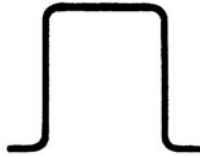

Lipped outward channel

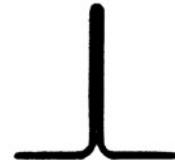

Tee

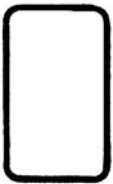

Square or rectangular

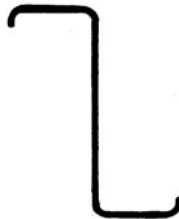

Zed



Sigma

Dimensions vary considerably and many non-standard profiles are made for particular situations. A range of standard sections are produced to:

BS EN 10162: Cold rolled steel sections. Technical delivery conditions. Dimensional and cross sectional tolerances.

# Structural Steelwork – Standard Hot Rolled Sections

Structural Steelwork ~ standard section references:

BS 4-1: Structural steel sections. Specification for hot rolled sections.

BS EN 10056: Specification for structural steel equal and unequal angles.

BS EN 10210: Hot finished structural hollow sections of non-alloy and fine grain steels.

Typical Standard Steelwork Sections ~

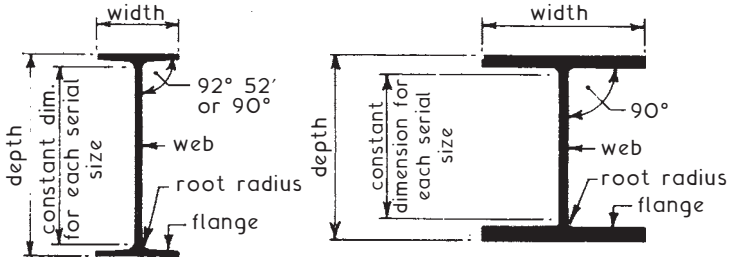

## UNIVERSAL BEAMS

127 x 76 x 13 kg/m to  
914 x 419 x 388 kg/m

## UNIVERSAL COLUMNS

152 x 152 x 23 kg/m to  
356 x 406 x 634 kg/m

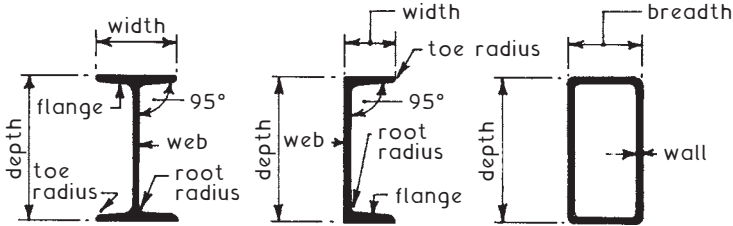

## JOISTS

76 x 76 x 13 kg/m to  
254 x 203 x 82 kg/m

## CHANNELS

100 x 50 x 10 kg/m to  
430 x 100 x 64 kg/m

## HOLLOW SECTIONS

50 x 30 x 2.89 kg/m to  
500 x 300 x 191 kg/m

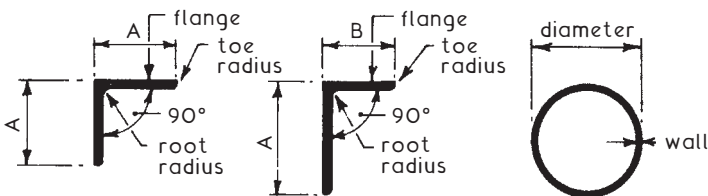

## EQUAL ANGLES

25 x 25 x 1.2 kg/m to  
200 x 200 x 71.1 kg/m

## UNEQUAL ANGLES

40 x 25 x 1.91 kg/m to  
200 x 150 x 47.1 kg/m

## HOLLOW SECTIONS

21.3 dia. x 1.43 kg/m to  
508 dia. x 194 kg/m

NB. Sizes given are serial or nominal, for actual sizes see relevant BS.

## Structural Steelwork – Compound Sections

Compound Sections - these are produced by welding together standard sections. Various profiles are possible, which can be designed specifically for extreme situations such as very high loads and long spans, where standard sections alone would be insufficient. Some popular combinations of standard sections include:

### BEAM or COLUMN

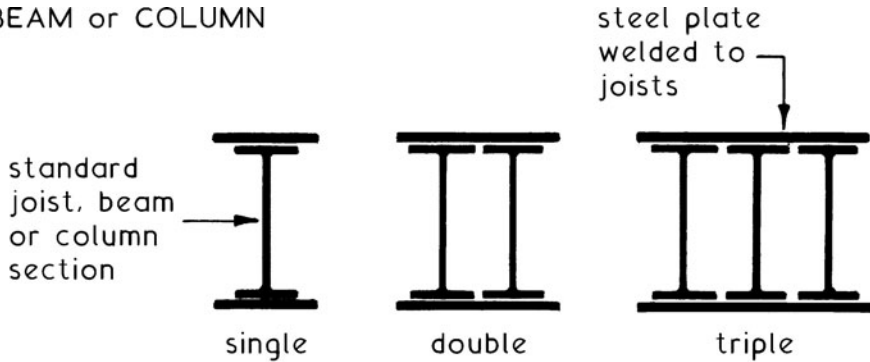

### CHANNEL

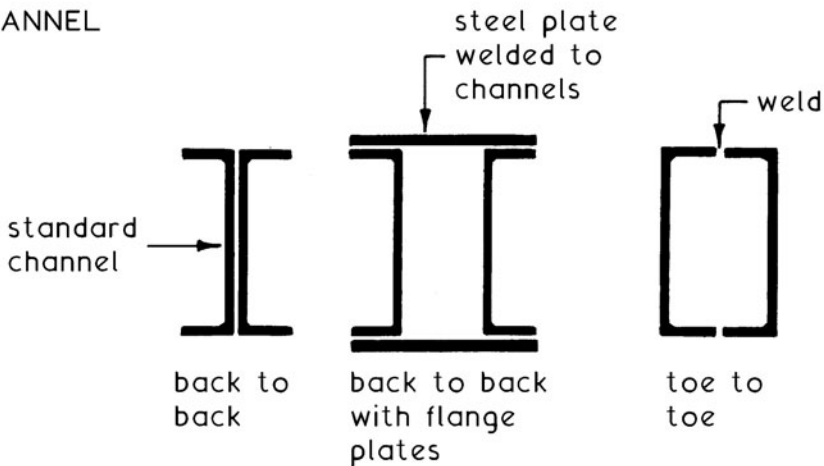

### GANTRY GIRDER

combination of standard channel, joist and plate sections welded together

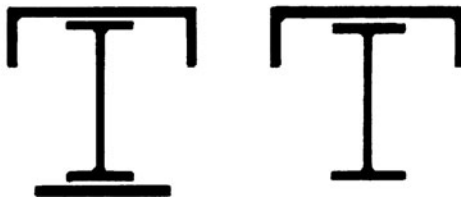

Open Web Beams - these are particularly suited to long spans with light to moderate loading. The relative increase in depth will help resist deflection and voids in the web will reduce structural dead load.

Perforated Beam - a standard beam section with circular voids cut about the neutral axis.

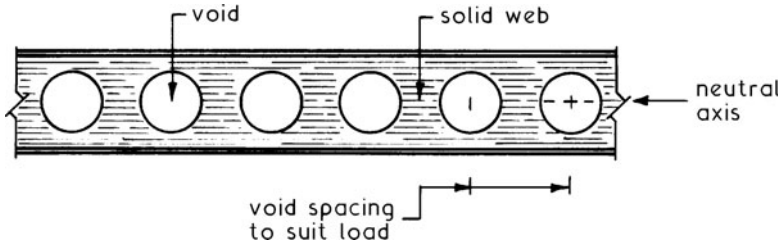

Castellated Beam - a standard beam section web is profile cut into two by oxy-acetylene torch. The projections on each section are welded together to create a new beam 50% deeper than the original.

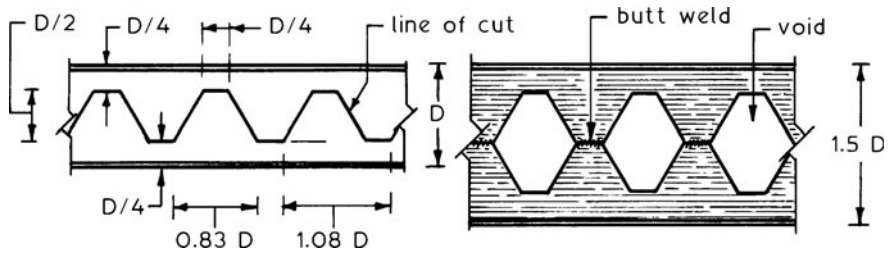

Litzka Beam - a standard beam cut as the castellated beam, but with overall depth increased further by using spacer plates welded to the projections. Minimal increase in weight.

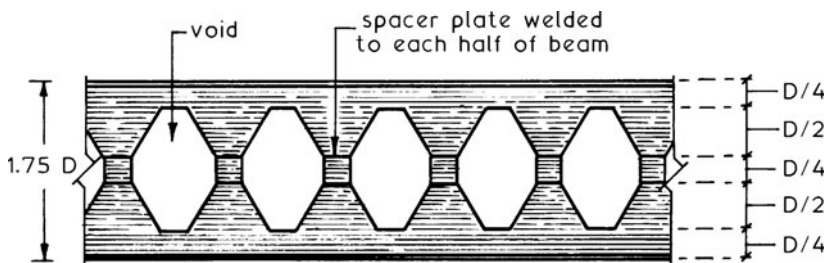

NB. Voids at the end of open web beams should be filled with a welded steel plate, as this is the area of maximum shear stress in a beam.

# Structural Steelwork – Lattice Beams

Lattices – these are an alternative type of open web beam, using standard steel sections to fabricate high depth to weight ratio units capable of spans up to about 15m. The range of possible components is extensive and some examples are shown below:

## PLATE GIRDER

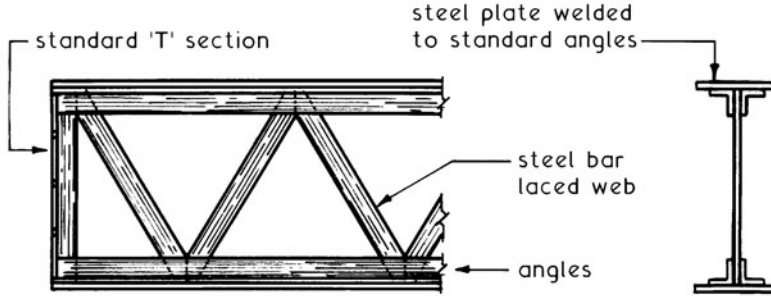

## TUBULAR LATTICE

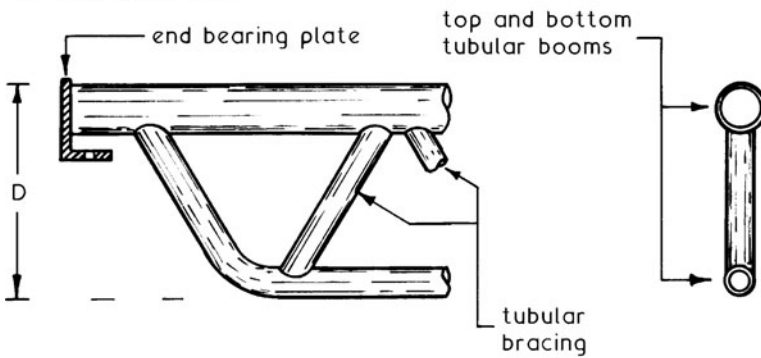

## DOWELLED LATTICE

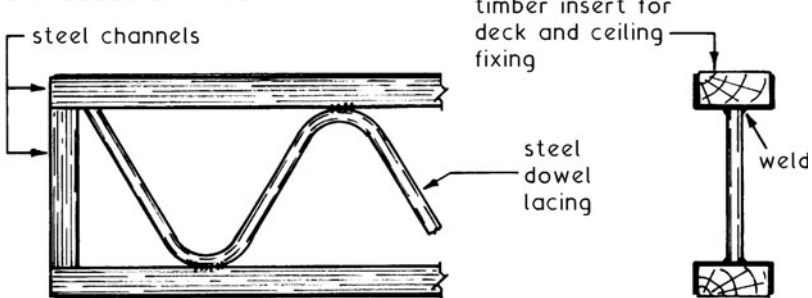

NB. Span potential for lattice beams is approximately  $24 \times D$ .

Structural Steelwork Connections ~ these are either workshop or site connections according to where the fabrication takes place. Most site connections are bolted whereas workshop connections are very often carried out by welding. The design of structural steelwork members and their connections is the province of the structural engineer who selects the type and number of bolts or the size and length of weld to be used according to the connection strength to be achieved.

Typical Connection Examples ~

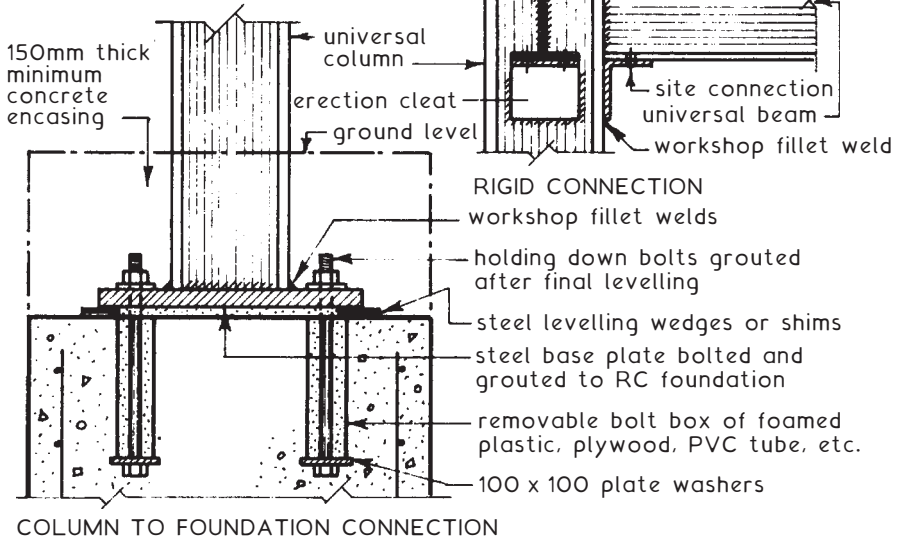
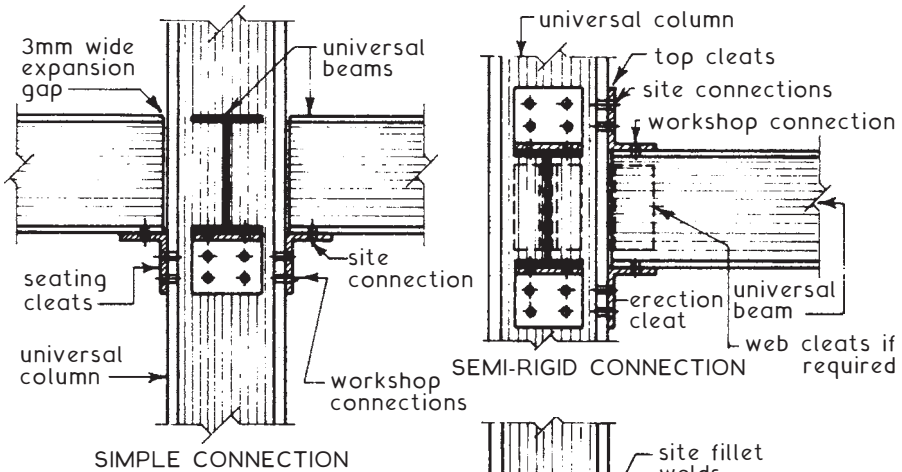

Typical Connection Examples ~

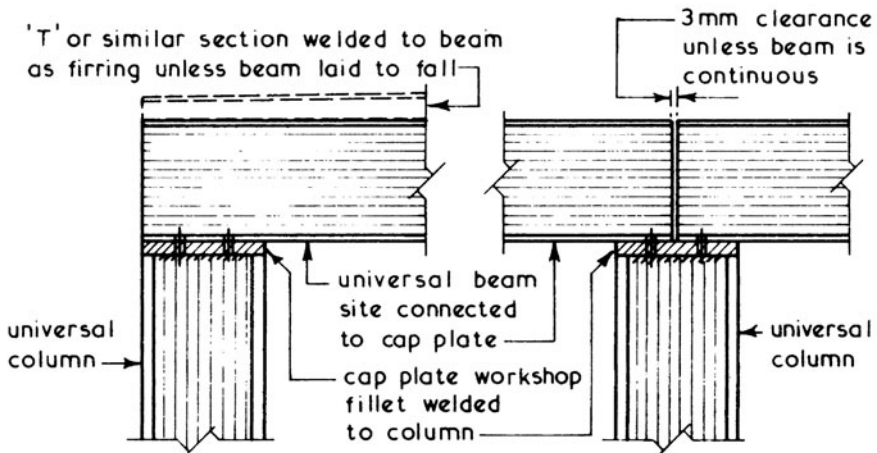

TOP BEAM BEARING CONNECTIONS

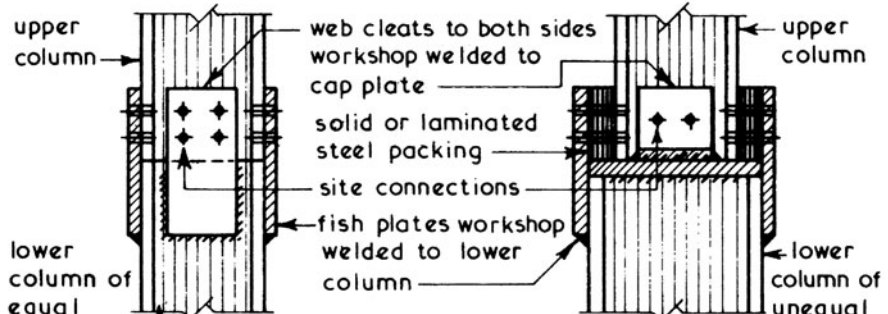

COLUMN TO COLUMN CONNECTIONS

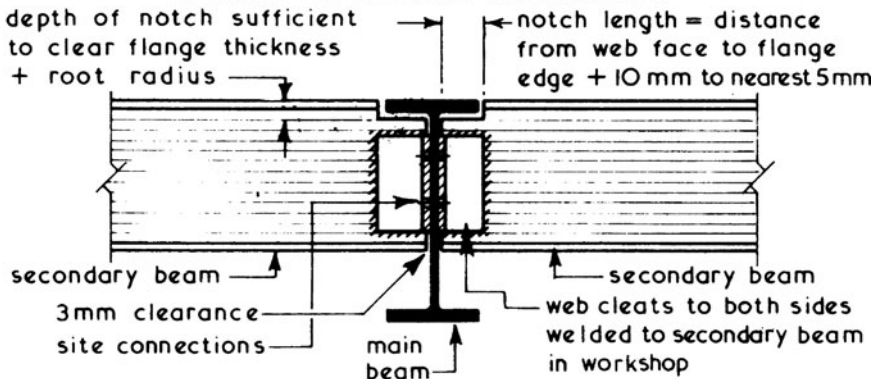

BEAM TO BEAM CONNECTION

NB. All holes for bolted connections must be made from backmarking the outer surface of the section(s) involved. For actual positions see structural steelwork manuals.

Types ~

Slab or bloom base.

Gusset base.

Steel grillage (see page 263).

The type selected will depend on the load carried by the column and the distribution area of the base plate. The cross sectional area of a UC concentrates the load into a relatively small part of the base plate. Therefore to resist bending and shear, the base must be designed to resist the column loads and transfer them onto the pad foundation below.

SLAB or BLOOM BASE

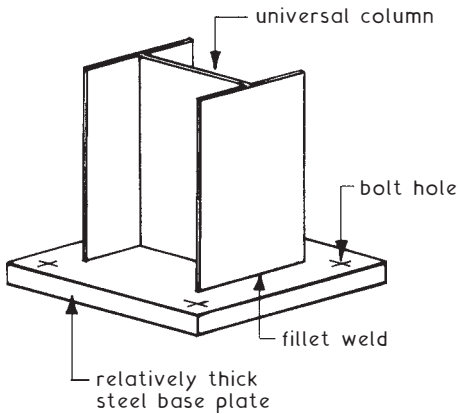

SLAB BASE WITH ANGLE CLEATS

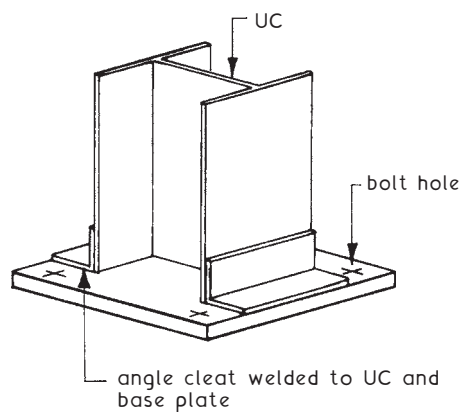

GUSSET BASE

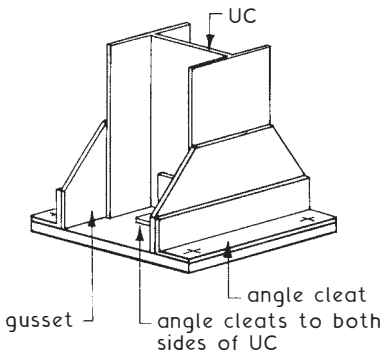

BOLT BOX

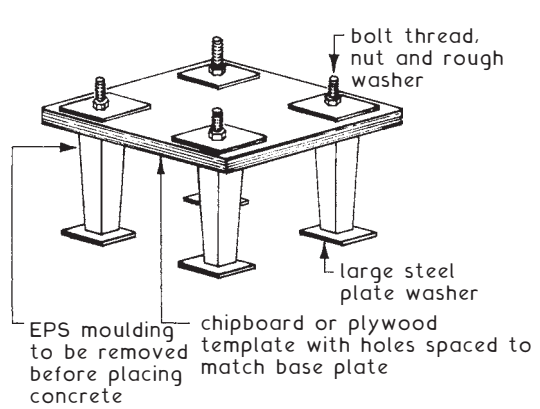

Bolt Box ~ a template used to accurately locate column holding down bolts into wet concrete. EPS or plastic tubes provide space around the bolts when the concrete has set. The bolts can then be moved slightly to aid alignment with the column base.



## Structural Steelwork – Welded Connections

Welding is used to prefabricate the sub-assembly of steel frame components in the workshop, prior to delivery to site where the convenience of bolted joints will be preferred.

Oxygen and acetylene (oxy-acetylene) gas welding equipment may be used to fuse together light steel sections, but otherwise it is limited to cutting profiles of the type shown on page 631. The electric arc process is preferred as it is more effective and efficient. This technique applies an expendable steel electrode to fuse parts together by high amperage current. The current potential and electrode size can be easily changed to suit the thickness of metal.

Overlapping of sections permits the convenience of fillet welds, but if the overlap is obstructive or continuity and direct transfer of loads is necessary, a butt weld will be specified. To ensure adequate weld penetration with a butt weld, the edges of the parent metal should be ground to produce an edge chamfer. For very large sections, both sides of the material should be chamfered to allow for double welds.

### BUTT WELD

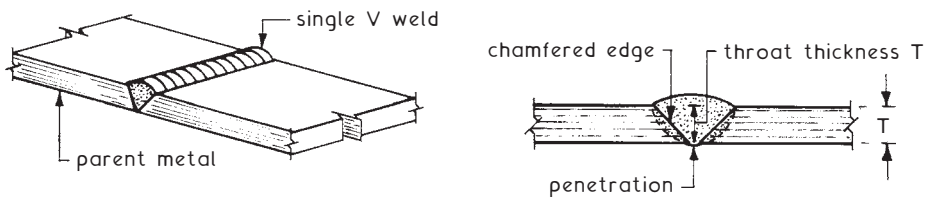

NB. For greater thicknesses of parent metal, both sides are chamfered in preparation for a double weld.

### FILLET WELD

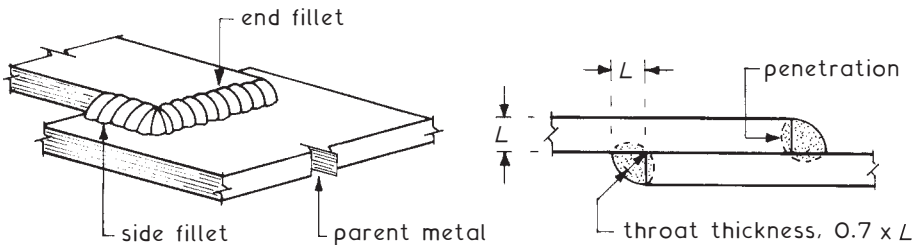

Ref. BS EN 1011-1 and 2: Welding. Recommendations for welding of metallic materials.

Bolts are the preferred method for site assembly of framed building components, although rivets have been popular in the past and will be found when working on existing buildings. Cold driven and 'pop' rivets may be used for factory assembly of light steel frames such as stud walling, but the traditional process of hot riveting structural steel both in the workshop and on site has largely been superseded for safety reasons and the convenience of other practices.

### Types of Bolt:

1. Black Bolts ~ the least expensive and least precise type of bolt, produced by forging with only the bolt and nut threads machined. Clearance between the bolt shank and bolt hole is about 2mm, a tolerance that provides for ease of assembly. However, this imprecision limits the application of these bolts to direct bearing of components onto support brackets or seating cleats.
2. Bright Bolts ~ also known as turned and fitted bolts. These are machined under the bolt head and along the shank to produce a close fit of 0.5mm hole clearance. They are specified where accuracy is paramount.
3. High Strength Friction Grip Bolts ~ also known as torque bolts as they are tightened to a predetermined shank tension by a torque-controlled wrench. This procedure produces a clamping force that transfers the connection by friction between components and not by shear or bearing on the bolts. These bolts are manufactured from high-yield steel. The number of bolts used to make a connection is less than otherwise required.

### Refs.:

BS 4190: ISO metric black hexagon bolts, screws and nuts. Specification.

BS 3692: ISO metric precision hexagon bolts, screws and nuts. Specification.

BS 4395 (2 parts): Specification for high strength friction grip bolts and associated nuts and washers for structural engineering.

BS EN 14399 (9 parts): High strength structural bolting assemblies for preloading.

# Structural Steelwork – Fire Protection

Fire Resistance of Structural Steelwork ~ although steel is a non-combustible material with negligible surface spread of flame properties it does not behave very well under fire conditions. During the initial stages of a fire the steel will actually gain in strength but this reduces to normal at a steel temperature range of 250 to 400°C and continues to decrease until the steel temperature reaches 550°C when it has lost most of its strength. Since the temperature rise during a fire is rapid, most structural steelwork will need protection to give it a specific degree of fire resistance in terms of time. Part B of the Building Regulations sets out the minimum requirements related to building usage and size. BRE Report 128 'Guidelines for the construction of fire resisting structural elements' gives acceptable methods.

Typical Examples for 120 minutes' Fire Resistance ~

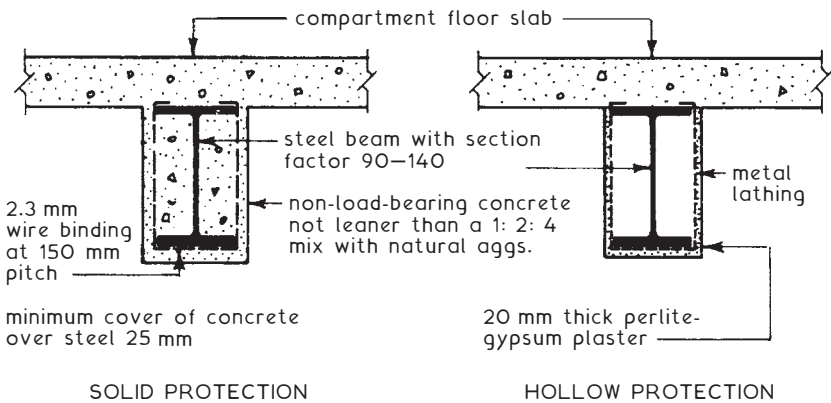
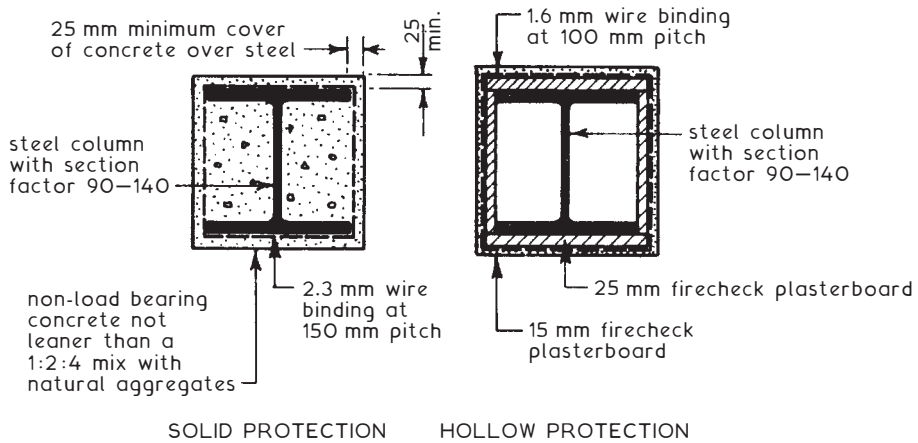

NB. For section factor calculations see next page.

Section Factors – these are criteria found in tabulated fire protection data such as the Loss Prevention Certification Board's Standards. These factors can be used to establish the minimum thickness or cover of protective material for structural sections. This interpretation is usually preferred by buildings insurance companies, as it often provides a standard in excess of the Building Regulations. Section factors are categorised: <90, 90-140 and >140. They can be calculated by the following formula:

$$\text{Section Factor} = H_p/A \text{ (m}^{-1}\text{)}$$

$H_p$  = Perimeter of section exposed to fire (m)

$A$  = Cross sectional area of steel (m<sup>2</sup>) [see BS 4-1 or Structural Steel Tables]

Examples:

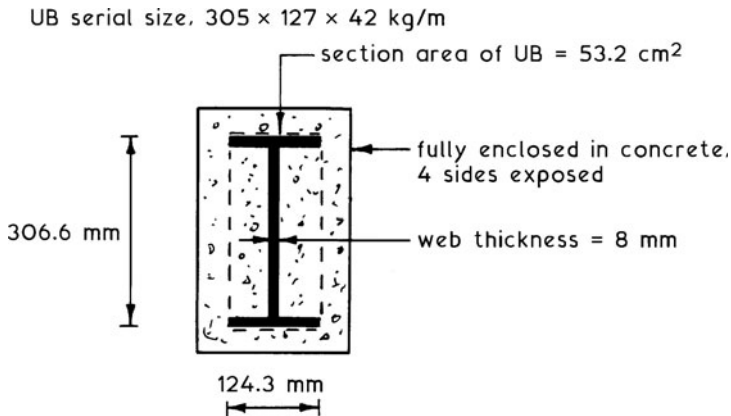

$$H_p = (2 \times 124.3) + (2 \times 306.6) + 2(124.3 - 8) = 1.0944 \text{ m}$$

$$A = 53.2 \text{ cm}^2 \text{ or } 0.00532 \text{ m}^2$$

$$\text{Section Factor, } H_p/A = 1.0944/0.00532 = 205$$

As beam above, but three sides only exposed

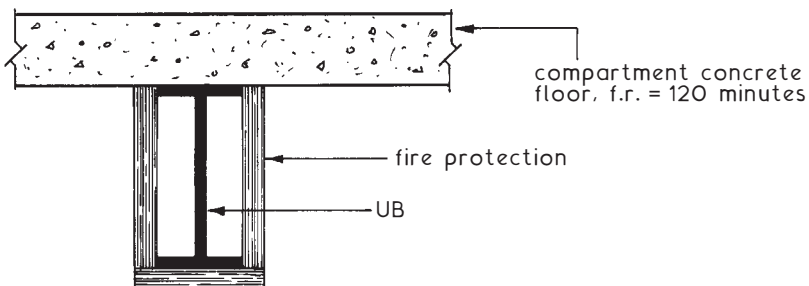

$$H_p = 124.3 + (2 \times 306.6) + 2(124.3 - 8) = 0.9701 \text{ m}$$

$$A = 53.2 \text{ cm}^2 \text{ or } 0.00532 \text{ m}^2$$

$$\text{Section Factor, } H_p/A = 0.9701/0.00532 = 182$$

## Structural Steelwork – Beam Design (1)

Refs.: BS 4-1: Structural steel sections. Specification for hot rolled sections.

BS EN 1993-1: Design of steel structures.

Simple beam design (Bending)

Formula:

$$Z = \frac{M}{f}$$

where:  $Z$  = section or elastic modulus (BS 4-1)

$M$  = moment of resistance  $\geq$  or = max. bending moment

$f$  = fibre stress of the material (normally  $165 \text{ N/mm}^2$  for rolled steel sections)

In simple situations the bending moment can be calculated:

(a) Point loads

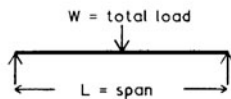

$$BM = \frac{WL}{4}$$

(b) Distributed loads

e.g.

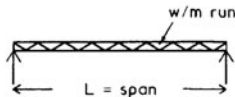

$$BM = \frac{wL^2}{8} \text{ or } \frac{WL}{8}$$

where  $W = w \times L$

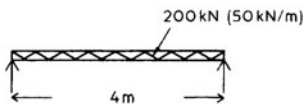

$$BM = \frac{wL^2}{8} = \frac{50 \times 4^2}{8} = 100 \text{ kNm}$$

$$Z = \frac{M}{f} = \frac{100 \times 10^6}{165} = 606 \text{ cm}^3$$

From structural design tables, e.g. BS 4-1, a Universal Beam  $305 \times 127 \times 48 \text{ kg/m}$  with section modulus ( $Z$ ) of  $612.4 \text{ cm}^3$  about the x-x axis, can be seen to satisfy the calculated  $606 \text{ cm}^3$ .

NB. Total load in kN can be established by summing the weight of materials – see pages 38 to 39: The total weight of materials multiplied by gravity; i.e.  $\text{kg} \times 9.81 = \text{Newtons}$ .

This must be added to any imposed loading:

People and furniture =  $1.5 \text{ kN/m}^2$

Snow on roofs  $< 30^\circ$  pitch =  $1.5 \text{ kN/m}^2$

Snow on roofs  $> 30^\circ$  pitch =  $0.75 \text{ kN/m}^2$

Simple beam design (shear)

From the previous example, the section profile is:

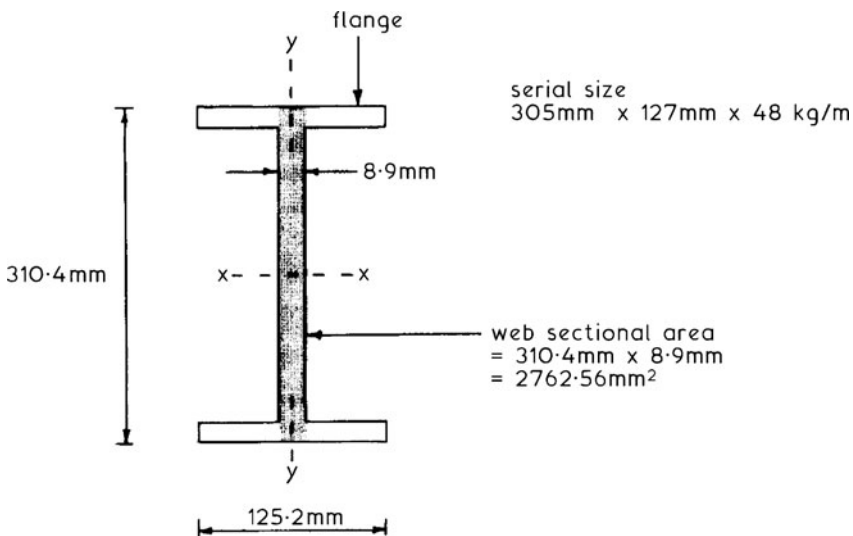

Maximum shear force normally occurs at the support points, i.e. near the end of the beam. Calculation is made of the average stress value on the web sectional area.

Using the example of 200 kN load distributed over the beam, the maximum shear force at each end support will be 100 kN.

$$\begin{aligned}
 \text{Therefore, the average shear stress} &= \frac{\text{shear force}}{\text{web sectional area}} \\
 &= \frac{100 \times 10^3}{2762.56} \\
 &= 36.20 \text{ N/mm}^2
 \end{aligned}$$

Grade S275 steel has an allowable shear stress in the web of 110 N/mm<sup>2</sup>. Therefore the example section of serial size: 305 mm x 127 mm x 48 kg/m with only 36.20 N/mm<sup>2</sup> calculated average shear stress is more than capable of resisting the applied forces.

Grade S275 steel has a characteristic yield stress of 275 N/mm<sup>2</sup> in sections up to 40 mm thickness. This grade is adequate for most applications, but the more expensive grade S355 steel is available for higher stress situations.

Ref. BS EN 10025: Hot rolled products of structural steels.

## Structural Steelwork – Beam Design (3)

### Simple beam design (deflection)

The deflection due to loading, other than the weight of the structure, should not exceed 1/360 of the span.

The formula to determine the extent of deflection varies, depending on:

#### (a) Point loading

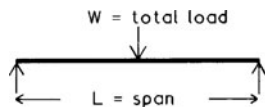

$$\text{Deflection} = \frac{WL^3}{48EI}$$

#### (b) Uniformly distributed loading

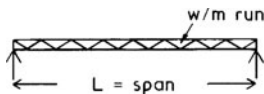

$$\text{Deflection} = \frac{5WL^3}{384EI}$$

where: W = load in kN

L = span in cm

E = Young's modulus of elasticity (typically 21,000 kN/cm<sup>2</sup> for steel)

I = 2nd moment of area about the x-x axis (see BS 4-1)

Using the example of 200 kN uniformly distributed over a 4 m span:

$$\text{Deflection} = \frac{5WL^3}{384EI} = \frac{5 \times 200 \times 4^3 \times 100^3}{384 \times 21000 \times 9504} = 0.835 \text{ cm}$$

Permissible deflection is 1/360 of 4 m = 11.1 mm or 1.1 cm.

Therefore actual deflection of 8.35 mm or 0.835 cm is acceptable.

Ref. BS EN 1993-1: Design of steel structures.

## Summary of Properties Applicable to Loaded Beams ~

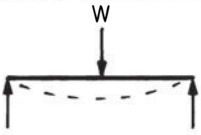
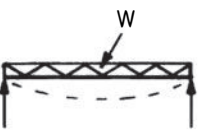
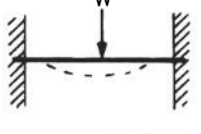
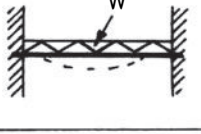
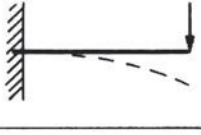
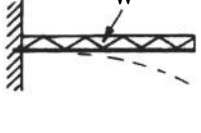
Beam type	Load type	Maximum shear	Maximum BM	Maximum deflection	Arrangement over span L
Simply supported	Central point load W	$\frac{W}{2}$	$\frac{WL}{4}$	$\frac{WL^3}{48EI}$	
Simply supported	UDL W	$\frac{W}{2}$	$\frac{WL}{8}$	$\frac{5WL^3}{384EI}$	
Ends fixed	Central point load W	$\frac{W}{2}$	$\frac{WL}{8}$ * $-\frac{WL}{8}$ •	$\frac{WL^3}{192EI}$	
Ends fixed	UDL W	$\frac{W}{2}$	$-\frac{WL}{12}$ * $\frac{WL}{24}$ •	$\frac{WL^3}{384EI}$	
Cantilever	Point load W at end	W	-WL	$\frac{WL^3}{3EI}$	
Cantilever	UDL W	W	$-\frac{WL}{2}$	$\frac{WL^3}{8EI}$	

\* At supports

• At mid-span

Note: Where a beam of constant properties, i.e. size, section modulus and 2<sup>nd</sup>. moment of area is used with the same type of end support to carry the same load:

- the bending moment will increase linearly with span, e.g. a doubling of the span doubles the bending moment.
- the deflection will increase by the span (L) cubed, e.g. doubling the span increases the deflection by eight times (2)<sup>3</sup>.



## Structural Steelwork – Column Design

### Simple column design

Steel columns or stanchions have a tendency to buckle or bend under extreme loading. This can be attributed to:

- (a) length
  - (b) cross sectional area
  - (c) method of end fixing, and
  - (d) the shape of section.
- (b) and (d) are incorporated into a geometric property of section, known as the radius of gyration ( $r$ ). It can be calculated:

$$r = \sqrt{\frac{I}{A}}$$

where:  $I$  = 2nd moment of area

$A$  = cross-sectional area

Note:  $r$ ,  $I$  and  $A$  are all listed in steel design tables, e.g. BS 4-1.

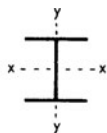

The radius of gyration about the y-y axis is used for calculation, as this is normally the weaker axis.

The length of a column will affect its slenderness ratio and potential to buckle. This length is calculated as an effective length relative to the method of fixing each end. Examples of position and direction fixing are shown on the next page, e.g. A Universal Column 203 mm × 203 mm × 46 kg/m, 10 m long, position and direction fixed both ends. Determine the maximum axial loading.

Effective length ( $l$ ) = 0.7 × 10 m = 7 m

( $r$ ) from BS 4-1 = 51.1 mm

$$\text{Slenderness ratio} = \frac{l}{r} = \frac{7 \times 10^3}{51.1} = 137$$

From structural steel design tables the maximum allowable stress for grade S275 steel with slenderness ratio of 137 is 48 N/mm<sup>2</sup>

Cross sectional area of stanchion (UC) = 5880 mm<sup>2</sup> (BS 4-1)

$$\text{The total axial load} = \frac{48 \times 5880}{10^3} = 283 \text{ kN (approx. 28 tonnes)}$$

## Structural Steelwork – Effective Column Length

The tendency for a column to buckle depends on its slenderness as determined by the ratio of its effective length to the radius of gyration about the weaker axis.

Effective lengths of columns and struts in compression ~

End conditions	Effective length relative to actual length
Restrained both ends in position and direction	0.70
Restrained both ends in position with one end in direction	0.85
Restrained both ends in position but not in direction	1.00
Restrained one end in position and direction. The other end restrained in direction only	1.50
Restrained one end in position and direction. The other end unrestrained	2.00

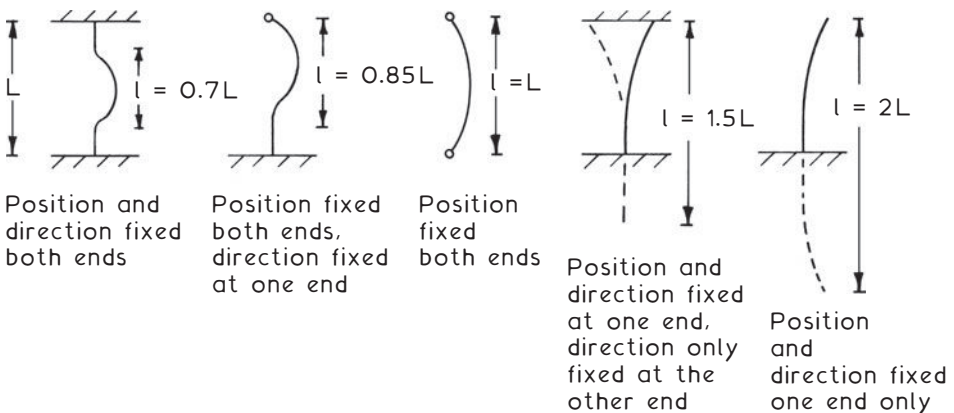

Position and direction fixed is location at specific points by beams or other means of retention. Position fixed only means hinged or pinned.

The effective lengths shown apply to the simplest of structures, for example, single storey buildings. Where variations occur such as cross braced support to columns, corrective factors should be applied to the effective length calculations. Guidance is available in BS EN 1993-1: Design of steel structures.

## Portal Frames

Portal Frames ~ these can be defined as two-dimensional rigid frames which have the basic characteristic of a rigid joint between the column and the beam. The main objective of this form of design is to reduce the bending moment in the beam thus allowing the frame to act as one structural unit. The transfer of stresses from the beam to the column can result in a rotational movement at the foundation which can be overcome by the introduction of a pin or hinge joint. The pin or hinge will allow free rotation to take place at the point of fixity whilst transmitting both load and shear from one member to another. In practice a true 'pivot' is not always required but there must be enough movement to ensure that the rigidity at the point of connection is low enough to overcome the tendency of rotational movement.

### Typical Single Storey Portal Frame Formats ~

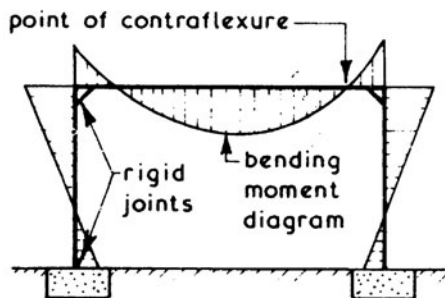

#### FIXED or RIGID PORTAL FRAME:

all joints or connections are rigid giving lower bending moments than other formats. Used for small to medium span frames where moments at foundations are not excessive.

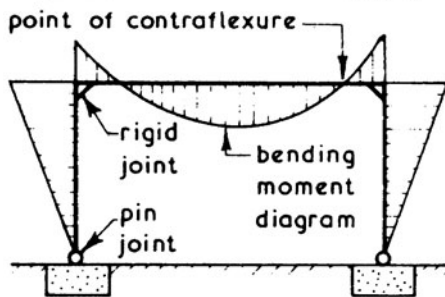

#### TWO-PIN PORTAL FRAME:

pin joints or hinges used at foundation connections to eliminate tendency of base to rotate. Used where high base moments and weak ground are encountered.

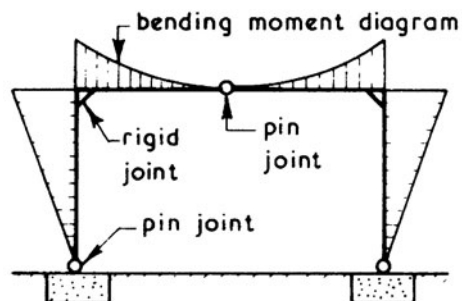

#### THREE-PIN PORTAL FRAME:

pin joints or hinges used at foundation connections and at centre of beam which reduces bending moment in beam but increases deflection. Used as an alternative to a two-pin frame.

Typical Precast Concrete Portal Frame Details ~

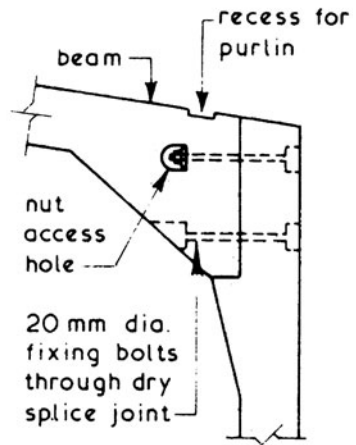
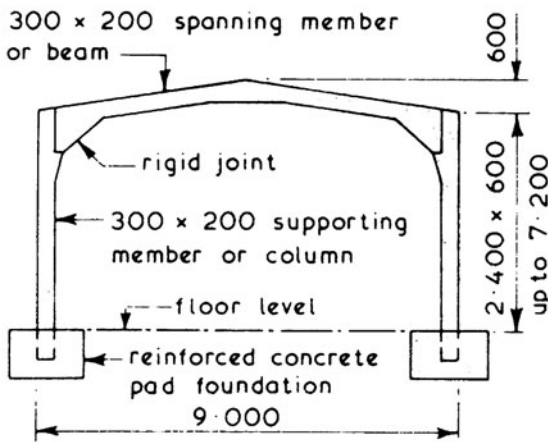

TYPICAL SINGLE SPAN PORTAL FRAME  
 (frame spacing 4.500 to 6.000%)

TYPICAL BEAM TO COLUMN JOINT

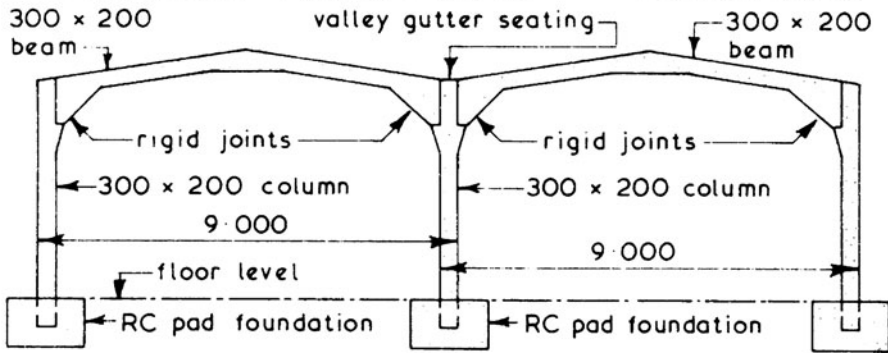

TYPICAL MULTI-SPAN PORTAL FRAME  
 (frame spacing 4.500 to 6.000%)

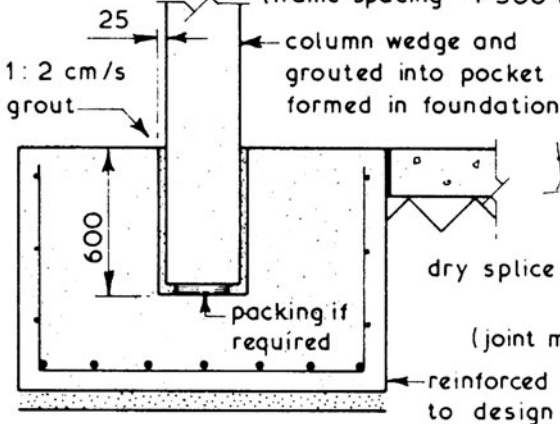

TYPICAL FOUNDATION DETAILS

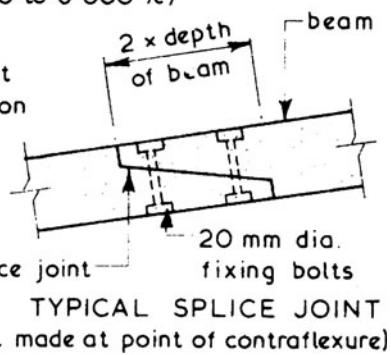

Typical Precast Concrete Portal Frame Hinge Details ~

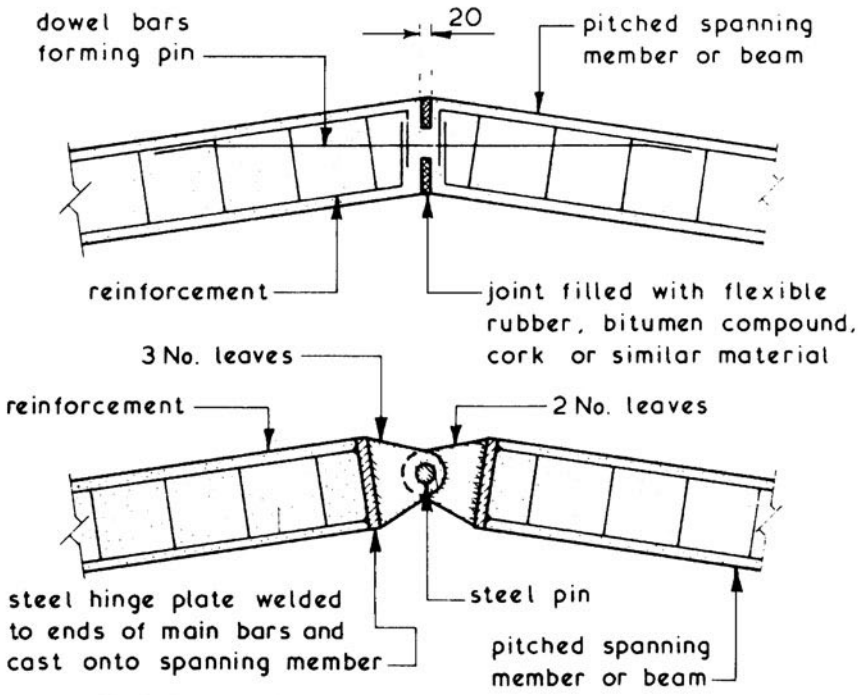

TYPICAL APEX OR CROWN HINGE DETAILS

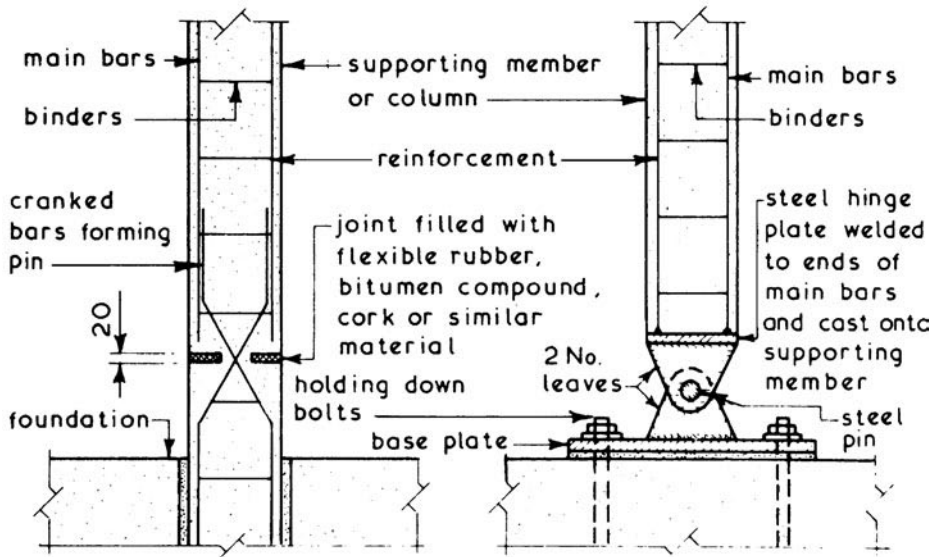

TYPICAL FOUNDATION CONNECTION HINGE DETAILS

Typical Steel Portal Frame Details ~

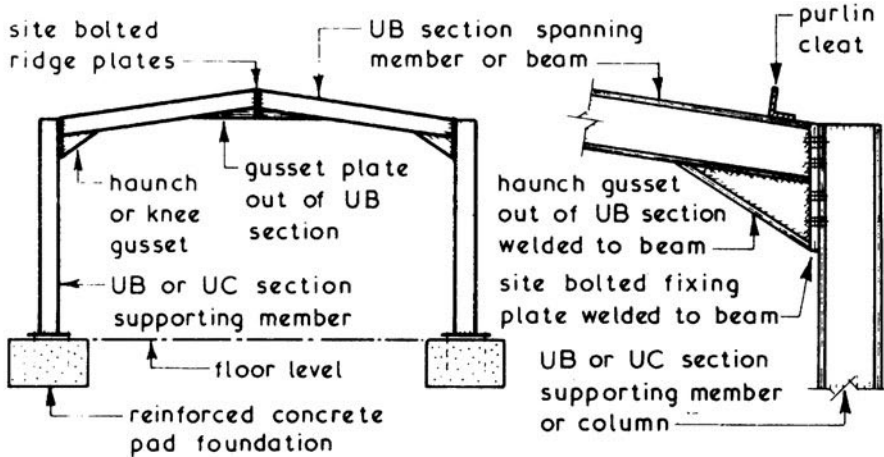

TYPICAL SINGLE SPAN PORTAL FRAME  
(frame spacing 4.500 to 6.000 %)

TYPICAL BEAM  
TO COLUMN JOINT

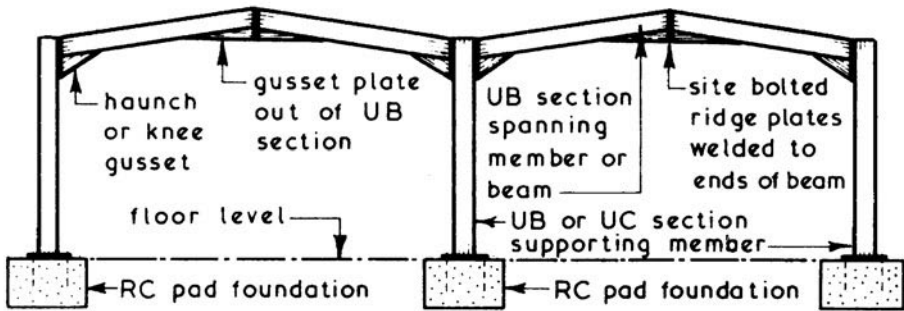

TYPICAL MULTI-SPAN PORTAL FRAME  
(frame spacing 4.500 to 6.000%)

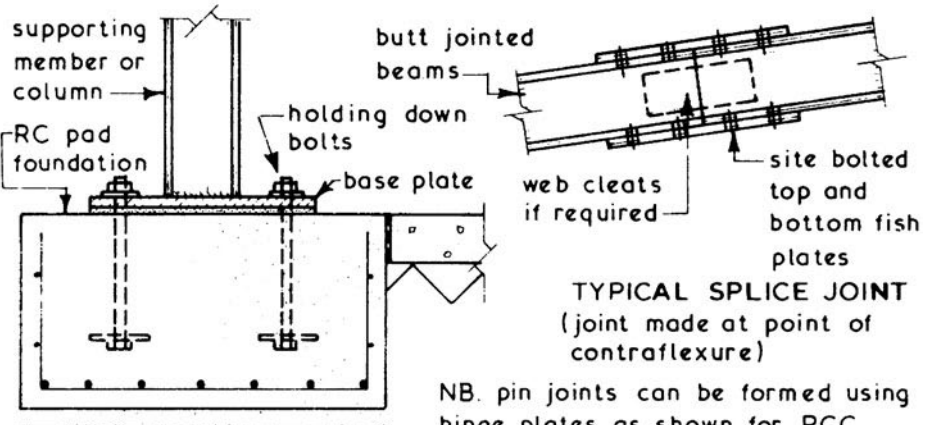

FOUNDATION DETAILS

TYPICAL SPLICE JOINT  
(joint made at point of contraflexure)

NB. pin joints can be formed using hinge plates as shown for PCC frames on previous page.

# Portal Frames – Timber

Plywood Faced Lattice ~ framework of planed standard softwood sections with a plywood facing to both sides. A lightweight structure with high span to weight ratio. Spans to about 9m are possible with modest size timber members, providing economical construction for halls, community centres, etc. Based on the principle of a box beam comprising flanges or chords to resist bending, web stiffeners to control buckling and plywood facing to resist shear and bending as well as enhancing appearance.

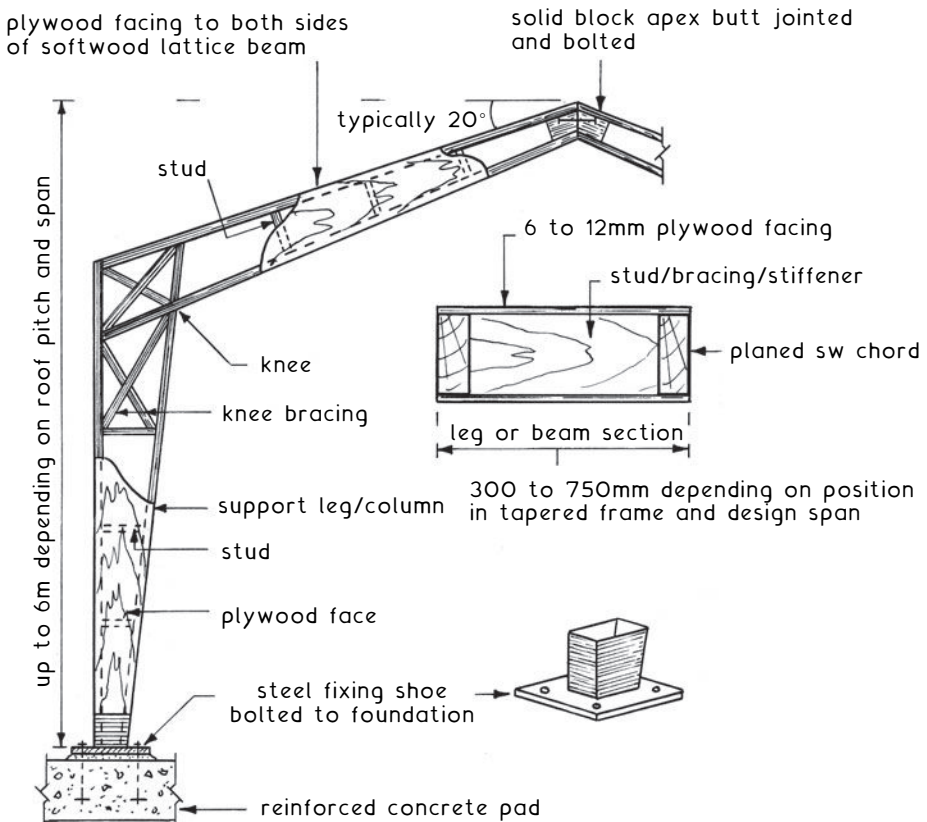

Laminated Timber ~ sometimes called 'Gluelam' and is the process of building up beams, ribs, arches, portal frames and other structural units by gluing together layers of timber boards so that the direction of the grain of each board runs parallel with the longitudinal axis of the member being fabricated.

Laminates ~ these are the layers of board and may be jointed in width and length.

Joints ~

Width - joints in consecutive layers should lap twice the board thickness or one-quarter of its width whichever is the greater.

Length - scarf and finger joints can be used. Scarf joints should have a minimum slope of 1 in 12 but this can be steeper (say 1 in 6) in the compression edge of a beam:

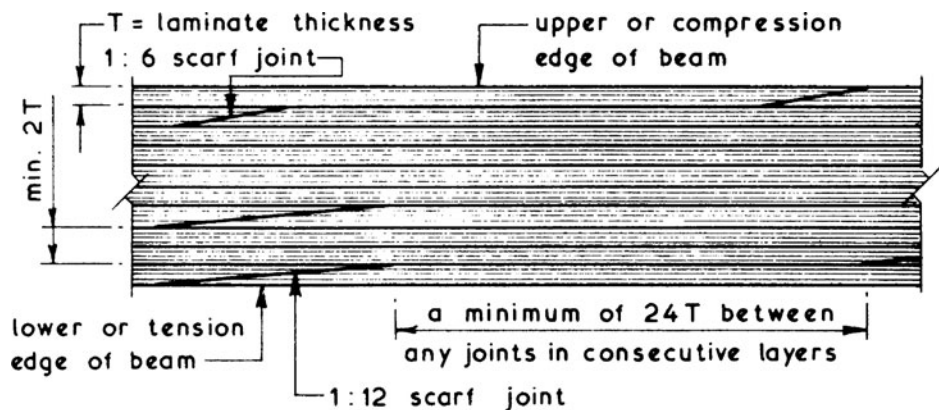

Finger joints are more economical in the use of timber than the scarf joints

laminated timber beam

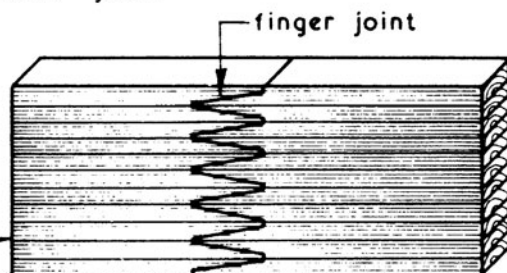

Moisture Content ~ timber should have a moisture content equal to that which the member will reach in service and this is known as its equilibrium moisture content; for most buildings this will be between 11 and 15%. Generally at the time of gluing timber should not exceed  $15 \pm 3\%$  in moisture content.



# Laminated Timber

Vertical Laminations ~ not often used for structural laminated timber members and is unsatisfactory for curved members.

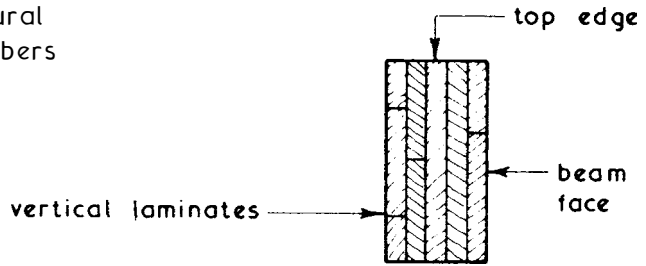

Horizontal Laminations ~ most popular method for all types of laminated timber members. The stress diagrams below show that laminates near the upper edge are subject to a compressive stress whilst those near the lower edge to a tensile stress and those near the neutral axis are subject to shear stress.

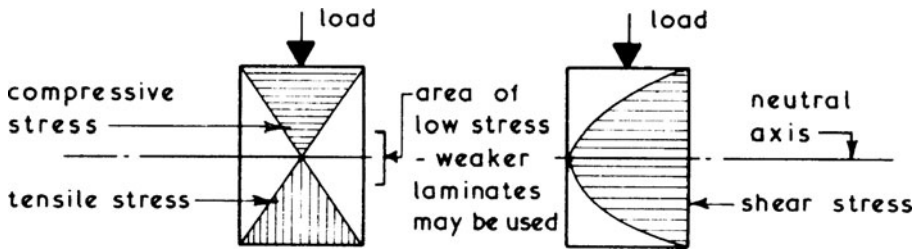

Flat sawn timber shrinks twice as much as quarter sawn timber; therefore flat and quarter sawn timbers should not be mixed in the same member since the different shrinkage rates will cause unacceptable stresses to occur on the glue lines.

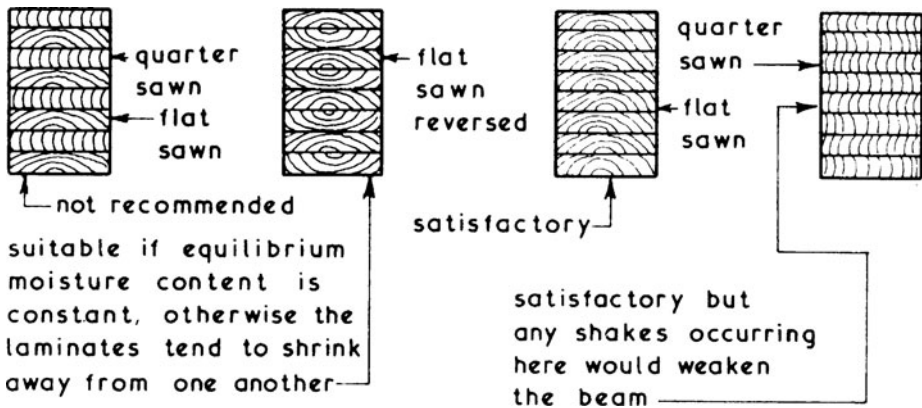

Planing ~ before gluing, laminates should be planed so that the depth of the planer cutter marks are not greater than 0.025mm.

Gluing ~ this should be carried out within 48 hours of the planing operation to reduce the risk of the planed surfaces becoming contaminated or case hardened (for suitable adhesives see next page). Just before gluing up the laminates they should be checked for 'cupping'. The amount of cupping allowed depends upon the thickness and width of the laminates and has a range of 0.75 mm to 1.5 mm.

Laminate Thickness ~ no laminate should be more than 50 mm thick since seasoning up to this thickness can be carried out economically and there is less chance of any individual laminate having excessive cross-grain strength.

Straight Members - laminate thickness is determined by the depth of the member, there must be enough layers to allow the end joints (i.e. scarf or finger joints - see page 651) to be properly staggered.

Curved Members - laminate thickness is determined by the radius to which the laminate is to be bent and the species together with the quality of the timber being used. Generally the maximum laminate thickness should be  $1/150$  of the sharpest curve radius although with some softwoods  $1/100$  may be used.

Typical Laminated Timber Curved Member ~

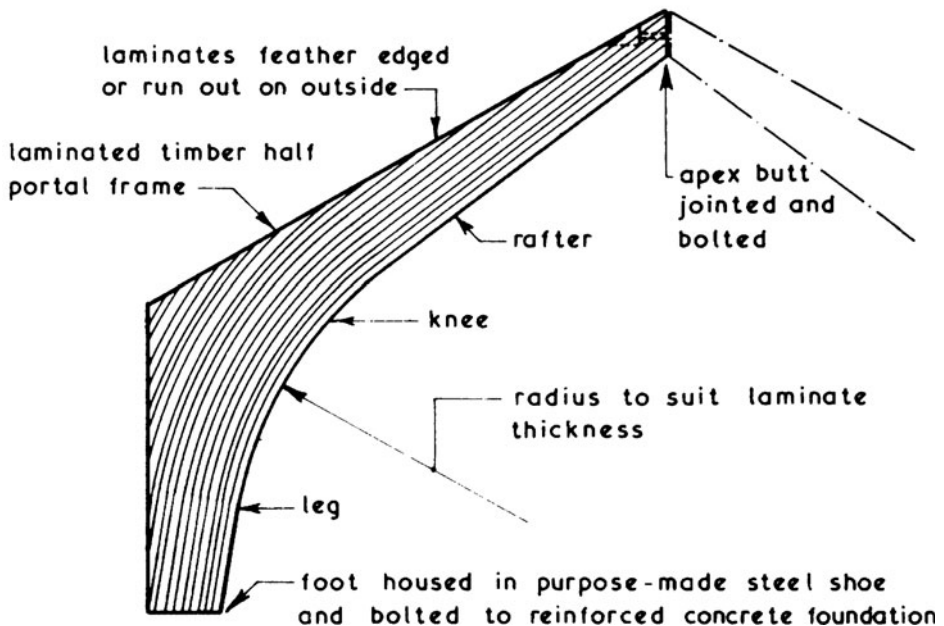

## Laminated Timber

Adhesives ~ although timber laminates are carefully machined, the minimum of cupping permitted and efficient cramping methods employed mean it is not always possible to obtain really tight joints between the laminates. One of the important properties of the adhesive is therefore that it should be gap filling. The maximum permissible gap is 1.25 mm.

There are four adhesives suitable for laminated timber work which have the necessary gap filling property and they are:

1. Casein - the protein in milk, extracted by coagulation and precipitation. It is a cold setting adhesive in the form of a powder which is mixed with water, it has a tendency to stain timber and is only suitable for members used in dry conditions of service.
2. Urea Formaldehyde - this is a cold setting resin glue formulated to MR/GF (moisture resistant/gap filling). Although moisture resistant it is not suitable for prolonged exposure in wet conditions and there is a tendency for the glue to lose its strength in temperatures above 40°C such as when exposed to direct sunlight. The use of this adhesive is usually confined to members used in dry, unexposed conditions of service. This adhesive will set under temperatures down to 10°C.
3. Resorcinol Formaldehyde - this is a cold setting glue formulated to WBP/GF (weather and boilproof/gap filling). It is suitable for members used in external situations but is relatively expensive. This adhesive will set under temperatures down to 15°C and does not lose its strength at high temperatures.
4. Phenol Formaldehyde - this is a similar glue to resorcinol formaldehyde but is a warm setting adhesive requiring a temperature of above 86°C in order to set. Phenol/resorcinol formaldehyde is an alternative, having similar properties to but less expensive than resorcinol formaldehyde. PRF needs a setting temperature of at least 23°C.

Preservative Treatment - this can be employed if required, provided that the pressure impregnated preservative used is selected with regard to the adhesive being employed. See also page 545.

Ref. BS EN 301: Adhesives, phenolic and aminoplastic, for load-bearing timber structures. Classification and performance requirements.

Composite Beams ~ stock sizes of structural softwood have sectional limitations of about 225 mm and corresponding span potential in the region of 6 m. At this distance, even modest loadings could interpose with the maximum recommended deflection of  $0.003 \times \text{span}$ .

Fabricated softwood box, lattice and plywood beams are an economic consideration for medium spans. They are produced with adequate depth to resist deflection and with sufficient strength for spans into double figures. The high strength to weight ratio and simple construction provides advantages in many situations otherwise associated with steel or reinforced concrete, e.g. frames, trusses, beams and purlins in gymnasia, workshops, garages, churches, shops, etc. They are also appropriate as purlins in loft conversion.

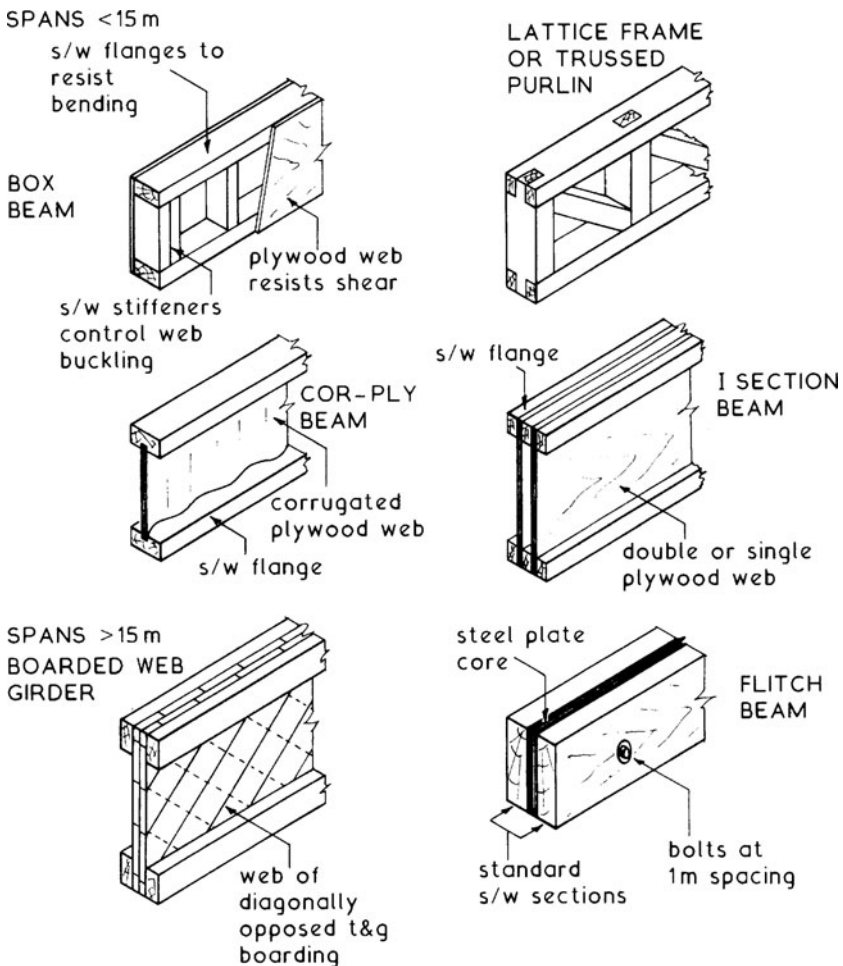

## Parallel Strand Beam (PSB)

PSB ~ otherwise known as a parallam beam. Fabricated from long strands of softwood timber bonded with a phenol-formaldehyde adhesive along the length of the beam to produce a structural section of greater strength than natural timber of equivalent section. Used for beams, lintels, structural framing and trimmer sections around floor openings in spans up to 20 m. Can also be used vertically as columns.

Standard sizes ~ range from 200 × 45 mm up to 406 × 178 mm.

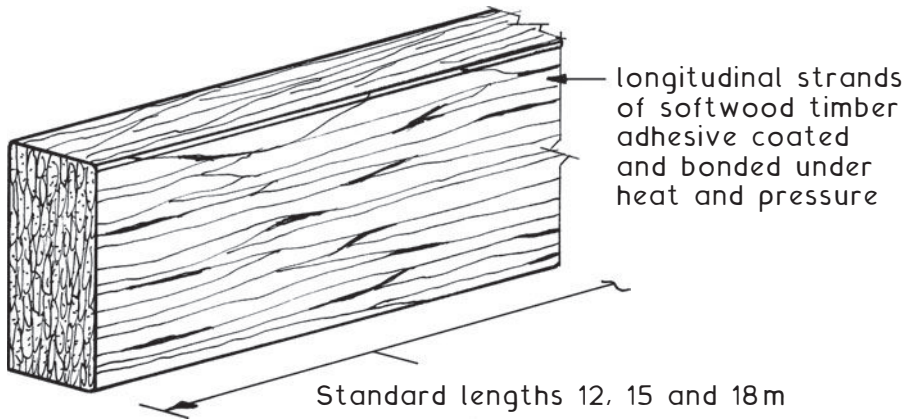

Typical grade stresses [N/mm<sup>2</sup>] (compare with sw timber, page 142) ~

Bending parallel to grain	16.8
Tension parallel to grain	14.8
Compression parallel to grain	15.1
Compression perpendicular to grain	3.6
Shear parallel to grain	2.2
Modulus of elasticity (mean)	12750
Average density	740 kg/m <sup>3</sup>

Variation ~ for spans in excess of 20 m or for high loads, a fitch beam as shown on the previous page can be made by bolting a steel plate (typically 10 or 12 mm) between two PSBs.

Ref. BBA Agrément Certificate No. 92/2813.

Composite Joist ~ a type of lattice frame, constructed from a pair of parallel and opposing stress graded softwood timber flanges, separated and jointed with a web of V-shaped galvanised steel plate connectors. Manufacture is off site in a factory quality-controlled situation. Here, joists can be made in standard or specific lengths to order. Depending on loading, spans to about 8 m are possible at joist spacing up to 600 mm.

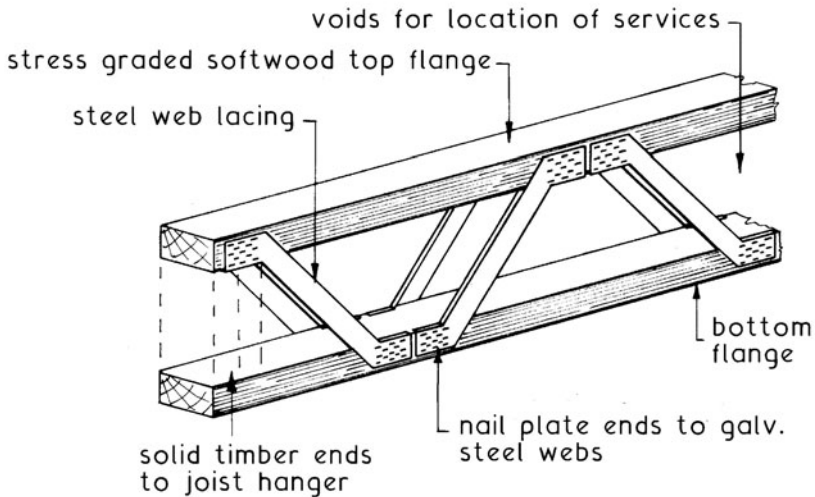
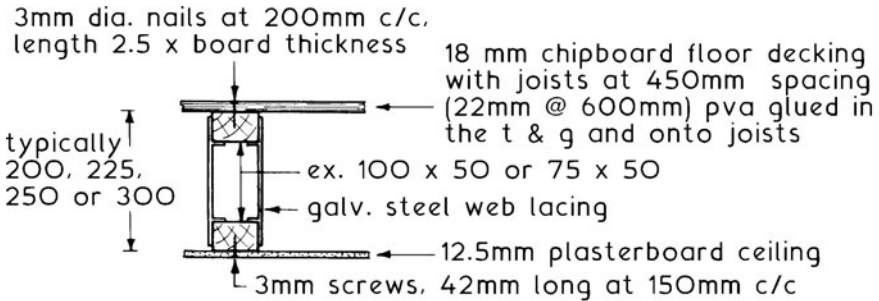

End bearing on inner leaf of cavity wall, silicone sealed to maintain airtightness. Alternatively lateral restraint-type joist hanger support or intermediate support from a steel beam.

Advantages over solid timber joists:

- Large span to depth ratio.
- High strength to weight ratio.
- Alternative applications, including roof members, purlins, etc.
- Generous space for services without holing or notching.
- Minimal movement and shrinkage.
- Wide flanges provide large bearing area for decking and ceiling board.

## Structures for Height

Otherwise known as tall, high rise or multi-storey buildings. Designed as an economic necessity where urban spread is prevented due to planning development constraints, e.g. green belt restrictions and as a response to high density living requirements in towns and cities. Tall buildings are also constructed to present an image of corporate status.

Building Types ~ residential apartments, hotels and office blocks.

Material Considerations ~ until the late 19th century when steel became commercially available, buildings of several storeys were constructed of brick masonry. By modern standards for height, with the exception of a modest rise to about four or five storeys, load-bearing masonry is uneconomic due to the necessary width of the lower walls to carry the superstructural loads. Therefore, framed structures of steel reinforced concrete or steel hot rolled sections are used, whereby the wall is infilling only, being relieved of any load bearing function except that of its own weight. The choice between reinforced concrete or steel for the framing is an economic decision dependent on the availability and cost of materials and appropriately qualified and experienced work force.

Design Constraints ~ the relationship between the superstructure, its foundations and the bearing capacity of the subsoil is the most important consideration. In particular, loading from vertical or gravitational forces in addition to exposure to horizontal or lateral wind forces and possibly ground movement from earthquakes.

Other Significant Design Factors ~

- Internal movement/circulation of occupants. Up to 20% of the floor area may be required to provide for vertical access in the form of stairs, lifts and escalators.
- Up to 15% of the volume of a building may be required to accommodate the services, i.e. plumbing, sanitation, drainage, ventilation, air conditioning, electrical cabling, etc. This is usually contained within suspended ceilings and raised floors.
- Occupancy type, building function and purpose will influence internal layout and structural floor load.
- External accessibility, often constrained in city and town centres. Movement must be factored in as this will affect the construction programme and subsequent efficient function of a building.

Traditional Rigid Frame ~ the structure is designed with rigidly connected welded and bolted joints between columns and beams. These joints sustain bending and provide resistance to lateral/horizontal forces. Columns are positioned quite closely and internal columns may impose to some extent on the design of the interior layout.

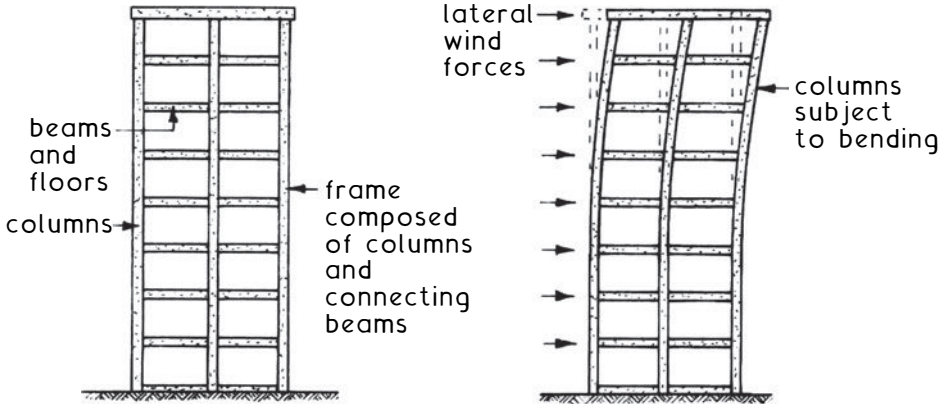

Core Structures ~ these are designed with a rigid structural core extending the full height of the building. The core is located centrally and the void within it is used to contain lifts and stairs. Lateral wind forces are transferred from the external wall cladding through the floor structure and into the core.

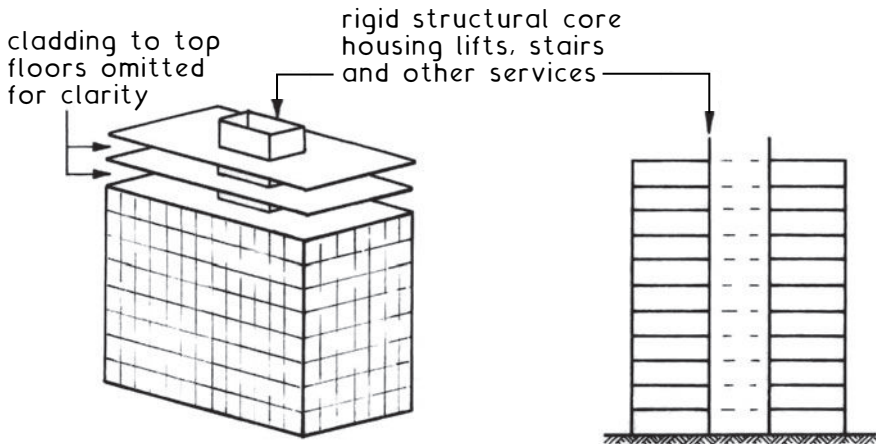



## Structures for Height - Systems (2)

Hull or Tube Core ~ a variation of the central core structure shown on the preceding page, whereby the perimeter wall and its structural bracing contain all the floor area. The outer framing, bracing and cladding is known as the hull and it functions structurally with the internal core through the intermediary floors. The result is a rigid form of construction with a design potential for very tall buildings.

rigid structural  
core housing  
lifts, stairs etc.

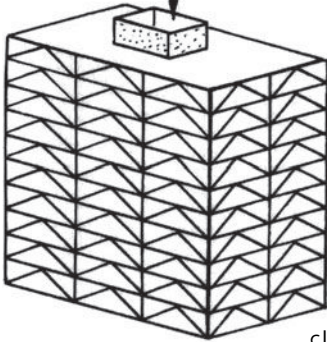

alternative  
braced  
rigid  
framing



cladding to  
top floors  
omitted  
for clarity

rigid end shear wall  
rigid internal shear wall

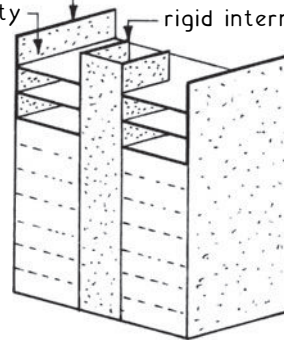

Shear Wall ~ lateral loading is resisted by rigid reinforced concrete external and internal walls. Floors act as diaphragms that transmit the lateral wind loads from façade cladding to shear walls. Long rectangular plan shaped buildings are suited to this design.

Diagonal Braced ~ a steel variation of the concrete shear wall. Structural walls are substituted with steel bracing which is in effect a series of vertical steel trusses. Columns are designed solely as compression members.

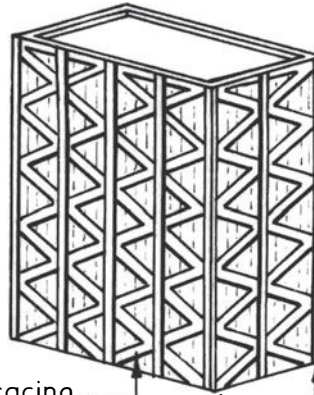

bracing columns

Suspended, Propped and Cantilevered ~ variations on a design theme that reduce the ground space occupied by the structural components. This facilitates unimpeded and sheltered pedestrian and vehicular access.

Suspended ~ uses a central services structural core to resist lateral forces and to transmit vertical loads to the foundations. Floors are supported on beams secured to peripheral columns that hang from a roof level truss.

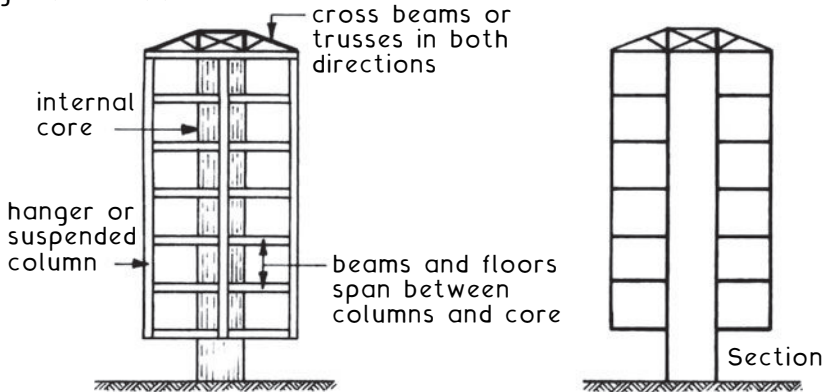

Propped ~ a first floor cantilevered reinforced concrete slab or a steel structure that forms a base for peripheral columns. These columns carry the floor beams and structural floor slabs.

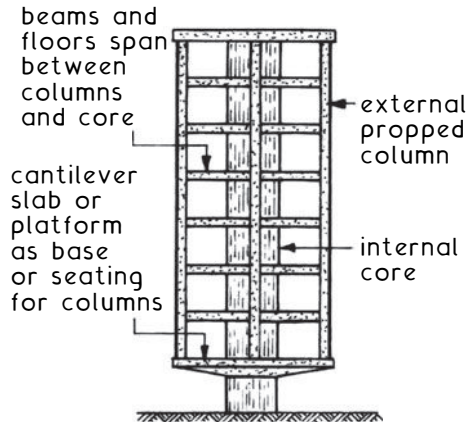

Cantilevered ~ each floor slab is cantilevered from a structural inner core.

Peripheral columns are not required and external cladding can be light weight infill panelling. The infilling must have sufficient structural resistance to lateral wind loads.

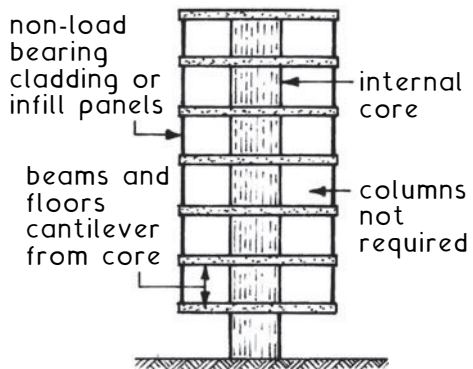

## Structures for Height - Systems (4)

Push-up ~ a steel frame construction method where the roof structure is assembled on the ground, then elevated by hydraulic jacking one floor at a time until the design height is achieved. At each floor lift, temporary supports are inserted whilst the space in between receives columns securely bolted to the preformed floor structure. The main advantage is a considerable reduction in the amount of heavy lifting plant and equipment needed by comparison with other construction methods. Also, with a roof covering applied, work at ground and upper floor levels can continue in all but extreme weather conditions.

Construction method ~

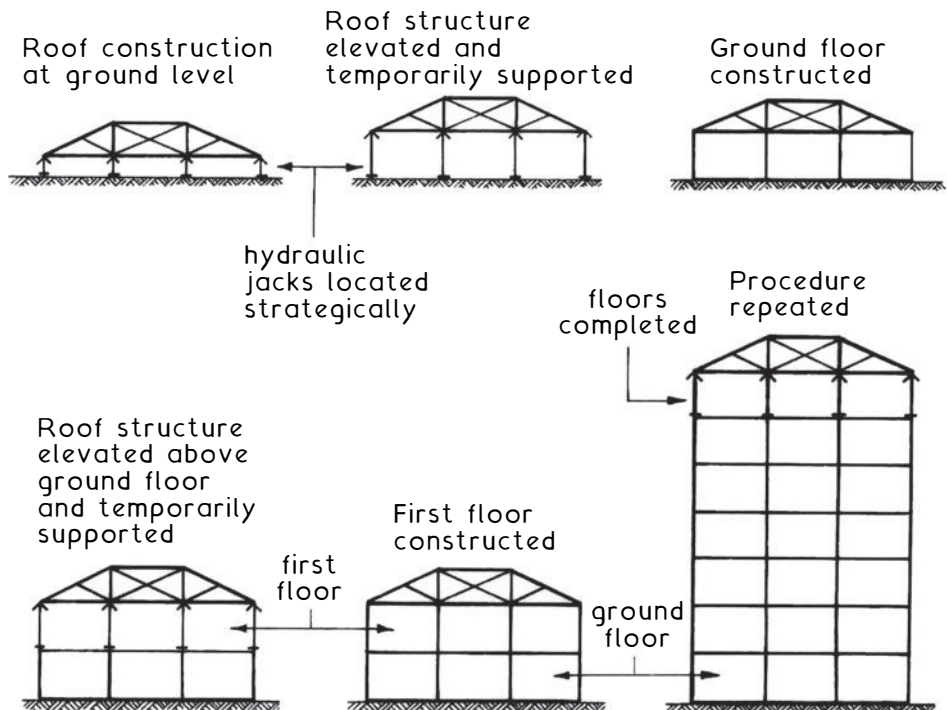

Steel Roof Trusses ~ these are triangulated plane frames which carry purlins to which the roof coverings can be fixed. Steel is stronger than timber and will not spread fire over its surface and for these reasons it is often preferred to timber for medium and long span roofs. The rafters are restrained from spreading by being connected securely at their feet by a tie member. Struts and ties are provided within the basic triangle to give adequate bracing. Angle sections are usually employed for steel truss members since they are economic and accept both tensile and compressive stresses. The members of a steel roof truss are connected together with bolts or by welding to shaped plates called gussets. Steel trusses are usually placed at 3.000 to 4.500 centres which gives an economic purlin size.

Typical Steel Roof Truss Formats ~

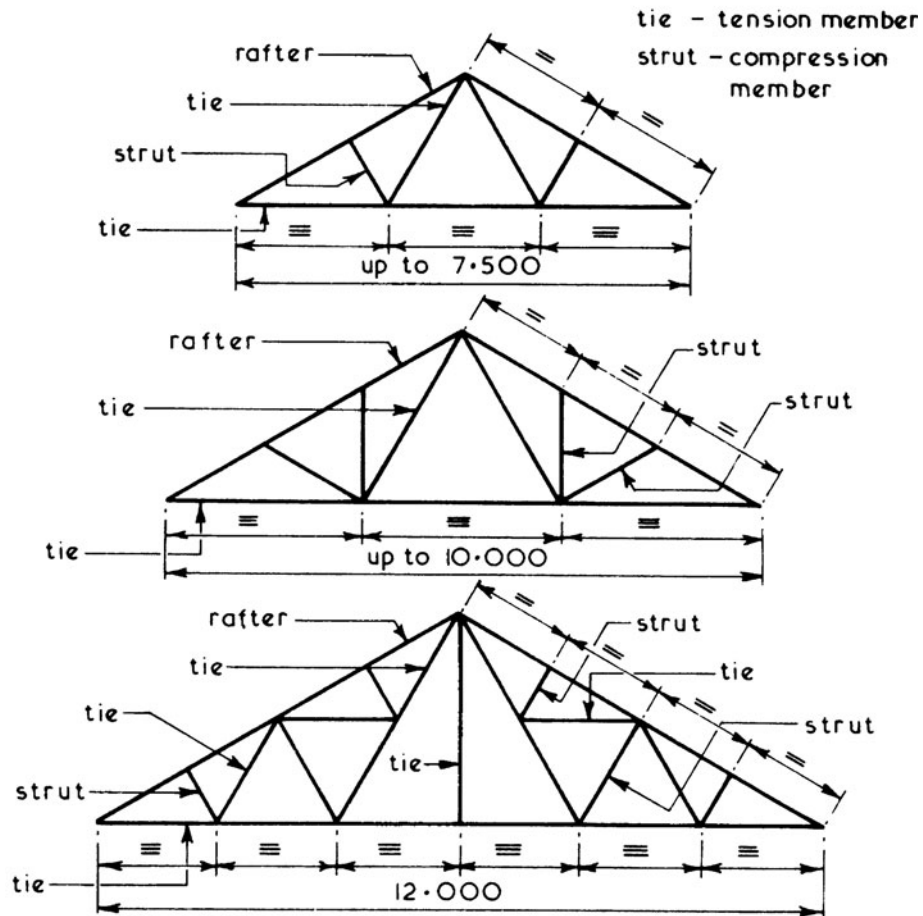

# Steel Roof Trusses up to 12 m Span

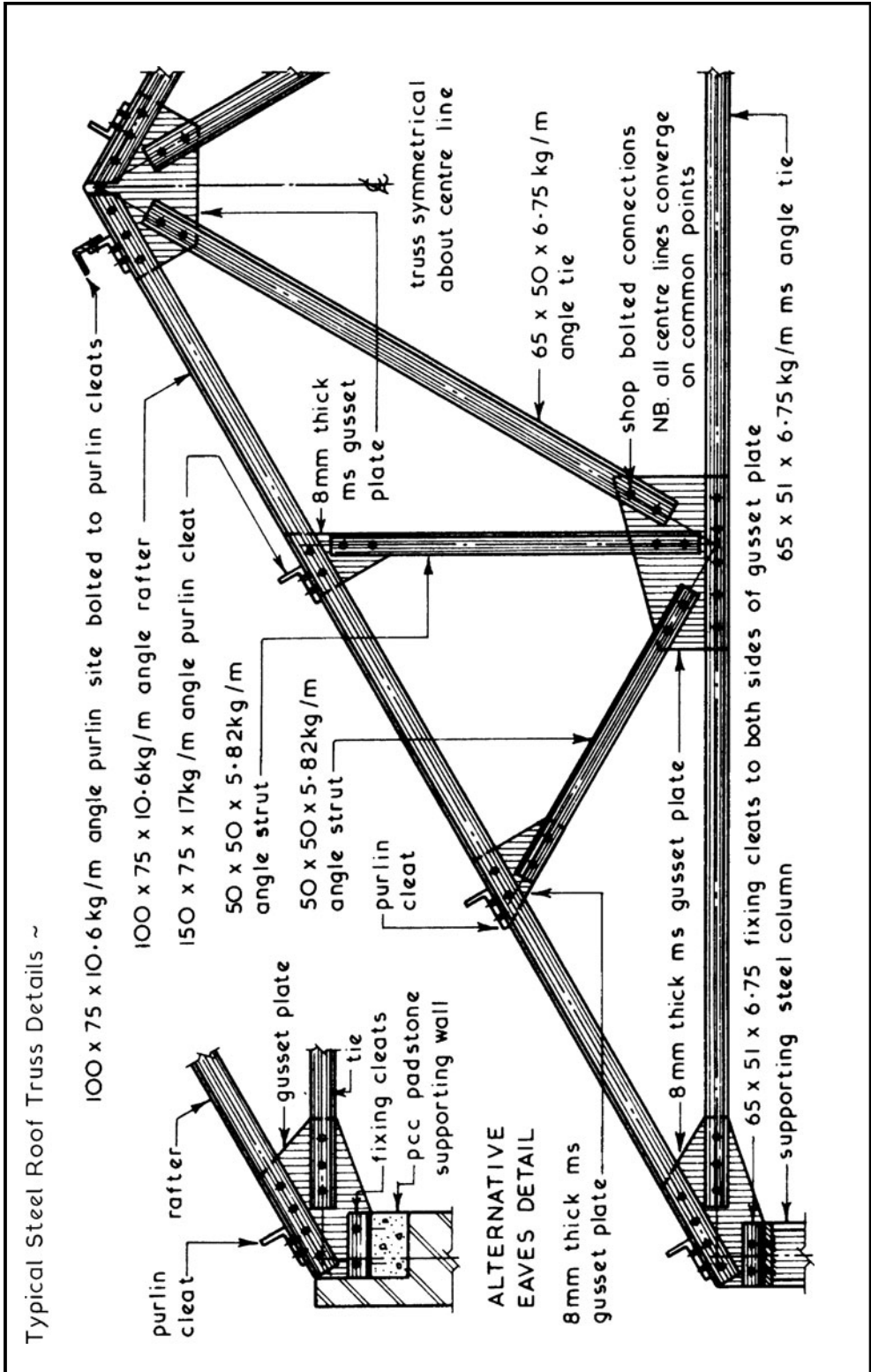

Sheet Coverings ~ the basic functions of sheet coverings used in conjunction with steel roof trusses are to:

1. Provide resistance to penetration by the elements.
2. Provide restraint to wind and snow loads.
3. Provide a degree of thermal insulation of not less than that set out in Part L of the Building Regulations.
4. Provide resistance to surface spread of flame as set out in Part B of the Building Regulations.
5. Provide any natural daylight required through the roof in accordance with the maximum permitted areas set out in Part L of the Building Regulations.
6. Be of low self-weight to give overall design economy.
7. Be durable to keep maintenance needs to a minimum.

Suitable Materials ~

Hot-dip galvanised corrugated steel sheets - BS 3083.

Aluminium profiled sheets - BS 4868.

Asbestos-free profiled sheets - various manufacturers whose products are usually based on a mixture of Portland cement, mineral fibres and density modifiers - BS EN 494.

Typical Profiles ~

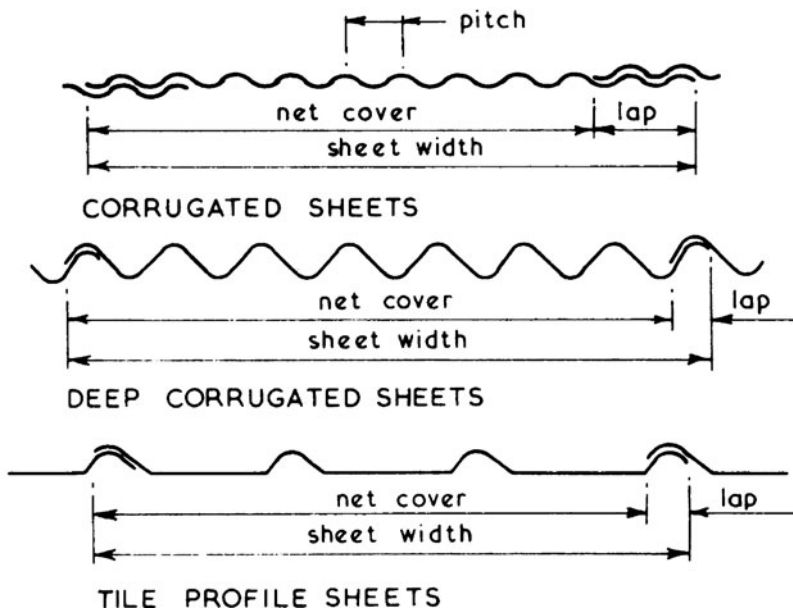

# Roof Sheet Coverings

## Typical Purlin Fixing Details ~

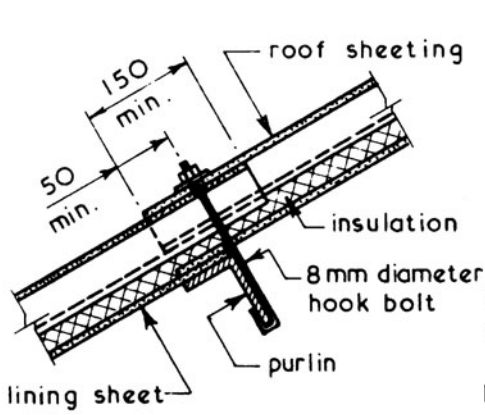

**STEEL ANGLE PURLIN**

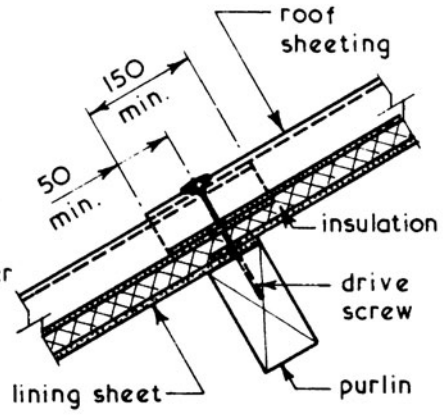

**TIMBER PURLIN**

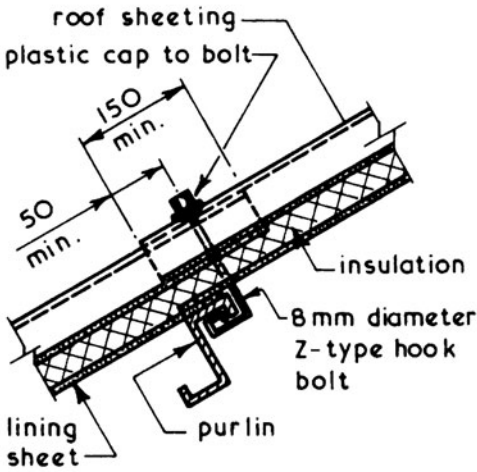

**ZED BEAM PURLIN**

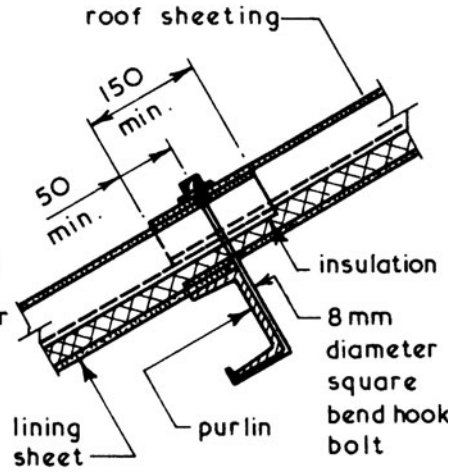

**STEEL CHANNEL PURLIN**

## Typical Fittings ~

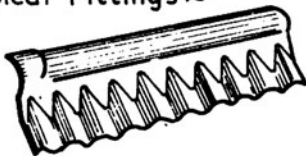

**CLOSE FITTING RIDGE PIECE**



**BARGE BOARD**

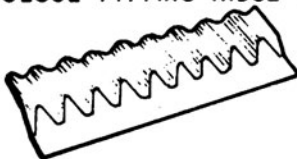

**EAVES FILLER PIECE**

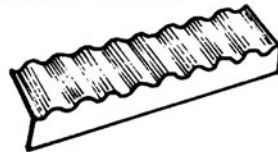

**EAVES CLOSURE PIECE**

Typical Details ~

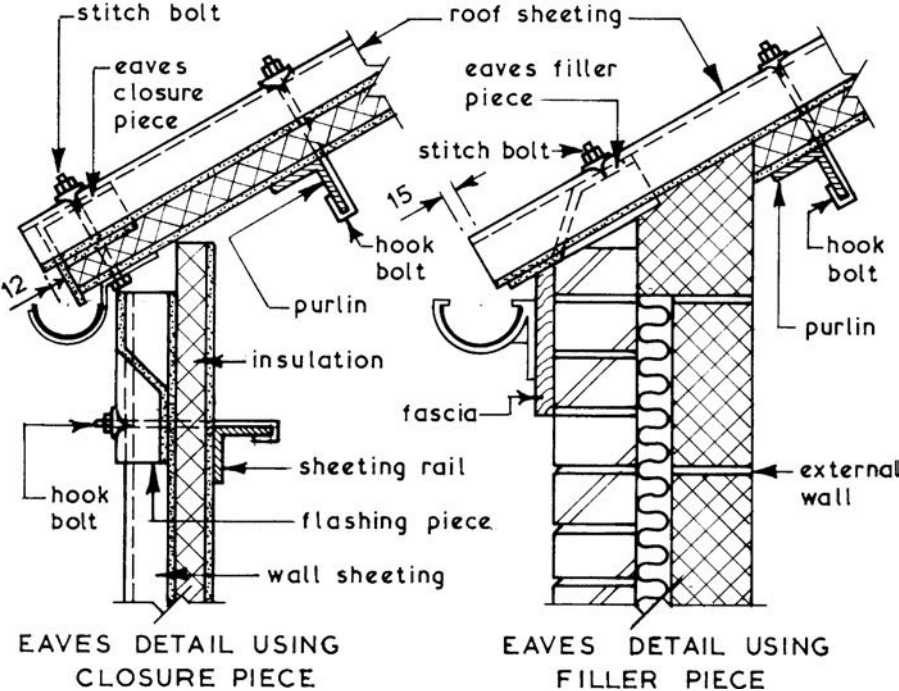
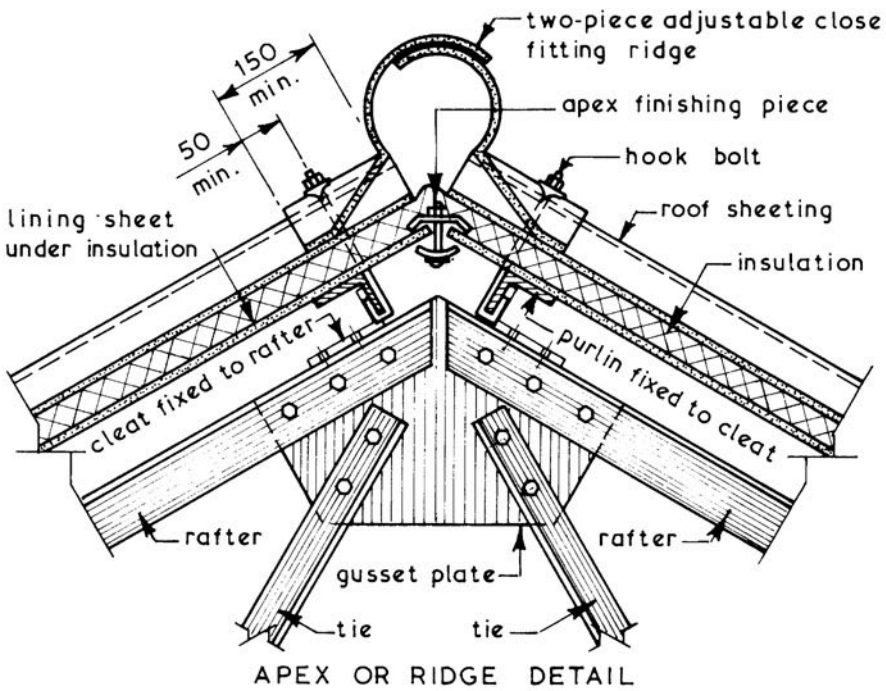



## Roof Sheet Coverings

Double Skin, Energy Roof Systems ~ apply to industrial and commercial use buildings. In addition to new projects constructed to current thermal insulation standards, these systems can be specified to upgrade existing sheet profiled roofs with superimposed supplementary insulation and protective decking. Thermal performance with resin bonded mineral wool fibre of up to 250 mm overall depth may provide U-values as low as 0.13 W/m<sup>2</sup>K.

### Typical Details ~

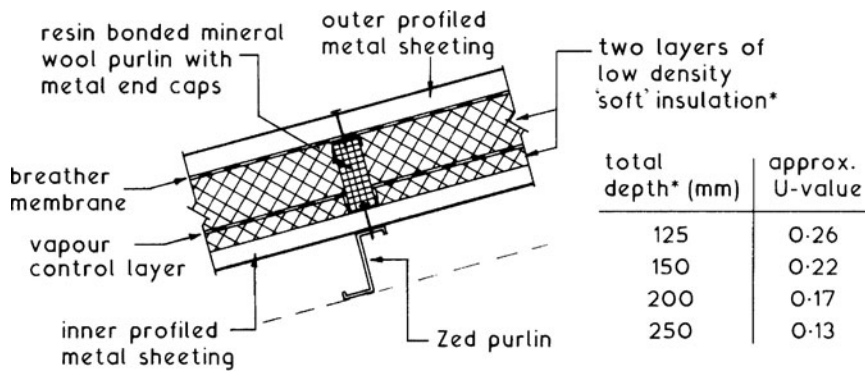

### Alternative ~

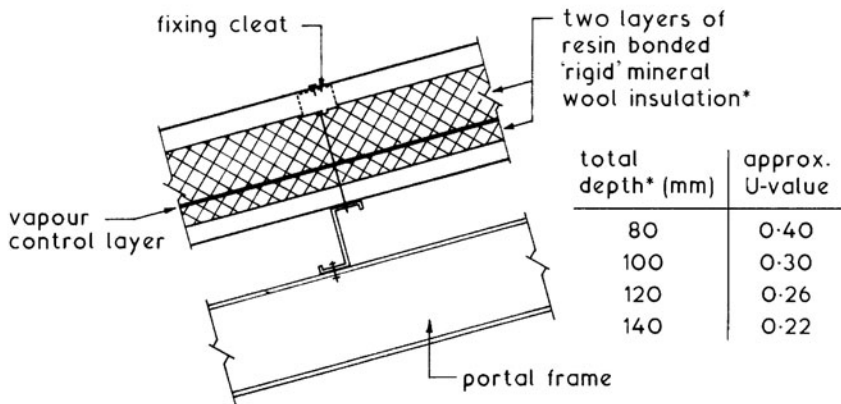

Further typical details using profiled galvanised steel or aluminium, colour coated if required ~

RIDGE

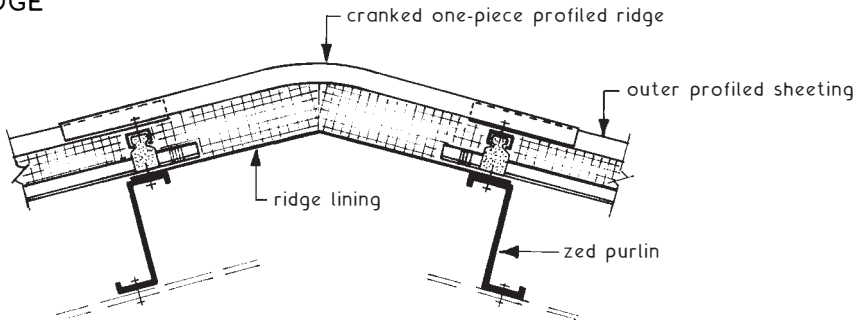

VALLEY GUTTER

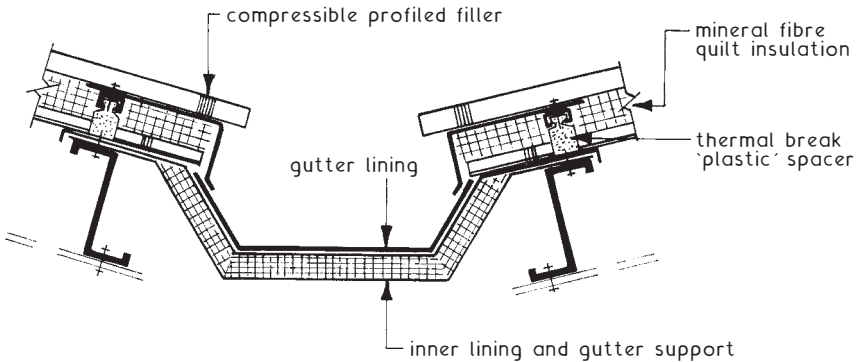

EAVES GUTTER

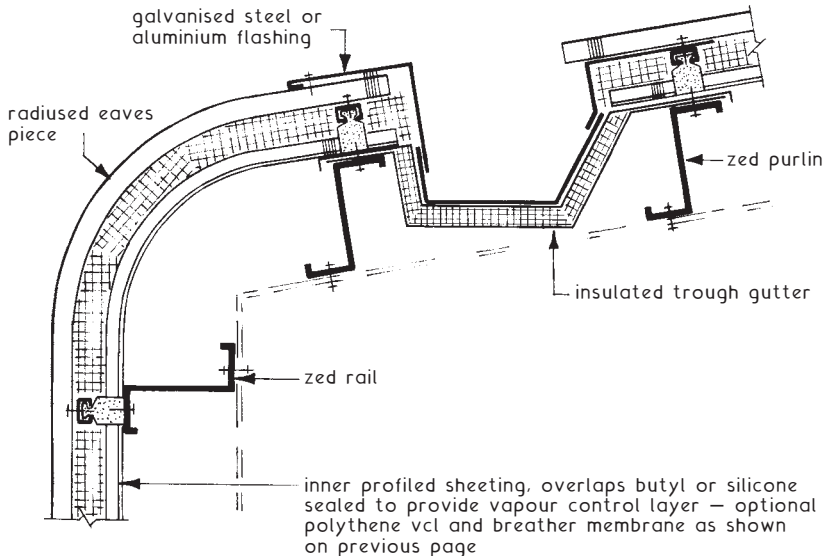

# Long Span Roofs

Long Span Roofs ~ these can be defined as those exceeding 12,000 in span. They can be fabricated in steel, aluminium alloy, timber, reinforced concrete and prestressed concrete. Long span roofs can be used for buildings such as factories, and large public halls and gymnasiums which require a large floor area free of roof support columns. The primary roof functions of providing weather protection, thermal insulation, sound insulation and restricting spread of fire over the roof surface are common to all roof types but these roofs may also have to provide strength sufficient to carry services lifting equipment and provide for natural daylight to the interior by means of rooflights.

## Basic Roof Forms ~

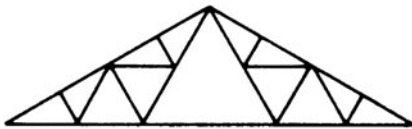

**Pitched Trusses** - spaced at suitable centres to carry purlins to which the roof coverings are fixed. Good rainwater run off - reasonable daylight spread from rooflights - high roof volume due to the triangulated format - on long spans roof volume can be reduced by using a series of short span trusses.

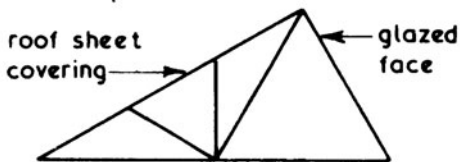

**Northlight** - spaced at suitable centres to carry purlins to which roof sheeting is fixed. Good rainwater run off - if correctly orientated solar glare is eliminated - long spans can be covered by a series of short span frames.

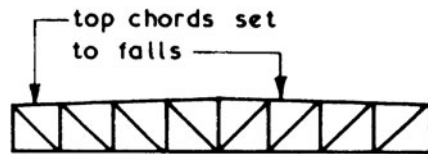

**Flat Top Girders** - spaced at suitable centres to carry purlins to which the roof coverings are fixed. Low pitch to give acceptable rainwater run off - reasonable daylight spread from rooflights - can be designed for very long spans but depth and hence roof volume increases with span.

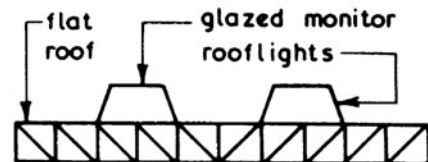

**Monitor** - girders or cranked beams at centres to suit low pitch decking used. Good even daylight spread from monitor lights which is not affected by orientation of building.

Pitched Trusses ~ these can be constructed with a symmetrical outline (as shown on pages 663 and 664) or with an asymmetrical outline (Northlight - see detail below). They are usually made from standard steel sections with shop welded or bolted connections. Alternatively they can be fabricated using timber members joined together with bolts and timber connectors or formed as a precast concrete portal frame.

Typical Multi-span Northlight Roof Details ~

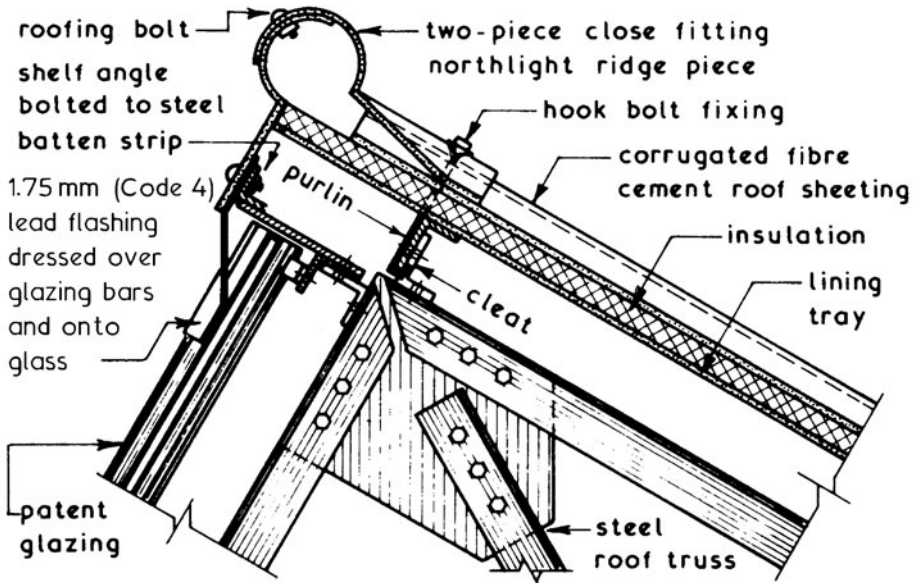

NORTHLIGHT RIDGE DETAIL

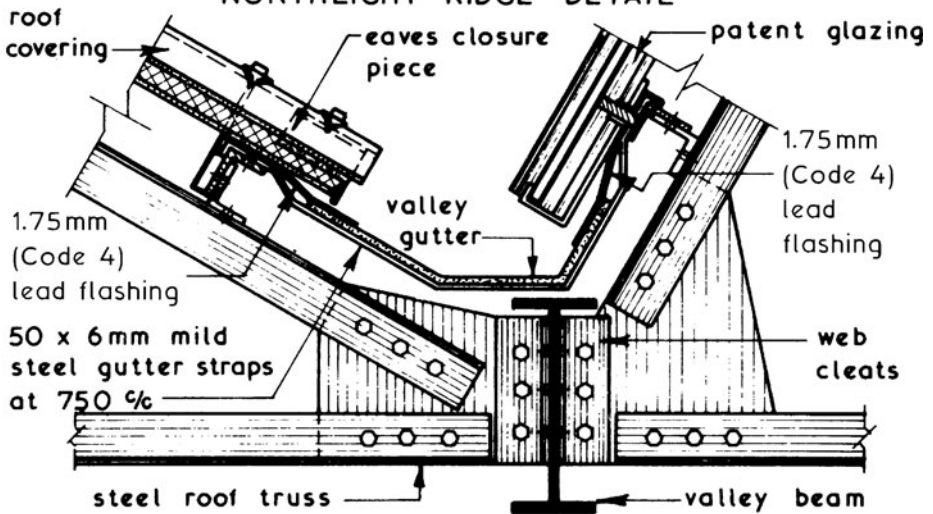

NORTHLIGHT VALLEY DETAIL

Monitor Roofs ~ these are basically a flat roof with raised glazed portions called monitors which forms a roof having a uniform distribution of daylight with no solar glare problems irrespective of orientation and a roof with easy access for maintenance. These roofs can be constructed with light long span girders supporting the monitor frames, cranked welded beams following the profile of the roof or they can be of a precast concrete portal frame format.

Typical Monitor Roof Details ~

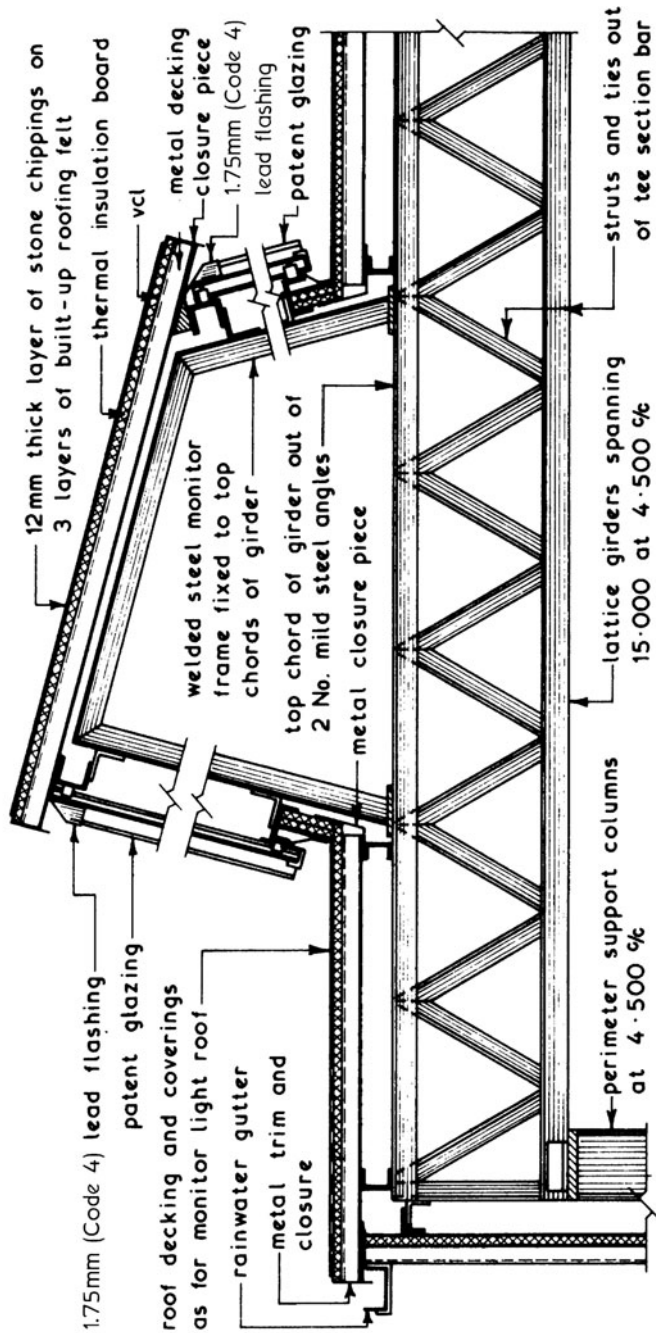

Flat Top Girders ~ attributed to Thomas Pratt an American engineer who with his father Caleb, patented their original truss design in 1844. Suitable for roof spans up to about 45 m. Effectively low pitched lattice beams used to carry purlins which support the roof coverings. One of the main advantages of this form of roof is the reduction in roof volume. The usual materials employed in the fabrication of flat top girders are timber and steel.

Typical Flat Top (Pratt Type) Girder Details ~

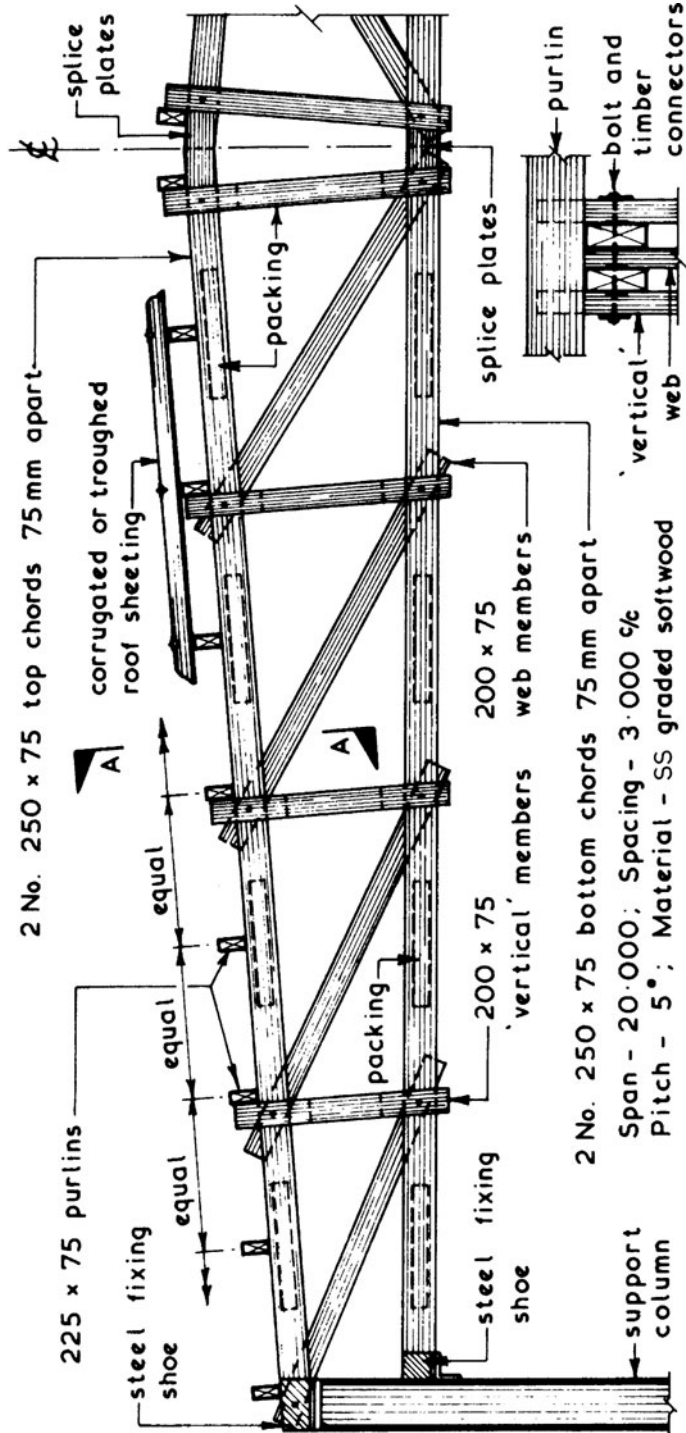

Vierendeel Girder ~ developed during the 1890s by Belgian civil engineer, Arthur Vierendeel (1852-1940). A type of rigid jointed structural frame without diagonal members. Traditionally made up from steel plates, whilst contemporary versions use standard steel profiles such as square sections welded at abutments. The large rectangular openings can feature glazing; an appropriate infilling for long span elevated footways.

Typical Vierendeel Girder of Traditional Steel Plate Manufacture ~

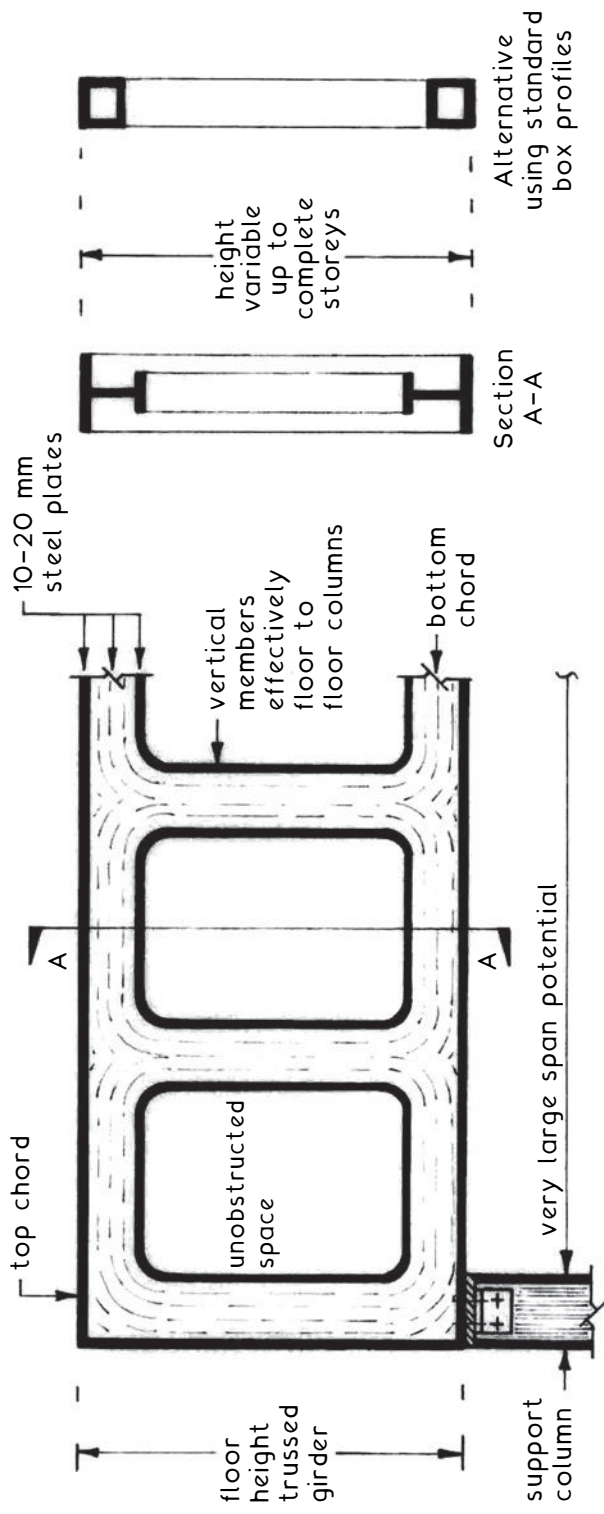

Unlike pin-jointed trusses with diagonal members, structural integrity relies on fixed or rigid joints to accommodate shear forces.

**Bowstring Truss** ~ a type of lattice truss formed with a curved upper edge. Bows and strings may be formed in pairs of laminated timber sections that are separated by solid web timber sections of struts and ties.

**Spacing** ~ 4.000 to 6.000 m apart depending on sizes of timber sections used and span.

**Purlins** ~ to coincide with web section meeting points and at about 1.000 m interim intervals.

**Decking** ~ sheet material suitably weathered or profiled metal sheeting. Thermally insulated relative to application.

**Top bow radius** ~ generally taken as between three-quarters of the span and the whole span.

**Application** ~ manufacturing assembly areas, factories, aircraft hangers, exhibition centres, sports arenas and other situations requiring a very large open span with featured timbers. Standard steel sections may also be used in this profile where appearance is less important, e.g. railway termini.

**Variation** ~ the Belfast truss that pre-dates the standard bowstring shown. It has much smaller interlaced struts and ties and is therefore more complicated in terms of assembly and for calculation of stress distribution. See next page.

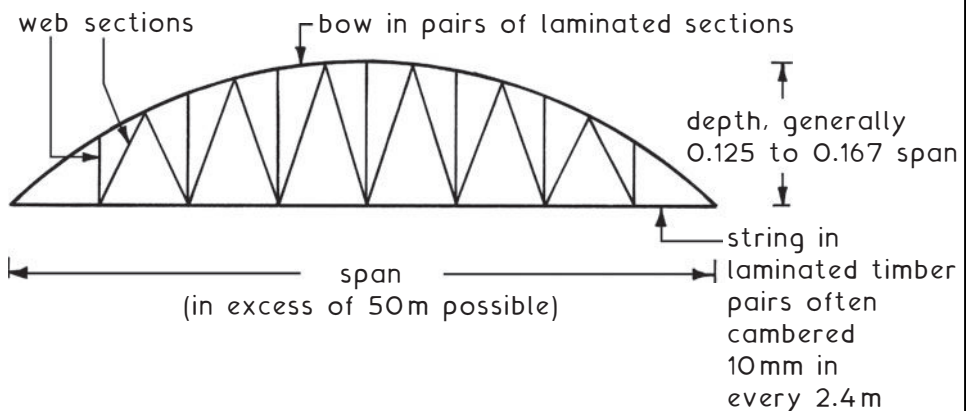



## Long Span Roofs

Belfast Truss ~ established as one of the earliest forms of bowstring truss for achieving an efficient and economical roof construction over large spans. It was first used in the latter part of the 19th century and early part of the 20th century for industrial and agricultural buildings in response to the need for space uninterrupted by walls and columns within production, assembly and storage areas. A contribution to the name was a truss design devised by Messrs D. Anderson and Son, Ltd of Belfast, for supporting their patent roofing felt.

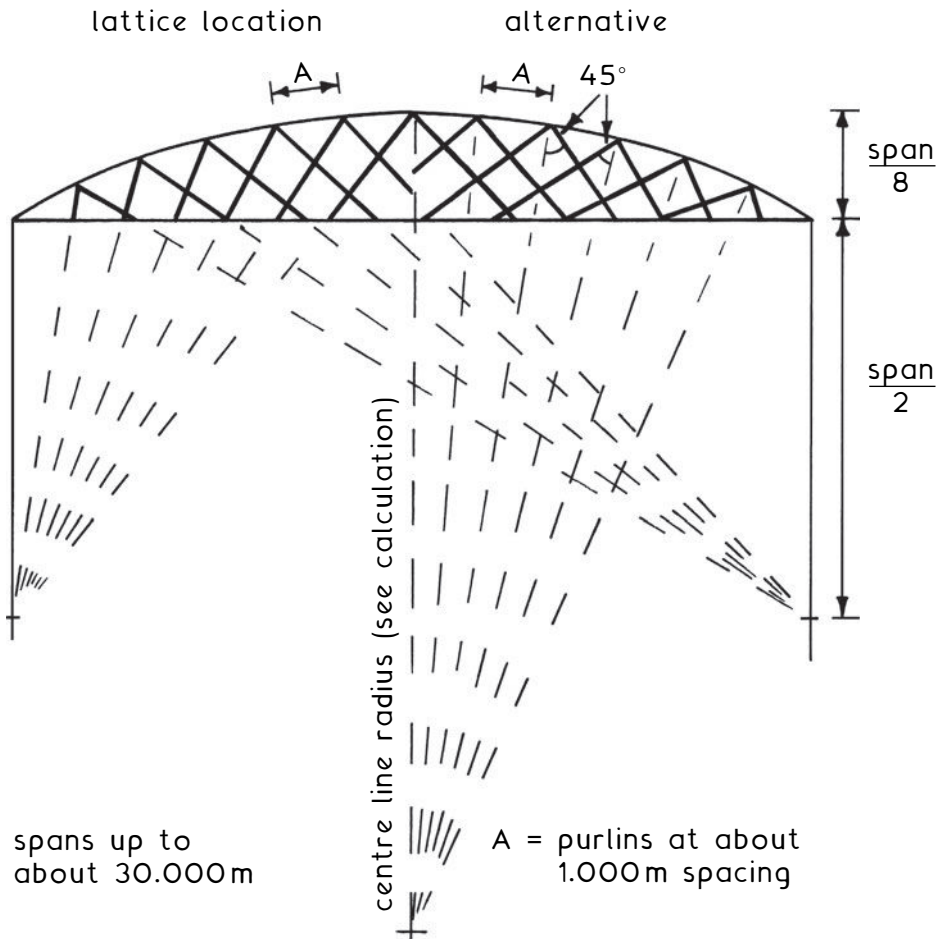

Centre line radius =  $[(0.5 \times \text{span})^2 + (\text{rise})^2] \div (2 \times \text{rise})$

E.g. A 16 m span with a rise of  $0.125 \times \text{span}$ .

Therefore, rise of truss =  $0.125 \times 16 = 2 \text{ m}$ .

Centre line radius =  $[(0.5 \times 16)^2 + (2)^2] \div (2 \times 2)$   
 $= 68 \div 4 = 17 \text{ m}$ .

Bowed Lattice Truss Details ~

Bowstring ~

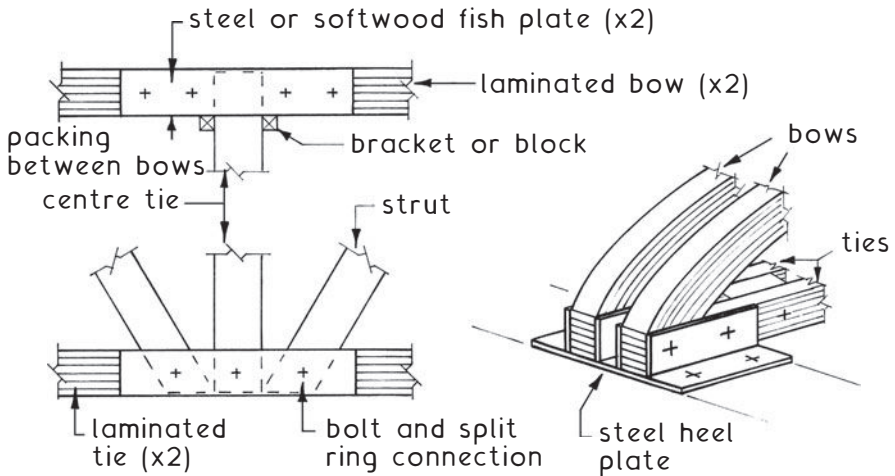

Belfast ~

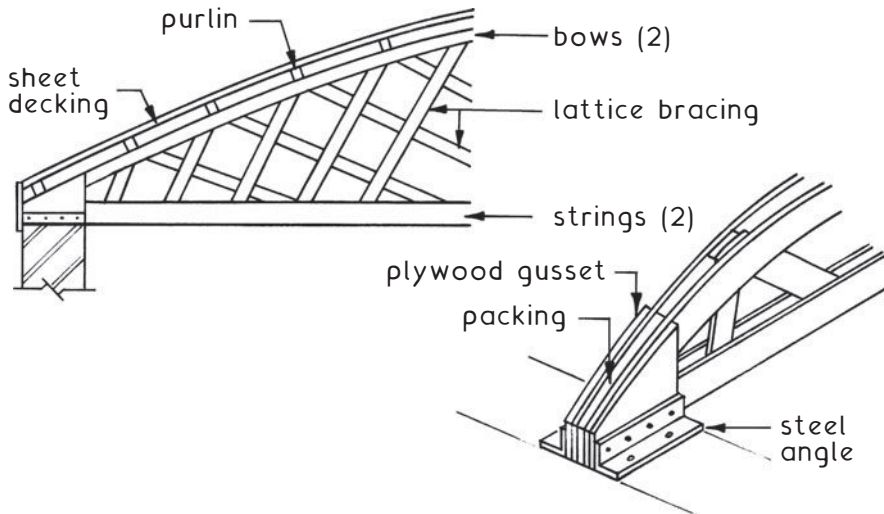

Typical softwood timber dimensions ~

Span (m)	6	12	18	24
Bow × 2 (mm)	38 × 20	63 × 25	75 × 32	75 × 50
String × 2 (mm)	125 × 20	200 × 25	250 × 32	300 × 50
Lattices (mm)	75 × 20	75 × 25	100 × 25	125 × 25

## Long Span Roofs

Connections ~ nails, screws and bolts have their limitations when used to join structural timber members. The low efficiency of joints made with a rigid bar such as a bolt is caused by the usual low shear strength of timber parallel to the grain and the non-uniform distribution of bearing stress along the shank of the bolt -

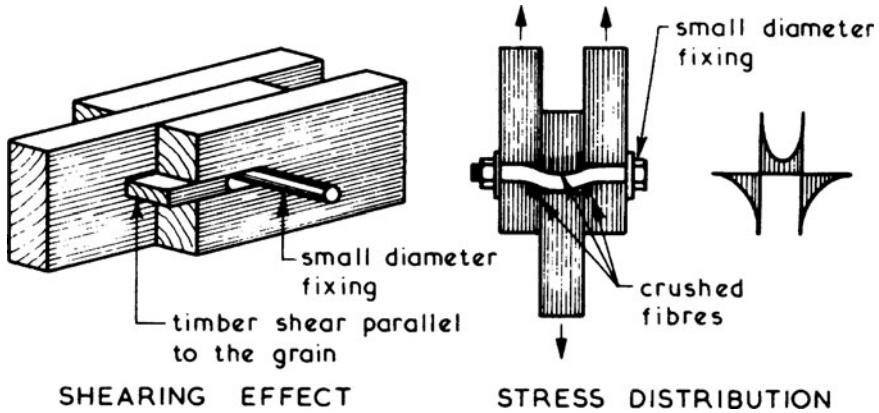

Timber Connectors ~ these are designed to overcome the problems of structural timber connections outlined above by increasing the effective bearing area of the bolts.

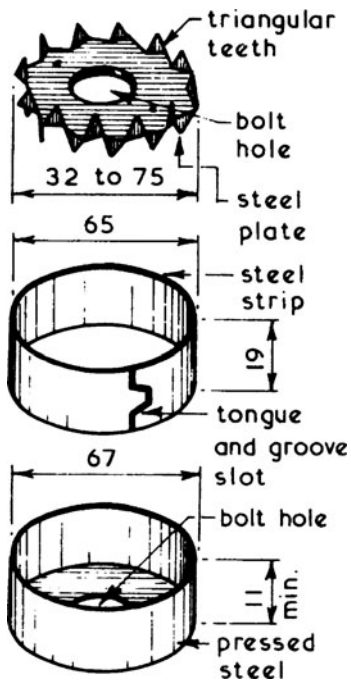

Toothed Plate Connector - provides an efficient joint without special tools or equipment - suitable for all connections especially small sections - bolt holes are drilled 2 mm larger than the bolt diameter, the timbers forming the joint being held together whilst being drilled.

Split Ring Connector - very efficient and develops a high joint strength - suitable for all connections - split ring connectors are inserted into a precut groove formed with a special tool making the connector independent from the bolt.

Shear Plate Connector - counterpart of a split ring connector - housed flush into timber - used for temporary joints.

Space Deck ~ a roofing system based on a combination of repetitive inverted pyramidal units to give large clear spans of up to 22m for single span designs and up to 33m for two-way spans. Each unit consists of a square frame of steel angles connected with steel tubular bracing to a cast steel apex boss. The connecting boss has four threaded holes to receive horizontal high tensile steel tie bars. Threads are left and right handed at opposing ends of the tie bar to match corresponding threads in the boss. As the bar is rotated both ends tighten into a boss. Tie bars can be varied in length to alter the spacing of apex boss connectors. This will induce tension in the upper frame forming a camber for surface water drainage.

Assembly ~ usually transported to site as individual units for assembly into beams and complete space deck at ground level before crane hoisting into position onto the perimeter supports. A lightweight insulated structural roof deck system is appropriate in combination with rooflights mounted directly onto individual units if required.

Standard Unit Dimensions ~

1.2 m × 1.2 m on plan with depths of 750 mm or 1.2 m.

1.5 m × 1.5 m on plan with depths of 1.2 m or 1.5 m.

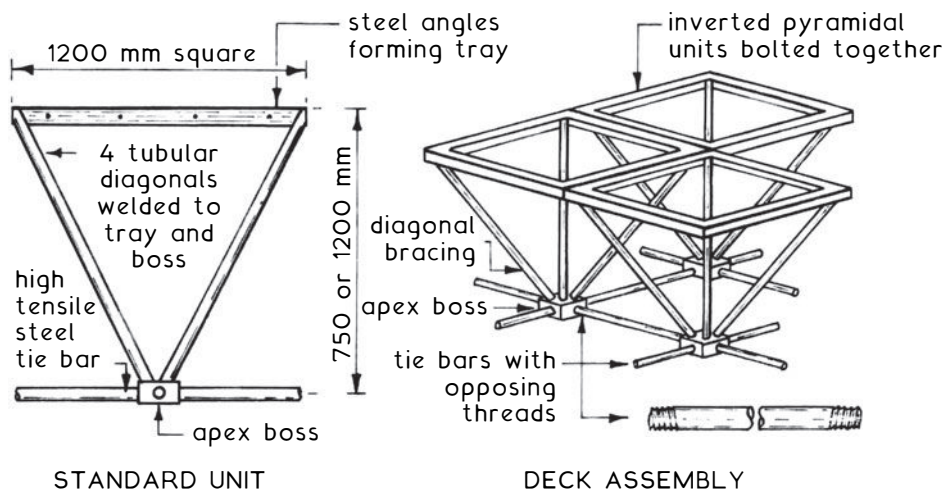

# Long Span Roofs - Space Grid Structures

Space Deck Frame Support ~ can be on columns or a peripheral ring beam through purpose made bearing joints. These joints should be designed with adequate strength to resist and transmit vertical and horizontal loads that combine compressive and tensile forces.

Edge Treatment and Finishes ~ various possibilities; these include vertical fascias, mansard and cantilever.

Space Deck Edge Fixings and Finishes ~

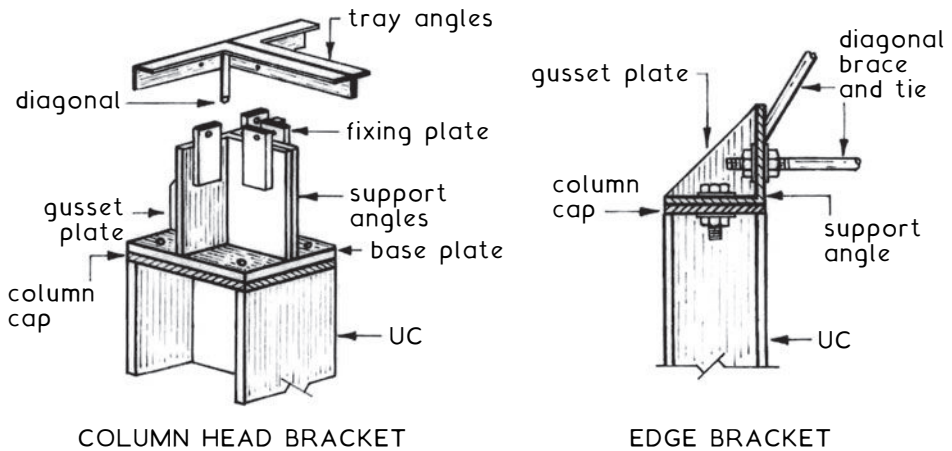
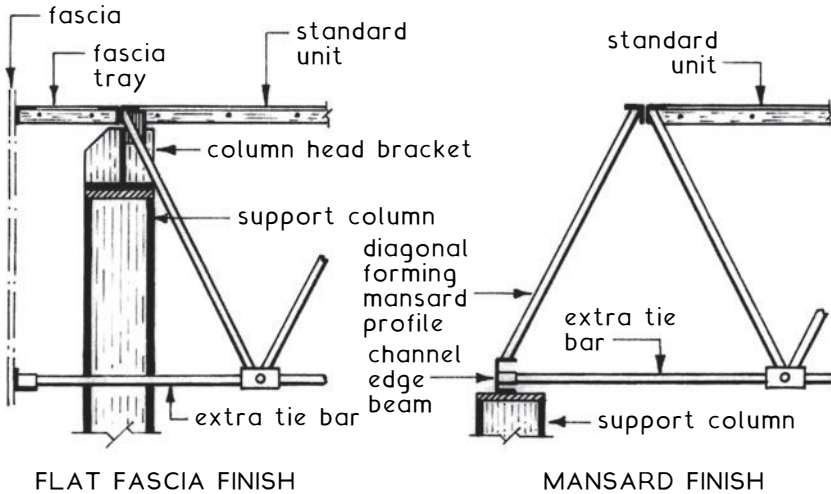

Space Frame ~ a concept based on a three-dimensional framework of structural members pinned at their ends, i.e. four joints or nodes that combine to produce a simple tetrahedron. As a roofing system it uses a series of connectors to join chords and bracing members. Single or double layer grids are possible, the former usually employed for assembling small domes or curved roofs. Space frames are similar in concept to space decks but they have greater flexibility in design and layout possibilities. Steel or aluminium alloy tubes have been the favoured material for space frames. Fibre reinforced composites are also viable.

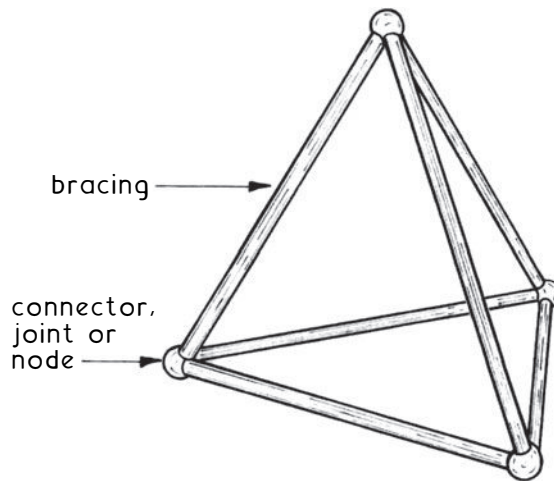

Origins ~ initially attributed to Alexander Bell (1847–1922), perhaps better known as the inventor of the telephone. During the early 1900s he experimented with octahedral and tetrahedral space truss structures. It was much later before the potential for space grid structures was recognised and produced commercially. One of the earliest being the German MERO system developed by Max Mengerhausen (1903-1988) in the 1940s. Its name was devised from an abbreviation of MEngerhausen ROhrbauweise. In the 1960s and 1970s space frame technology moved into a new generation of super-systems capable of very long spans often exceeding 50 m. It is from the basis of the technological principles established during this era that contemporary applications are now designed.

# Long Span Roofs - Space Grid Structures

Examples of Space Frames ~

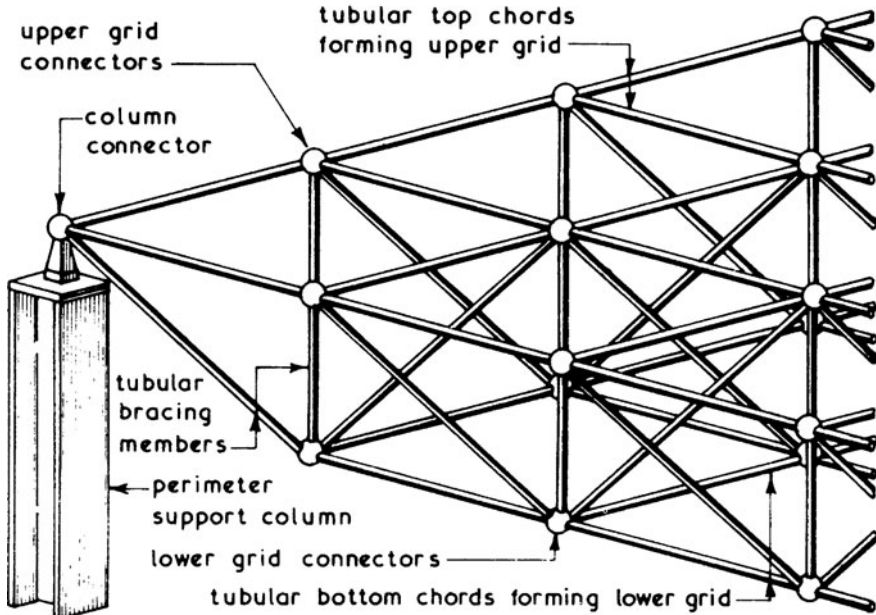
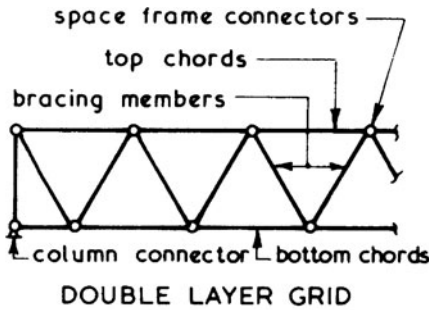
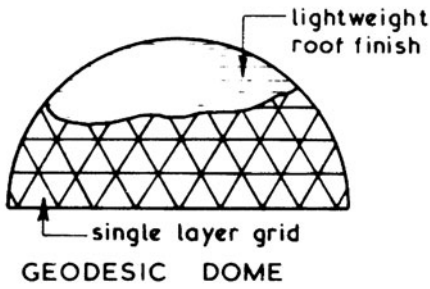

span to depth ratio 1:15 (corner supports) & 1:20 (edge supports)  
**TYPICAL DOUBLE LAYER GRID FORMAT**

Development ~ during the 1960s and 1970s investment in public and private company research led to numerous systems of long span space frames being developed and introduced on a commercial scale. One of the better known is the 'Nodus' system created by British Steel Corporation (later Corus, now TATA). This concept formed the basis for later improvements and many contemporary systems use the principles of nodal jointing compatible with standard manufactured tubular metal sections. See next page for details.

Notes:

- All factory fabrication, leaving simple assembly processes for site.
- Node steel castings in two parts with machined grooves and drilled holes. Machined steel teeth connector welded to chord ends.

# Long Span Roofs - Space Grid Structures

Space Frame Concept Based on the 'Nodus' System of Jointing ~

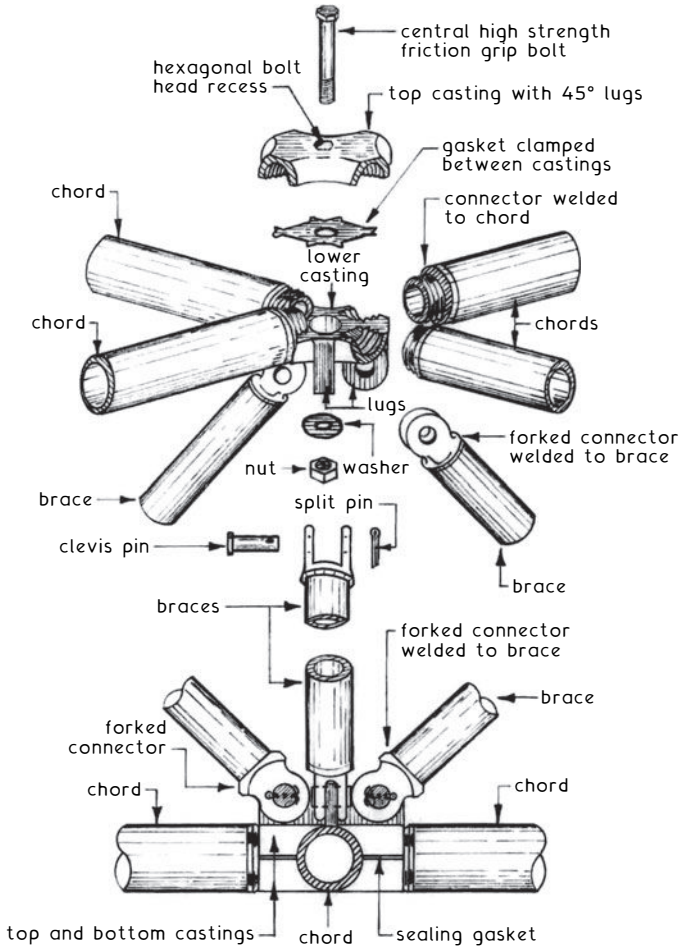
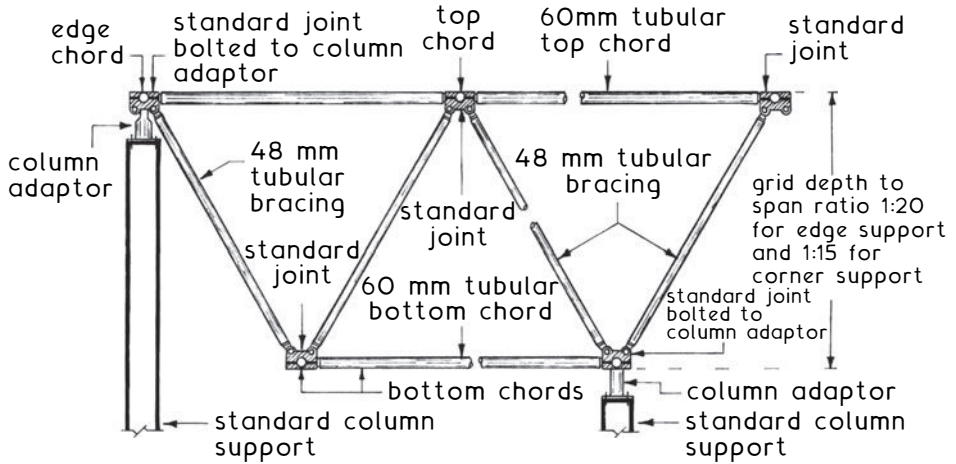



# Shell Roof Construction

Shell Roofs ~ these can be defined as a structural curved skin covering a given plan shape and area where the forces in the shell or membrane are compressive and in the restraining edge beams are tensile. The usual materials employed in shell roof construction are in-situ reinforced concrete and timber. Concrete shell roofs are constructed over formwork which in itself is very often a shell roof making this format expensive, since the principle of use and reuse of formwork cannot normally be applied. The main factors of shell roofs are:

1. The entire roof is primarily a structural element.
2. Basic strength of any particular shell is inherent in its geometrical shape and form.
3. Comparatively less material is required for shell roofs than for other forms of roof construction.

Domes ~ these are double curvature shells which can be rotationally formed by any curved geometrical plane figure rotating about a central vertical axis. Translation domes are formed by a curved line moving over another curved line whereas pendentive domes are formed by inscribing within the base circle a regular polygon and vertical planes through the true hemispherical dome.

Typical Examples ~

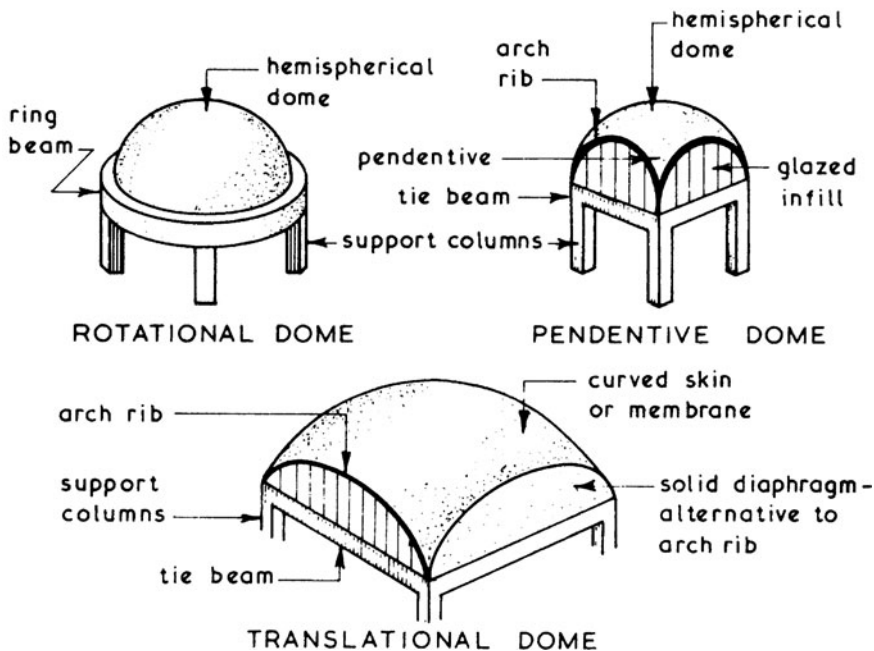

Barrel Vaults ~ these are single curvature shells which are essentially a cut cylinder which must be restrained at both ends to overcome the tendency to flatten. A barrel vault acts as a beam whose span is equal to the length of the roof. Long span barrel vaults are those whose span is longer than its width or chord length and conversely short barrel vaults are those whose span is shorter than its width or chord length. In every long span barrel vault thermal expansion joints will be required at 30-000 centres which will create a series of abutting barrel vault roofs weather sealed together (see next page).

Typical Single Barrel Vault Principles~

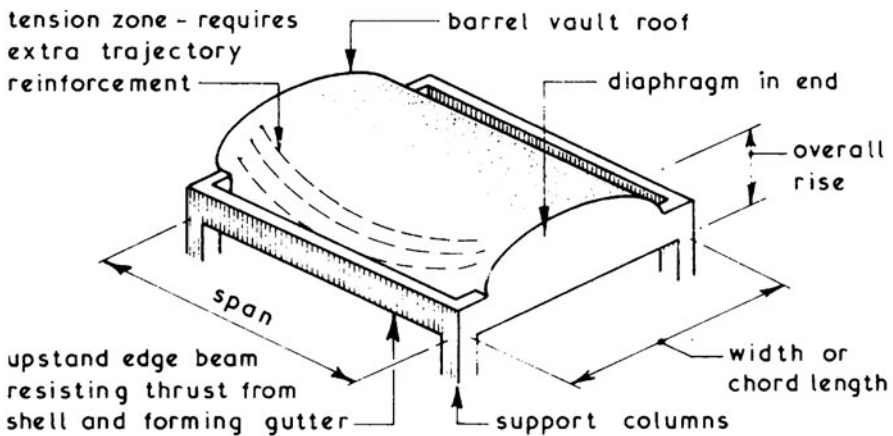

economic design ratios - width : span 1 : 2 to 1 : 5  
 rise : span 1 : 10 to 1 : 15

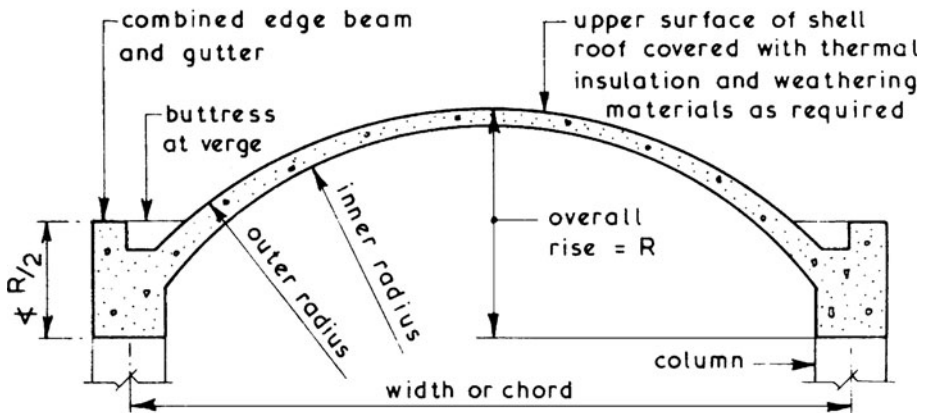

# Shell Roof Construction

## Typical Barrel Vault Expansion Joint Details ~

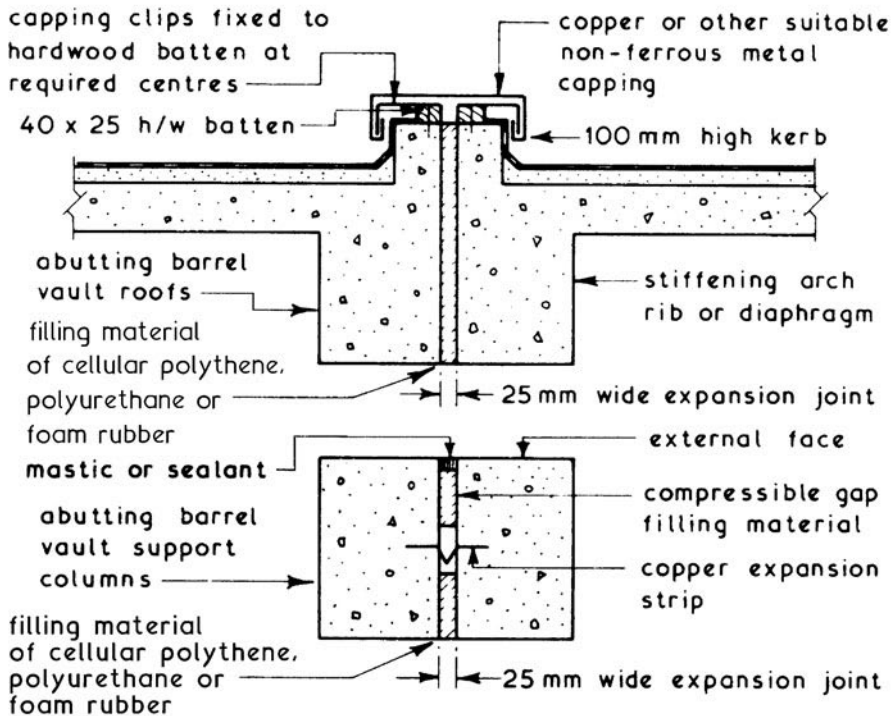

Stiffening Beams ~ short barrel vaults often have large chords of over 12·000. In such cases stiffening beams should be placed at 3·000 to 6·000 centres to prevent buckling.

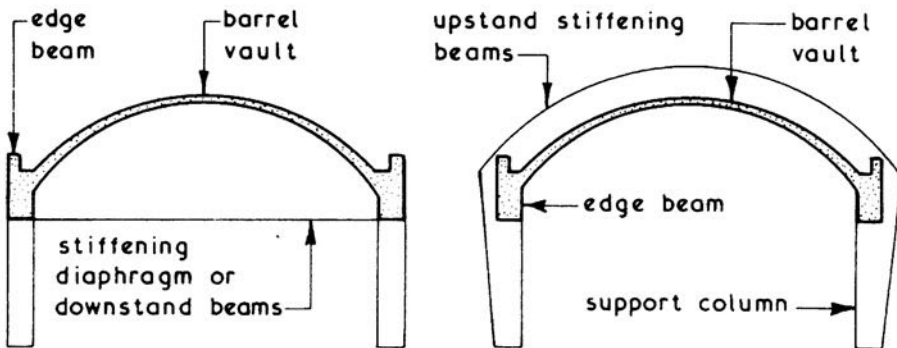

NB. Ribs not connected to support columns will set up extra stresses within the shell roof; therefore extra reinforcement will be required at the stiffening rib or beam positions.

Other Forms of Barrel Vault ~ by cutting intersecting and placing at different levels the basic barrel vault roof can be formed into a groin or northlight barrel vault roof:

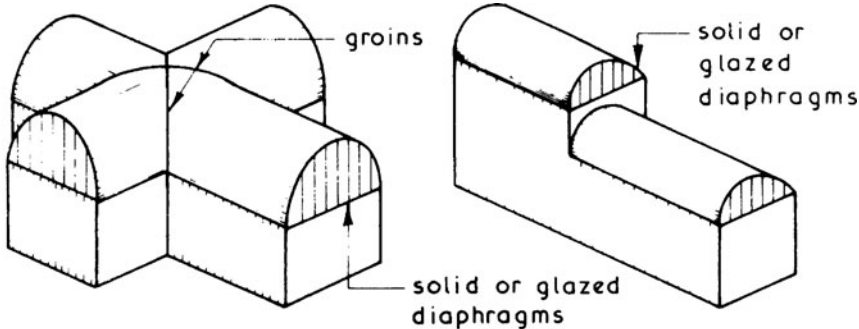

INTERSECTING BARREL VAULTS    STEPPED BARREL VAULTS

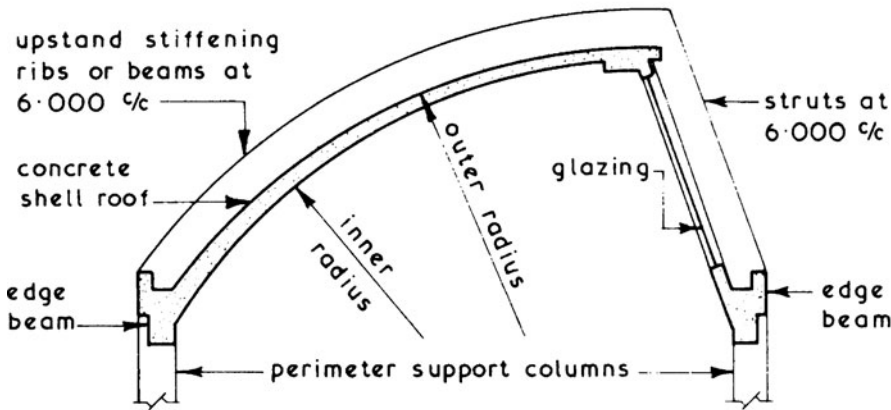

NORTHLIGHT BARREL VAULT

Conoids ~ these are double curvative shell roofs which can be considered as an alternative to barrel vaults. Spans up to 12.000 with chord lengths up to 24.000 are possible. Typical chord to span ratio 2:1.

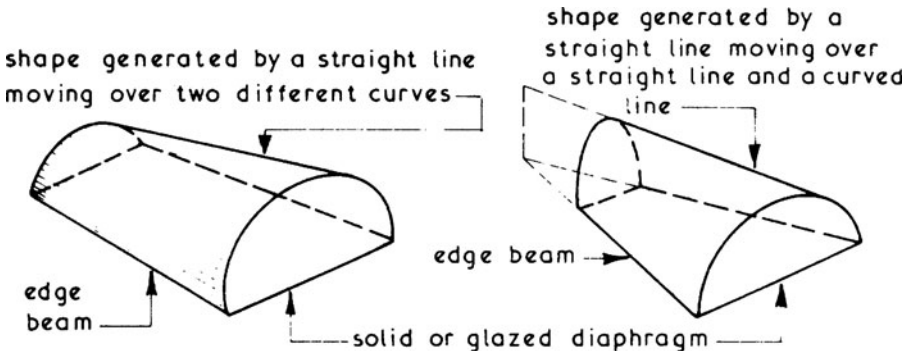

# Shell Roof Construction

Hyperbolic Paraboloids ~ the true hyperbolic paraboloid shell roof shape is generated by moving a vertical parabola (the generator) over another vertical parabola (the directrix) set at right angles to the moving parabola. This forms a saddle shape where horizontal sections taken through the roof are hyperbolic in format and vertical sections are parabolic. The resultant shape is not very suitable for roofing purposes; therefore only part of the saddle shape is used and this is formed by joining the centre points thus:

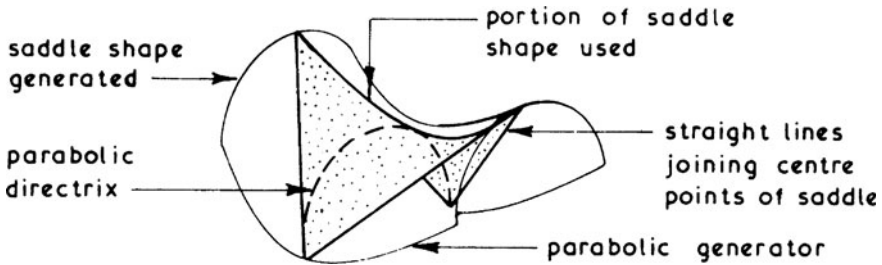

To obtain a more practical shape than the true saddle a straight line limited hyperbolic paraboloid is used. This is formed by raising or lowering one or more corners of a square forming a warped parallelogram thus:

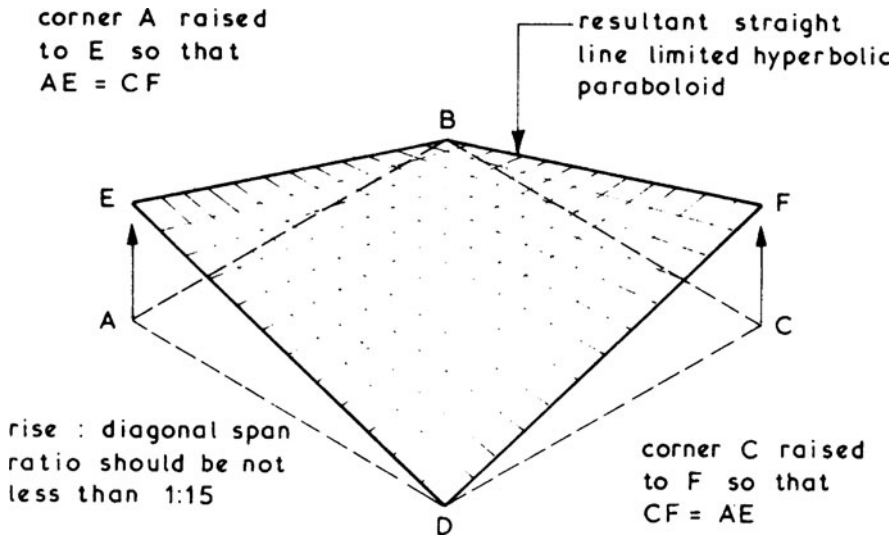

NB. For further examples see next page.

Typical Straight Line Limited Hyperbolic Paraboloid Formats ~

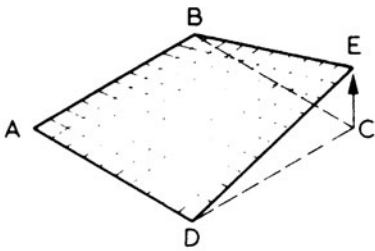

corner C raised to E

resultant hyperbolic paraboloid

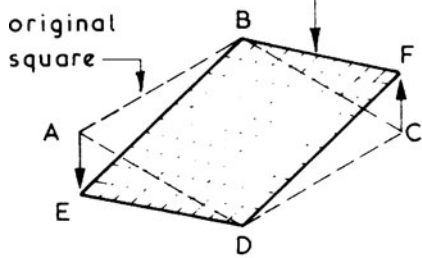

corner A lowered to E and corner C raised to F so that  $AE = CF$

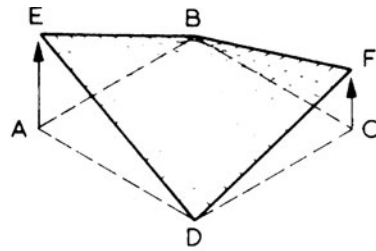

corner A raised to E and corner C raised to F so that  $AE \neq CF$

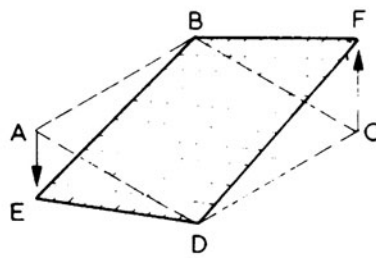

corner A lowered to E and corner C raised to F so that  $AE \neq CF$

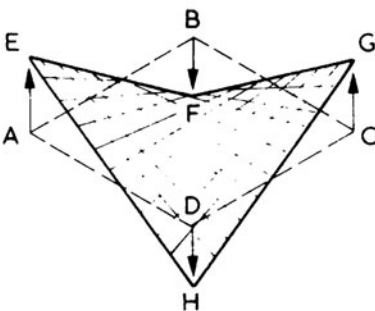

corners A & C raised to E & G  
corners B & D lowered to F & H  
so that  $AE = CG$  &  $BF = DH$

Combination of Hyperbolic Paraboloid Shell Roofs ~

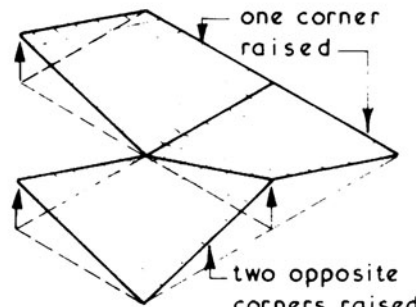

NB. Any combination possible.

## Shell Roof Construction

Concrete Hyperbolic Paraboloid Shell Roofs ~ these can be constructed in reinforced concrete (characteristic strength 25 or 30 N/mm<sup>2</sup>) with a minimum shell thickness of 50 mm with diagonal spans up to 35.000. These shells are cast over a timber form in the shape of the required hyperbolic paraboloid format. In practice therefore two roofs are constructed and it is one of the reasons for the popularity of timber versions of this form of shell roof.

Timber Hyperbolic Paraboloid Shell Roofs ~ these are usually constructed using laminated edge beams and layers of t & g boarding to form the shell membrane. For roofs with a plan size of up to 6.000 × 6.000 only two layers of boards are required and these are laid parallel to the diagonals with both layers running in opposite directions. Roofs with a plan size of over 6.000 × 6.000 require three layers of board as shown below. The weather protective cover can be of any suitable flexible material such as built-up roofing felt, copper and lead. During construction the relatively lightweight roof is tied down to a framework of scaffolding until the anchorages and wall infilling have been completed. This is to overcome any negative and positive wind pressures due to the open sides.

Typical Details ~

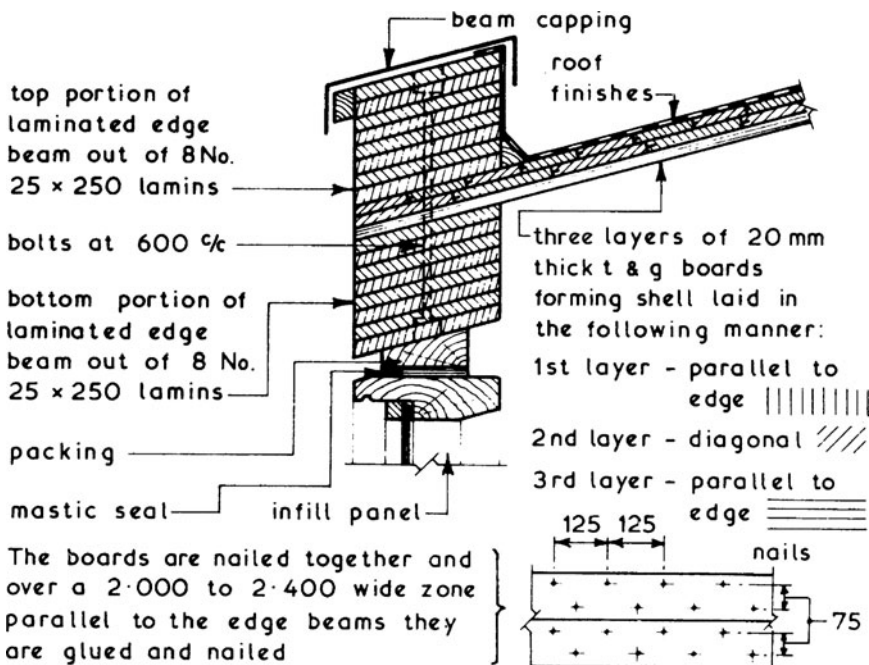

Support Considerations ~ in timber hyperbolic paraboloid shell roofs only two supports are required:

Edge beams are in compression forces  $P$  are transmitted to  $B$  and  $D$  resulting in a vertical force  $V$  and a horizontal force  $H$  at both positions; therefore support columns are required at  $B$  and  $D$ .

Vertical force  $V$  is transmitted directly down the columns to a suitable foundation. The outward or horizontal force  $H$  can be accommodated in one of two ways:

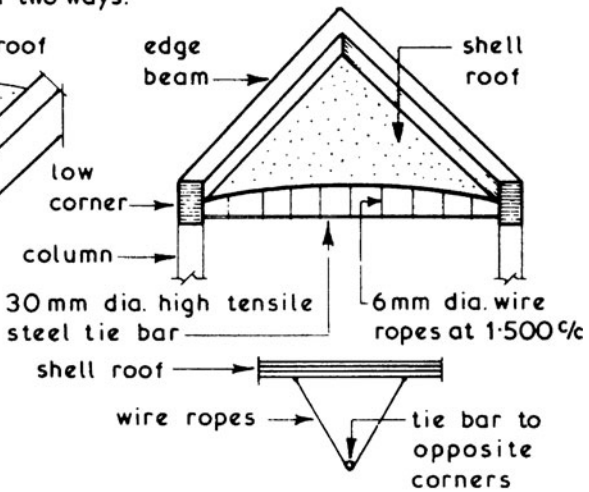
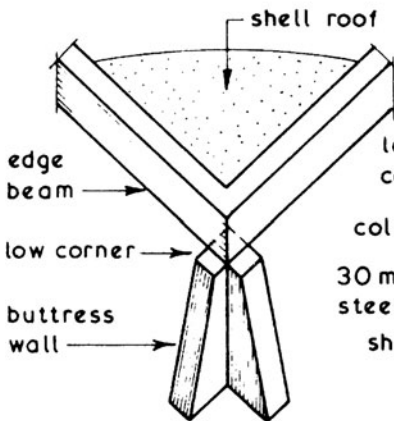
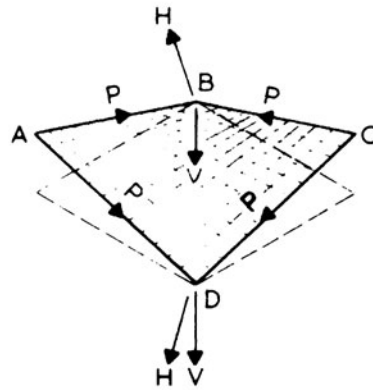

If shell roof is to be supported at high corners the edge beams will be in tension and horizontal force will be inwards. This can be resisted by a diagonal strut between the high corners.

Combination Roof Support Example ~

4 No. roof shells of equal loading joined together

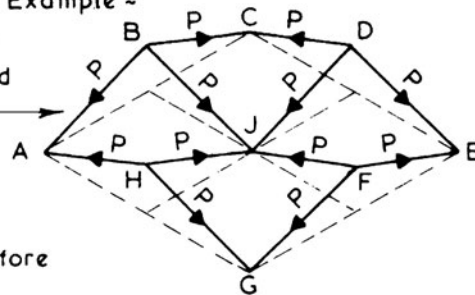

Supports required at A; C; G and E. with ties between AC; CE; EG and GA. Forces at J cancel each other out; therefore no support required at J.



## Folded Slab Roof Construction

A form of stressed skin reinforced concrete construction also known as folded plate construction. The concept is to profile a flat slab into folds so that the structure behaves as a series of beams spanning parallel with the profile.

Optimum depth to span ratio is between 1:10 to 1:15, or a depth to width of not less than 1:10, whichever is greater.

Roof format ~ pitched, monitor or multi-fold.

Pitched multi-fold  
depth

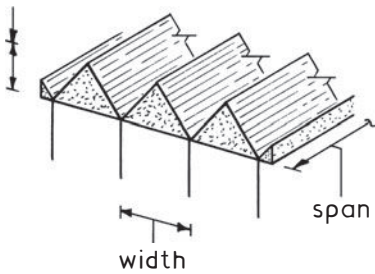

Monitor

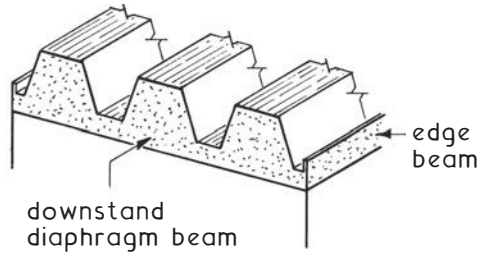

Several slabs of narrow thickness are usually preferred to a few wider slabs as this reduces the material dead loading. Numerous design variations are possible particularly where counter-folds are introduced and the geometry developed to include bowed or arched spans extending to the ground.

Typical main reinforcement

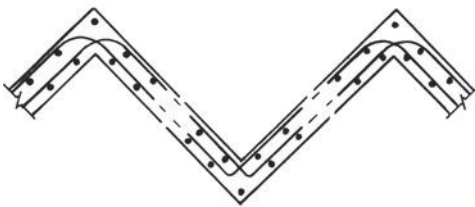

Counter-folded slab

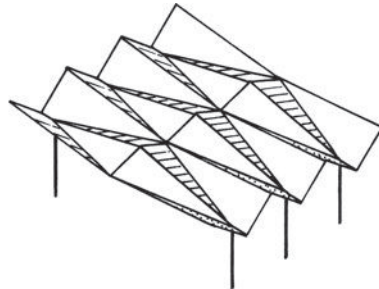

Membrane Structure Principles ~ a form of tensioned cable structural support system with a covering of stretched fabric. In principle and origin, this compares to a tent with poles as compression members secured to the ground. The fabric membrane is attached to peripheral stressing cables suspended in a catenary between vertical support members.

Form ~ there are limitless three-dimensional possibilities. The following geometric shapes provide a basis for imagination and elegance in design:

- Hyperbolic paraboloid (Hypar)
- Barrel vault
- Conical or double conical

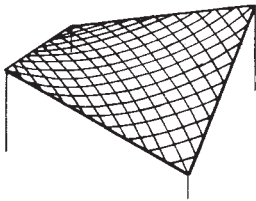

Hyperbolic paraboloid

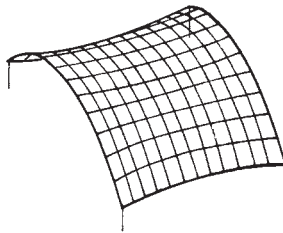

Barrel vault

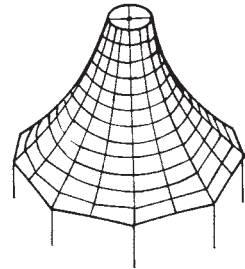

Conical

Double conical~

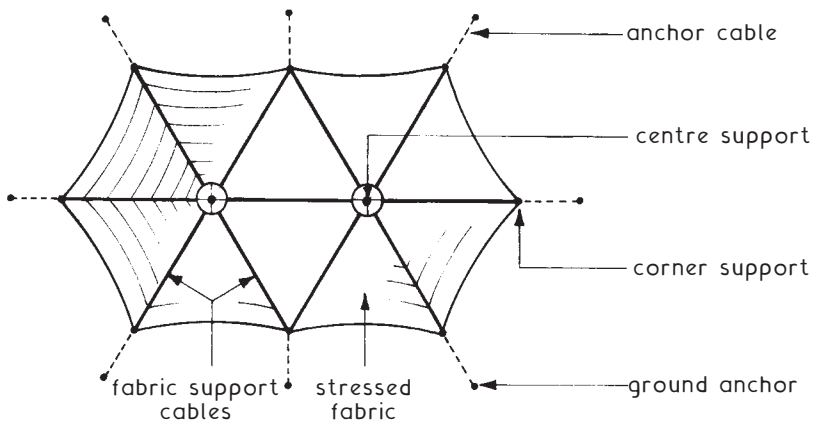

## Membrane Roof Structures

Simple support structure as viewed from the underside ~

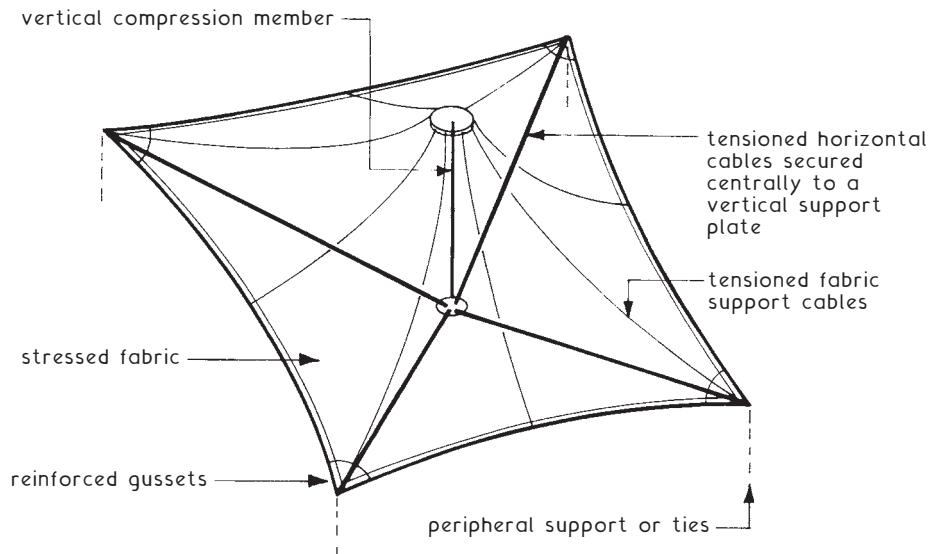

Fabric ~ has the advantages of requiring minimal support, opportunity for architectural expression in colour and geometry and a translucent quality that provides an outside feel inside, whilst combining shaded cover from the sun and shelter from rain. Applications are generally attachments as a feature to entrances and function areas in prominent buildings, notably sports venues, airports and convention centres.

Materials ~ historically, animal hides were the first materials used for tensile fabric structures, but more recently woven fibres of hemp, flax or other natural yarns have evolved as canvas. Contemporary synthetic materials have a plastic coating on a fibrous base. These include polyvinyl chloride (PVC) on polyester fibres, silicone on glass fibres and polytetrafluorethylene (PTFE) on glass fibres. Design life is difficult to estimate, as it will depend very much on type of exposure. Previous use of these materials would indicate that at least 20 years is anticipated, with an excess of 30 years being likely. Jointing can be by fusion welding of plastics, bonding with silicone adhesives and stitching with glass threads.

Rooflights ~ the useful penetration of daylight through the windows in external walls of buildings is from 6.000 to 9.000 depending on the height and size of the window. In buildings with spans over 18.000 side wall daylighting needs to be supplemented by artificial lighting or in the case of top floors or single-storey buildings by rooflights. The total maximum area of wall window openings and rooflights for the various purpose groups is set out in the Building Regulations with allowances for increased areas if double or triple glazing is used. In pitched roofs such as northlight and monitor roofs the rooflights are usually in the form of patent glazing (see Long Span Roofs on pages 671 and 672). In flat roof construction natural daylighting can be provided by one or more of the following methods:

1. Lantern lights - see page 697.
2. Lens lights - see page 697.
3. Dome, pyramid and similar rooflights - see page 698.

Patent Glazing ~ these are systems of steel or aluminium alloy glazing bars which span the distance to be glazed whilst giving continuous edge support to the glass. They can be used in the roof forms noted above as well as in pitched roofs with profiled coverings where the patent glazing bars are fixed above and below the profiled sheets - see next page.

Typical Patent Glazing Bar Sections ~

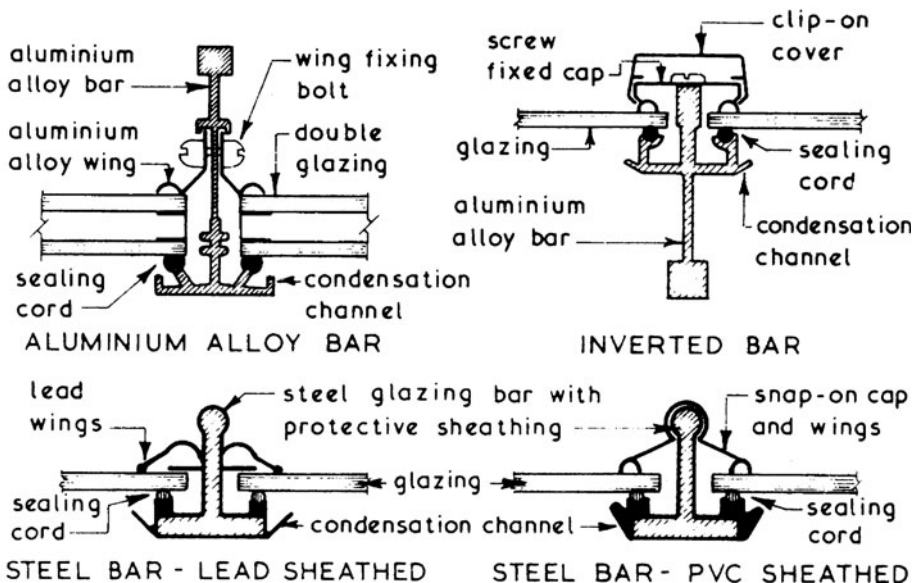

Typical Pitched Roof Patent Glazing Details ~

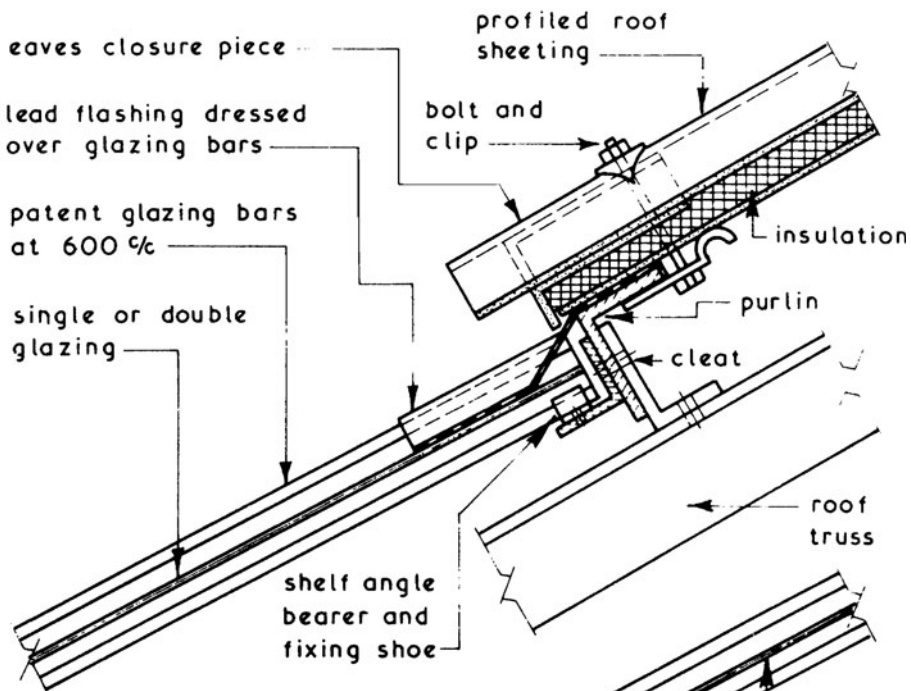

TOP CONNECTION

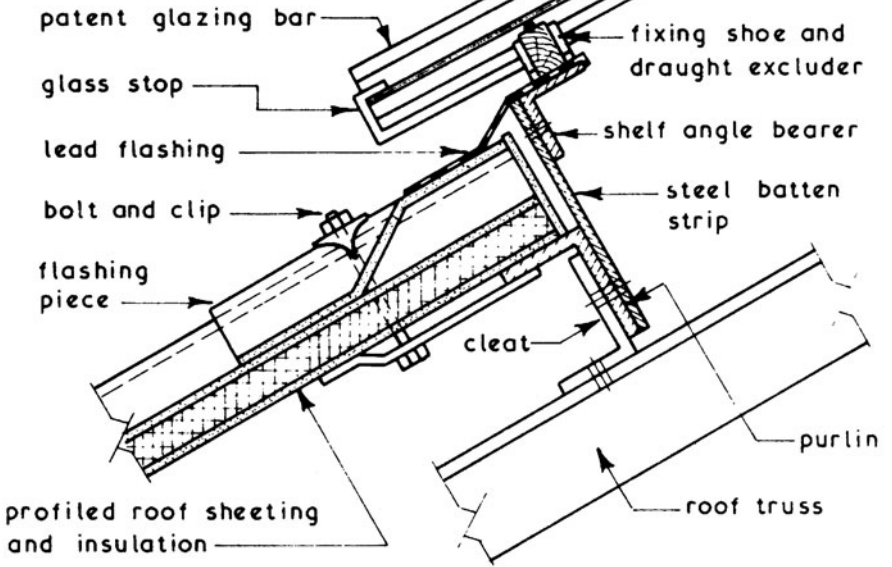

BOTTOM CONNECTION

Lantern Lights ~ these are a form of rooflight used in conjunction with flat roofs. They consist of glazed vertical sides and fully glazed pitched roof which is usually hipped at both ends. Part of the glazed upstand sides is usually formed as an opening light or alternatively glazed with louvres to provide a degree of controllable ventilation. They can be constructed of timber, metal or a combination of these two materials. Lantern lights in the context of new buildings have been generally superseded by the various forms of dome light (see next page).

Typical Lantern Light Details ~

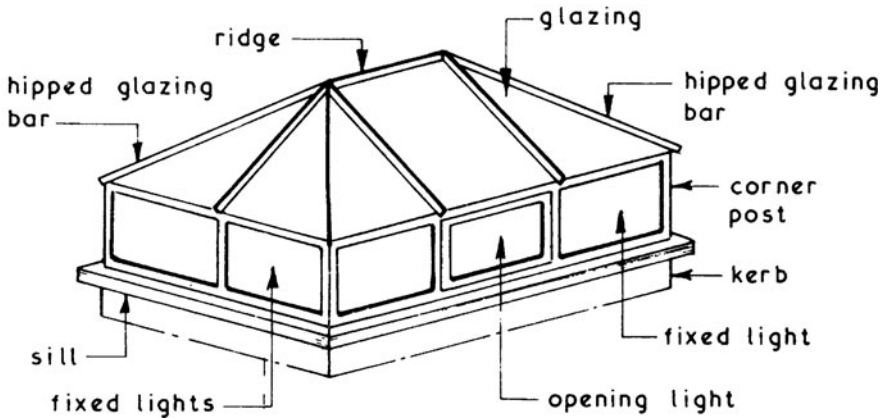

Lens Lights ~ these are small square or round blocks of translucent toughened glass especially designed for casting into concrete and are suitable for use in flat roofs and curved roofs such as barrel vaults. They can also be incorporated into precast concrete frames for inclusion in a cast in-situ roof.

Typical Details ~

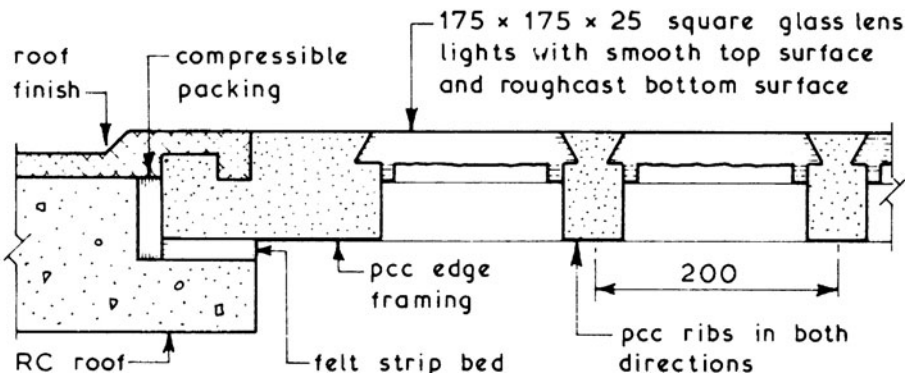

# Rooflights

Dome, Pyramid and Similar Rooflights ~ these are used in conjunction with flat roofs and may be framed or unframed. The glazing can be of glass or plastics such as polycarbonate, acrylic, PVC and glass fibre reinforced polyester resin (grp). The whole component is fixed to a kerb and may have a raising piece containing hit and miss ventilators, louvres or flaps for controllable ventilation purposes.

Typical Details ~

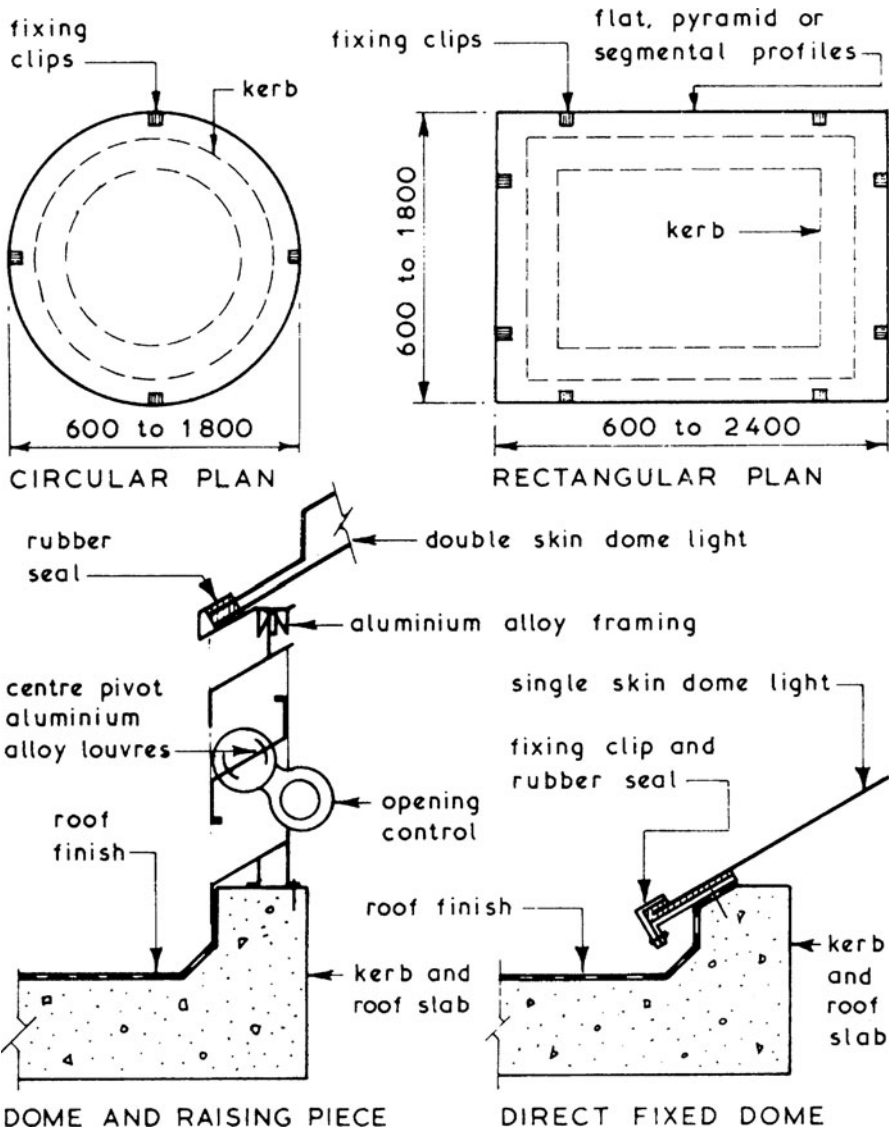

## Non-load-bearing Brick Panel Walls

Non-load-bearing Brick Panel Walls ~ these are used in conjunction with framed structures as an infill between the beams and columns. They are constructed in the same manner as ordinary brick walls with the openings being formed by traditional methods.

Basic requirements:

1. To be adequately supported by and tied to the structural frame.
2. Have sufficient strength to support own self-weight plus any attached finishes and imposed loads such as wind pressures.
3. Provide the necessary resistance to penetration by the natural elements.
4. Provide the required degree of thermal insulation, sound insulation and fire resistance.
5. Have sufficient durability to reduce maintenance costs to a minimum.
6. Provide for movements due to moisture and thermal expansion of the panel and for contraction of the frame.

Typical Details ~

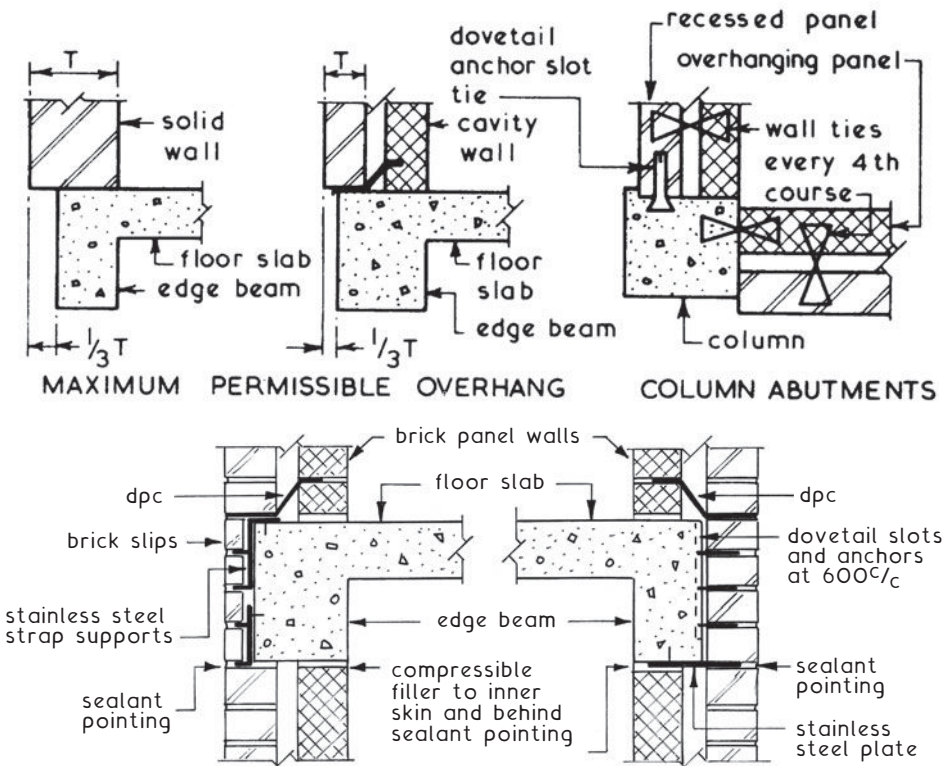



## Brickwork Cladding Support System

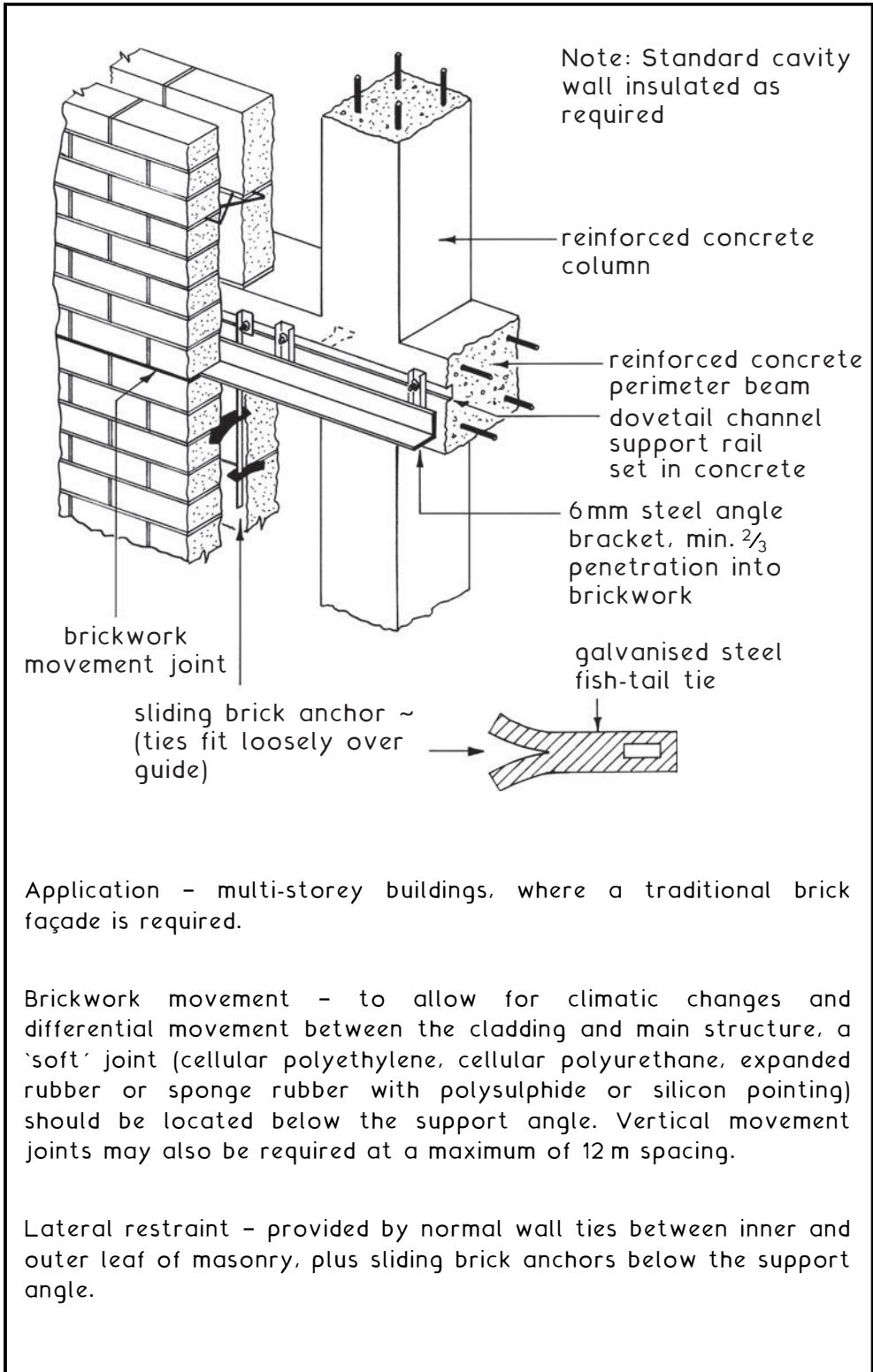

Infill Panel Walls ~ these can be used between the framing members of a building to provide the cladding and division between the internal and external environments and are distinct from claddings and facing:

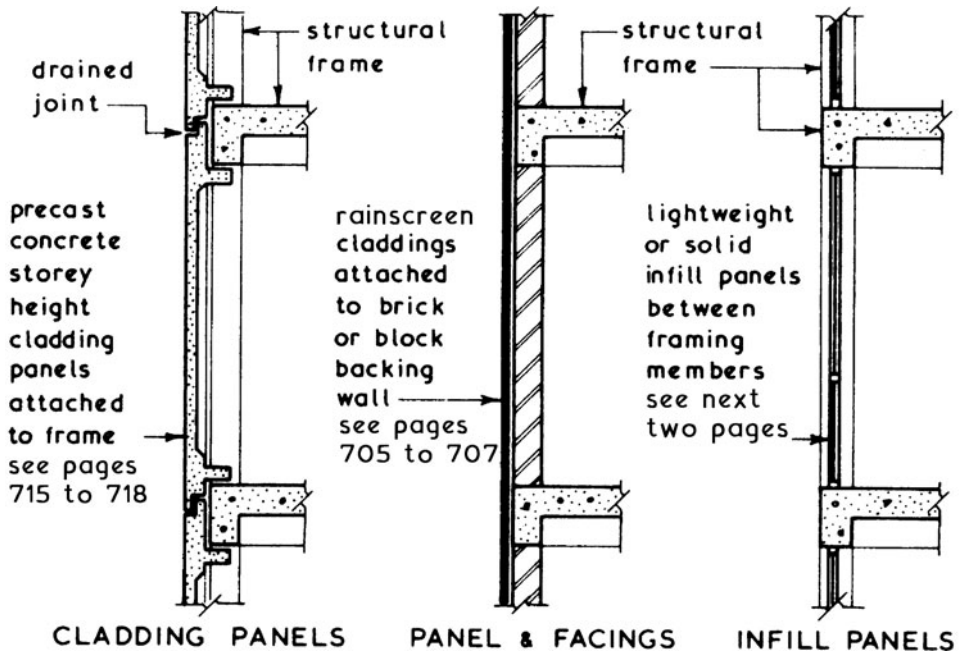

Functional Requirements ~ all forms of infill panel should be designed and constructed to fulfil the following functional requirements:

1. Self-supporting between structural framing members.
2. Provide resistance to the penetration of the elements.
3. Provide resistance to positive and negative wind pressures.
4. Give the required degree of thermal insulation.
5. Give the required degree of sound insulation.
6. Give the required degree of fire resistance.
7. Have sufficient openings to provide the required amount of natural ventilation.
8. Have sufficient glazed area to fulfil the natural daylight and vision out requirements.
9. Be economical in the context of construction and maintenance.
10. Provide for any differential movements between panel and structural frame.

# Infill Panel Walls

Brick Infill Panels ~ these can be constructed in a solid or cavity format, the latter usually having an inner skin of blockwork to increase the thermal insulation properties of the panel. All the fundamental construction processes and detail of solid and cavity walls (bonding, lintels over openings, wall ties, damp-proof courses, etc.) apply equally to infill panel walls. The infill panel walls can be tied to the columns by means of wall ties cast into the columns at 300 mm centres or located in cast-in dovetail anchor slots. The head of every infill panel should have a compressible joint to allow for any differential movements between the frame and panel.

## Typical Details

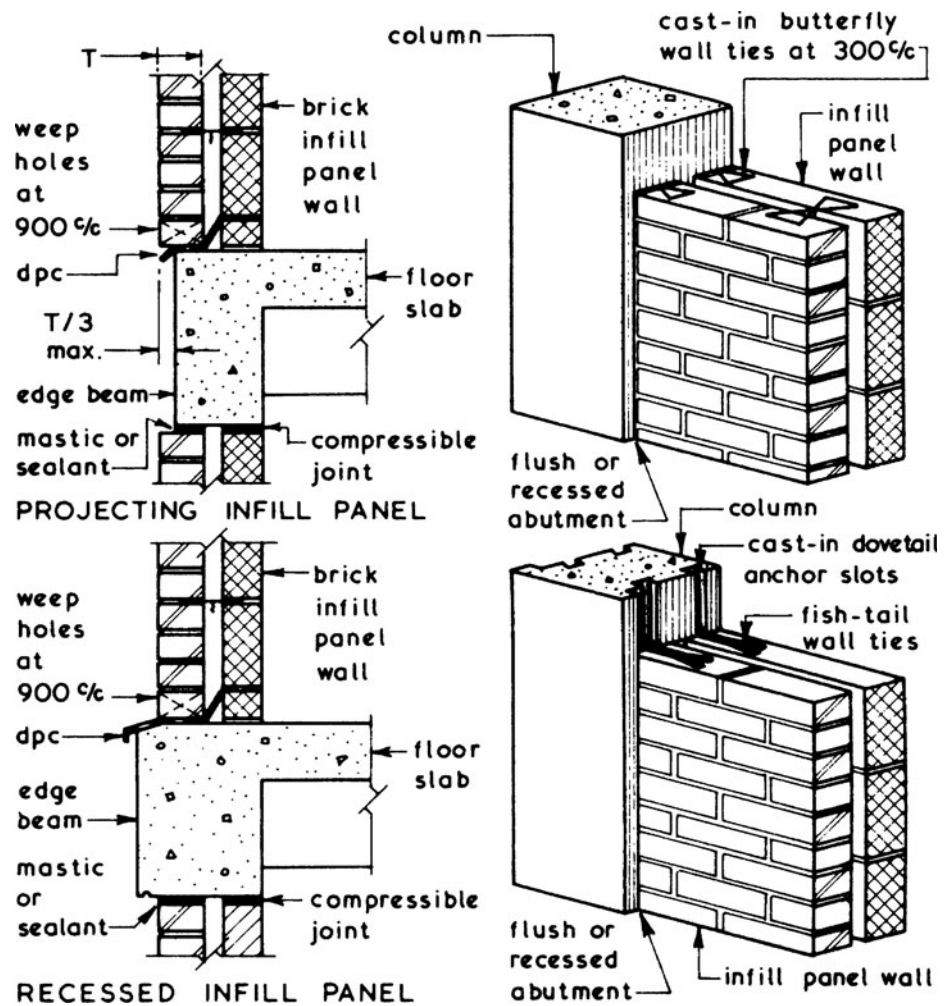

Lightweight Infill Panels ~ these can be constructed from a wide variety or combination of materials such as timber, metals and plastics into which single or double glazing can be fitted. If solid panels are to be used below a transom they are usually of a composite or sandwich construction to provide the required sound insulation, thermal insulation and fire resistance properties.

Typical Example ~

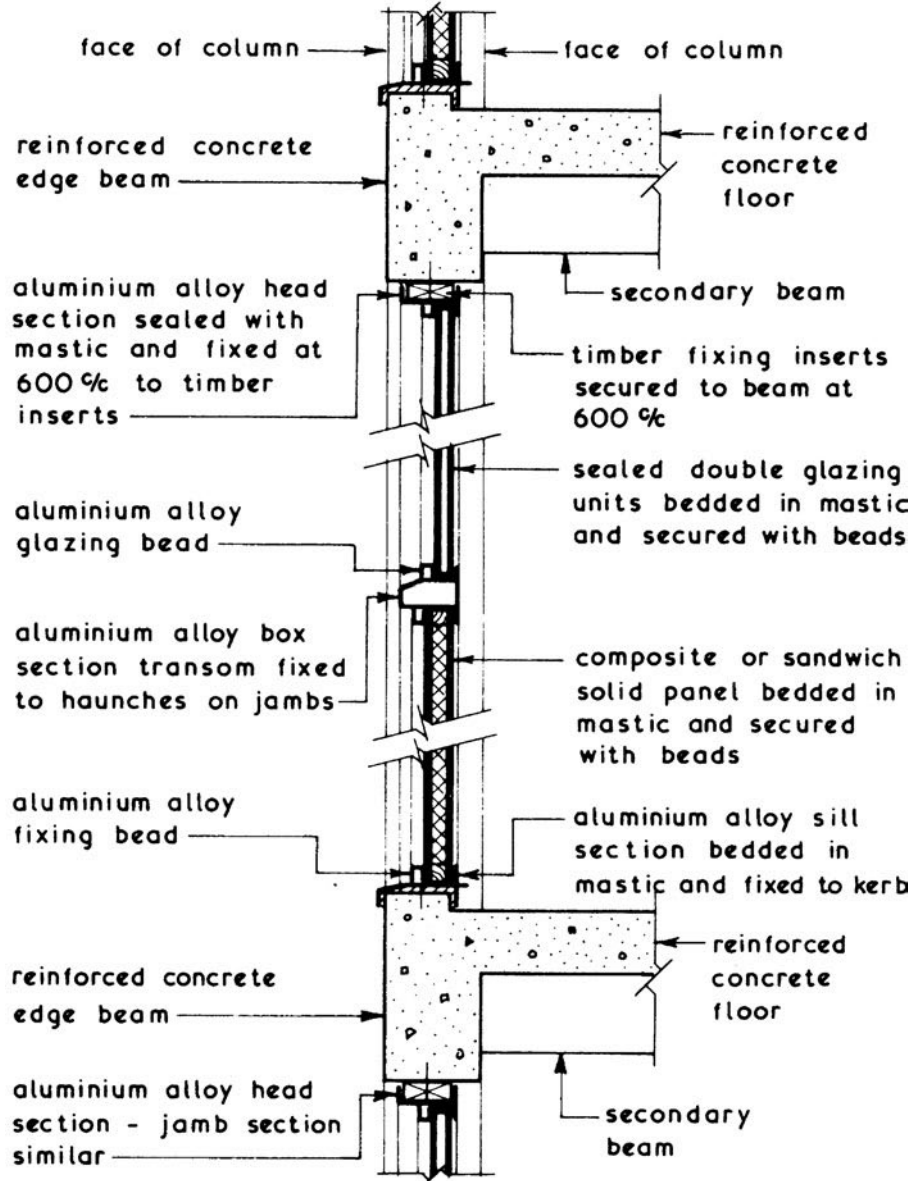

# Infill Panel Walls

Lightweight Infill Panels ~ these can be fixed between the structural horizontal and vertical members of the frame or fixed to the face of either the columns or beams to give a grid, horizontal or vertical emphasis to the façade thus:

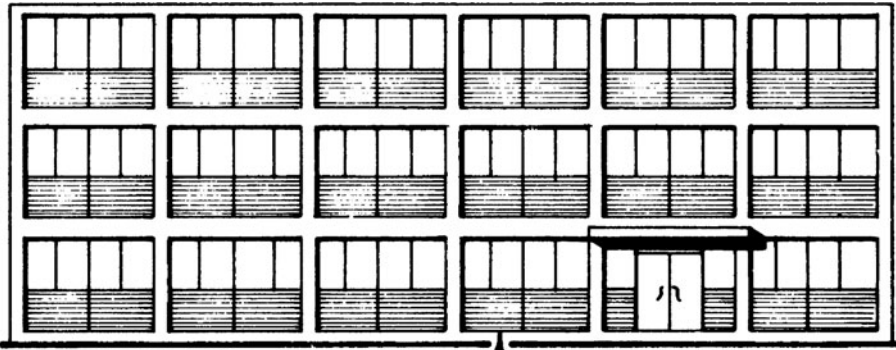

GRID OR FRAME EMPHASIS

panels fixed between columns and beams

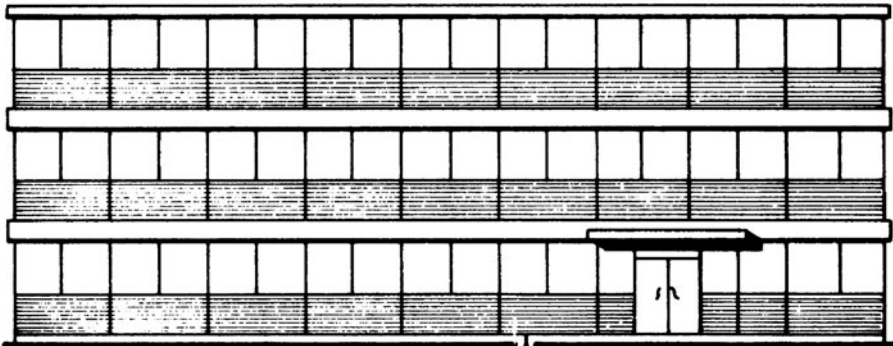

HORIZONTAL EMPHASIS

panels fixed between beams and over columns

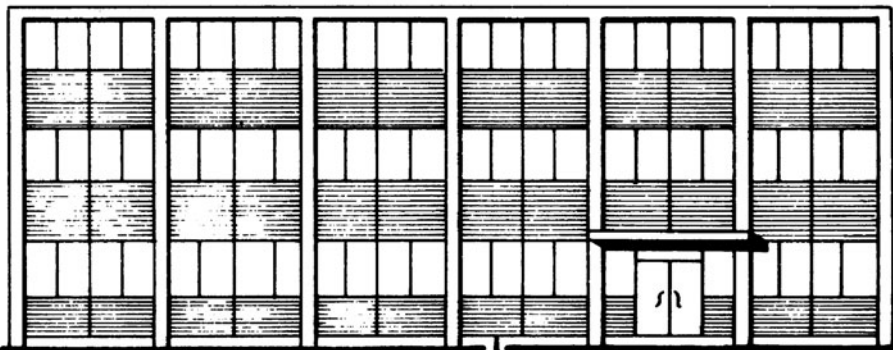

VERTICAL EMPHASIS

panels fixed between columns and over beams

Rainscreen Cladding ~ a surface finish produced by overcladding the external walls of new construction, or as a decorative façade and insulation enhancement to the external walls of existing construction. This concept provides an inexpensive *loose-fit* weather resistant layer. It is simple to replace to suit changes in occupancy, corporate image, client tastes, new material innovations and design changes in the appearance of buildings. Sustainability objectives are satisfied by re-use and refurbishment instead of demolition and rebuilding. Existing buildings can be seamlessly extended with uniformity of finish.

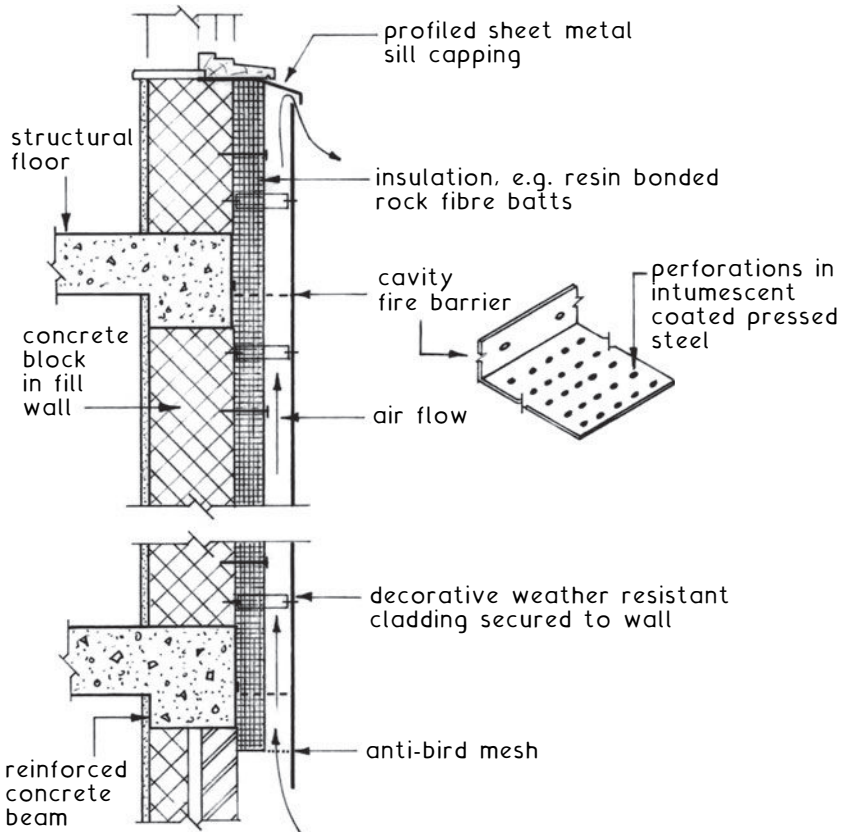

## Principle Features ~

- \* Weather-proof outer layer includes plastic laminates, fibre-cement, ceramics, aluminium, enamelled steel and various stone effects.
- \* Decorative finish.
- \* Support frame attached to structural wall.
- \* Ventilated and drained cavity behind cladding.
- \* Facility for sound and thermal insulation.
- \* *Loose-fit* simple and economic for ease of replacement.

# RSC - Timber Support Frame

Standard sawn treated softwood sections of 38 mm minimum dimension.

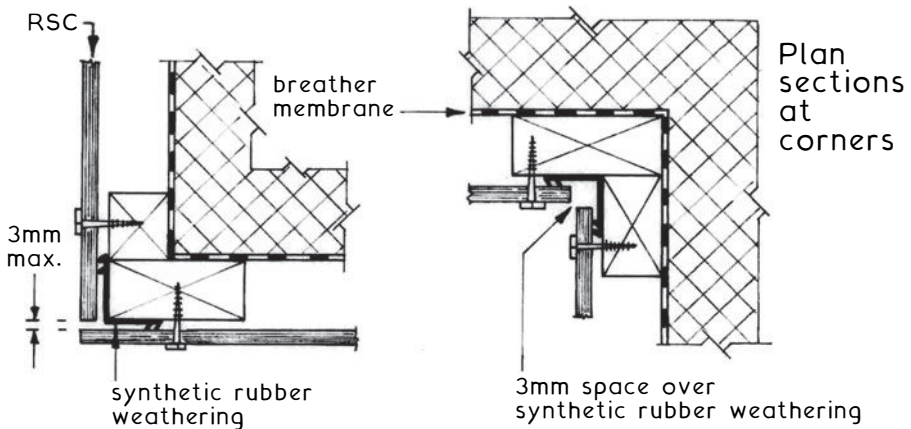
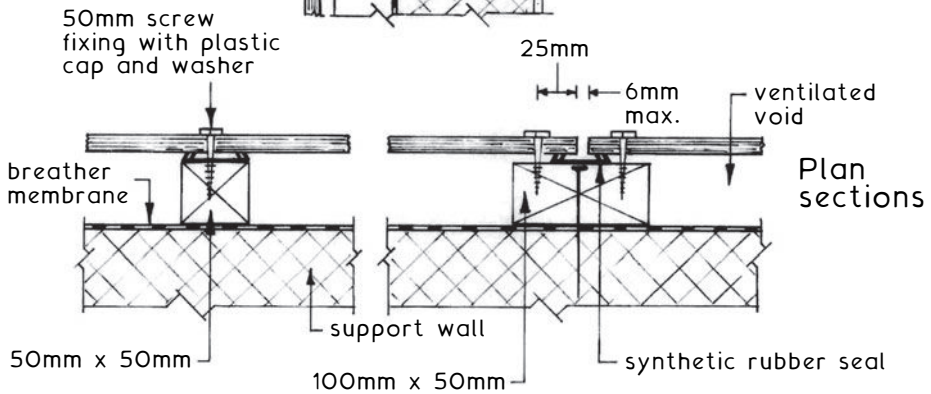
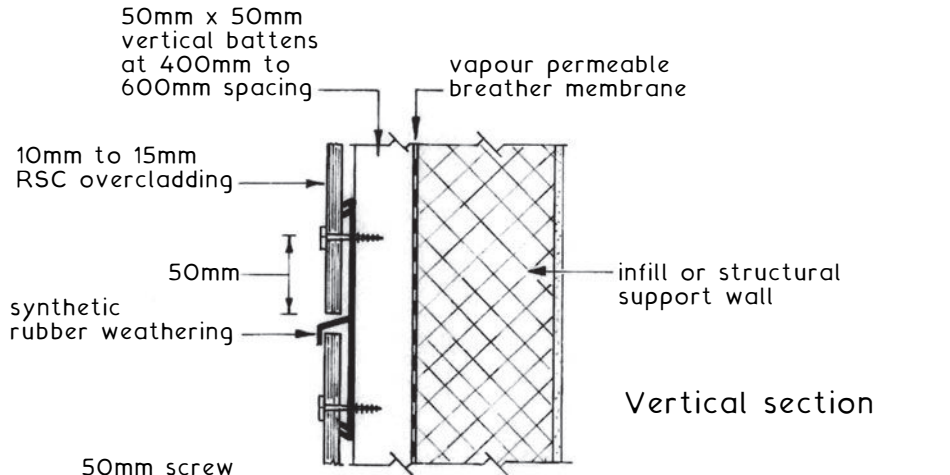

Note: Timber support battens to be pre-treated with waterproof preservative.

Aluminium alloy standard profile sections with extendable support brackets.

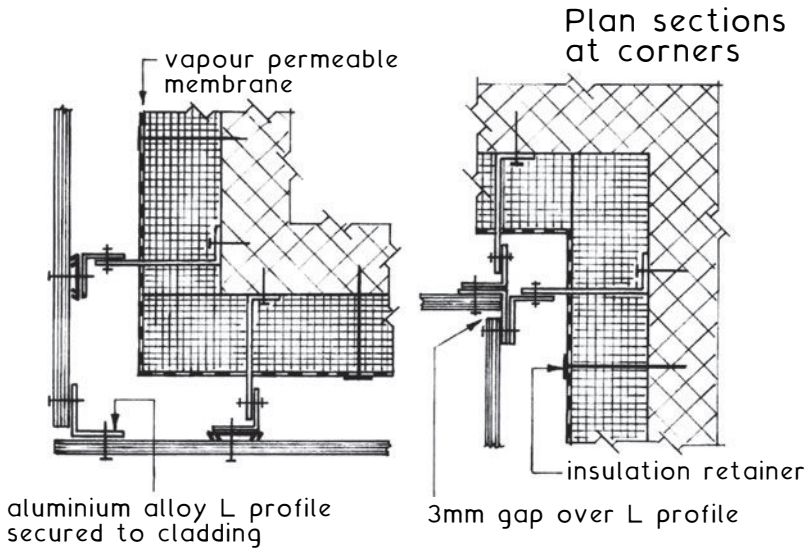
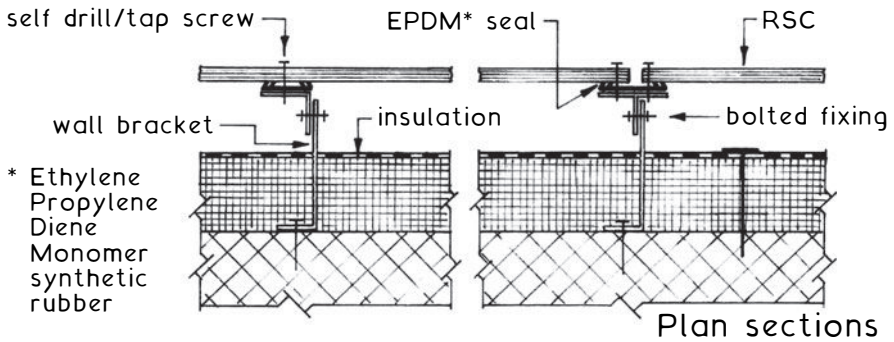
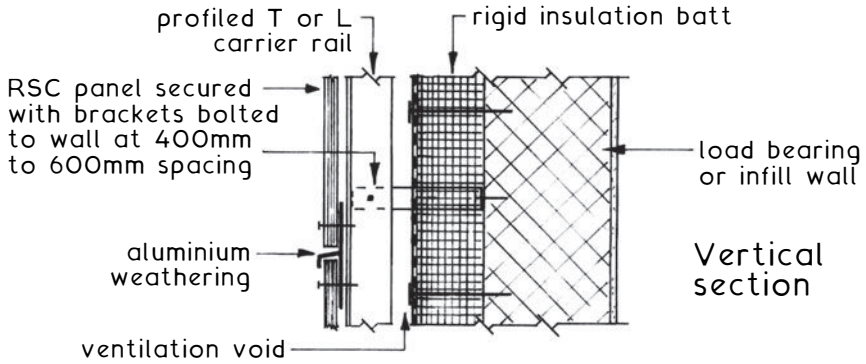

Note: RSC materials should satisfy tests for fire propagation and surface spread of flame, ref. BS 476-6 and 7 respectively.



## Structural Sealant Glazed Cladding

Glazed façades have been associated with hi-tech architecture since the 1970s. The increasing use of this type of cladding is largely due to developments in toughened glass and improved qualities of elastomeric silicone sealants. The properties of the latter must incorporate a resilience to varying atmospheric conditions as well as the facility to absorb structural movement without loss of adhesion.

Systems - two edge and four edge.

The two edge system relies on conventional glazing beads/fixings to the head and sill parts of a frame, with sides silicone bonded to mullions and styles.

The four edge system relies entirely on structural adhesion, using silicone bonding between glazing and support frame - see details.

Structural glazing, as shown on this and the next page, is in principle a type of curtain walling. Due to its unique appearance it is usual to consider full glazing of the building façade as a separate design and construction concept.

BS EN 13830: Curtain walling. Product standard; defines curtain walling as an external vertical building enclosure produced by elements mainly of metal, timber or plastic. Glass as a primary material is excluded.

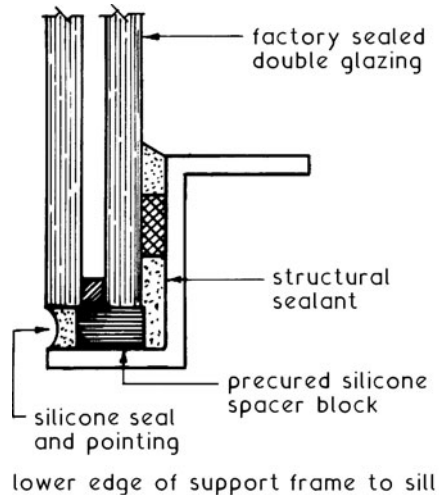
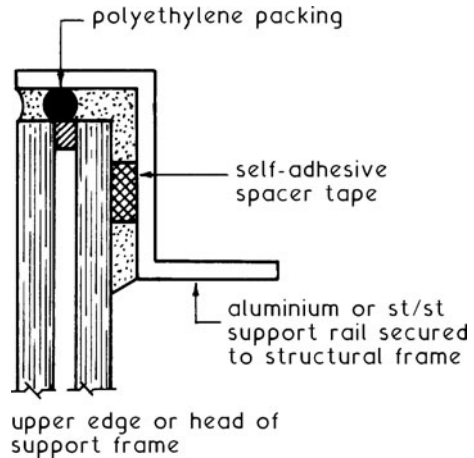

Note: Sides of frame as head.

Structural glazing is otherwise known as frameless glazing. It is a system of toughened glass cladding without the visual impact of surface fixings and supporting components. Unlike curtain walling, the self-weight of the glass and wind loads are carried by the glass itself and transferred to a subsidiary lightweight support structure behind the glazing.

## Assembly Principles ~

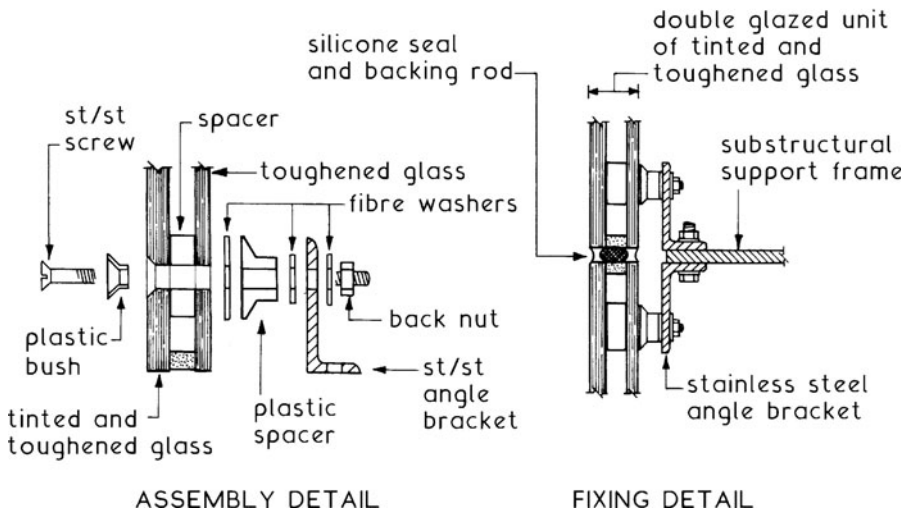
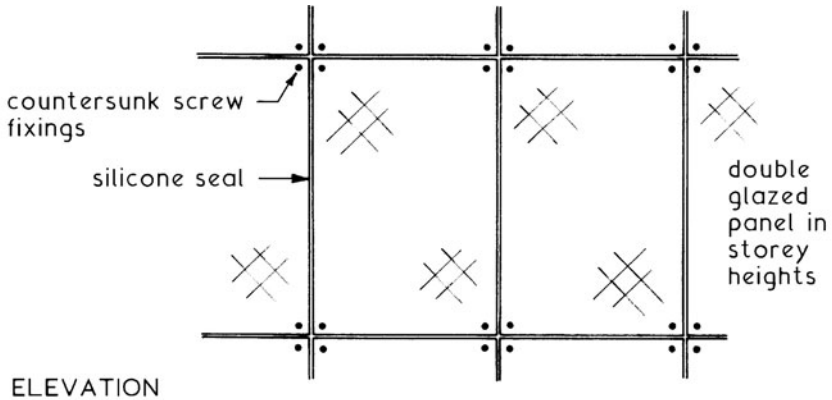

# Curtain Walling

Curtain Walling ~ this is a form of light weight non-load bearing external cladding which forms a complete envelope or sheath around the structural frame. In low rise structures the curtain wall framing could be of timber or patent glazing but in the usual high rise context, box or solid members of steel or aluminium alloy are normally employed.

Basic Requirements for Curtain Walls:

1. Provide the necessary resistance to penetration by the elements.
2. Have sufficient strength to carry own self-weight and provide resistance to both positive and negative wind pressures.
3. Provide required degree of fire resistance - glazed areas are classified in the Building Regulations as unprotected areas; therefore any required fire resistance must be obtained from the infill or undersill panels and any backing wall or beam.
4. Be easy to assemble, fix and maintain.
5. Provide the required degree of sound and thermal insulation.
6. Provide for thermal and structural movements.

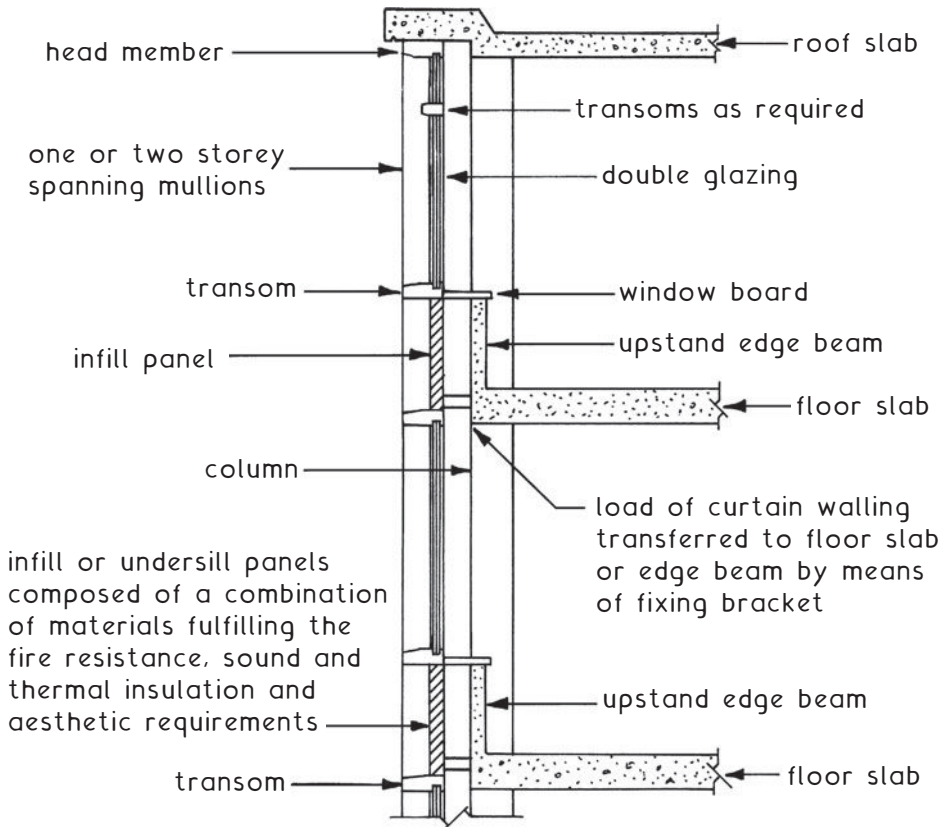

## Typical Curtain Walling Details

Principles ~

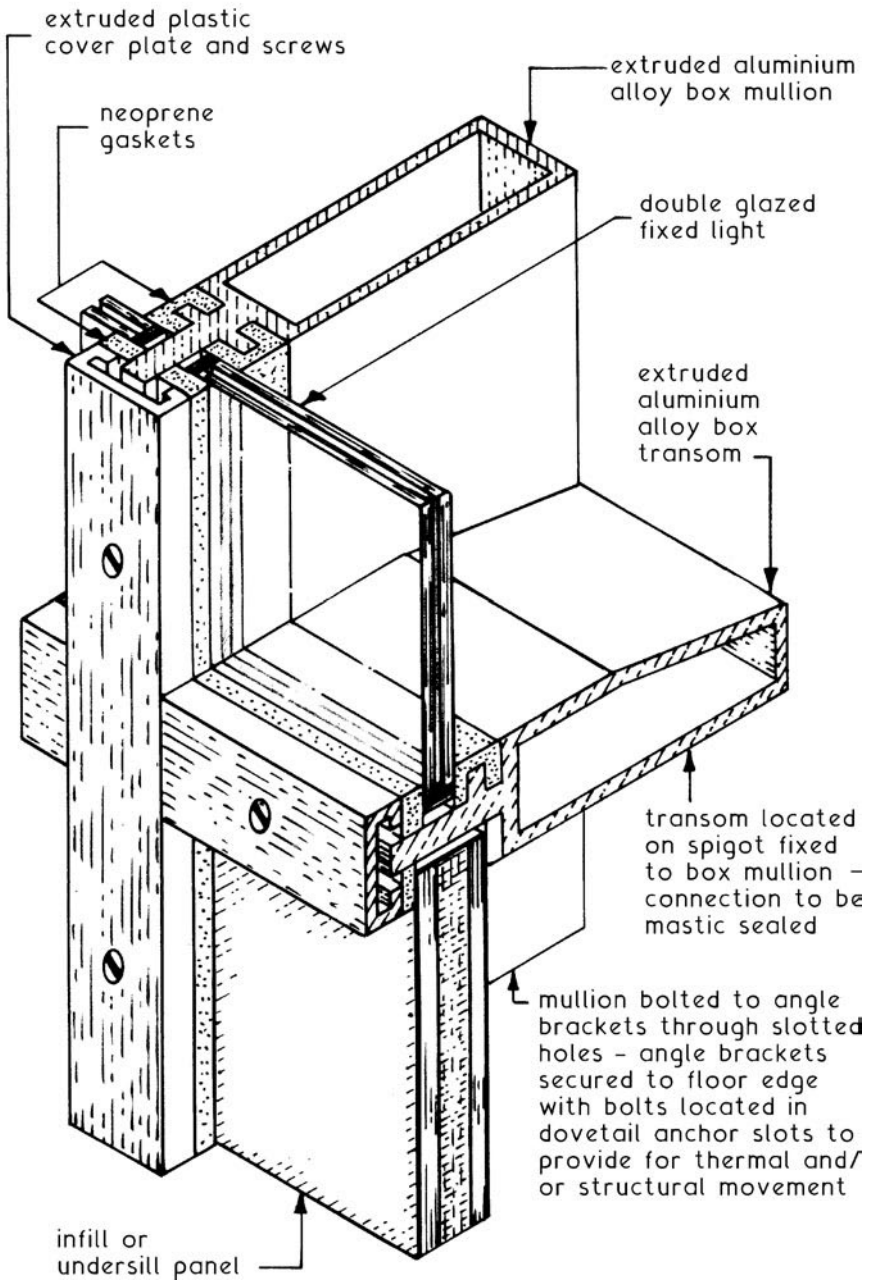

# Curtain Walling

Fixing Curtain Walling to the Structure ~ in curtain walling systems it is the main vertical component or mullion which carries the loads and transfers them to the structural frame at every or alternate floor levels depending on the spanning ability of the mullion. At each fixing point the load must be transferred and an allowance made for thermal expansion and differential movement between the structural frame and curtain walling. The usual method employed is slotted bolt fixings.

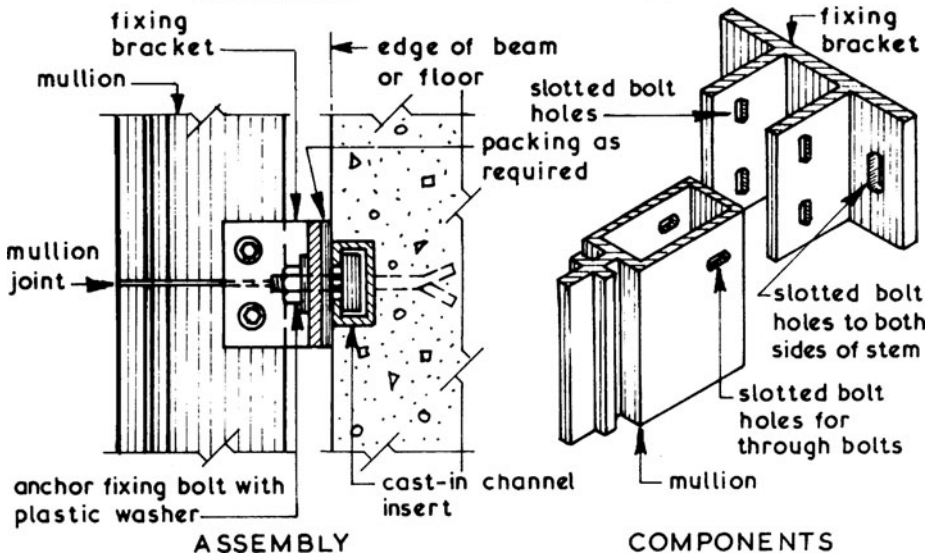
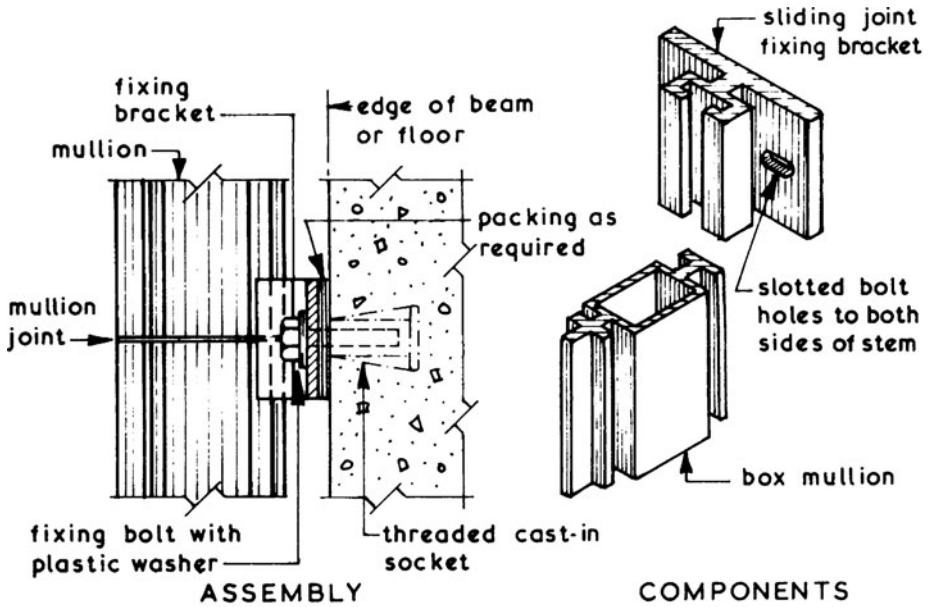

## Curtain Wall – Over-cladding in Glass

Re-cladding existing framed buildings has become an economical alternative to complete demolition and rebuilding. This may be justified when a building has a change of use or it is in need of an image upgrade. Current energy conservation measures can also be achieved by the redressing of older buildings.

Typical section through an existing structural floor slab with a replacement system attached ~

### Framing Detail

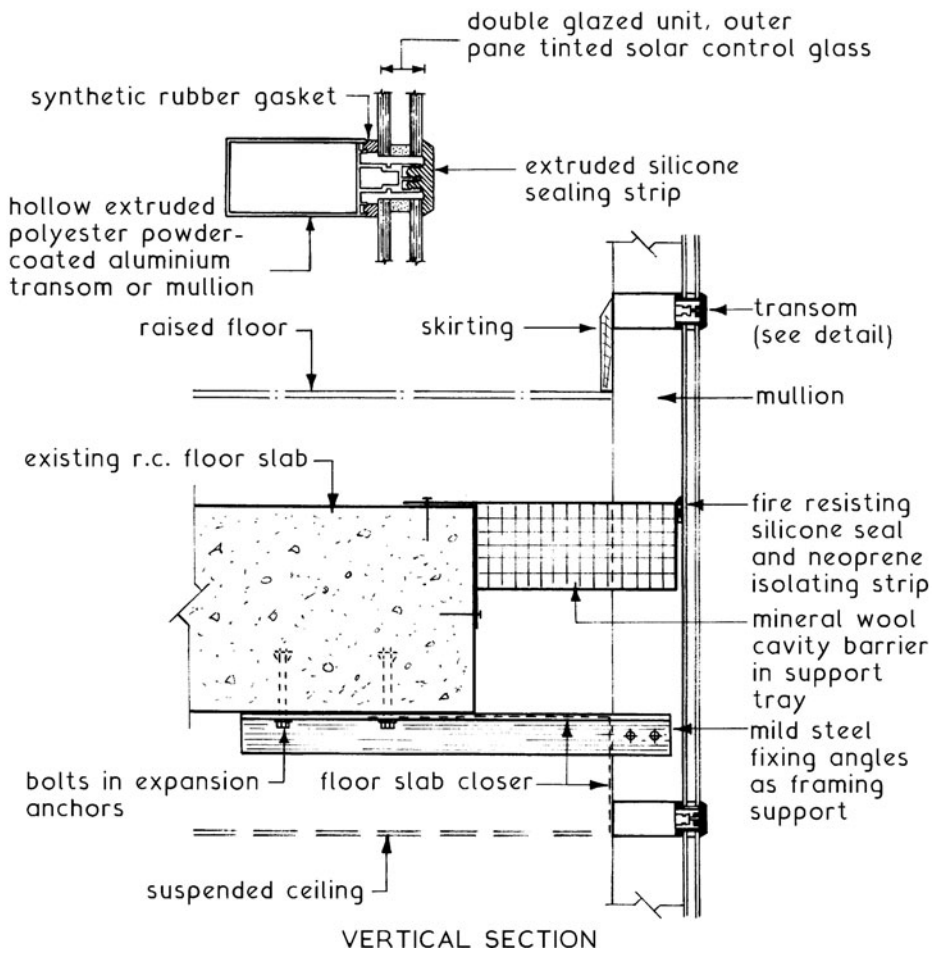

## Concrete Claddings – Load Bearing

Load bearing Concrete Panels ~ this form of construction uses storey height load bearing precast reinforced concrete perimeter panels. The width and depth of the panels is governed by the load(s) to be carried, the height and exposure of the building. Panels can be plain or fenestrated providing the latter leaves sufficient concrete to transmit the load(s) around the opening. The cladding panels, being structural, eliminate the need for perimeter columns and beams and provide an internal surface ready to receive insulation, attached services and decorations. In the context of design these structures must be formed in such a manner that should a single member be removed by an internal explosion, wind pressure or similar force, progressive or structural collapse will not occur, the minimum requirements being set out in Part A of the Building Regulations. Load bearing concrete panel construction can be a cost effective method of building.

Typical Details ~

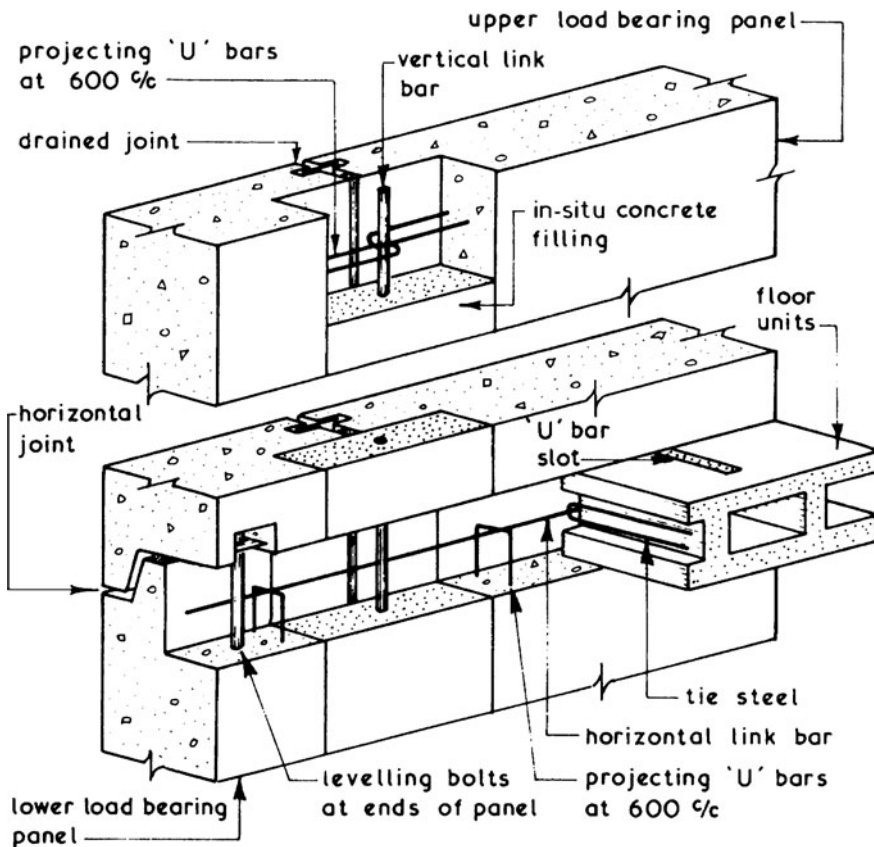

Concrete Cladding Panels ~ these are usually of reinforced precast concrete to an undersill or storey height format, the former being sometimes called apron panels. All precast concrete cladding panels should be designed and installed to fulfil the following functions:

1. Self-supporting between framing members.
2. Provide resistance to penetration by the natural elements.
3. Resist both positive and negative wind pressures.
4. Provide required degree of fire resistance.
5. Provide required degree of thermal insulation by having the insulating material incorporated within the body of the cladding or alternatively allow the cladding to act as the outer leaf of cavity wall panel.
6. Provide required degree of sound insulation.

Undersill or Apron Cladding Panels ~ these are designed to span from column to column and provide a seating for the windows located above. Levelling is usually carried out by wedging and packing from the lower edge before being fixed with grouted dowels.

Typical Details ~

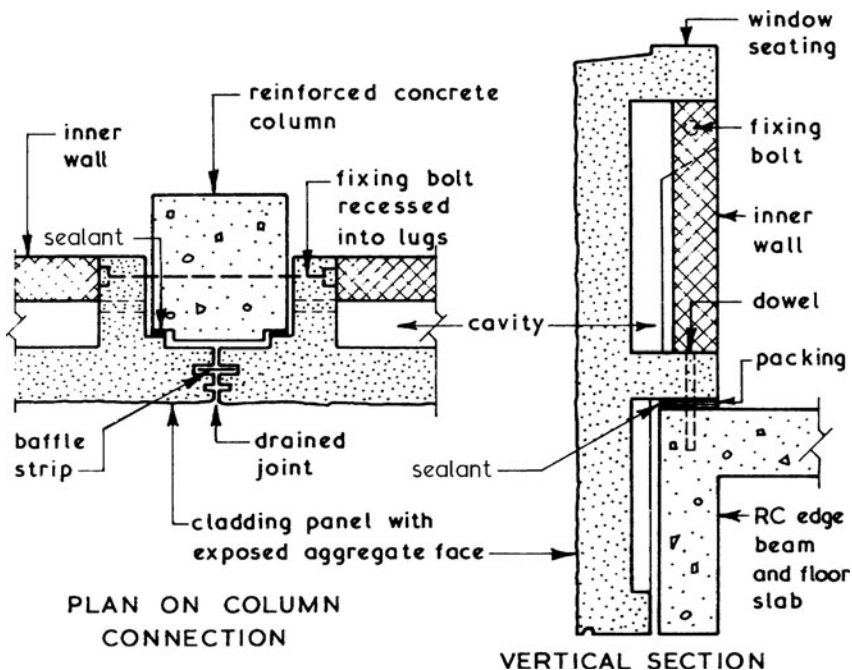



# Concrete Cladding – Storey Height

Storey Height Cladding Panels ~ these are designed to span vertically from beam to beam and can be fenestrated if required. Levelling is usually carried out by wedging and packing from floor level before being fixed by bolts or grouted dowels.

Typical Details ~

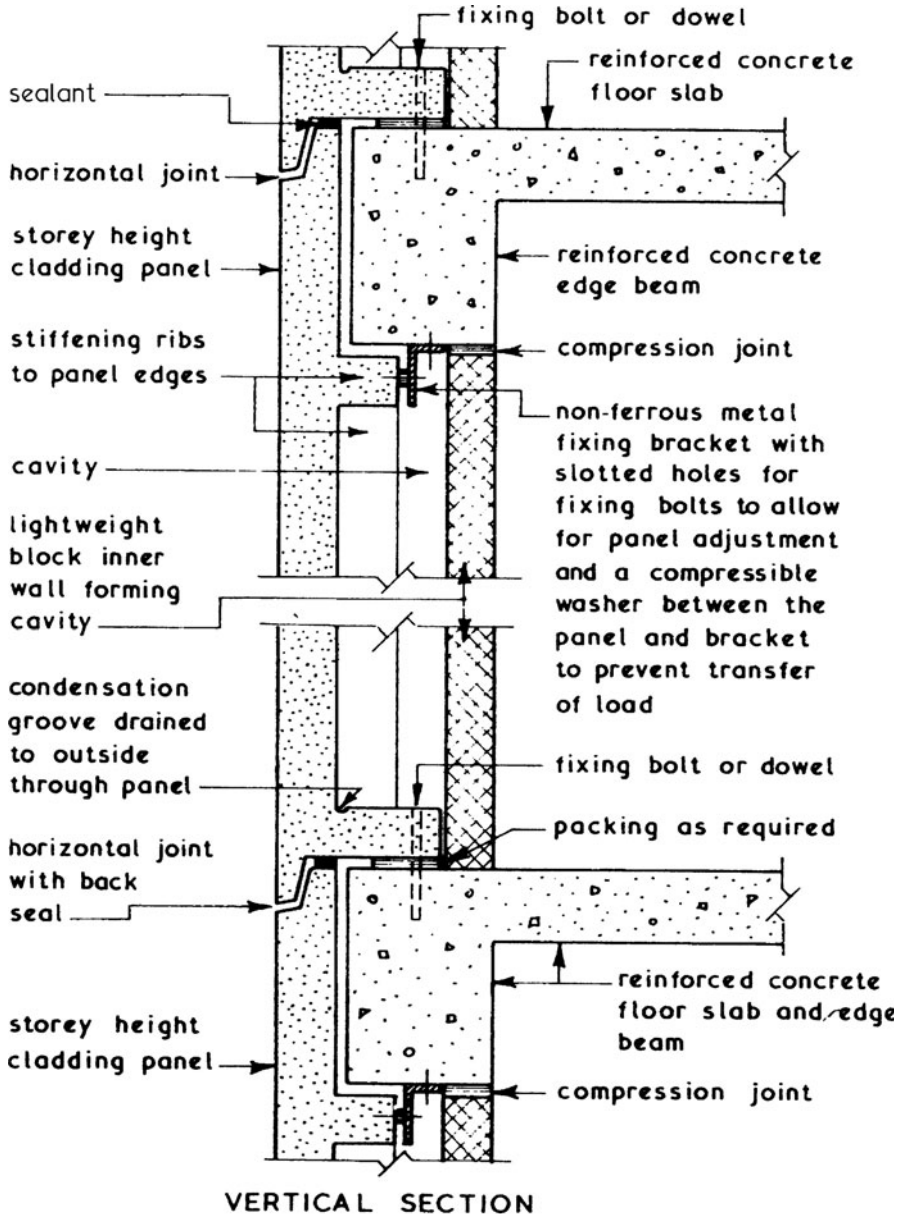

Single Stage ~ the application of a compressible filling material and a weatherproofing sealant between adjacent cladding panels. This may be adequate for relatively small areas and where exposure to thermal or structural movement is limited. Elsewhere, in order to accommodate extremes of thermal movement between exposed claddings, the use of only a sealant and filler would require an over-frequency of joints or over-wide joints that could slump or fracture.

Two Stage ~ otherwise known as open drained joints. The preferred choice as there is a greater facility to absorb movement. Drained joints to cladding panels comprise a sealant to the inside or back of the joint and a baffle to the front, both separated by an air seal.

Comparison of single- and two-stage jointing principles ~

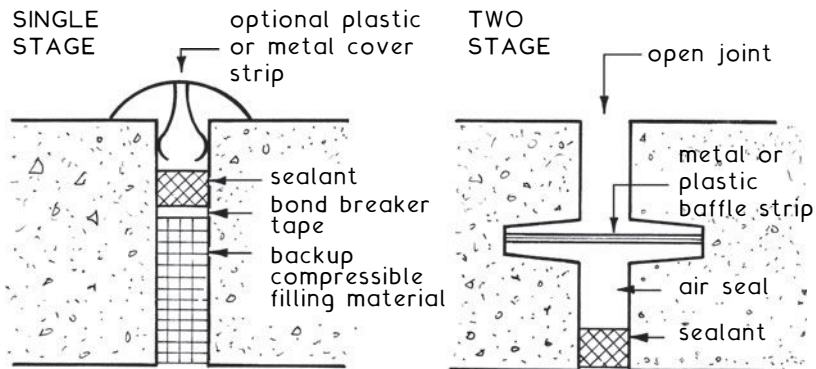

Plan views

Typical coefficients of linear thermal expansion ( $10^{-6}\text{m/mK}$ ) ~  
 Dense concrete aggregate 14, lightweight concrete aggregate 10.

Ref. BS 6093: Design of joints and jointing in building construction.

## Concrete Claddings – Drained Joint Intersection

Typical weathering detail ~

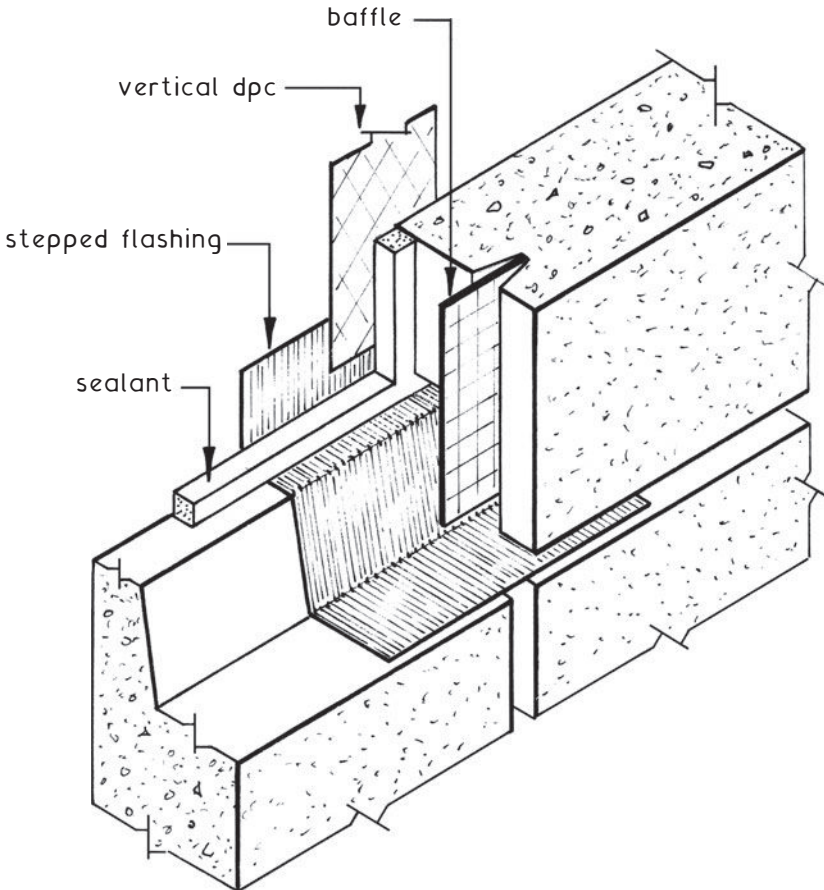

Where the horizontal lapped joint between upper and lower cladding panels coincides with the vertical open drained joint, a stepped apron flashing is required to weather the intersection. Lead is the natural choice for this, but reinforced synthetic rubber or reinforced plastic sheet may be preferred to avoid possible lead oxide staining over the panel surface.

Baffle material is traditionally of non-ferrous metal such as copper, but like lead this can cause staining to the surface. Neoprene, butyl rubber or PVC are alternatives.

Gasket ~ an alternative to using mastic or sealant to close the gap between two cladding panels. They are used specifically where movements or joint widths are greater than could be accommodated by sealants. For this purpose a gasket is defined in BS 6093 as 'flexible, generally elastic, preformed material that constitutes a seal when compressed'.

Location and Fit ~ as shown on the next page, a recess is provided in at least one of the two adjacent claddings. To be effective contact surfaces must be clean and free of imperfections for a gasket to exert pressure on adjacent surfaces and to maintain this during all conditions of exposure. To achieve this, greater dimensional accuracy in manufacture and assembly of components is necessary relative to other sealing systems.

Profile ~ solid or hollow extrusions in a variety of shapes. Generally non-structural but vulcanised polychloroprene rubber can be used if a structural specification is required.

Materials (non-structural) ~ synthetic rubber including neoprene, silicone, ethylene propylene diene monomer (EPDM) and thermoplastic rubber (TPR). These materials are very durable with excellent resistance to compression, heat, water, ultra-violet light, ozone, ageing, abrasion and chemical cleaning agents such as formaldehyde. They also have exceptional elastic memory, i.e. will resume original shape after stressing. Polyvinyl chloride (PVC) and similar plastics can also be used but they will need protection from the effects of direct sunlight.

Refs.:

BS 4255-1: Rubber used in preformed gaskets for weather exclusion from buildings. Specification for non-cellular gaskets.

BS 6093: Design of joints and jointing in building construction. Guide.

# Concrete Claddings – Gasket Joint Types

Non-structural gasket types (shown plan view) ~

HOLLOW/TUBULAR (cast into concrete during manufacture)

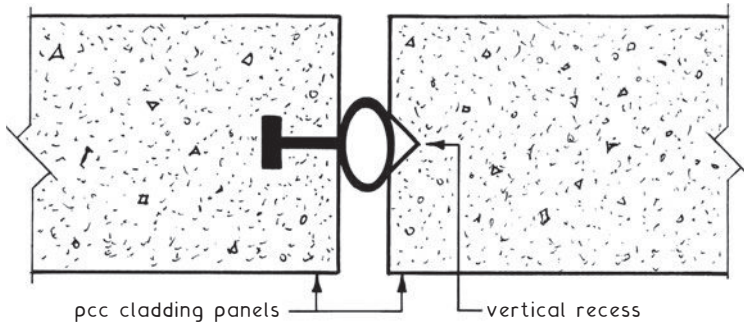

SOLID DOUBLE SPLAY (fitted on site during assembly)

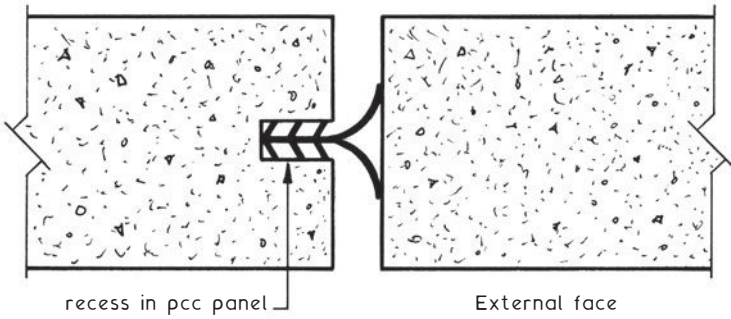

SOLID CRUCIFORM

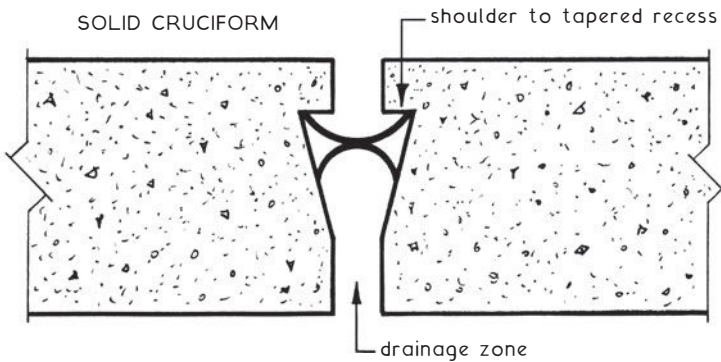

Gaskets have other applications to construction. See Double Glazing, Triple Glazing and Curtain Walling.

Concrete Surface Finishes ~ it is not easy to produce a concrete surface with a smooth finish of uniform colour direct from the mould or formwork since the colour of the concrete can be affected by the cement and fine aggregate used. The concrete surface texture can be affected by the aggregate grading, cement content, water content, degree of compaction, pin holes caused by entrapped air and rough patches caused by adhesion to parts of the formworks. Complete control over the above mentioned causes is difficult under ideal factory conditions and almost impossible under normal site conditions. The use of textured and applied finishes has therefore the primary function of improving the appearance of the concrete surface and in some cases it will help to restrict the amount of water which reaches a vertical joint.

Casting ~ concrete components can usually be cast in-situ or precast in moulds. Obtaining a surface finish to concrete cast in-situ is usually carried out against a vertical face, whereas precast concrete components can be cast horizontally and treated on either upper or lower mould face. Apart from a plain surface concrete the other main options are:

1. Textured and profiled surfaces.
2. Tooled finishes.
3. Cast-on finishes (see next page).
4. Exposed aggregate finishes (see next page).

Textured and Profiled Surfaces ~ these can be produced on the upper surface of a horizontal casting by rolling, tamping, brushing and sawing techniques but variations in colour are difficult to avoid. Textured and profiled surfaces can be produced on the lower face of a horizontal casting by using suitable mould linings.

Tooled Finishes ~ the surface of hardened concrete can be tooled by bush hammering, point tooling and grinding. Bush hammering and point tooling can be carried out by using an electric or pneumatic hammer on concrete which is at least three weeks old provided gravel aggregates have not been used, since these tend to shatter leaving surface pits. Tooling up to the arris could cause spalling; therefore a 10 mm wide edge margin should be left untooled. Grinding the hardened concrete consists of smoothing the surface with a rotary carborundum disc which may have an integral water feed. Grinding is a suitable treatment for concrete containing the softer aggregates such as limestone.

## Concrete Surface Finishes (2)

Cast-on Finishes ~ these finishes include split blocks, bricks, stone, tiles and mosaic. Cast-on finishes to the upper surface of a horizontal casting are not recommended although such finishes could be bedded onto the fresh concrete. Lower face treatment is by laying the materials with sealed or grouted joints onto the base of mould or alternatively the materials to be cast-on may be located in a sand bed spread over the base of the mould.

Exposed Aggregate Finishes ~ attractive effects can be obtained by removing the skin of hardened cement paste or surface matrix, which forms on the surface of concrete, to expose the aggregate. The methods which can be employed differ with the casting position.

Horizontal Casting - treatment to the upper face can consist of spraying with water and brushing some two hours after casting, trowelling aggregate into the fresh concrete surface or by using the felt-float method. This method consists of trowelling 10mm of dry mix fine concrete onto the fresh concrete surface and using the felt pad to pick up the cement and fine particles from the surface leaving a clean exposed aggregate finish.

Treatment to the lower face can consist of applying a retarder to the base of the mould so that the partially set surface matrix can be removed by water and/or brushing as soon as the castings are removed from the moulds. When special face aggregates are used the sand bed method could be employed.

Vertical Casting - exposed aggregate finishes to the vertical faces can be obtained by tooling the hardened concrete or they can be cast-on by the aggregate transfer process. This consists of sticking the selected aggregate onto the rough side of pegboard sheets with a mixture of water-soluble cellulose compounds and sand fillers. The cream-like mixture is spread evenly over the surface of the pegboard to a depth of one-third the aggregate size and the aggregate sprinkled or placed evenly over the surface before being lightly tamped into the adhesive. The prepared board is then set aside for 36 hours to set before being used as a liner to the formwork or mould. The liner is used in conjunction with a loose plywood or hardboard baffle placed against the face of the aggregate. The baffle board is removed as the concrete is being placed.



Special Effects ~ coloured cements and variations in aggregate content can be used with, or as a separate effect from, the surface treatments considered on the previous two pages. Two other special effect concretes that have been used extensively are:

- Granolithic
- Terrazzo (see next page)

Granolithic ~ a mix of cement, fine aggregate and granite or whinstone chippings in the ratio of 1:1:2 by volume. A dense, hard-wearing concrete characterised by the sparkle of granite. Specific applications include heavily pedestrianised floors particularly in public buildings, schools, entrance lobbies to apartment blocks and for floors in industrial production areas. Easy maintenance and durability are the main benefits, although it is notably cold to the touch and noisy under foot traffic.

Monolithic application to a standard concrete base is preferred. This should be within three hours of the substrate being placed. Otherwise a matured concrete base will need to be hacked to provide a key and then primed with a cement slurry to ensure adhesion. A PVA bonding agent may also be used as an alternative surface primer. The granolithic is effectively a screed of at least 20mm thickness as applied to a fresh concrete substrate, or at least 40mm thickness as applied to hardened concrete.

Base concrete thickness (mm)	Max. granolithic bay size (m <sup>2</sup> )
150	30
100	15

Note: Bay joints abutted to coincide with base concrete joints.

Surface treatment is by steel trowelling at least three times at two- to three-hour intervals to produce a hard, uniform and abrasion resistant finish.

An economical alternative that may be adequate in less heavily used situations can be achieved by sprinkling the surface of newly laid wet concrete with a cement and granite mix in the ratio of 1:2. Finishing is with a wood float and steel trowel.



## Concrete Surface Finishes (4)

Terrazzo ~ an attractive concrete composed of coloured cement and fine aggregate in the ratio of 1:2 by volume, with irregular shaped fragments of marble bedded in randomly and close together.

Marble aggregate grades	Size (mm)
00	1.5 to 2.5 (small panels)
0	2.5 to 3.0
1	3.0 to 6.0
2	6.0 to 10
3	10 to 12
4	12 to 20
5	20 to 25

Applied monolithically over a 15 to 25mm screed of cement and sand (1:3) with embedded non-ferrous metal or plastic dividing strips to produce maximum areas of 1m<sup>2</sup> over a standard concrete sub-base. Finishing is by light trowelling, coarse and then fine grinding with carborundum stone and water, followed by polishing. All this is a time consuming process extending over several days, thereby limiting the use of terrazzo to high budget projects.

Monolithic terrazzo floor construction

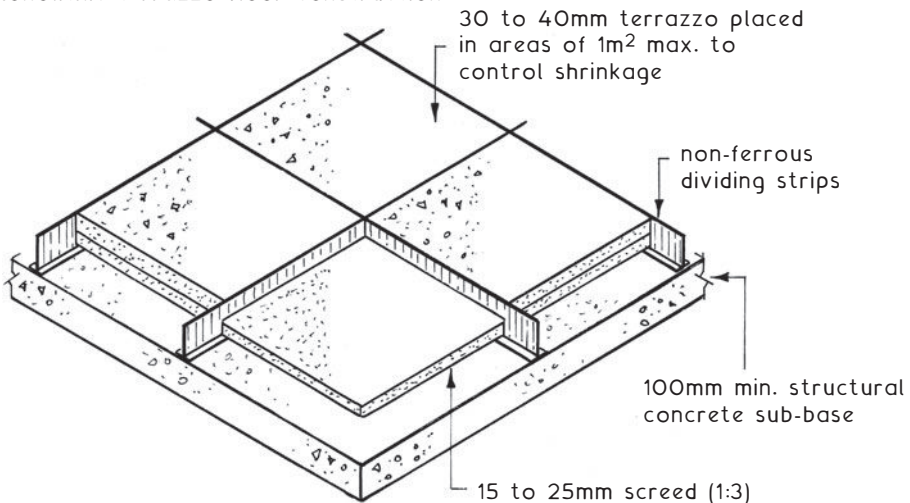

Synthetic polymer or resin-based binders are now quite common with thin-set terrazzo finishes of 6 to 10mm thickness. These are less susceptible to shrinkage cracking, but are limited to internal situations as they are not as robust as traditional cement-based terrazzo.

Discoloration ~ manifests as a patchy surface finish. It is caused where there are differences in hydration or moisture loss during the concrete set, due to concentrations of cement or where aggregates become segregated. Both of these will produce moisture content differences at the surface. Areas with a darker surface indicate the greater loss of moisture, possibly caused by insufficient mixing and/or poorly sealed formwork producing differences in surface absorption.

Crazing ~ surface shrinkage cracks caused by a cement-rich surface skin or by too much water in the mix. Out-of-date cement can have the same effect as well as impairing the strength of the concrete.

Lime bloom ~ a chalky surface deposit produced when the calcium present in cement reacts to contamination from moisture in the atmosphere or rainwater during the hydration process. Generally resolved by dry brushing or with a 20:1 water/hydrochloric acid wash.

Scabbing ~ small areas or surface patches of concrete falling away as the formwork is struck. Caused by poor preparation of formwork, i.e. insufficient use of mould oil or by formwork having a surface texture that is too rough.

Blow holes ~ otherwise known as surface popping. Possible causes are use of formwork finishes with nil or low absorbency or by insufficient vibration of concrete during placement.

Rust staining ~ if not caused by inadequate concrete cover to reinforcement, this characteristic is quite common where iron-rich aggregates or pyrites are used. Rust-brown stains are a feature and there may also be some cracking where the iron reacts with the cement.

Dusting ~ caused by unnaturally rapid hardening of concrete and possibly where out-of-date cement is used. The surface of set concrete is dusty and friable.

*This page intentionally left blank*

# 7 INTERNAL CONSTRUCTION AND FINISHES

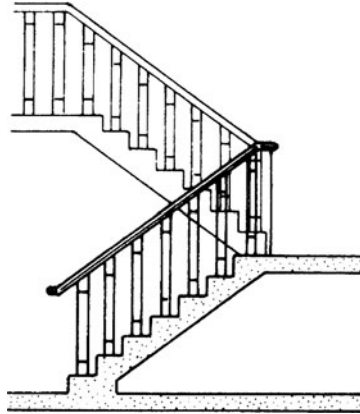

INTERNAL ELEMENTS  
INTERNAL WALLS  
CONSTRUCTION JOINTS  
PARTITIONS AND TIMBER STRUT DESIGN  
PLASTERS, PLASTERING AND PLASTERBOARD  
DRY LINING TECHNIQUES  
WALL TILING  
DOMESTIC FLOORS AND FINISHES  
LARGE CAST IN-SITU GROUND FLOORS  
CONCRETE FLOOR SCREEDS  
TIMBER SUSPENDED UPPER FLOORS  
TIMBER BEAM DESIGN  
REINFORCED CONCRETE SUSPENDED FLOORS  
PRECAST CONCRETE FLOORS  
RAISED ACCESS FLOORS  
SOUND INSULATION  
TIMBER, CONCRETE AND METAL STAIRS  
INTERNAL DOORS  
FIRE-RESISTING DOORS  
PLASTERBOARD CEILINGS  
SUSPENDED CEILINGS  
PAINTS AND PAINTING  
JOINERY PRODUCTION  
COMPOSITE BOARDING  
PLASTICS IN BUILDING

# Internal Elements

NB. roof coverings, roof insulation and guttering not shown.

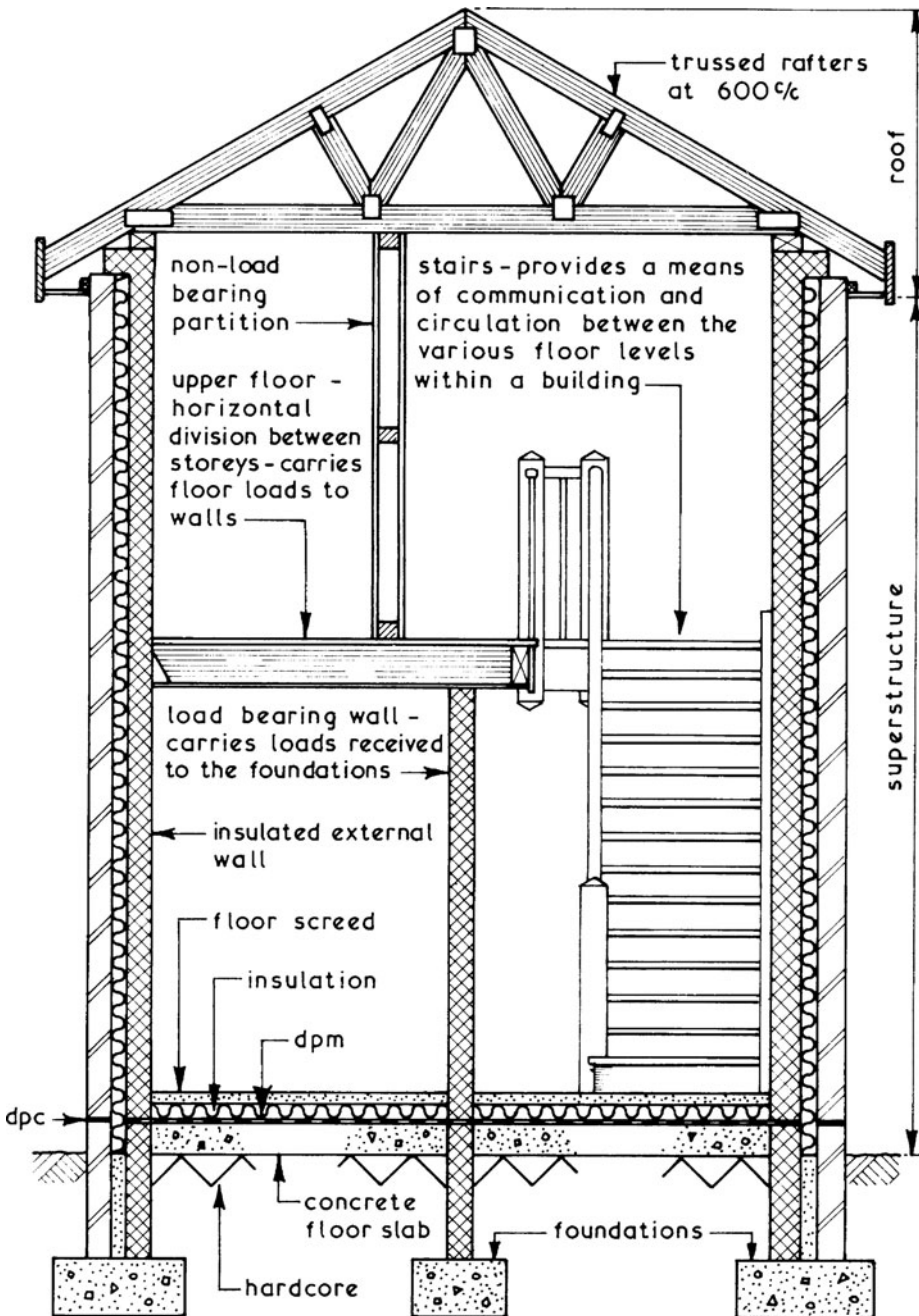

NB. All work below dpc level is classed as substructure.

Internal Walls ~ their primary function is to act as a vertical divider of floor space and in so doing form a storey-height enclosing element.

Other Possible Functions ~

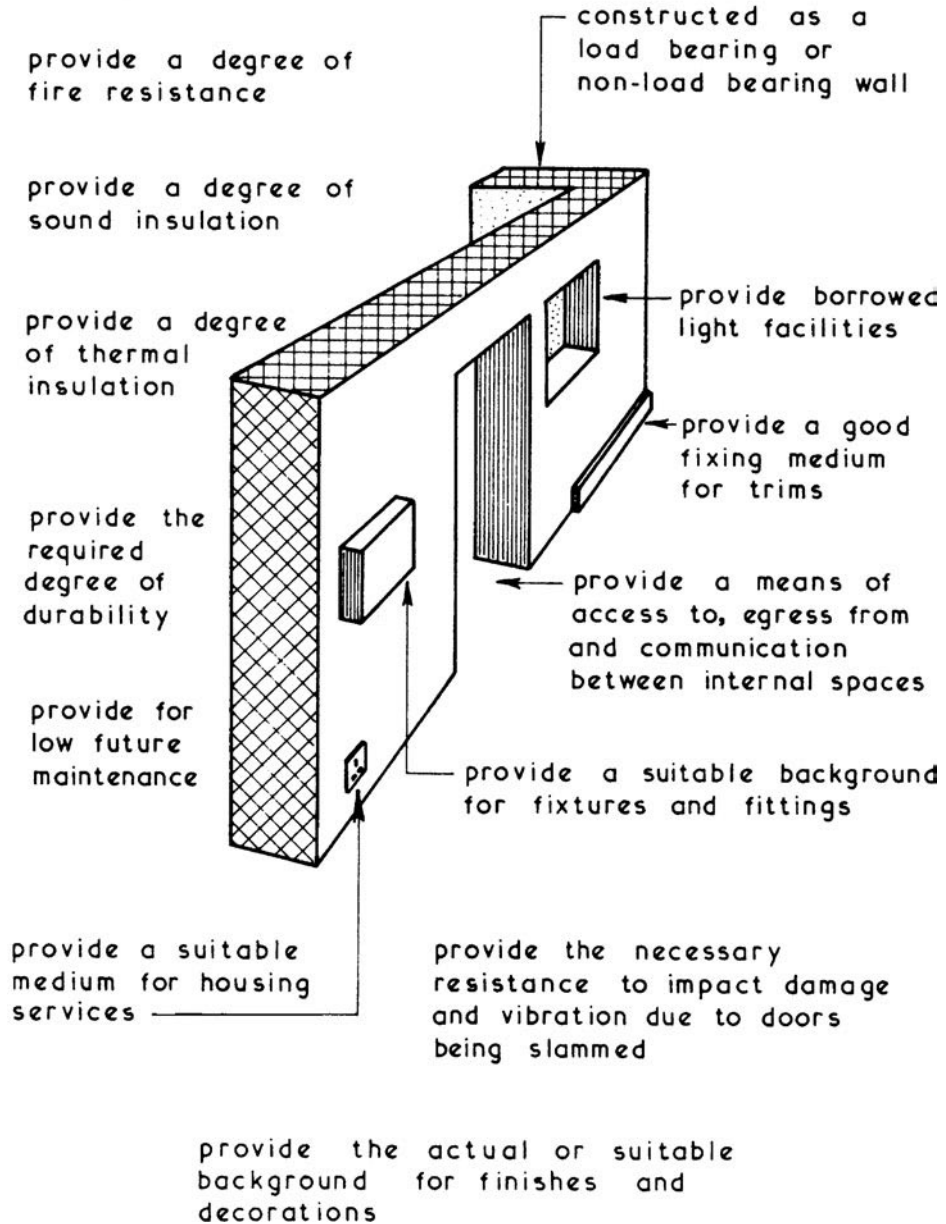

## Internal Walls – Types

Internal Walls ~ there are two basic design concepts for internal walls: those which accept and transmit structural loads to the foundations are called Load bearing Walls and those which support only their own self-weight and do not accept any structural loads are called Non-load bearing Walls or Partitions.

Typical Examples ~

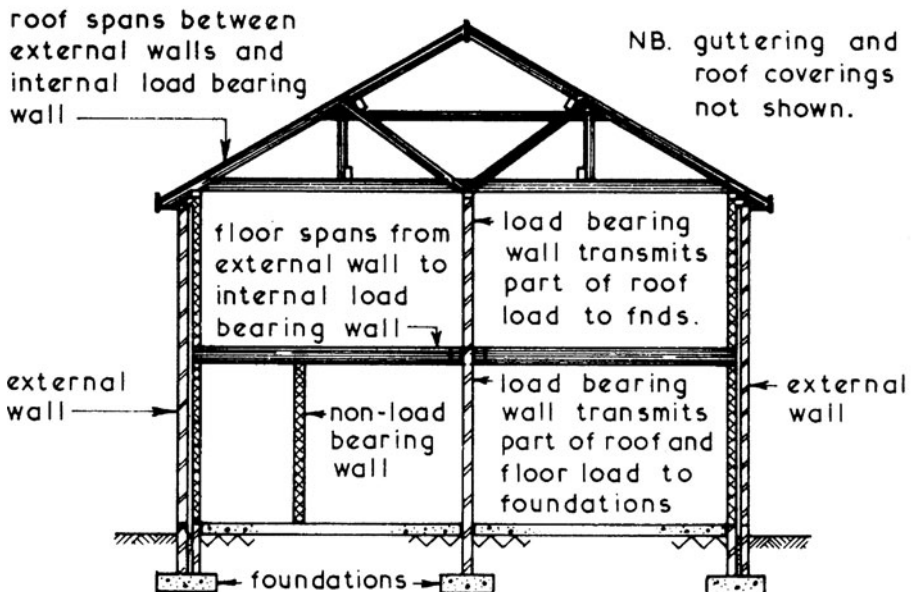
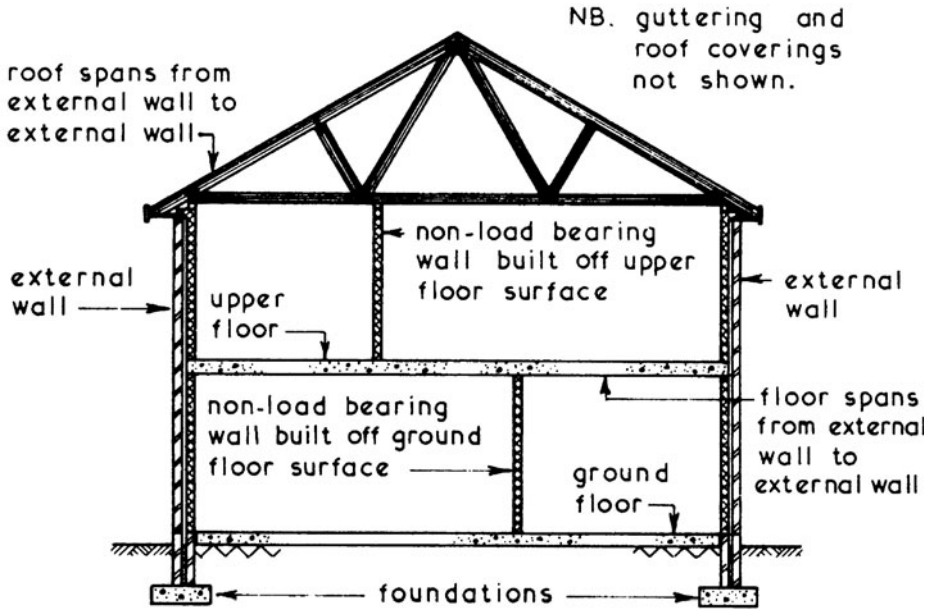

Internal Brick Walls ~ these can be load bearing or non-load bearing (see previous page) and for most two-storey buildings are built in half brick thickness in stretcher bond.

Typical Details ~

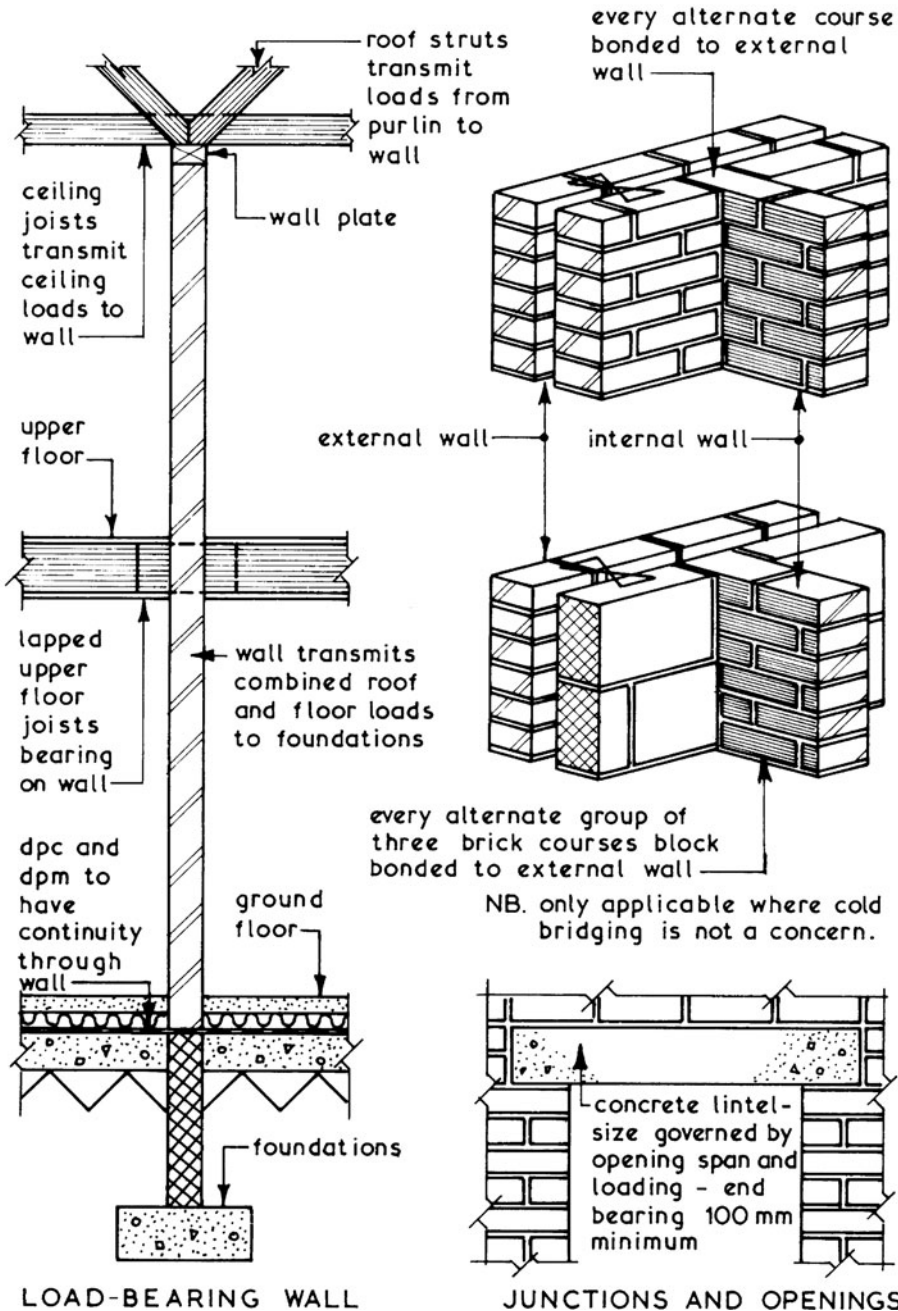



# Internal Block Walls

Internal Block Walls ~ these can be load bearing or non-load bearing (see page 730); the thickness and type of block to be used will depend upon the loadings it has to carry.

Typical Details ~

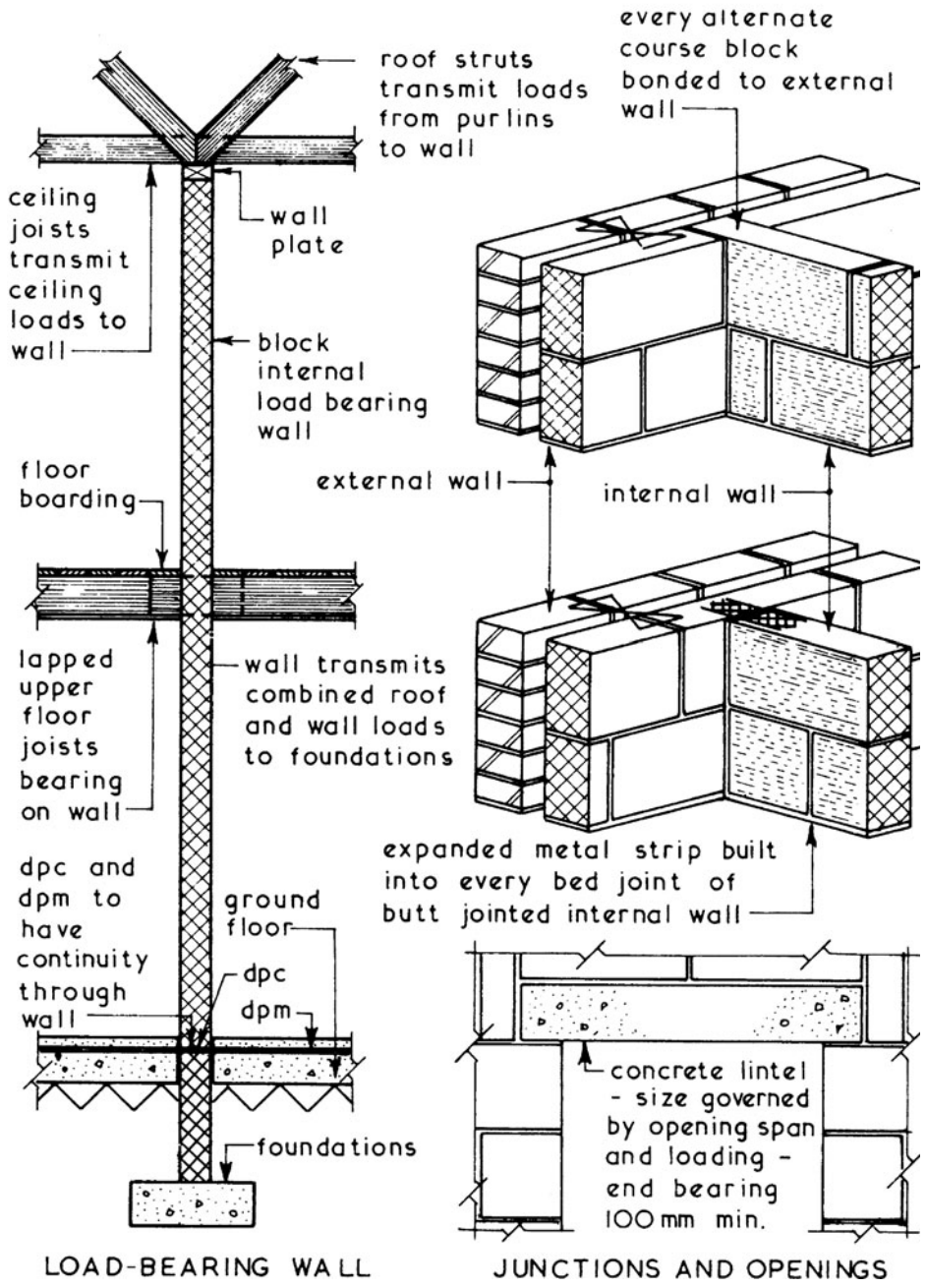

Internal Walls ~ an alternative to brick and block bonding shown on the preceding two pages is application of wall profiles. These are quick and simple to install, provide adequate lateral stability, sufficient movement flexibility and will overcome the problem of thermal bridging where a brick partition would otherwise bond into a block inner leaf. They are also useful for attaching extension walls at right angles to existing masonry.

Application ~

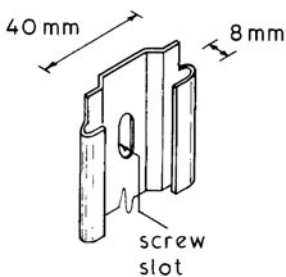
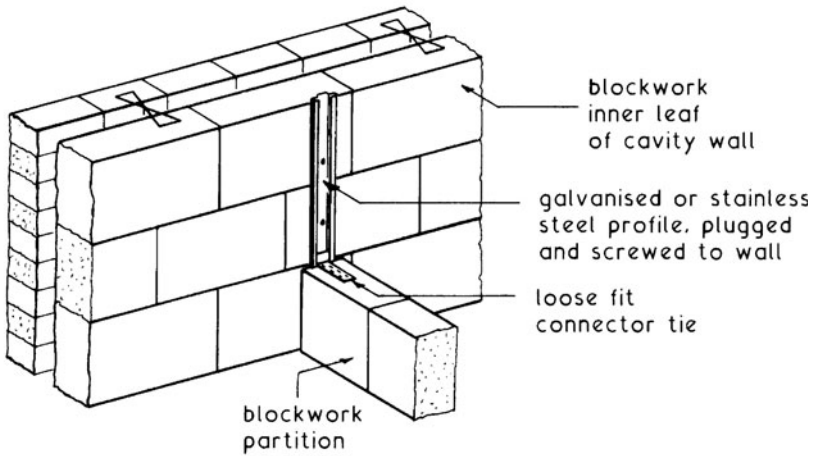

WALL PROFILE ~ 2.4 m long

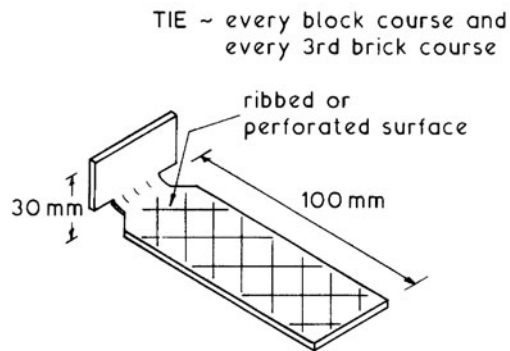

## Construction Joints

Movement or Construction Joints ~ provide an alternative to ties or mesh reinforcement in masonry bed joints. Even with reinforcement, lightweight concrete block walls are renowned for producing unsightly and possibly unstable shrinkage cracks. Galvanised or stainless steel formers and ties are built in at a maximum of 6m horizontal spacing and within 3m of corners to accommodate initial drying, shrinkage movement and structural settlement. One side of the former is fitted with profiled or perforated ties to bond into bed joints and the other has plastic sleeved ties. The sleeved tie maintains continuity, but restricts bonding to allow for controlled movement.

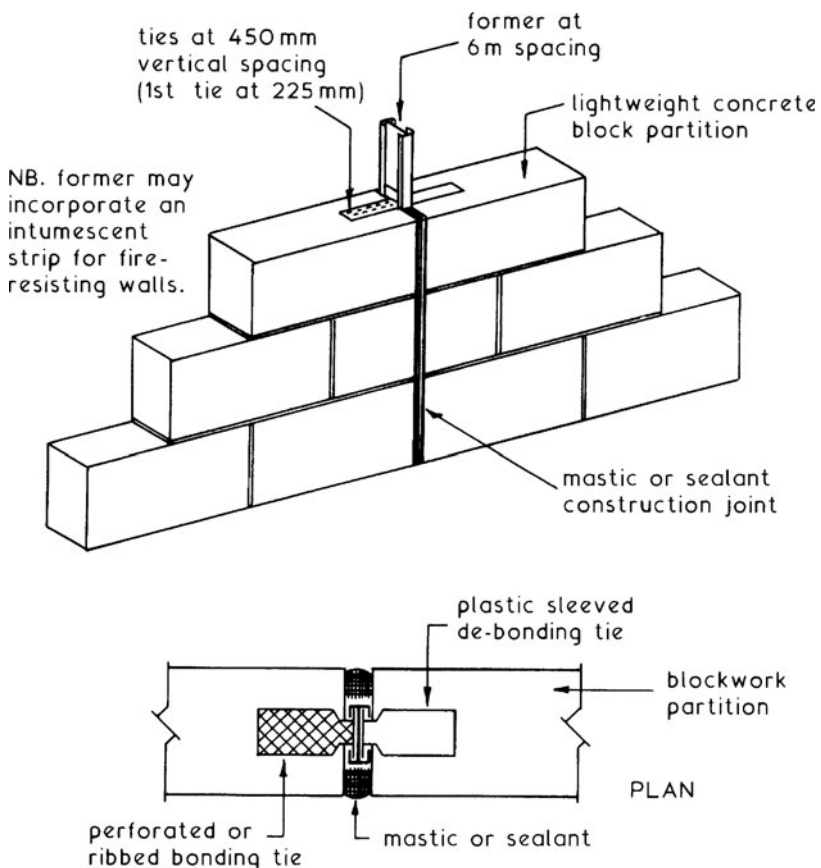

NB. Movement joints in clay brickwork should be provided at 12m maximum spacing and 7.5 to 9m for calcium silicate.

Refs.: BS EN 1996: Design of masonry structures.

PD 6697: Recommendations for the design of masonry structures.

Location ~ specifically in positions of high stress.  
Reinforcement ~ expanded metal or wire mesh (see page 388).  
Mortar Cover ~ 13 mm minimum thickness, 25 mm to external faces.

Openings ~

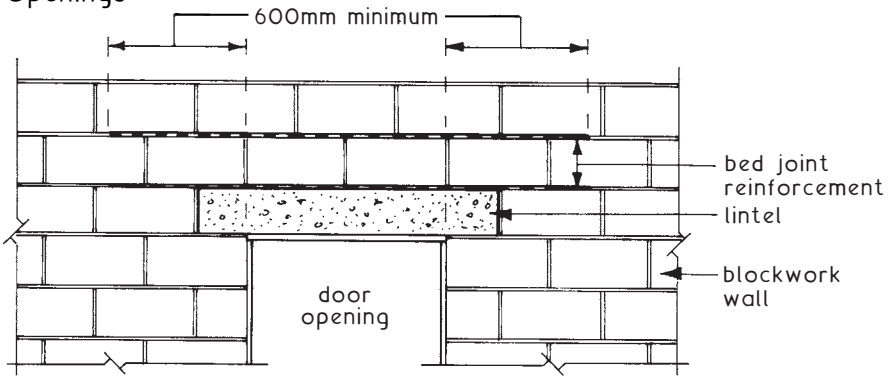

Concentrated Load ~

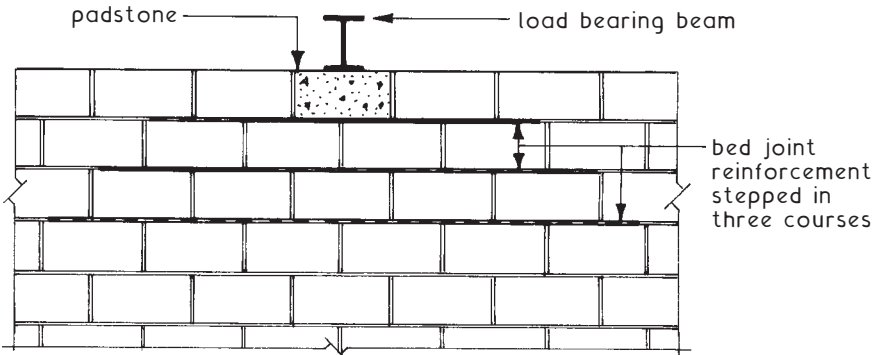

Suspended Floor~

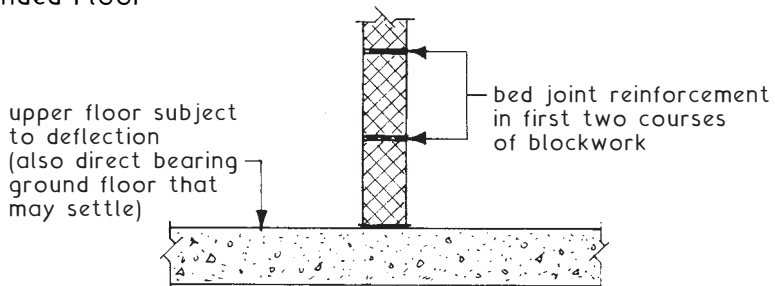

Differential Movement ~ may occur where materials such as steel, brick, timber or dense concrete abut with or bear on lightweight concrete blocks. A smooth separating interface of two layers of non-compressible dpc or similar is suitable in this situation.

# Internal Masonry Walls - Fire Protection

Typical Examples ~

Solid brickwork

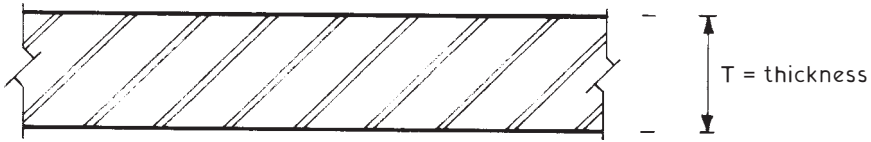

	Fire resistance (minutes)		Material and application
	120	240	
T (mm)	102.5	215	Clay bricks. Load bearing or non-load bearing wall.
T (mm)	102.5	215	Concrete or sand/lime bricks. Load bearing or non-load bearing wall.

NB. For practical reasons a standard one-brick dimension is given for 240 minutes' fire resistance. Theoretically a clay brick wall can be 170 mm and a concrete or sand/lime brick wall 200 mm, finishes excluded.

Solid concrete blocks of lightweight aggregate

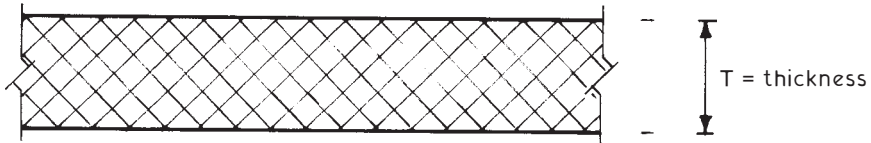

	Fire resistance (minutes)			Material and application
	60	120	240	
T (mm)	100	130	200	Load bearing, 2.8-3.5 N/mm <sup>2</sup> compressive strength.
T (mm)	90	100	190	Load bearing, 4.0-10 N/mm <sup>2</sup> compressive strength.
T (mm)	75	100	140	Non-load-bearing, 2.8-3.5 N/mm <sup>2</sup> compressive strength.
T (mm)	75	75	100	Non-load bearing, 4.0-10 N/mm <sup>2</sup> compressive strength.

NB. Finishes excluded.

Party Wall ~ a wall separating different owners' buildings, i.e. a wall that stands astride the boundary line between property of different ownerships. It may also be solely on one owner's land but used to separate two buildings.

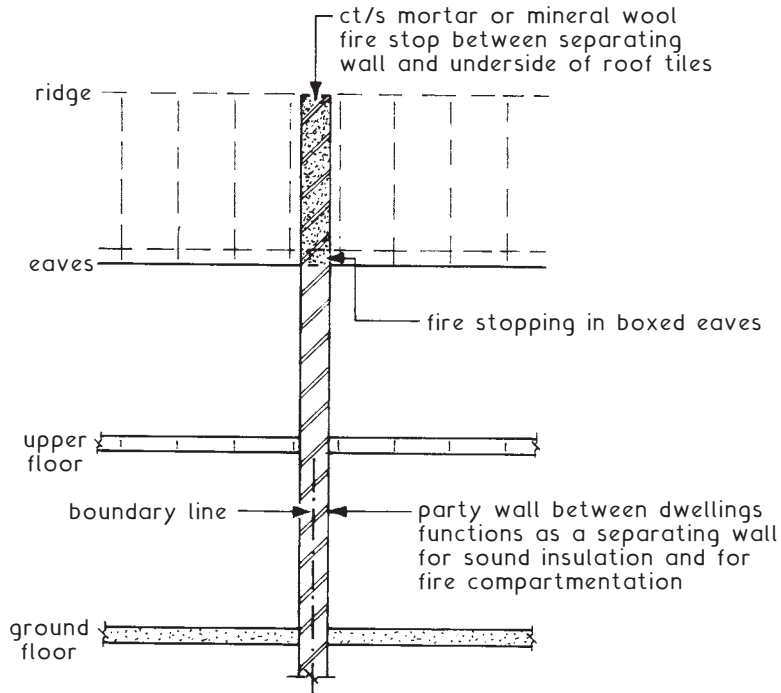

Where an internal separating wall forms a junction with an external cavity wall, the cavity must be fire stopped by using a barrier of fire-resisting material. Depending on the application, the material specification is of at least 30 minutes' fire resistance. Between terraced and semi-detached dwellings the location is usually limited by the separating elements. For other buildings additional fire stopping will be required in constructional cavities such as suspended ceilings, rainscreen cladding and raised floors. The spacing of these cavity barriers is generally not more than 20 m in any direction, subject to some variation as indicated in Volume 2 of Approved Document B.

Refs.:

Party Wall Act 1996.

Building Regulations, A.D. B, Volumes 1 and 2: Fire safety.

Building Regulations, A.D. E: Resistance to the passage of sound.

# Internal Party/Separating Walls

Requirements for fire- and sound-resisting construction ~

Typical masonry construction ~

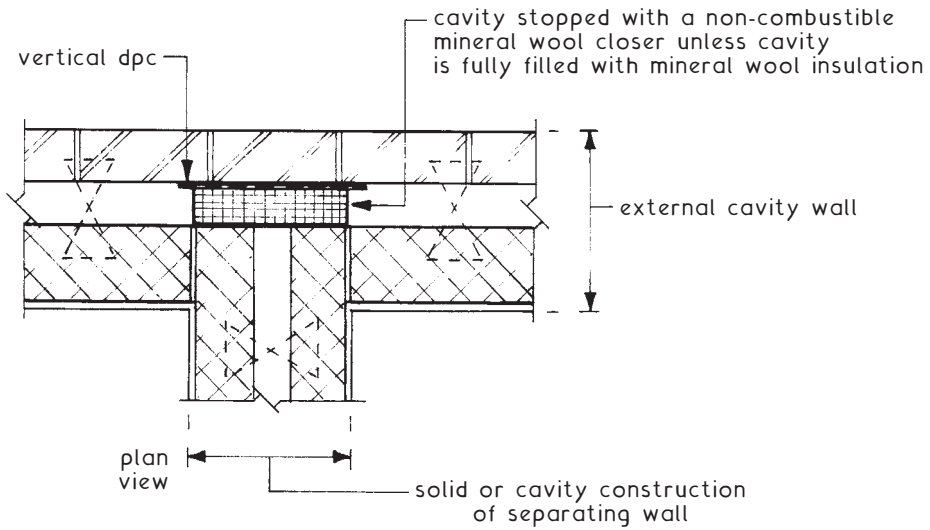

Typical timber framed construction~

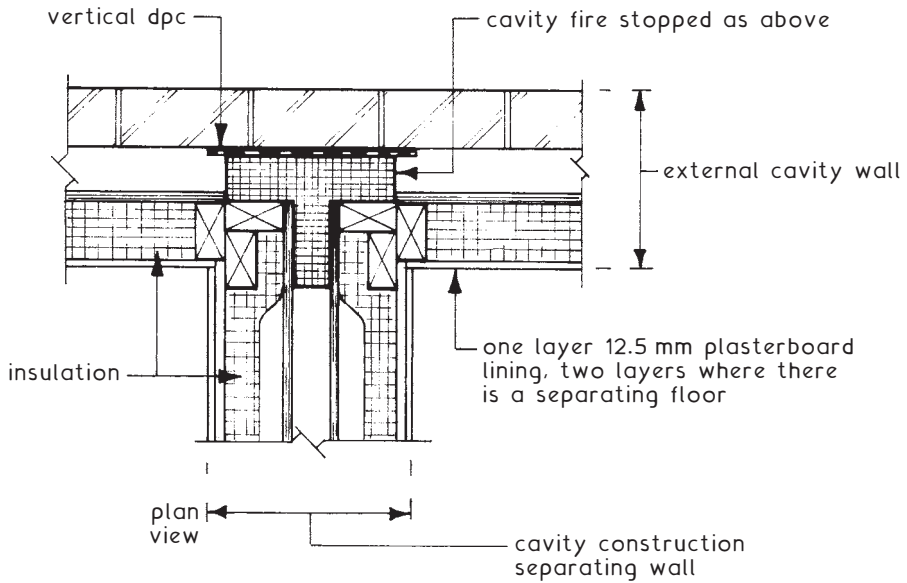

Internal Partitions ~ these are vertical dividers which are used to separate the internal space of a building into rooms and circulation areas such as corridors. Partitions which give support to a floor or roof are classified as load bearing whereas those which give no such support are called non-load bearing.

Load Bearing Partitions ~ these walls can be constructed of bricks, blocks or in-situ concrete by traditional methods and have the design advantages of being capable of having good fire resistance and/or high sound insulation. Their main disadvantage is permanence giving rise to an inflexible internal layout.

Non-load Bearing Partitions ~ the wide variety of methods available makes it difficult to classify the form of partition but most can be placed into one of three groups:

1. Masonry partitions.
2. Stud partitions - see pages 740 to 743.
3. Demountable partitions - see pages 744 and 745.

Masonry Partitions ~ these are usually built with blocks of clay or lightweight concrete which are readily available and easy to construct thus making them popular. These masonry partitions should be adequately tied to the structure or load bearing walls to provide continuity as a sound barrier, provide edge restraint and to reduce the shrinkage cracking which inevitably occurs at abutments. Wherever possible openings for doors should be in the form of storey-height frames to provide extra stiffness at these positions.

#### Typical Details ~

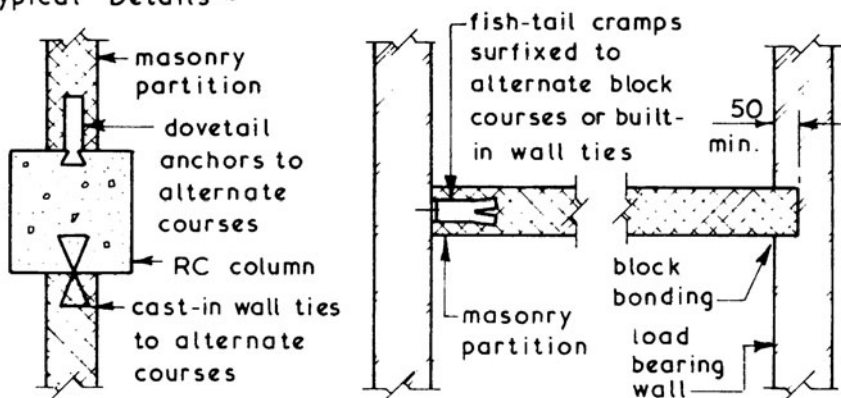



# Timber Stud Partitions

Timber Stud Partitions ~ these are non-load bearing internal dividing walls which are easy to construct, lightweight, adaptable and can be clad and infilled with various materials to give different finishes and properties. The timber studs should be of prepared or planed material to ensure that the wall is of constant thickness with parallel faces. Stud spacings will be governed by the size and spanning ability of the facing or cladding material.

Typical Details ~

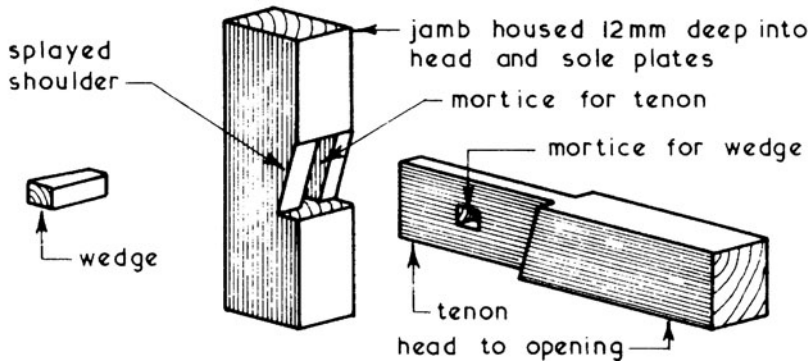
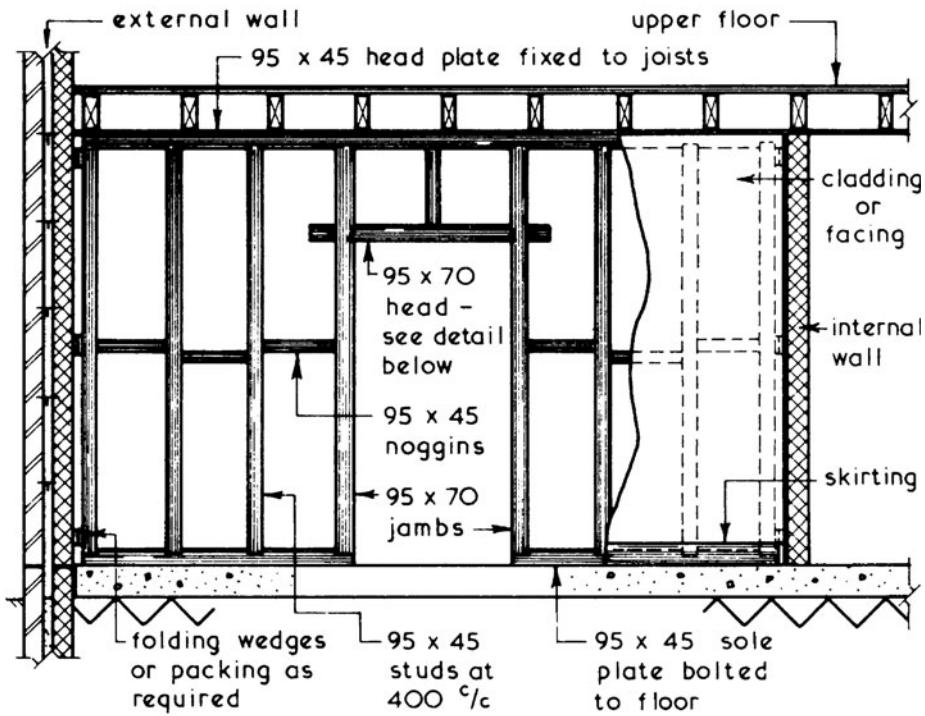

Although generally non-load bearing, timber stud partitions may carry some of the load from the floor and roof structure. In these situations the vertical studs are considered struts.

Example ~ using the stud frame dimensions shown on the previous page, with each stud (strut) supporting a 5kN load.

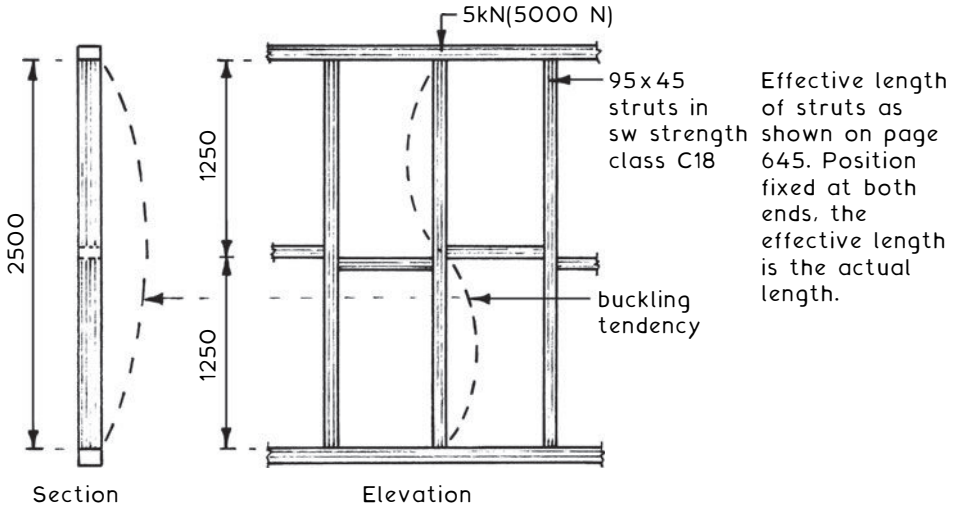

Slenderness ratio (SR) of section = effective length ÷ breadth

On the partition face =  $1250 \div 45 = 27.8$

At right angles to the face =  $2500 \div 95 = 26.3$

Timber of strength classification C18 (see pages 141 and 142) has the following properties:

Modulus of elasticity =  $6000 \text{ N/mm}^2$

Grade stress in compression parallel to the grain =  $7.1 \text{ N/mm}^2$

Grade stress ratio =  $6000 \div 7.1 = 845$

See table on page 194. By coordinating the SR of 27.8 (greater value) with a grade stress ratio of 845, a figure of 0.4 is obtained by interpolation.

Allowable applied stress is  $7.1 \text{ N/mm}^2 \times 0.4 = 2.84 \text{ N/mm}^2$

Applied stress = axial load ÷ strut section area

=  $5000 \text{ N} \div (95 \text{ mm} \times 45 \text{ mm}) = 1.17 \text{ N/mm}^2$

$1.17 \text{ N/mm}^2$  is well within the allowable stress of  $2.84 \text{ N/mm}^2$ ; therefore  $95 \text{ mm} \times 45 \text{ mm}$  struts are adequate.

NB. See pages 192 to 194 for an application to dead shoring. Struts in trusses and lattice frames can also be designed using the same principles.

# Metal Stud Partitions

Stud Partitions ~ these non-load bearing partitions consist of a framework of vertical studs to which the facing material can be attached. The void between the studs created by the two faces can be infilled to meet specific design needs. The traditional material for stud partitions is timber (see Timber Stud Partitions on page 740) but a similar arrangement can be constructed using metal studs faced on both sides with plasterboard.

## Typical Metal Stud Partition Details ~

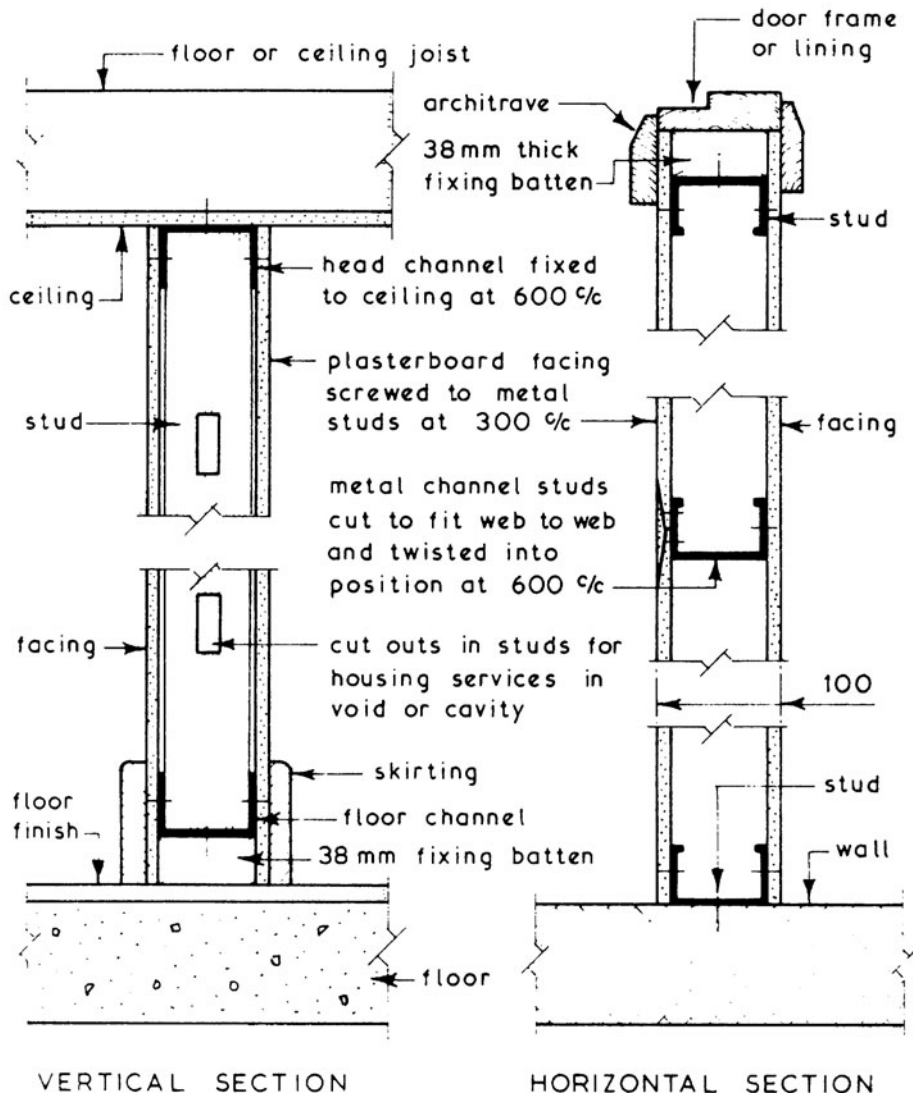

## Stud Partitions - Fire Protection

Plasterboard lining to stud-framed partition walls satisfies the Building Regulations, Approved Document B - Fire safety, as a material of 'limited combustibility' with a Class O rating for surface spread of flame (Class O is better than Classes 1 to 4 as determined by BS 476-7). The plasterboard dry walling should completely protect any combustible timber components such as sole plates. The following shows typical fire resistances as applied to a metal stud frame ~

30-minute fire resistance

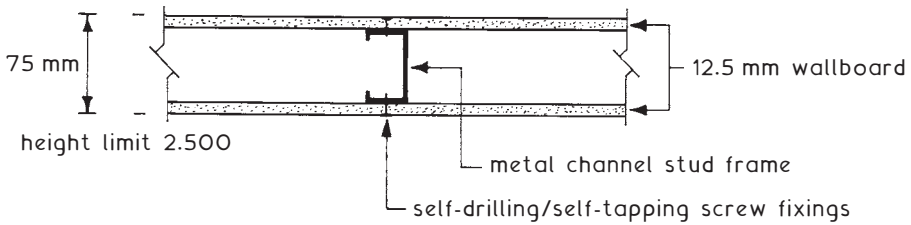

60(90)-minute fire resistance

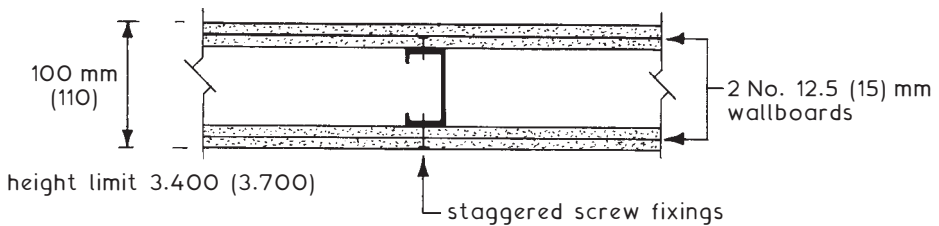

120-minute fire resistance

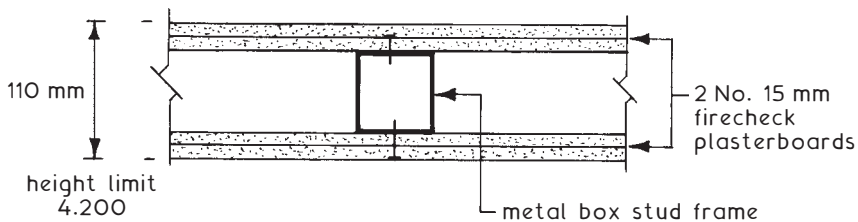

NB. For plasterboard types see page 753.

# Demountable Partitions

Partitions ~ these can be defined as vertical internal space dividers and are usually non-load bearing. They can be permanent, constructed of materials such as bricks or blocks or they can be demountable constructed using lightweight materials and capable of being taken down and moved to a new location incurring little or no damage to the structure or finishes. There is a wide range of demountable partitions available constructed from a variety of materials giving a range that will be suitable for most situations. Many of these partitions have a permanent finish which requires no decoration and only periodic cleaning in the context of planned maintenance.

Typical Example ~

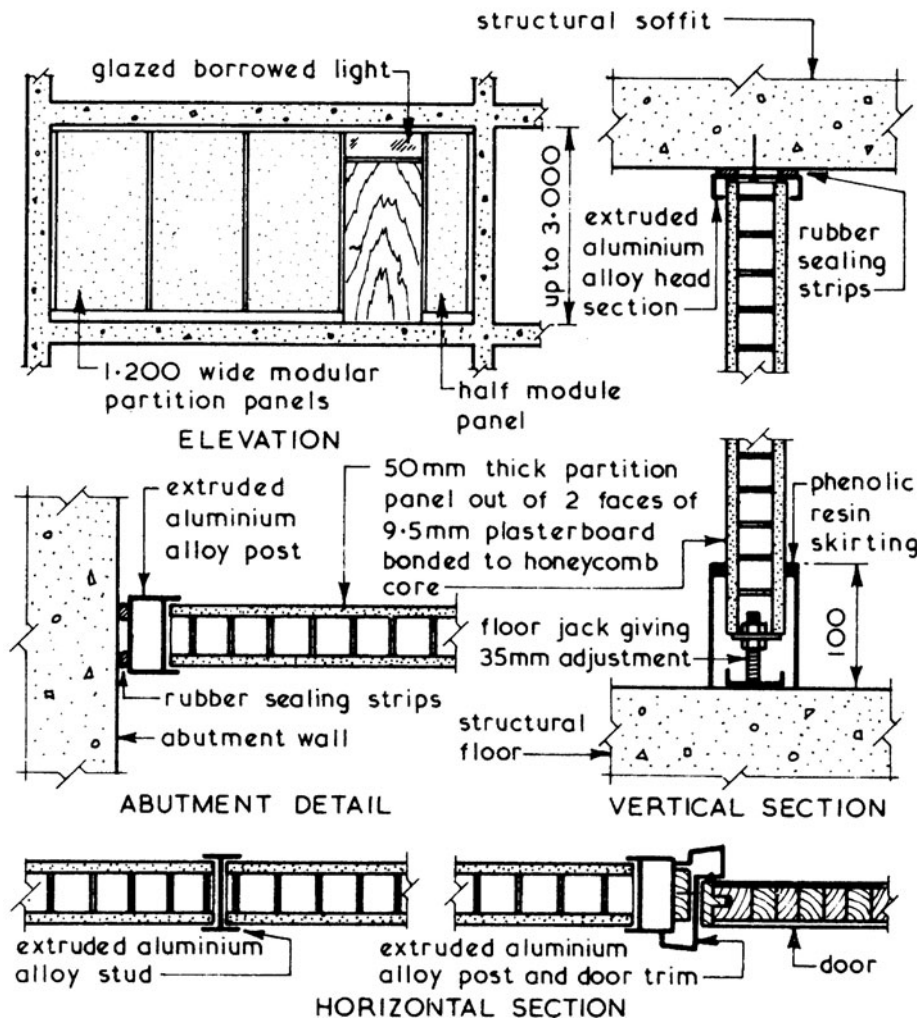

Demountable Partitions ~ it can be argued that all internal non-load bearing partitions are demountable and therefore the major problem is the amount of demountability required in the context of ease of moving and the possible frequency anticipated. The range of partitions available is very wide including stud partitions, framed panel partitions (see Demountable Partitions on page 744), panel to panel partitions and sliding/folding partitions which are similar in concept to industrial doors (see Industrial Doors on pages 467 to 469). The latter type is often used where movement of the partition is required frequently. The choice is therefore based on the above stated factors taking into account finish and glazing requirements together with any personal preference for a particular system but in all cases the same basic problems will have to be considered ~

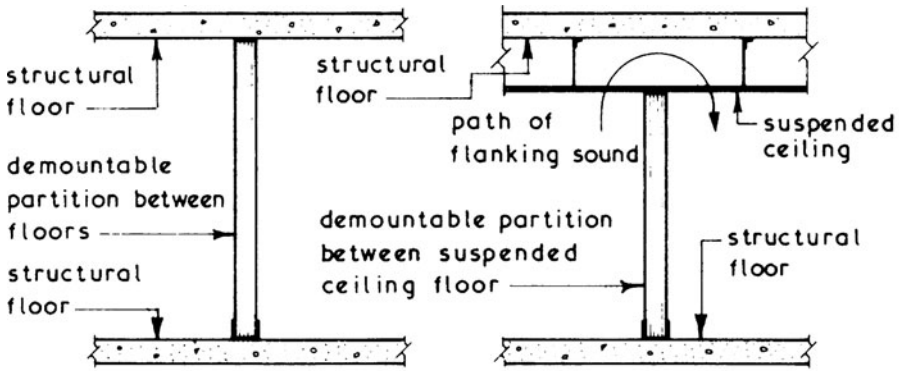

METHOD 1 - easily demounted and re-erected, good sound insulation can be achieved.

METHOD 2 - easily demounted and re-erected if ceiling can take pressure, flanking sound may be a problem.

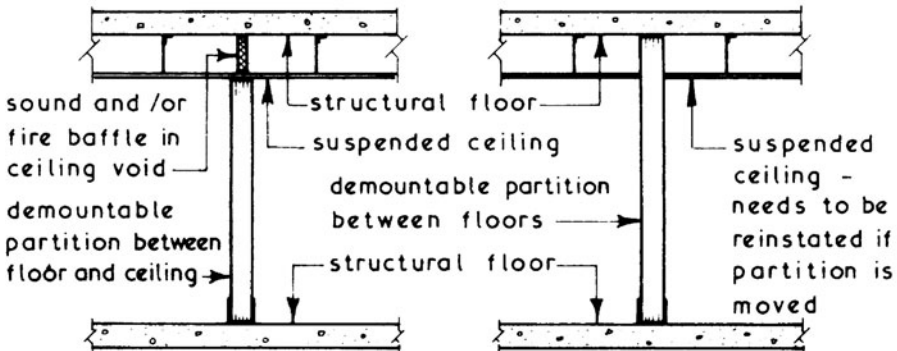

METHOD 3 - alternative to 2.

METHOD 4 - alternative to 3.

## Plasters

Plaster ~ this is a wet mixed material applied to internal walls as a finish to fill in any irregularities in the wall surface and to provide a smooth continuous surface suitable for direct decoration. The plaster finish also needs to have a good resistance to impact damage. The material used to fulfil these requirements is gypsum plaster. Gypsum is a crystalline combination of calcium sulphate and water. The raw material is crushed, screened and heated to dehydrate the gypsum and this process together with various additives defines its type as set out in BS EN 13279-1: Gypsum binders and gypsum plasters. Definitions and requirement.

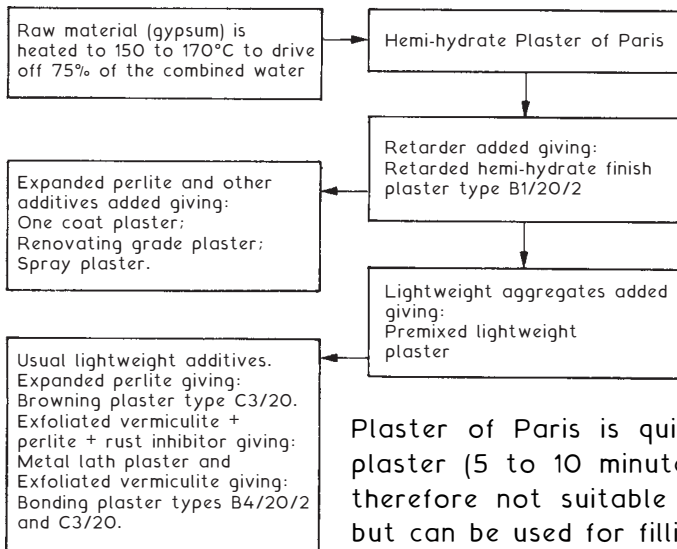

Plaster of Paris is quick-setting plaster (5 to 10 minutes) and is therefore not suitable for walls but can be used for filling cracks and cast or run mouldings.

Browning and bonding plasters are used as undercoats to premixed lightweight plasters.

All plaster should be stored in dry conditions since any absorption of moisture before mixing may shorten the normal setting time of about one and a half hours which can reduce the strength of the set plaster. Gypsum plasters are not suitable for use in temperatures exceeding 43°C and should not be applied to frozen backgrounds.

A good key to the background and between successive coats is essential for successful plastering. Generally brick and block walls provide the key whereas concrete unless cast against rough formwork will need to be treated to provide the key.

Internal Wall Finishes ~ these can be classified as wet or dry. The traditional wet finish is plaster which is mixed and applied to the wall in layers to achieve a smooth and durable finish suitable for decorative treatments such as paint and wallpaper.

Most plasters are supplied in 25kg paper sacks and require only the addition of clean water or sand and clean water according to the type of plaster being used.

Typical Method of Application ~

## 1. PREPARATION

surface well brushed with hard broom to remove loose material and dust

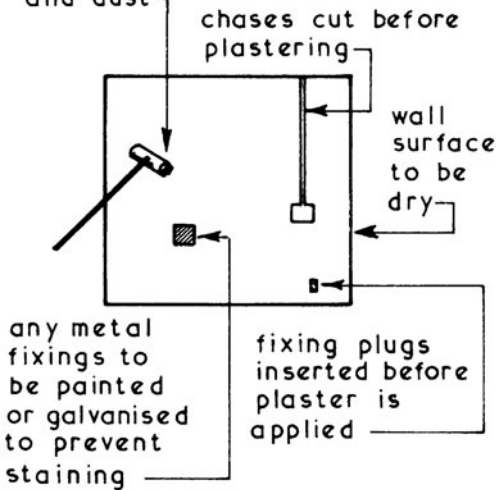

## 2. UNDERCOATING

thin coats of undercoat plaster applied and built up to required thickness

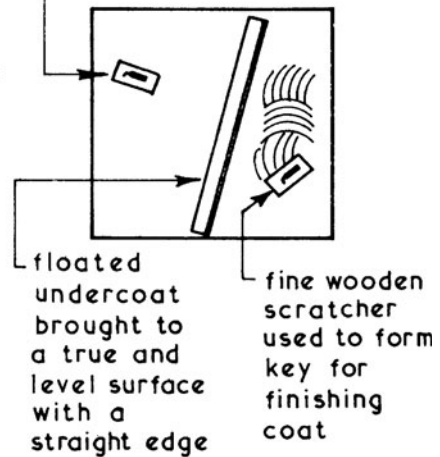

## 3. FINISHING

finishing coat of plaster applied with steel trowel to give a smooth finish

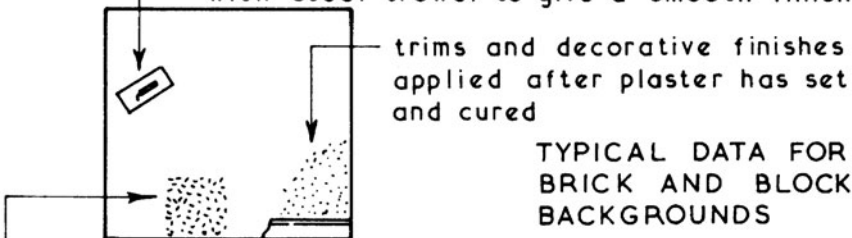

textured surfaces can be obtained by using a sponge, hair brush, felt float or steel combs

## TYPICAL DATA FOR BRICK AND BLOCK BACKGROUNDS

Undercoat - 8 to 10mm thick  
 Finishing coat - 2mm thick  
 Setting times:  
 Undercoat - 2 hours  
 Finishing coat - 1 hour



## Plaster Application

Background ~ ideally level and of consistent material. If there are irregularities, three applications may be required; render (ct. and sand) 10–12mm, undercoat plaster 6–8mm and finish plaster 2mm.

Difficult backgrounds such as steel or glazed surfaces require a PVA bonding agent or a cement slurry brushed on to improve plaster adhesion. A wire mesh or expanded metal surface attachment may also be required with metal lathing plaster as the undercoat. This may be mixed with sand in the ratio of 1:1.5.

Soft backgrounds of cork, fibreboard or expanded plastics should have wire mesh or expanded metal stapled to the surface. An undercoat of lightweight bonding plaster with compatible finish is suitable.

Dense regular surfaces of low-medium suction such as plasterboard require only one finishing coat of specially formulated finishing plaster.

Corners ~ reinforced with glass-fibre scrim tape or fine wire mesh to prevent shrinkage cracking at the junction of plasterboard ceiling and wall. Alternatively a preformed gypsum plaster moulding can be nailed or attached with plaster adhesive (see page 844). Expanded metal angle beads are specifically produced for external corner reinforcement. These are attached with plaster dabs or galvanised nails before finishing just below the nosing.

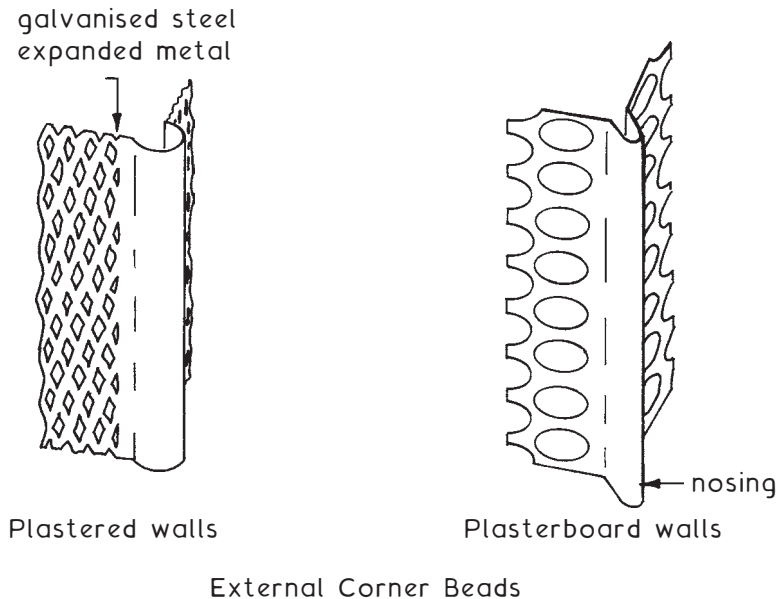

Stucco is often used as a generalisation for plastered and rendered finishes to walls. This is very limited, as in the context of decoration and architecture it is a term that has acquired many interpretations and definitions that describe different styles of plastering and rendering to both interior and exterior walls. Some of these are used in the historical context and include elaborate ornamentation, particularly as applied to ancient buildings and classic styles of architecture. Stucco is also used as a material description of the mix composition, particularly with regard to its traditional lime base.

Architectural ~ often represented by carved, sculpted or moulded ornamental features as elaborate finish treatments to palaces, churches, mosques and other prominent buildings of religious and historical importance, not least those of the ancient Greek, Roman and Persian classical periods. Of particular architectural importance are the creative interpretations applied to the interior design and architectural features of Baroque (17th-century Italian) and Rococo (18th-century French) buildings.

Material (Traditional) ~ a mix of hydrated lime, fine sand and water used as a smooth, dense, hard covering to interior and exterior masonry walls. Animal or plant fibres may be added for strength with pigments and dyes for colour enhancement. Applied in two thin coats to masonry or three coats (scratch, brown and finish) to timber laths over timber framing.

Material (Contemporary) ~ typically composed of 3 parts hydrated lime to 10 parts fine sand with a nominal amount of cement to improve durability and sufficient water to make the mix workable. Glass fibres and synthetic acrylics may be added for strength. This mix can be used for repairs and renovation work to older buildings as it is less likely to crack or craze than cement and sand renders.

A high quality variation for interiors comprises fine gypsum plaster or hydrated lime mixed with marble dust and water to produce special feature finishes. There are many trade and commercial terms for this surface treatment, including polished plaster, marmorino and Venetian plaster.

## Dry Lining Techniques

Plasterboard ~ a board material comprising two outer layers of lining paper with gypsum plaster between - two edge profiles are generally available:

1. Tapered Edge - a flush seamless surface is obtained by filling the joint with a special filling plaster, applying a joint tape over the filling and finishing with a thin layer of joint filling plaster, the edge of which is feathered out using a slightly damp jointing sponge or steel trowel.
2. Square Edge - edges are close butted and finished with a cover fillet or the joint is covered with a glass-fibre scrim tape before being plastered.

Some jointing details are shown on page 755.

Typical Details ~

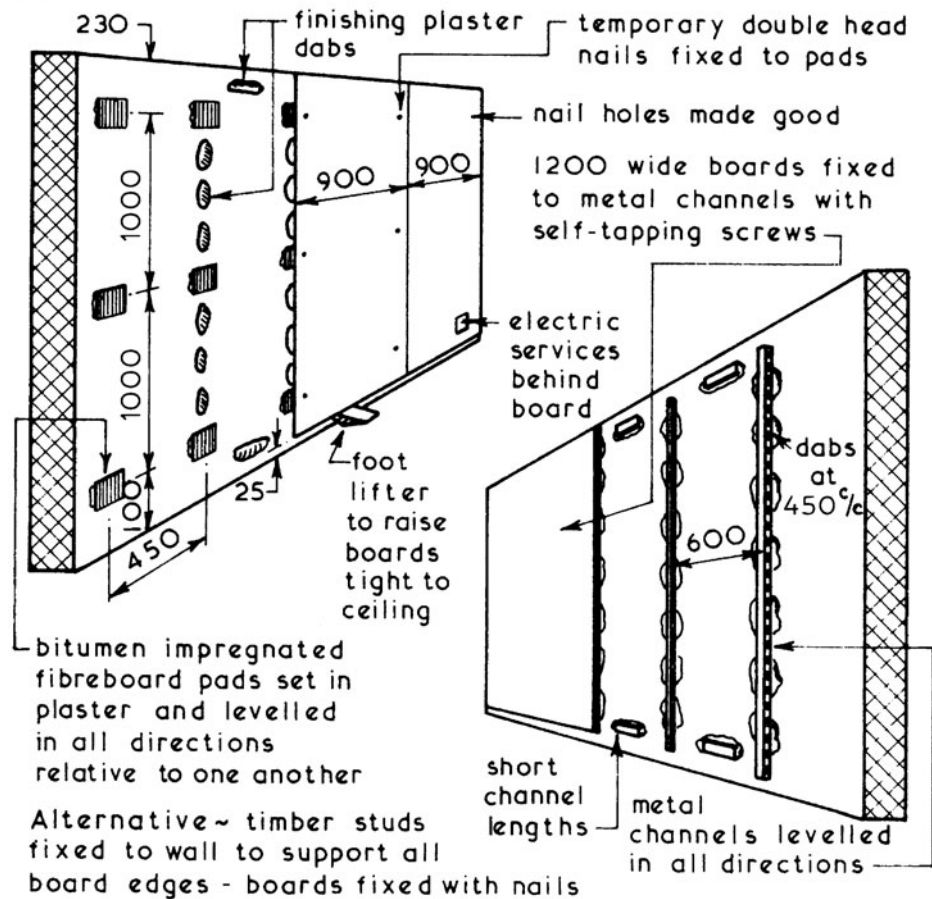

Dry Linings ~ an alternative to wet finishing internal wall surfaces with render and plaster. Dry lining materials can be plasterboard, insulating fibre board, hardboard, timber boards and plywood, all of which can be supplied with a permanent finish or they can be supplied to accept an applied finish such as paint or wallpaper. For plasterboard a dry wall sealer should be applied before wallpapering to permit easier removal at a later date. The main purpose of lining an internal wall surface is to provide an acceptable but not necessarily an elegant or expensive wall finish. It is also very difficult and expensive to build a brick or block wall which has a fair face to both sides since this would involve the hand selection of bricks and blocks to ensure a constant thickness together with a high degree of skill to construct a satisfactory wall. The main advantage of dry lining walls is that the drying out period required with wet finishes is eliminated. By careful selection and fixing of some dry lining materials it is possible to improve the thermal insulation properties of a wall. Dry linings can be fixed direct to the backing by means of a recommended adhesive or they can be fixed to a suitable arrangement of wall battens.

### Typical Example ~

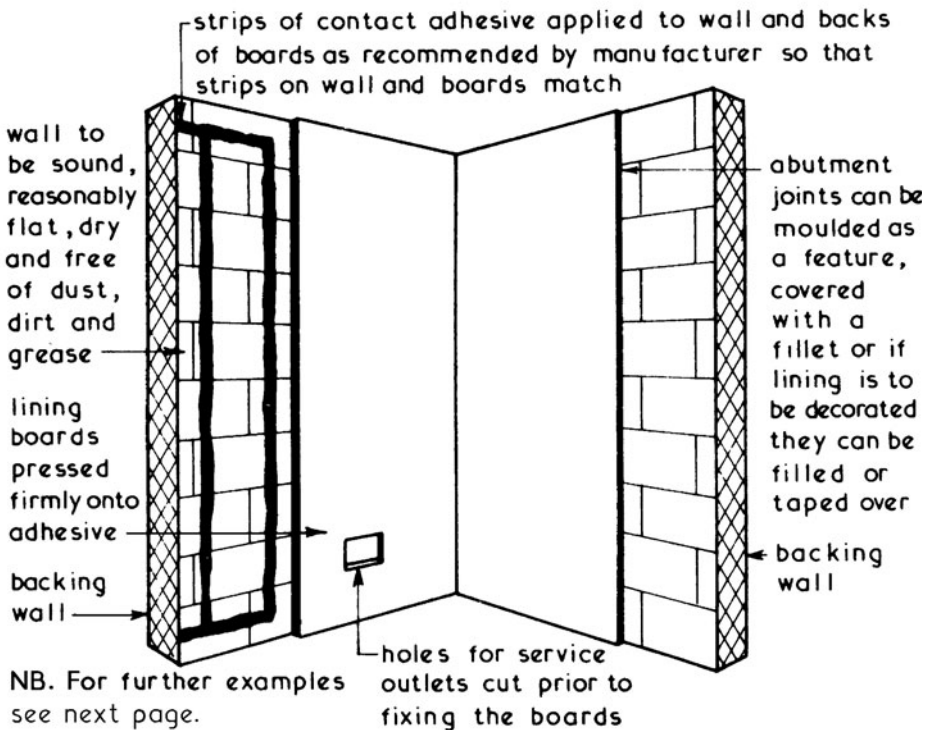

# Dry Lining Techniques

Typical Examples using Plywood or Similar Boarding ~

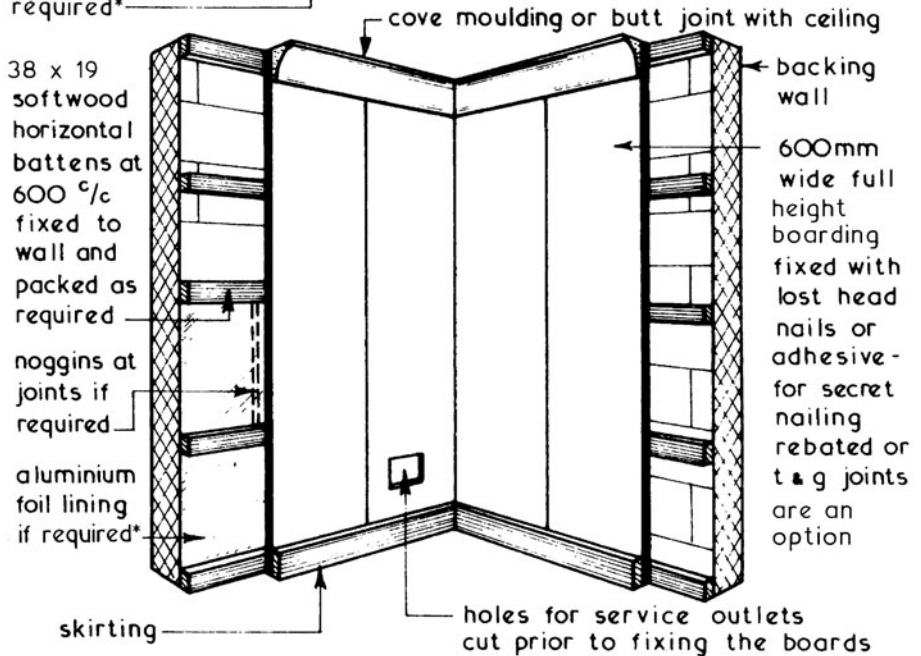
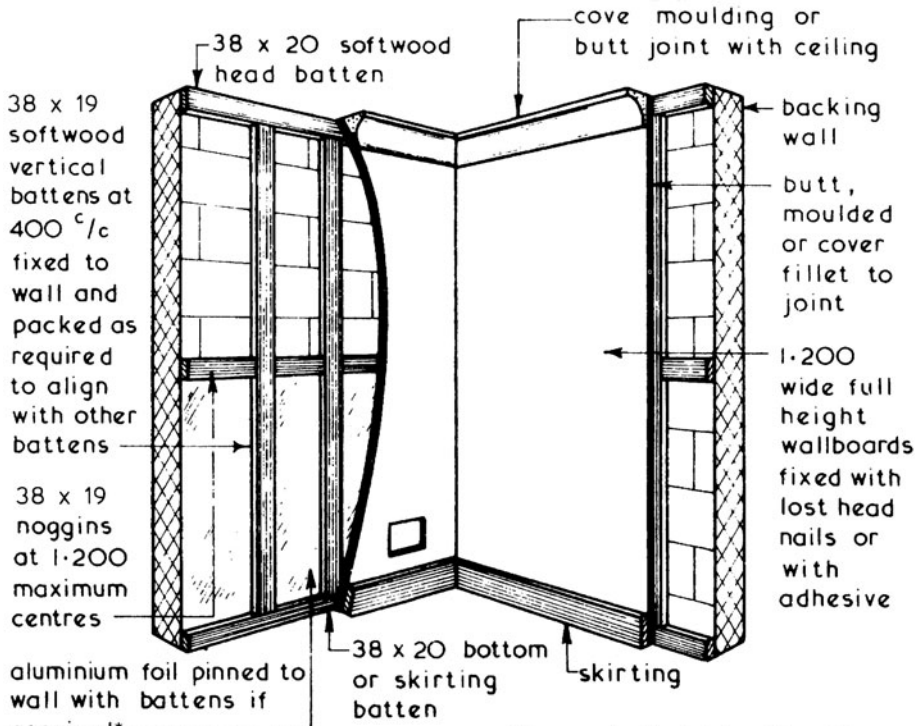

\*alternatively use polythene sheet as a vapour check.

Plasterboard Types ~ to BS EN 520: Gypsum plasterboards. Definitions, requirements and test methods.

#### BS PLASTERBOARDS:

1. Wallboard – ivory faced for taping, jointing and direct decoration; grey faced for finishing plaster or wall adhesion with plaster dabs. General applications, i.e. internal walls, ceilings and partitions. Thicknesses: 9.5, 12.5 and 15 mm. Widths: 900 and 1200 mm. Lengths: vary between 1800 and 3000 mm. Edge profile square or tapered.
2. Baseboard – lining ceilings requiring direct plastering.  
Thickness: 9.5 mm. Width: 900 mm. Length: 1220 mm.  
Thickness: 12.5 mm. Width: 600 mm. Length: 1220 mm.  
Edge profile square.
3. Moisture Resistant – wallboard for bathrooms and kitchens. Pale green colour to face and back. Ideal base for ceramic tiling or plastering.  
Thicknesses: 12.5 mm and 15 mm. Width: 1200 mm.  
Lengths: 2400, 2700 and 3000 mm.  
Square and taper edges available.
4. Firecheck – wallboard of glass fibre reinforced vermiculite and gypsum for fire cladding. Pink face and grey back.  
Thicknesses: 12.5 and 15 mm. Widths: 900 and 1200 mm.  
Lengths: 1800, 2400, 2700 and 3000 mm.  
A 25 mm thickness is also produced, 600 mm wide × 3000 mm long.  
Plaster finished if required. Square or tapered edges.
5. Plank – used as fire protection for structural steel and timber, in addition to sound insulation in wall panels and floating floors.  
Thickness: 19 mm. Width: 600 mm.  
Lengths: 2350, 2400, 2700 and 3000 mm.  
Ivory face with grey back. Tapered edge.

#### NON-STANDARD PLASTERBOARDS:

1. Contour – only 6 mm in thickness to adapt to curved featurework. Width: 1200 mm. Lengths: 2400 mm and 3000 mm.
2. Vapourcheck – a metallized polyester wallboard lining to provide an integral water vapour control layer.  
Thicknesses: 9.5 and 12.5 mm. Widths: 900 and 1200 mm.  
Lengths: vary between 1800 and 3000 mm.
3. Thermalcheck – various expanded or foamed insulants are bonded to wallboard. Approximately 25–50 mm overall thickness in board sizes 1200 × 2400 mm.

## Plasterboard Fixing

Fixing ~ the detail below shows board fixing with nails or screws to timber battens. This is an alternative to using plaster dabs and pads shown on page 750.

Typical Fixing ~

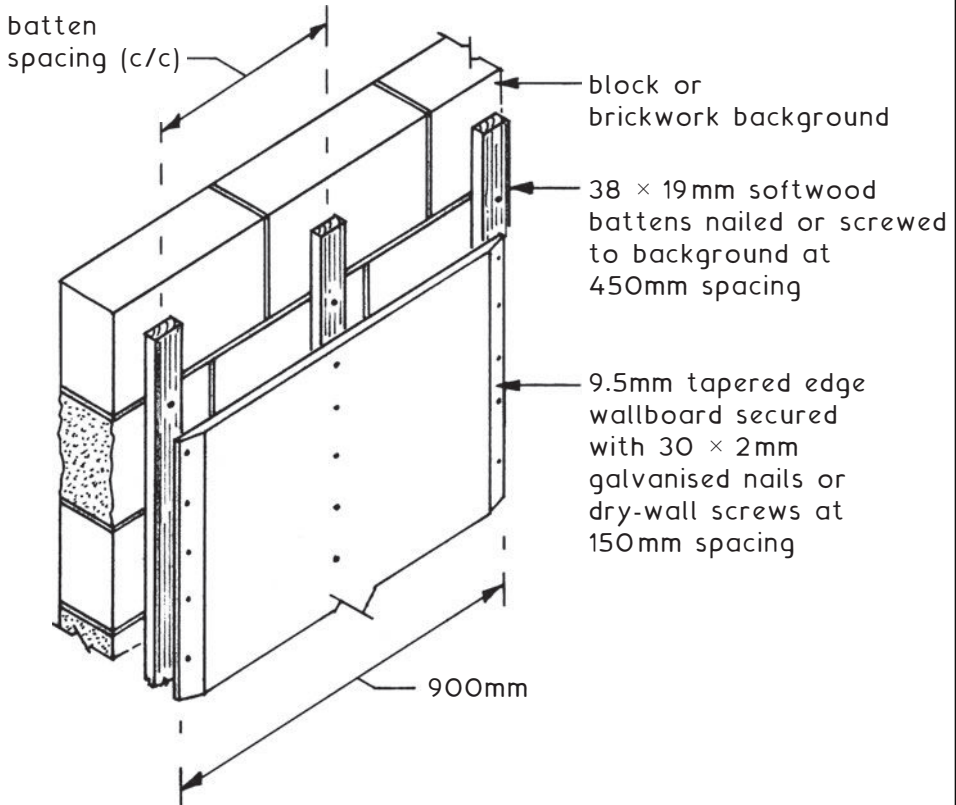

Guide to securing plasterboard to battens:

Board thickness (mm)	Board width (mm)	Batten spacing (mm)	Nail or dry-wall screw length (mm)
9.5	900	450	30
9.5	1200	400	30
12.5	600	600	40
12.5	900	450	40
19.0	600	600	60

Horizontal joints are avoided if possible with cross battens only required at the top and bottom to provide rigidity. Board fixing is with galvanised steel taper-head nails of 2mm diameter (2.6mm dia. for 19mm boards) or with dry-wall screws.

Jointing ~ boards should not directly abut, instead a gap of 3 to 5mm should be provided between adjacent boards for plaster filling and joint reinforcement tape. The illustrations show various applications.

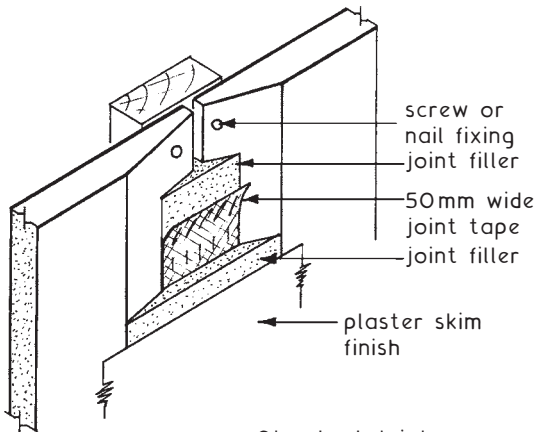

Standard Joint

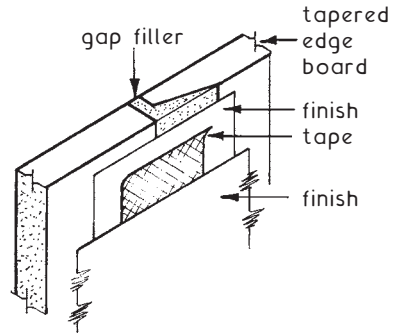

Cut Edge

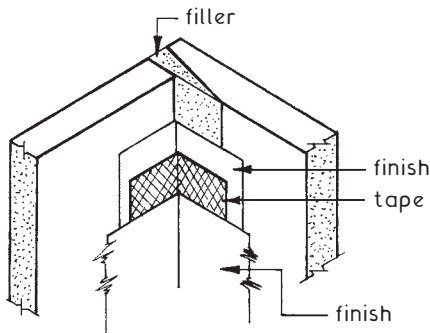

Internal Corner

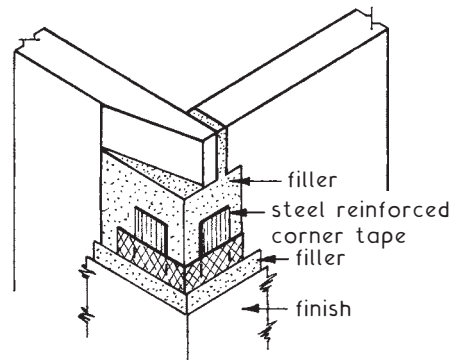

External Corner

NB. Paper jointing tape is generally specified for dry lining tapered edge boards. External corners are reinforced and strengthened with a particular type of tape that has two strips of thin steel attached.



## Wall Tiling

Glazed Wall Tiles ~ internal glazed wall tiles are usually made to the various specifications under BS EN 14411: Ceramic tiles. Definitions, classification, characteristics, evaluation of conformity and marking.

Internal Glazed Wall Tiles ~ the body of the tile can be made from ball-clay, china clay, china stone, flint and limestone. The material is usually mixed with water to the desired consistency, shaped and then fired in a tunnel oven at a high temperature (1150°C) for several days to form the unglazed biscuit tile. The glaze pattern and colour can now be imparted onto to the biscuit tile before the final firing process at a temperature slightly lower than that of the first firing (1050°C) for about two days.

Typical Internal Glazed Wall Tiles and Fittings:

Sizes - Modular	100 × 100 × 5mm thick and 200 × 100 × 6.5mm thick.
Non-modular	152 × 152 × 5 to 8mm thick and 108 × 108 × 4 and 6.5mm thick.

Other sizes - 200 × 300, 250 × 330, 250 × 400, 300 × 450, 300 × 600 and 330 × 600mm.

Fittings - wide range available particularly in the non-modular format.

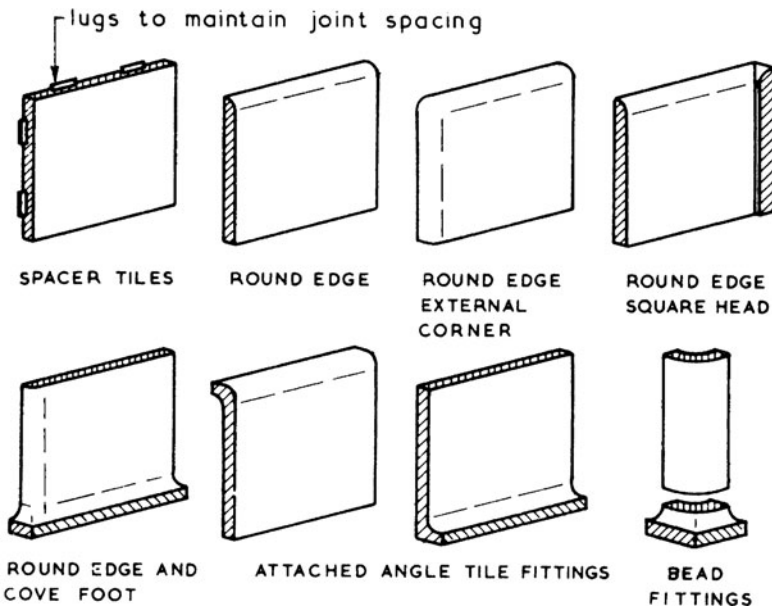

Bedding of Internal Wall Tiles ~ generally glazed internal wall tiles are considered to be inert in the context of moisture and thermal movement, therefore if movement of the applied wall tile finish is to be avoided attention must be given to the background and the method of fixing the tiles.

Backgrounds ~ these are usually of a cement rendered or plastered surface and should be flat, dry, stable, firmly attached to the substrate and sufficiently established for any initial shrinkage to have taken place. The flatness of the background should be not more than 3mm in 2·000 for the thin bedding of tiles and not more than 6mm in 2·000 for thick bedded tiles.

Fixing Wall Tiles ~ two methods are in general use:

1. Thin Bedding - lightweight internal glazed wall tiles fixed dry using a recommended adhesive which is applied to the wall in small areas 1m<sup>2</sup> at a time with a notched trowel, the tile being pressed into the adhesive.
2. Thick Bedding - cement mortar within the mix range of 1:3 to 1:4 can be used or a proprietary adhesive, either by buttering the backs of the tiles which are then pressed into position or by rendering the wall surface to a thickness of approximately 10mm and then applying thin bedded tiles to the rendered wall surface within two hours.

Grouting ~ when the wall tiles have set, the joints can be grouted by rubbing into the joints a grout paste either using a sponge or brush. Most grouting materials are based on cement with inert fillers and are used neat.

Typical Example ~

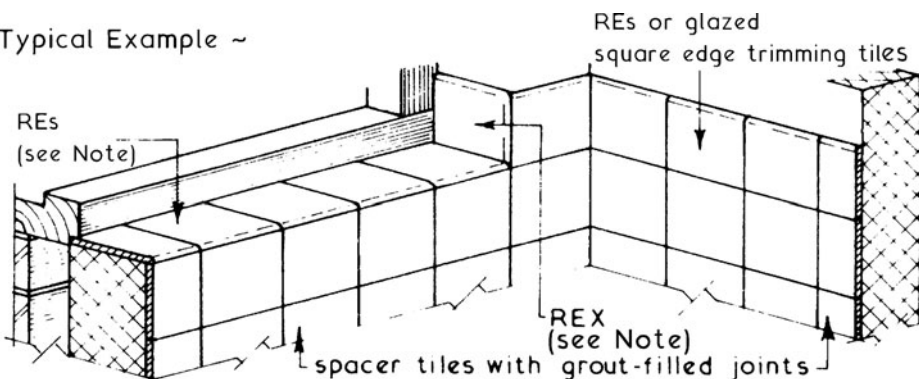

Note: The alternative treatment at edges is application of a radiused profile plastic trimming to standard spacer tiles.

# Domestic Ground Floors

## Primary Functions:

1. Provide a level surface with sufficient strength to support the imposed loads of people and furniture.
2. Exclude the passage of water and water vapour to the interior of the building.
3. Provide resistance to unacceptable heat loss through the floor.
4. Provide the correct type of surface to receive the chosen finish.

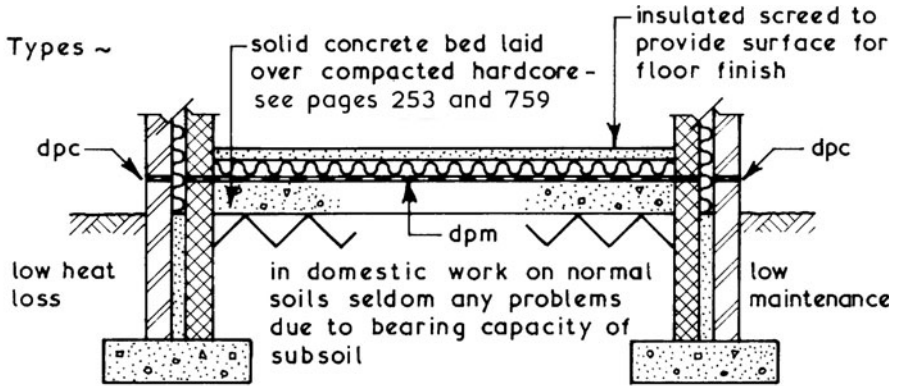

SOLID FLOOR ON LEVEL SITE

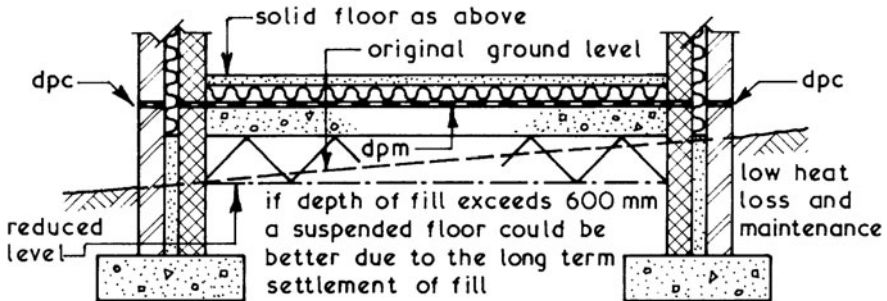

SOLID FLOOR ON SLOPING SITE

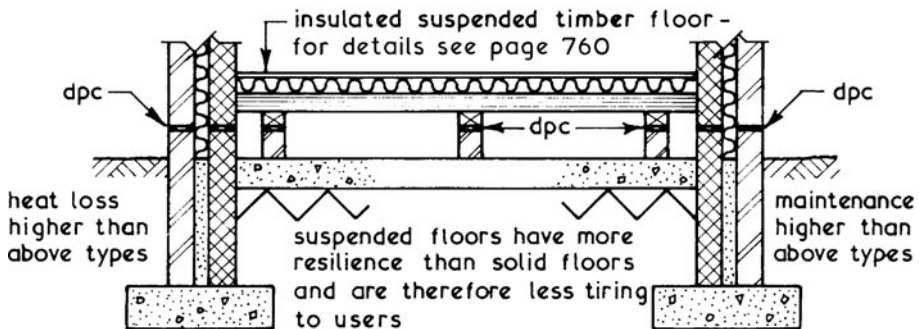

SUSPENDED TIMBER FLOOR

This drawing should be read in conjunction with page 253 - Foundation Beds.

A domestic solid ground floor consists of three components:

1. Hardcore - a suitable filling material to make up the top soil removal and reduced level excavations. It should have a top surface which can be rolled out to ensure that cement grout is not lost from the concrete. It may be necessary to blind the top surface with a layer of sand especially if the damp-proof membrane is to be placed under the concrete bed.
2. Damp-proof Membrane - an impervious layer such as heavy duty polythene sheeting to prevent moisture from passing through the floor to the interior of the building.
3. Concrete Bed - the component providing the solid level surface to which screeds and finishes can be applied.

Typical Details ~

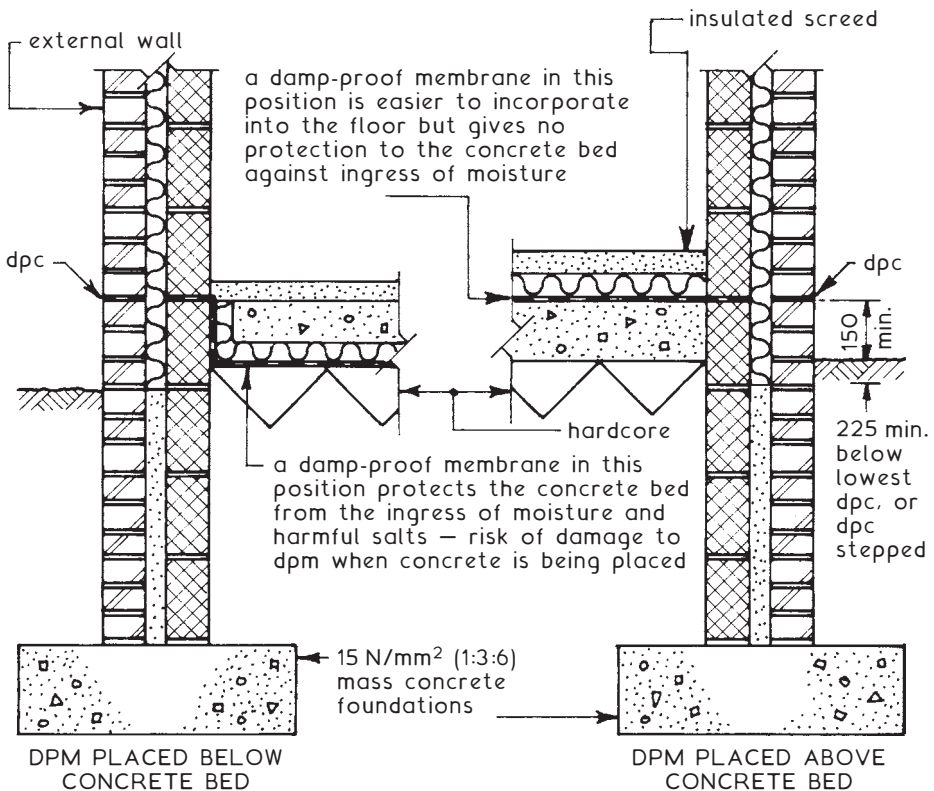

NB. a compromise to the above methods is to place the dpm in the middle of the concrete bed but this needs two concrete pouring operations.

# Domestic Suspended Timber Ground Floors

Suspended Timber Ground Floors ~ these need to have a well-ventilated space beneath the floor construction to prevent the moisture content of the timber from rising above an unacceptable level (i.e. not more than 20%) which would create the conditions for possible fungal attack.

Typical Details ~

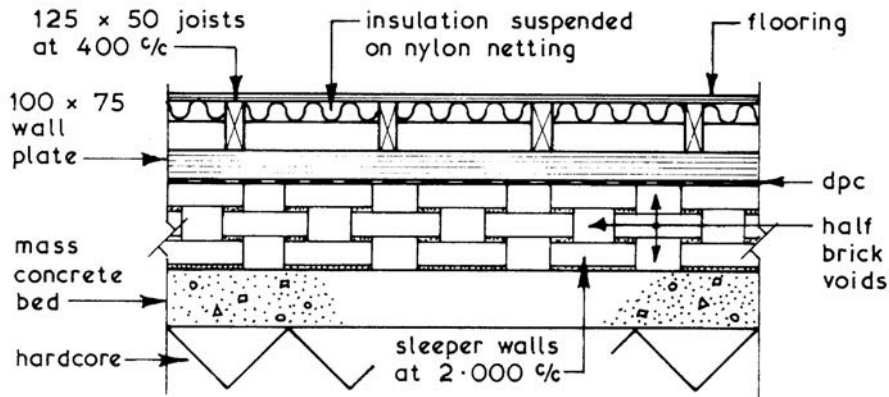
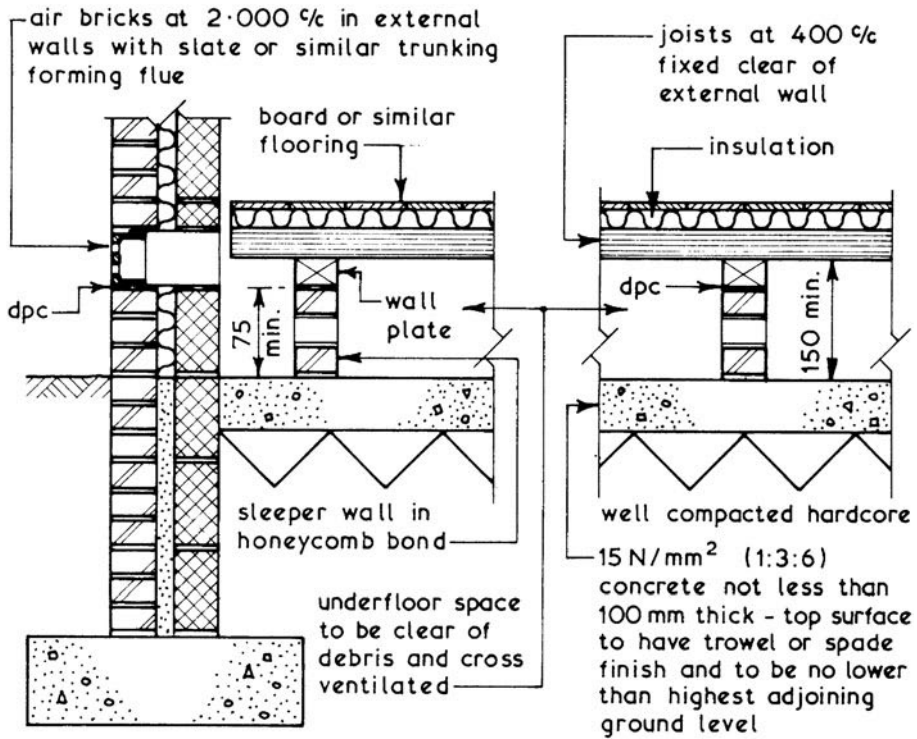

ELEVATION OF SLEEPER WALL

# Domestic Suspended Concrete Ground Floors

Precast Concrete Floors ~ these have been successfully adapted from commercial building practice (see pages 789 and 790), as an economic alternative construction technique for suspended timber and solid concrete domestic ground (and upper) floors. See also page 416 for special situations.

Typical Details ~

## BEAMS PARALLEL WITH EXTERNAL WALL

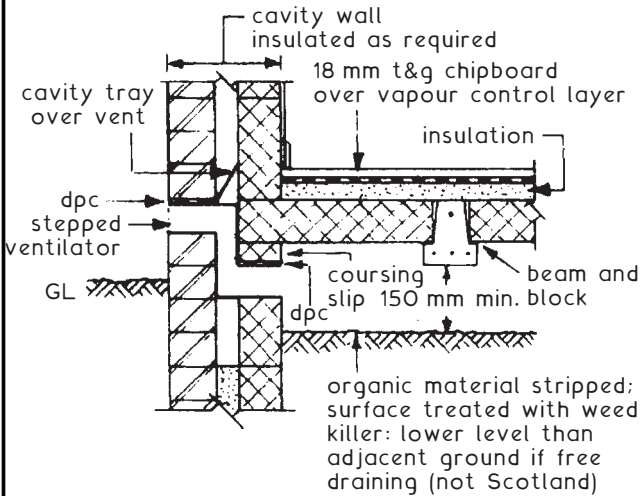

## POLYPROPYLENE VENTILATOR

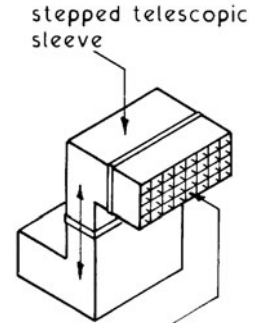

grill clips to sleeve:  
 $1500\text{mm}^2/\text{m}$  run of wall OR  $500\text{mm}^2/\text{m}^2$  of floor area (take greater value)

lightweight concrete block, min.  $7\text{N}/\text{mm}^2$

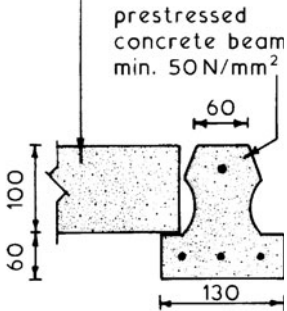

TYPICAL BEAM/RIB AND BLOCK DETAIL

## BEAMS BEARING ON EXTERNAL WALL

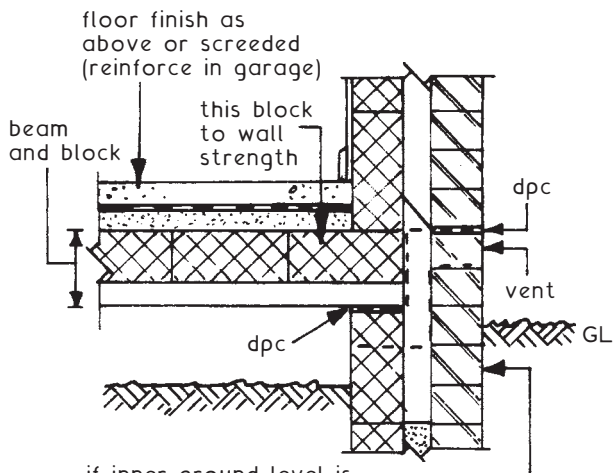

if inner ground level is significantly lower, this area to be designed as a retaining wall

# Domestic Suspended Concrete Ground Floor and Walls

Perspective ~

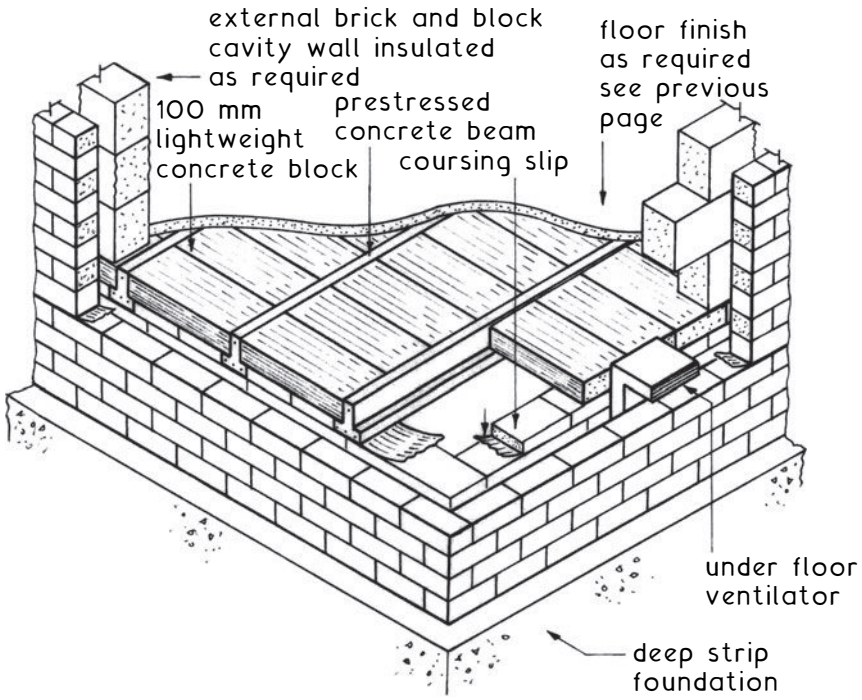

Internal Wall Support to Staggered Beams ~

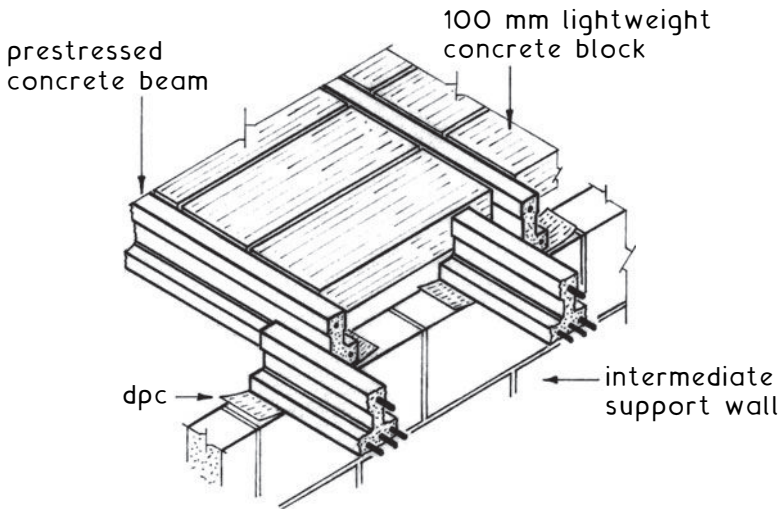

## Domestic Suspended Concrete and EPS Ground Floors

Precast Reinforced Concrete Beam and Expanded Polystyrene (EPS) Block Floors ~ these have evolved from the principles of beam and block floor systems as shown on the preceding page. The lightweight and easy to cut properties of the blocks provide for speed and simplicity in construction. Exceptional thermal insulation is possible, with U-values as low as  $0.2 \text{ W/m}^2\text{K}$ .

Typical Detail ~

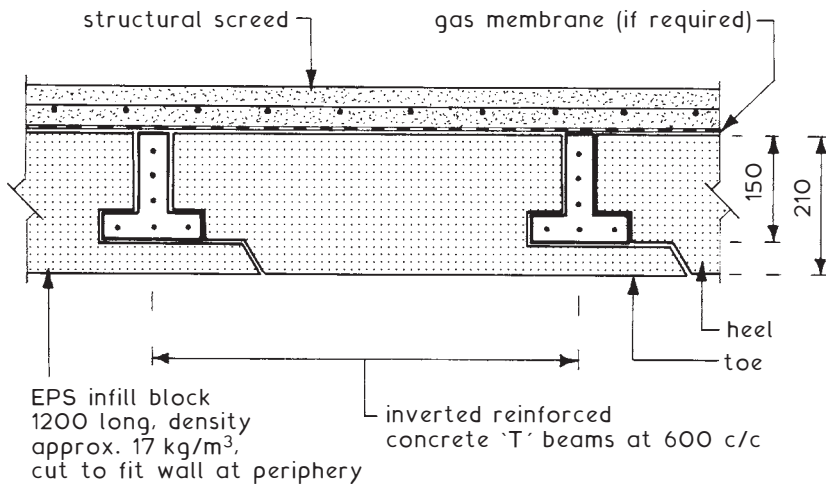

Cold Bridging ~ this is prevented by the EPS 'toe' projecting beneath the underside of the concrete beam.

Structural Floor Finish ~ 50 mm structural concrete (C30 grade) screed, reinforced with 10 mm steel Type A square mesh or with polypropylene fibres in the mix. A low-density polyethylene (LDPE) methane/radon gas membrane can be incorporated under the screed if local conditions require it.

Floating Floor Finish ~ subject to the system manufacturer's specification and accreditation, 18 mm flooring grade moisture-resistant chipboard can be used over a 1000 gauge polythene vapour control layer. All four tongued and grooved edges of the chipboard are glued for continuity.



## Domestic Floor Finishes

Floor Finishes ~ these are usually applied to a structural base but may form part of the floor structure as in the case of floor-boards. Most finishes are chosen to fulfil a particular function such as:

1. Appearance - chosen mainly for their aesthetic appeal or effect but should however have reasonable wearing properties. Examples are carpets, carpet tiles and wood blocks.
2. High Resistance - chosen mainly for their wearing and impact-resistance properties and for high usage areas such as kitchens. Examples are quarry tiles and granolithic pavings.
3. Hygiene - chosen to provide an impervious easy to clean surface with reasonable aesthetic appeal. Examples are quarry tiles and polyvinyl chloride (PVC) sheets and tiles.

Carpets and Carpet Tiles - made from animal hair, mineral fibres and man made fibres such as nylon and acrylic. They are also available in mixtures of the above. A wide range of patterns, sizes and colours are available. Carpets and carpet tiles can be laid loose, stuck with a suitable adhesive or in the case of carpets edge fixed using special grip strips.

PVC Tiles - made from a blended mix of thermoplastic binders; fillers and pigments in a wide variety of colours and patterns to the recommendations of BS EN 649: Resilient floor coverings. PVC tiles are usually 305 × 305 × 1.6 mm thick and are stuck to a suitable base with special adhesives as recommended by the manufacturer.

Quarry Tiles ~

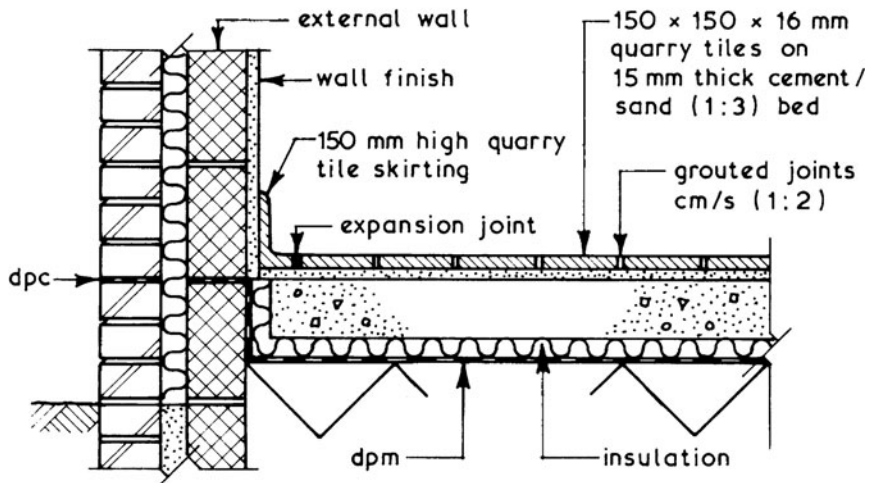

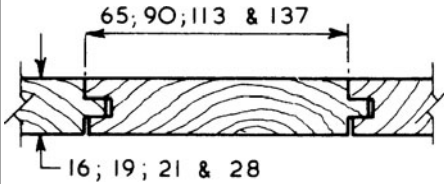

Tongue and Groove Boarding ~ prepared from softwoods to the recommendations of BS 1297. Boards are laid at right angles to the joists and are fixed with 2 No. 65 mm long cut floor brads per joists. The ends of board lengths are butt jointed on the centre line of the supporting joist.

Maximum board spans are:

16 mm thick - 505 mm

19 mm thick - 600 mm

21 mm thick - 635 mm

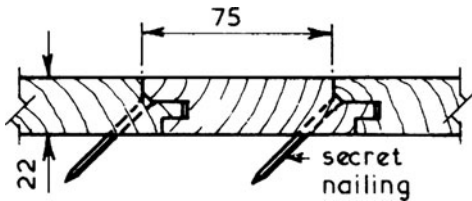

Timber Strip Flooring ~ strip flooring is usually considered to be boards under 100 mm face width. In good class work hardwoods would be specified, the boards being individually laid and secret nailed. Strip flooring can be obtained treated with a spirit-based fungicide. Spacing of supports depends on type of timber used and applied loading. After laying the strip flooring it should be finely sanded and treated with a seal or wax. In common with all timber floorings a narrow perimeter gap should be left for moisture movement.

Chipboard ~ sometimes called Particle Board is made from particles of wood bonded with a synthetic resin and/or other organic binders to the recommendations of BS EN 319.

Standard floorboards are in lengths up to 2400mm, a width of 600mm x 18 or 22mm thickness with tongued and grooved joints to all edges. Laid at right angles to joists with all cross joints directly supported. May be specified as unfinished or water proof quality indicated with a dull green dye.

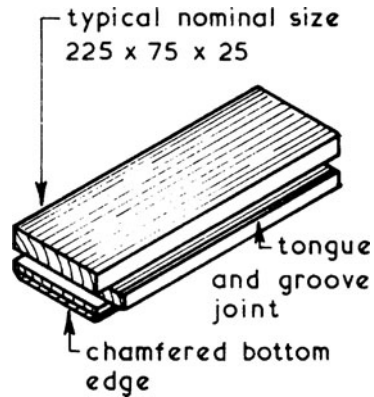

Wood Blocks ~ prepared from hardwoods and softwoods to the recommendations of BS 1187. Wood blocks can be laid to a variety of patterns, also different timbers can be used to create colour and grain effects. Laid blocks should be finely sanded and sealed or polished.

## Large Cast In-situ Ground Floors

Large Cast-In-situ Ground Floors ~ these are floors designed to carry medium to heavy loadings such as those used in factories, warehouses, shops, garages and similar buildings. Their design and construction is similar to that used for small roads (see pages 165 and 166). Floors of this type are usually laid in alternate 4.500 wide strips running the length of the building or in line with the anticipated traffic flow where applicable. Transverse joints will be required to control the tensile stresses due to the thermal movement and contraction of the slab. The spacing of these joints will be determined by the design and the amount of reinforcement used. Such joints can either be formed by using a crack inducer or by sawing a 20 to 25 mm deep groove into the upper surface of the slab within 20 to 30 hours of casting.

Typical Layout ~

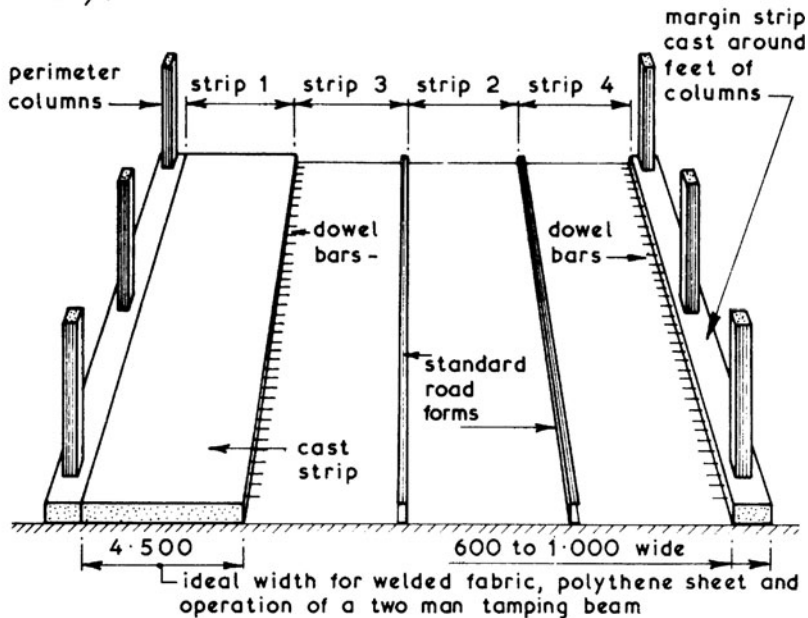

Surface Finishing ~ the surface of the concrete may be finished by power floating or trowelling which is carried out whilst the concrete is still plastic but with sufficient resistance to the weight of machine and operator whose footprint should not leave a depression of more than 3 mm. Power grinding of the surface is an alternative method which is carried out within a few days of the concrete hardening. The wet concrete having been surface finished with a skip float after the initial levelling with a tamping bar has been carried out. Power grinding removes 1 to 2 mm from the surface and is intended to improve surface texture and not to make good deficiencies in levels.

## Large Cast In-situ Ground Floors

Vacuum Dewatering ~ if the specification calls for a power float surface finish vacuum dewatering could be used to shorten the time delay between tamping the concrete and power floating the surface. This method is suitable for slabs up to 300 mm thick. The vacuum should be applied for approximately three minutes for every 25 mm depth of concrete which will allow power floating to take place usually within 20 to 30 minutes of the tamping operation. The applied vacuum forces out the surplus water by compressing the slab and this causes a reduction in slab depth of approximately 2%; therefore packing strips should be placed on the side forms before tamping to allow for sufficient surcharge of concrete.

Typical Details ~

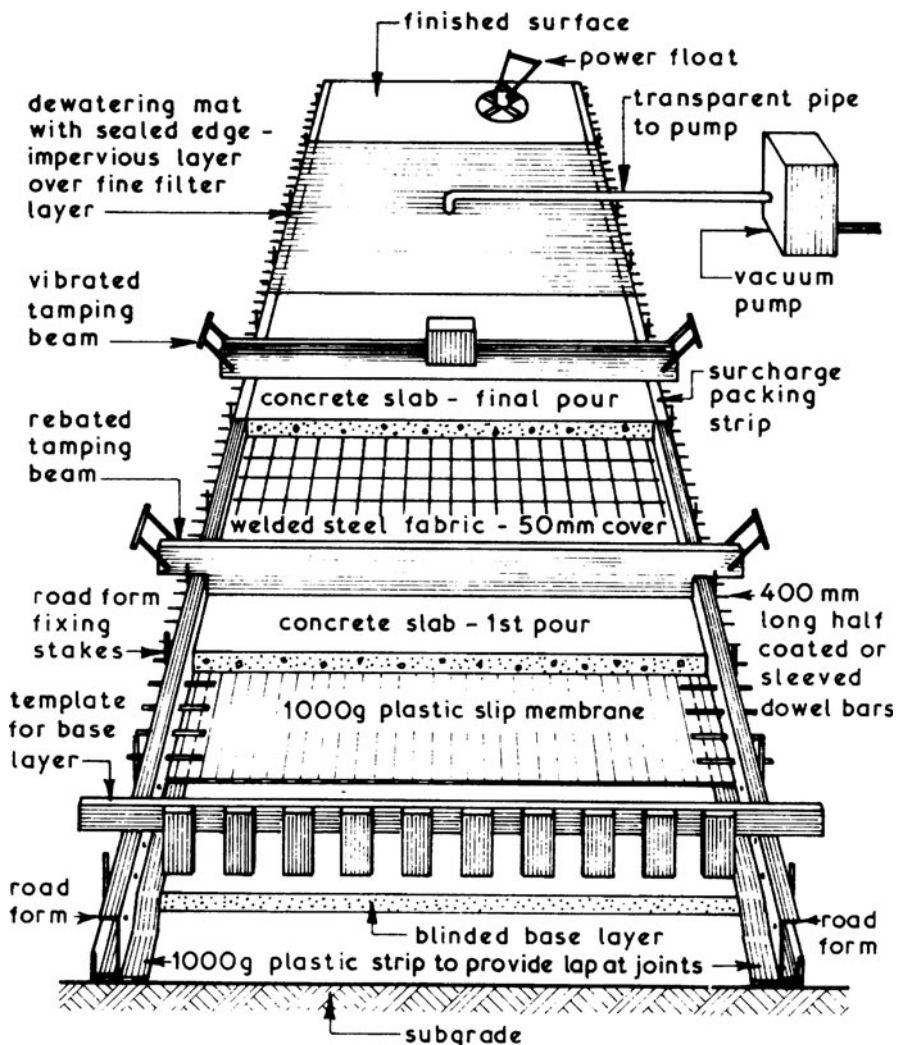

## Concrete Floor Screeds

Concrete Floor Screeds ~ these are used to give a concrete floor a finish suitable to receive the floor finish or covering specified. It should be noted that it is not always necessary or desirable to apply a floor screed to receive a floor covering. Techniques are available to enable the concrete floor surface to be prepared at the time of casting to receive the coverings at a later stage.

Typical Screed Mixes ~

Screed Thickness	Cement	Dry Fine Aggregate <5 mm	Coarse Aggregate >5 mm <10 mm
up to 40 mm	1	3 to 4 1/2	-
40 to 75 mm	1	3 to 4 1/2	-
	1	1 1/2	3

Laying Floor Screeds ~ floor screeds should not be laid in bays since this can cause curling at the edges. Screeds can however be laid in 3.000 wide strips to receive thin coverings. Levelling of screeds is achieved by working to levelled timber screeding batten or alternatively a 75 mm wide band of levelled screed with square edges can be laid to the perimeter of the floor prior to the general screed-laying operation.

Screed Types ~

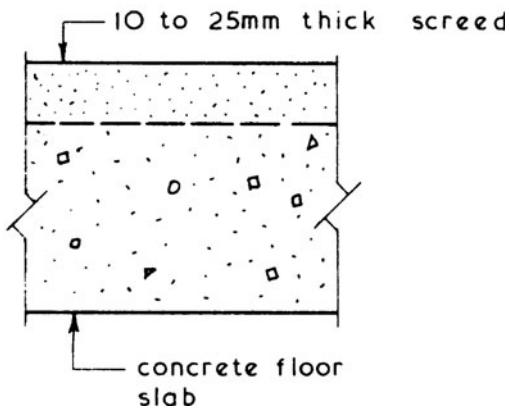

Monolithic Screeds -

screed laid directly on concrete floor slab within three hours of placing concrete - before any screed is placed all surface water should be removed - all screeding work should be carried out from scaffold board runways to avoid walking on the 'green' concrete slab.

Screed Types ~

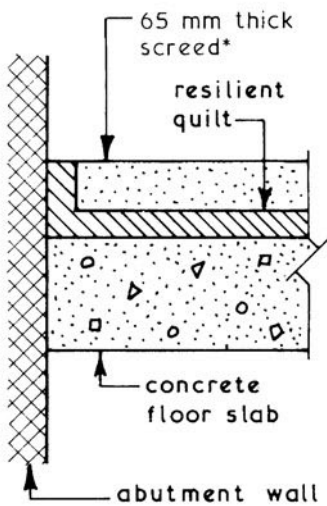
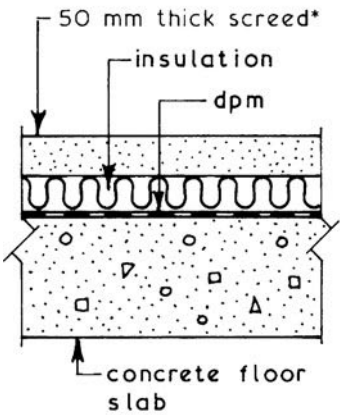
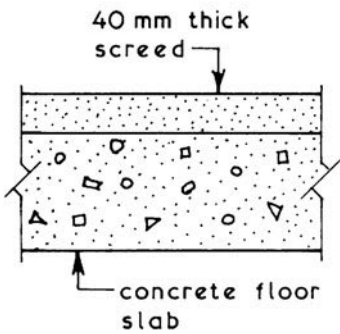

\*preferably wire mesh reinforced.

Separate Screeds -

screed is laid onto the concrete floor slab after it has cured. The floor surface must be clean and rough enough to ensure an adequate bond unless the floor surface is prepared by applying a suitable bonding agent or by brushing with a cement/water grout of a thick cream-like consistency just before laying the screed.

Unbonded Screeds -

screed is laid directly over a damp-proof membrane or over a damp-proof membrane and insulation. A rigid form of floor insulation is required where the concrete floor slab is in contact with the ground. Care must be taken during this operation to ensure that the damp-proof membrane is not damaged.

Floating Screeds -

a resilient quilt of 25 mm thickness is laid with butt joints and turned up at the edges against the abutment walls, the screed being laid directly over the resilient quilt. The main objective of this form of floor screed is to improve the sound insulation properties of the floor.

## Latex Floor Screeds

Latex ~ a naturally occurring liquid from some plants, notably the rubber tree. Synthetic latexes are now produced from polymers and resins.

Latex Floor Screed ~ a modified screed, originally created by including particles of rubber or bitumen with cement and sand to achieve a hard-wearing, dust-free, impervious and easily maintained floor finish. Suitable in factories and public places such as schools. Contemporary latex screeds can include rubber and bitumen for industrial applications along with granite chippings for increased depth. Most latex screeds now have liquid resin or synthetic polymer additives to modify the cement and sand. These permit spreading in very thin layers and are ideal for levelling uneven and irregular surfaces of sound composition. The ease of use and workability has led to the term 'self-levelling screeds', which is not entirely correct, as they do require physical spreading and trowelling to a finish.

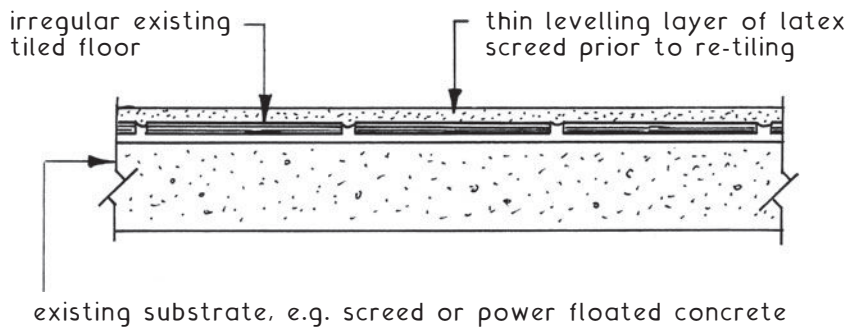

Availability ~ one or two part packs.

Single packs are dry based, premixed materials in 20 or 25 kg bags for the addition of water on site. Application is in 3 to 8 mm thickness. Some single packs are available with granite chippings for applications up to 25 mm in thickness.

Two part packs consist of a cement and sand based powder in 20 or 25 kg bags for use with a 5 kg container of liquid emulsion, usually of styrene-polymer composition. After mixing, up to a 12 mm thickness can be applied and up to 30 mm with a coarse sand aggregate.

## Primary Functions:

1. Provide a level surface with sufficient strength to support the imposed loads of people and furniture plus the dead loads of flooring and ceiling.
2. Reduce heat loss from lower floor as required.
3. Provide required degree of sound insulation.
4. Provide required degree of fire resistance.

Basic Construction - a timber suspended upper floor consists of a series of beams or joists supported by load bearing walls sized and spaced to carry all the dead and imposed loads.

Joist Sizing - three methods can be used:

<p>1. Building Regs. Approved Document A - Structure. Refs. *BS 6399-1: Code of practice for dead and imposed loads (min. 1.5 kN/m<sup>2</sup> distributed, 1.4 kN concentrated). *TRADA publication - Span Tables for Solid Timber Members in Dwellings.</p>	<p>2. Calculation formula:</p> $BM = \frac{fbd^2}{6}$ <p>where                  BM = bending moment                  f = fibre stress                  b = breadth                  d = depth in mm must be assumed</p>	<p>3. Empirical formula:</p> $D = \frac{\text{span in mm}}{24} + 50$ <p>where                  D = depth of joist in mm</p> <p>above assumes that joists have a breadth of 50 mm and are at 400% spacing</p>
---	---	--

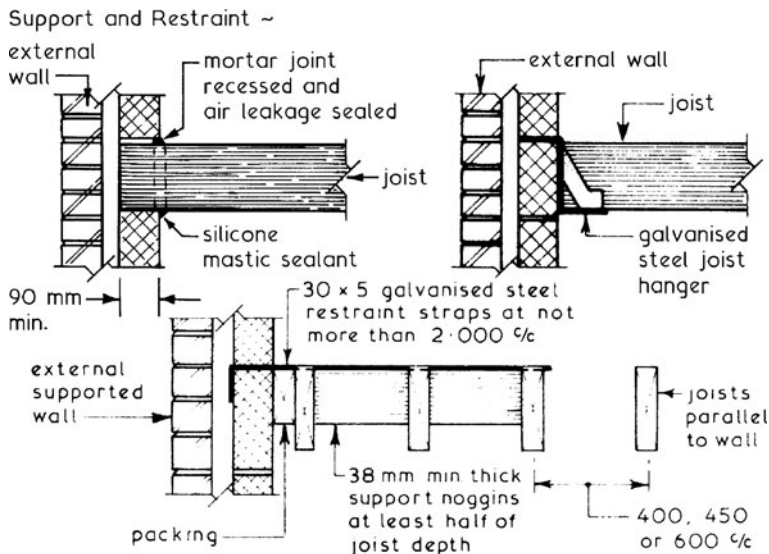



# Timber Suspended Upper Floors

Strutting ~ used in timber suspended floors to restrict the movements due to twisting and vibration which could damage ceiling finishes. Strutting should be included if the span of the floor joists exceeds 2.5m and is positioned on the centre line of the span. Max. floor span ~ 6m measured centre to centre of bearing (inner leaf centre line in cavity wall).

## Typical Details ~

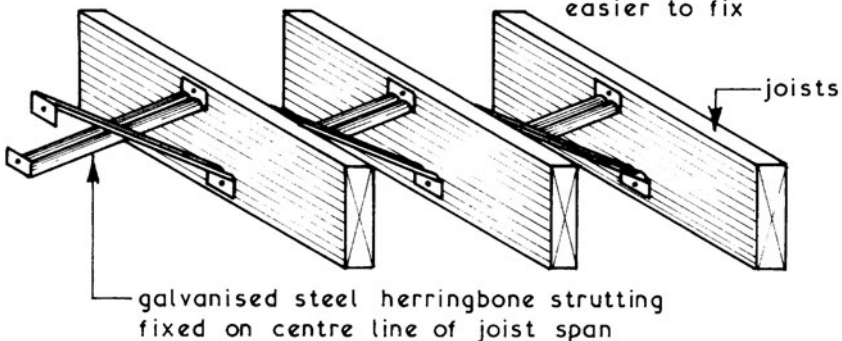
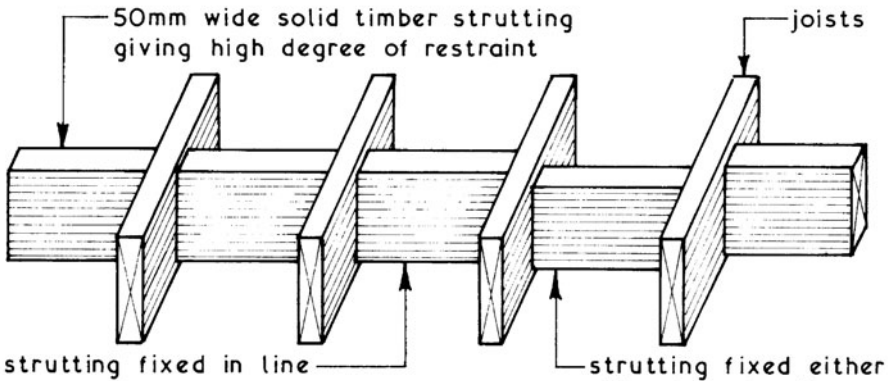
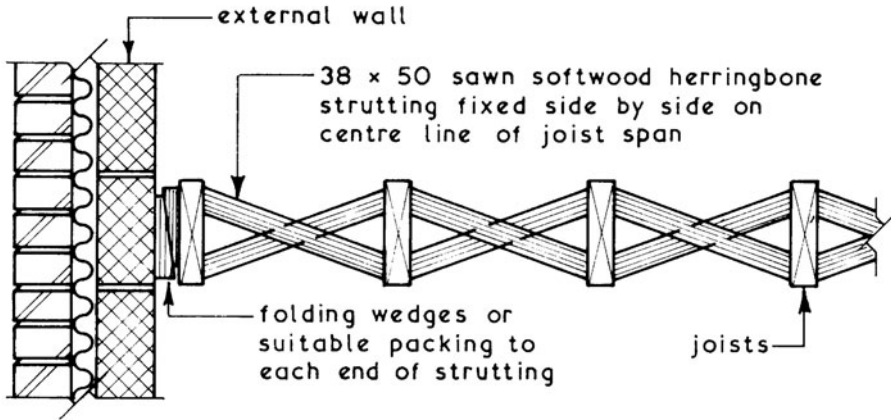

Lateral Restraint ~ external, compartment (fire), separating (party) and internal load bearing walls must have horizontal support from adjacent floors, to restrict movement. Exceptions occur when the wall is less than 3m long.

Methods:

1. 90 mm end bearing of floor joists, spaced not more than 1.2m apart – see page 771.
2. Galvanised steel straps spaced at intervals not exceeding 2m and fixed square to joists – see page 771.

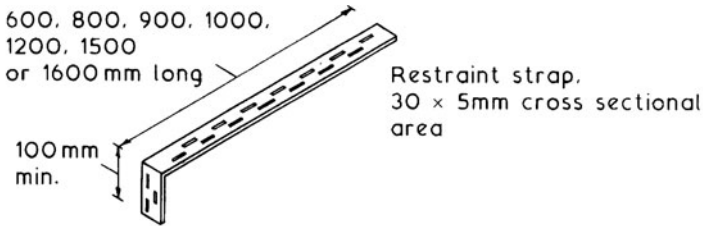

3. Joists carried by BS approved galvanised steel hangers.

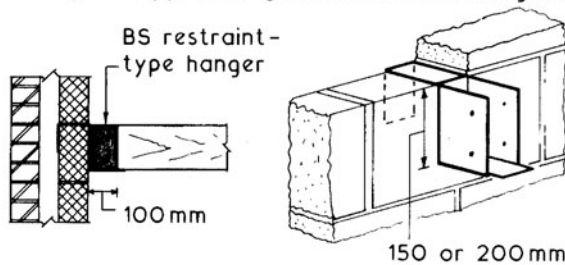

4. Adjacent floors at or about the same level, contacting with the wall at no more than 2 m intervals.

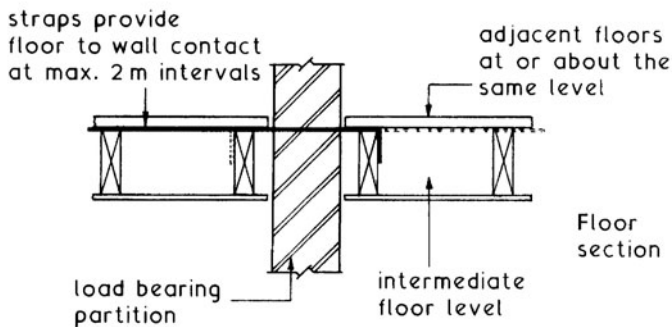

Ref. BS EN 845-1: Specification for ancillary components for masonry. Wall ties, tension straps, hangers and brackets.

# Lateral Restraint – Retro-ties

Wall Stability - at right angles to floor and ceiling joists this is achieved by building the joists into masonry support walls or locating them on approved joist hangers.

Walls parallel to joists are stabilised by lateral restraint straps. Buildings constructed before current stability requirements (see Bldg. Regs. A.D; A - Structure) often show signs of wall bulge due to the effects of eccentric loading and years of thermal movement.

## Remedial Measures –

### Retro-strap

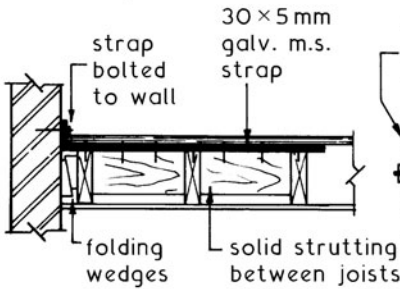

### Retro-stud

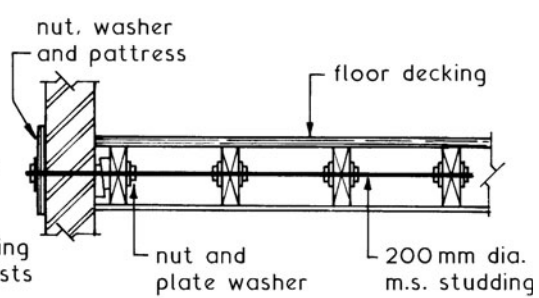

### Through tie

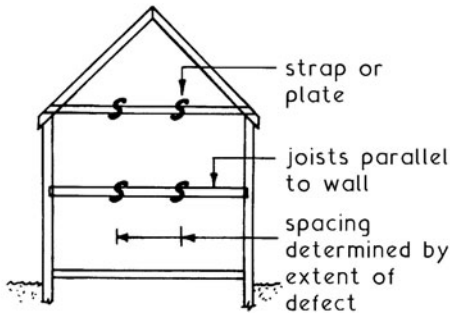
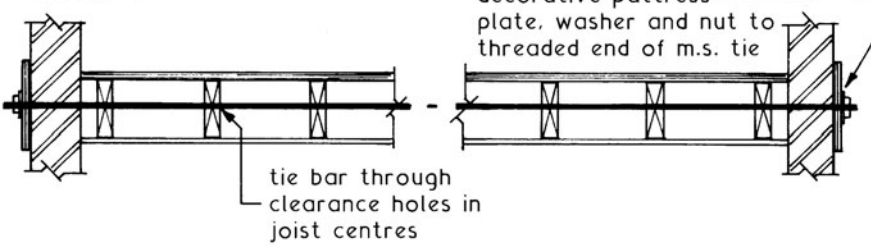

Location of straps and ties

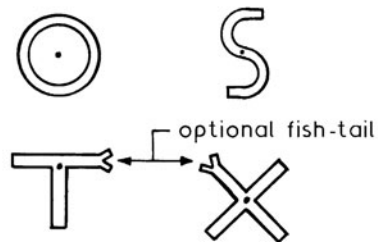

Common decorative iron pattress plates and straps

# Timber Suspended Upper Floors – Trimming

Trimming Members ~ these are the edge members of an opening in a floor and are the same depth as common joists but are usually 25 mm wider.

Typical Details ~

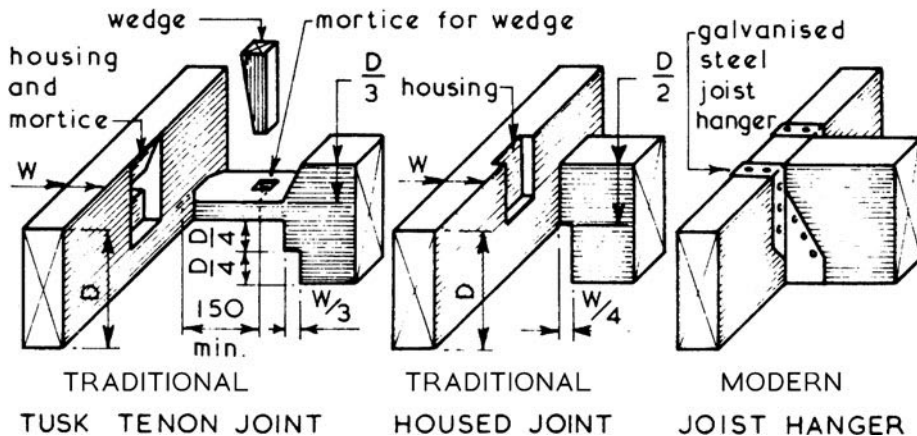
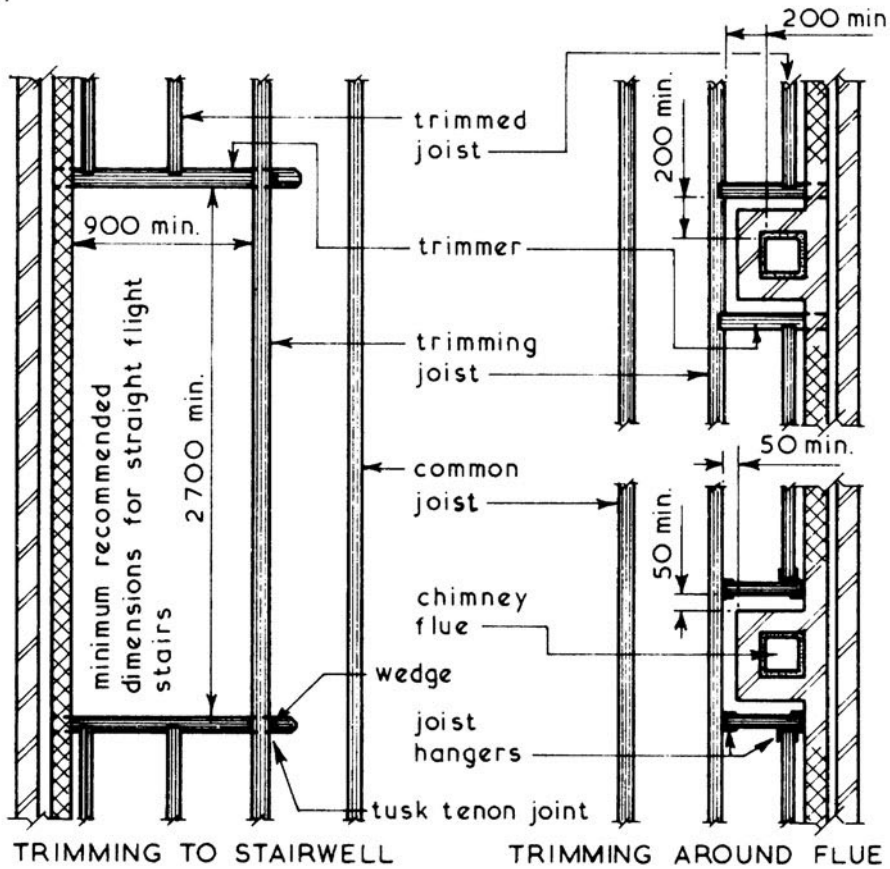

## Timber Suspended Upper Floors – Joist Sizes

Typical spans and loading for floor joists of general structural (GS) grade:

Sawn size (mm × mm)	Dead weight of flooring and ceiling, excluding the self-weight of the joists (kg/m <sup>2</sup> )								
	< 25			25-50			50-125		
	Spacing of joists (mm c/c)								
	400	450	600	400	450	600	400	450	600
	Maximum clear span (m)								
38 × 75	1.22	1.09	0.83	1.14	1.03	0.79	0.98	0.89	0.70
38 × 100	1.91	1.78	1.38	1.80	1.64	1.28	1.49	1.36	1.09
38 × 125	2.54	2.45	2.01	2.43	2.30	1.83	2.01	1.85	1.50
38 × 150	3.05	2.93	2.56	2.91	2.76	2.40	2.50	2.35	1.93
38 × 175	3.55	3.40	2.96	3.37	3.19	2.77	2.89	2.73	2.36
38 × 200	4.04	3.85	3.35	3.82	3.61	3.13	3.27	3.09	2.68
38 × 225	4.53	4.29	3.73	4.25	4.02	3.50	3.65	3.44	2.99
50 × 75	1.45	1.37	1.08	1.39	1.30	1.01	1.22	1.11	0.88
50 × 100	2.18	2.06	1.76	2.06	1.95	1.62	1.82	1.67	1.35
50 × 125	2.79	2.68	2.44	2.67	2.56	2.28	2.40	2.24	1.84
50 × 150	3.33	3.21	2.92	3.19	3.07	2.75	2.86	2.70	2.33
50 × 175	3.88	3.73	3.38	3.71	3.57	3.17	3.30	3.12	2.71
50 × 200	4.42	4.25	3.82	4.23	4.07	3.58	3.74	3.53	3.07
50 × 225	4.88	4.74	4.26	4.72	4.57	3.99	4.16	3.94	3.42
63 × 100	2.41	2.29	2.01	2.28	2.17	1.90	2.01	1.91	1.60
63 × 125	3.00	2.89	2.63	2.88	2.77	2.52	2.59	2.49	2.16
63 × 150	3.59	3.46	3.15	3.44	3.31	3.01	3.10	2.98	2.63
63 × 175	4.17	4.02	3.66	4.00	3.85	3.51	3.61	3.47	3.03
63 × 200	4.73	4.58	4.18	4.56	4.39	4.00	4.11	3.95	3.43
63 × 225	5.15	5.01	4.68	4.99	4.85	4.46	4.62	4.40	3.83
75 × 125	3.18	3.06	2.79	3.04	2.93	2.67	2.74	2.64	2.40
75 × 150	3.79	3.66	3.33	3.64	3.50	3.19	3.28	3.16	2.86
75 × 175	4.41	4.25	3.88	4.23	4.07	3.71	3.82	3.68	3.30
75 × 200	4.92	4.79	4.42	4.77	4.64	4.23	4.35	4.19	3.74
75 × 225	5.36	5.22	4.88	5.20	5.06	4.72	4.82	4.69	4.16

Notes:

1. Where a bath is supported, the joists should be duplicated.
2. See pages 38 and 39 for material dead weights.
3. See pages 141 and 142 for softwood classification and grades.

Joist and Beam Sizing ~ design tables and formulae have limitations, therefore where loading, span and/or conventional joist spacings are exceeded, calculations are required. BS EN 1995-1-1: Design of timber structures and BS EN 338: Structural timber – strength classes are both useful resource material for detailed information on a variety of timber species. The following example serves to provide guidance on the design process for determining joist size, measurement of deflection, safe bearing and resistance to shear force:

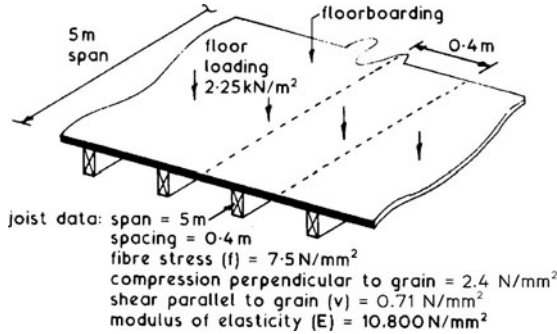

Total load (W) per joist = 5 m × 0.4 m × 2.25 kN/m<sup>2</sup> = 4.5 kN

$$\text{or : } \frac{4.5 \text{ kN}}{5 \text{ m span}} = 0.9 \text{ kN/m}$$

Resistance to bending ~

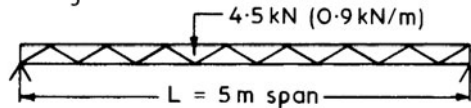

Bending moment formulae are shown on pages 640 and 643

$$BM = \frac{WL}{8} = \frac{fbd^2}{6}$$

Where: W = total load, 4.5 kN (4500 N)

L = span, 5m (5000 mm)

f = fibre stress of timber, 7.5 N/mm<sup>2</sup>

b = breadth of joist, try 50 mm

d = depth of joist, unknown

Transposing:

$$\frac{WL}{8} = \frac{fbd^2}{6}$$

Becomes:

$$d = \sqrt{\frac{6WL}{8fb}} = \sqrt{\frac{6 \times 4500 \times 5000}{8 \times 7.5 \times 50}} = 212 \text{ mm}$$

Nearest commercial size: 50 mm × 225 mm

## Timber Beam Design

Joist and Beam Sizing ~ calculating overall dimensions alone is insufficient. Checks should also be made to satisfy: resistance to deflection, adequate safe bearing and resistance to shear.

Deflection - should be minimal to prevent damage to plastered ceilings. An allowance of up to  $0.003 \times \text{span}$  is normally acceptable; for the preceding example this will be:

$$0.003 \times 5000 \text{ mm} = 15 \text{ mm}$$

The formula for calculating deflection due to a uniformly distributed load (see pages 642 and 643) is:

$$\frac{5WL^3}{384EI} \text{ where } I = \frac{bd^3}{12}$$

$$I = \frac{50 \times (225)^3}{12} = 4.75 \times (10)^7$$

$$\text{So, deflection} = \frac{5 \times 4500 \times (5000)^3}{384 \times 10800 \times 4.75 \times (10)^7} = 14.27 \text{ mm}$$

NB. This is only just within the calculated allowance of 15 mm, therefore it would be prudent to specify slightly wider or deeper joists to allow for unknown future use.

Safe Bearing ~

$$= \frac{\text{load at the joist end, } W/2}{\text{compression perpendicular to grain} \times \text{breadth}}$$

$$= \frac{4500/2}{2.4 \times 50} = 19 \text{ mm.}$$

therefore full support from masonry (90 mm min.) or joist hangers will be more than adequate.

Shear Strength ~

$$V = \frac{2bdv}{3}$$

where:  $V$  = vertical loading at the joist end,  $W/2$

$v$  = shear strength parallel to the grain,  $0.71 \text{ N/mm}^2$

Transposing:-

$$bd = \frac{3V}{2v} = \frac{3 \times 2250}{2 \times 0.71} = 4753 \text{ mm}^2 \text{ minimum}$$

$$\text{Actual } bd = 50 \text{ mm} \times 225 \text{ mm} = 11,250 \text{ mm}^2$$

Resistance to shear is satisfied as actual is well above the minimum.

## Typical Situations ~

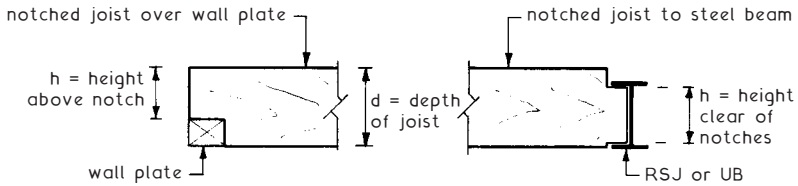

It is necessary to ensure enough timber above and/or below a notch to resist horizontal shear or shear parallel to the grain. To check whether a joist or beam has adequate horizontal shear strength:

$$v = (V3d) \div (2bh^2)$$

Using the data provided in the previous two pages as applied to the design of a timber joist of 225 × 50mm cross section, in this instance with a 50mm notch to leave 175mm (h) clear:

$$v = (2250 \times 3 \times 225) \div (2 \times 50 \times 175 \times 175) = 0.496 \text{ N/mm}^2$$

Shear strength parallel to the grain\* is given as 0.710N/mm<sup>2</sup> so sufficient strength is still provided.

\*see page 142.

## Bressummer (or breastsummer) beam ~

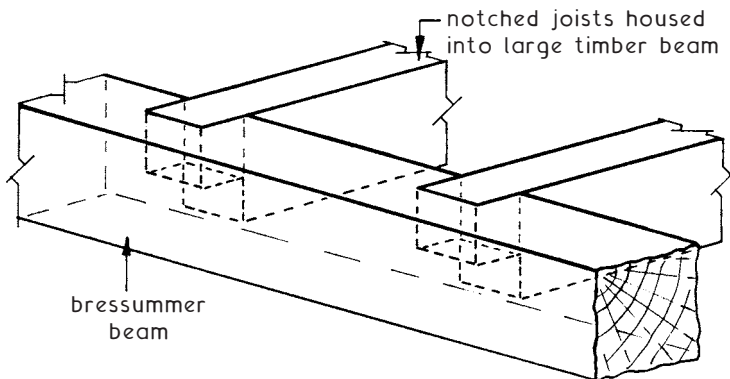

A long, large section timber beam carrying joists directly or notched and housed (as shown). A dated form of construction for supporting a masonry wall and floor/ceiling joists in large openings. Often found during refurbishment work over shop windows. Steel or reinforced concrete now preferred.



## Holing and Notching Joists for Pipes and Cables (1)

Pipes and cables ~ should be routed discretely and out of sight, but accessible for maintenance and repair. Where timber joists are used, services running parallel can be conveniently attached to the sides. At right angles the timber will need to be holed or notched.

Holing ~ suitable for flexible cables and coiled soft copper micro-bore tubing. The preferred location in simply supported end-bearing floor joists is in the neutral axis. This is where compressive and tensile load distribution neutralises at the centre and where the material gets neither longer nor shorter when deflected.

Joist under load

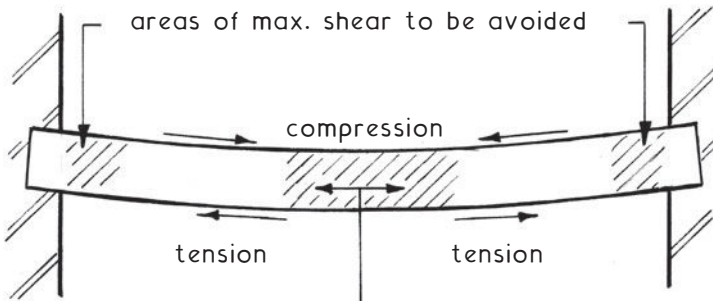

area of max. compression and bending to be avoided

Load variation

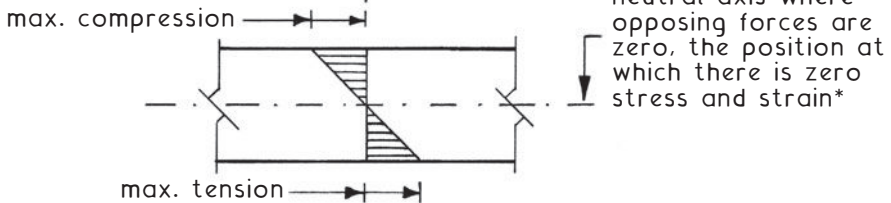

\*stress is represented by: loading ÷ cross sectional area

strain is represented by: extension ÷ original length

NB. The relationship between stress and strain is most obvious with metals and plastics. When these are deformed by an applied force they return to their original size and shape after the force is removed. The two physical states of stress and strain are proportional within the elastic state just described. This is known as Hooke's Law and is described by the term elasticity measured in units of  $N/mm^2$ . Examples for softwood timber are given on page 142.

## Holing and Notching Joists for Pipes and Cables (2)

Hole limitations ~

Diameter maximum:  $0.25 \times$  joist depth.

Spacing minimum:  $3 \times$  diameter apart, measured centre to centre.

Position in the neutral axis: between  $0.25$  and  $0.40 \times$  clear span, measured from the support.

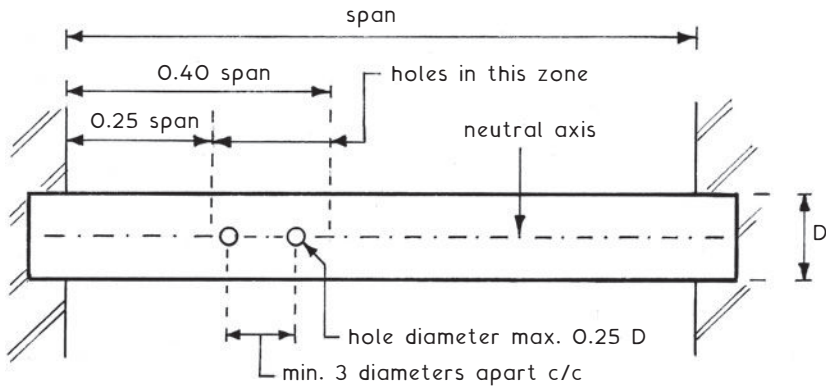

Notching ~ the only practical way of accommodating rigid pipes and conduits in joisted floors.

Depth maximum:  $0.125 \times$  joist depth.

Position between:  $0.07$  and  $0.25 \times$  clear span measured from the support.

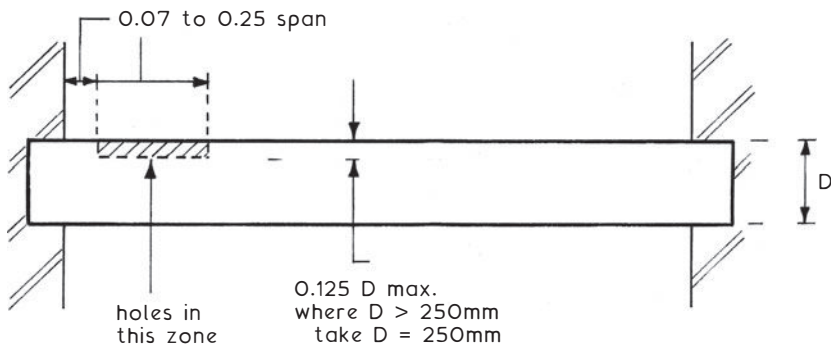

Notching of a joist reduces the effective depth, thereby weakening the joist and reducing its design strength. To allow for this, joists should be oversized.

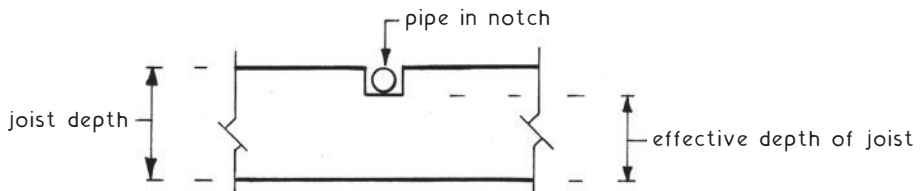

## Timber Upper Floors – Fire Protection (1)

For fire protection, floors are categorised depending on their height relative to adjacent ground ~

Height of top floor above ground	Fire resistance (load bearing)
Less than 5 m	30 minutes
More than 5 m	60 minutes (30 min. for a three-storey dwelling)

Tests for fire resistance relate to load bearing capacity, integrity and insulation as determined by BS 476 – 21: Fire tests on building materials and structures. Methods for determination of the fire resistance of load bearing elements of construction.

Integrity ~ the ability of an element to resist fire penetration.

Insulation ~ ability to resist heat penetration so that fire is not spread by radiation and conduction.

Typical applications ~

### 30-MINUTE FIRE RESISTANCE

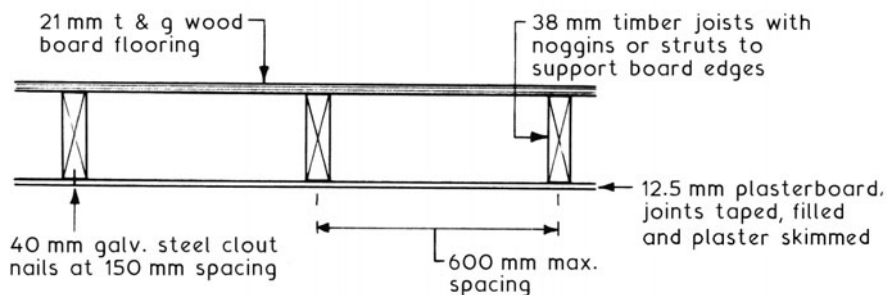

### 60-MINUTE FIRE RESISTANCE

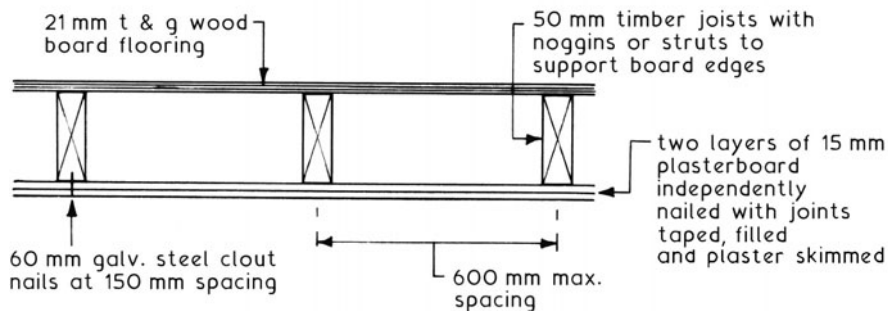

## Timber Upper Floors – Fire Protection (2)

Modified 30-minute fire resistance ~ a lower specification than the full 30-minute fire resistance shown on the preceding page. This is acceptable in certain situations such as some loft conversion floors in existing dwellings and in new-built dwellings of limited height. These situations are defined in Section 4.7 and Appendix A, Table A1 of Approved Document B1 to the Building Regulations.

Load bearing resistance to collapse – 30 minutes minimum.

Integrity – 15 minutes minimum.

Insulation – 15 minutes minimum.

### MODIFIED 30-MINUTE FIRE RESISTANCE

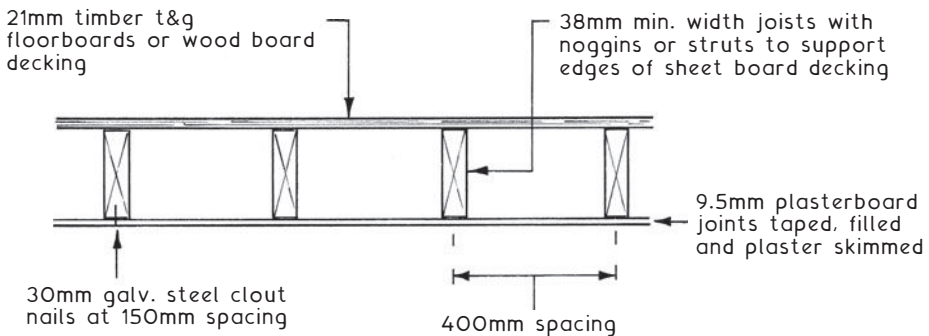

Established floor construction ~ modified 30 minute fire resistant floor construction is often found during refurbishment of housing constructed during the latter part of the 20th century. Here, 9.5 mm plasterboard lath (rounded edge board 1200 mm long x 406 mm wide – now obsolete) was used with floor joists at 400 mm spacing. It is now the general practice to use a 12.5 mm plasterboard ceiling lining to dwelling house floors as this not only provides better fire resistance, but is more stable.

Note 1: Full 30-minute fire resistance must be used for floors over basements or garages.

Note 2: Where a floor provides support or stability to a wall or vice versa, the fire resistance of the supporting element must not be less than the fire resistance of the other element.

Ref. Building Regulations, AD B Fire safety, Volume 1 – Dwelling houses.

## In-situ RC Suspended Floors

Reinforced Concrete Suspended Floors ~ a simple reinforced concrete flat slab cast to act as a suspended floor is not usually economical for spans over 5.000. To overcome this problem beams can be incorporated into the design to span in one or two directions. Such beams usually span between columns which transfers their loads to the foundations. The disadvantages of introducing beams are the greater overall depth of the floor construction and the increased complexity of the formwork and reinforcement. To reduce the overall depth of the floor construction flat slabs can be used where the beam is incorporated with the depth of the slab. This method usually results in a deeper slab with complex reinforcement especially at the column positions.

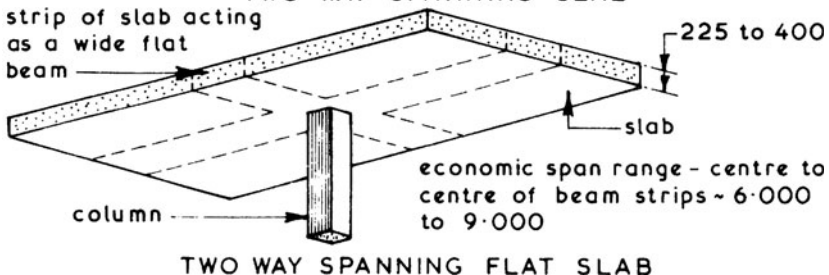
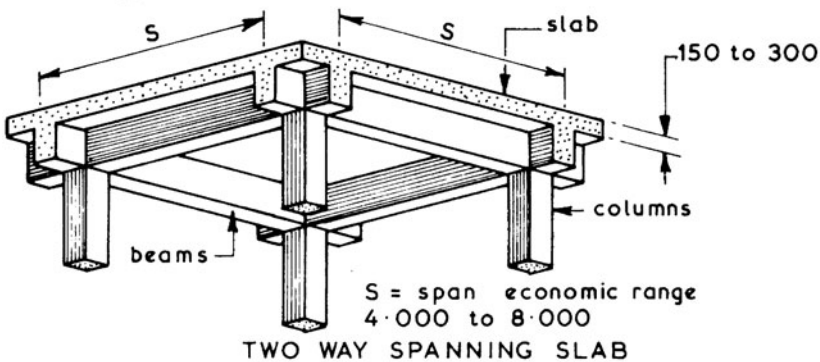
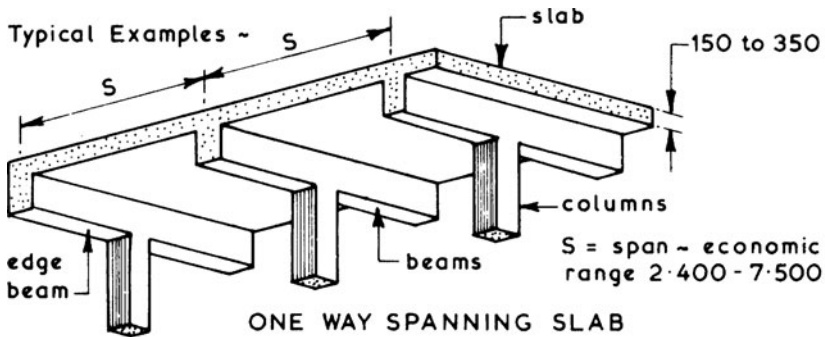

Ribbed Floors ~ to reduce the overall depth of a traditional cast in-situ reinforced concrete beam and slab suspended floor a ribbed floor could be used. The basic concept is to replace the wide spaced deep beams with narrow spaced shallow beams or ribs which will carry only a small amount of slab loading. These floors can be designed as one or two way spanning floors. One way spanning ribbed floors are sometimes called troughed floors whereas the two way spanning ribbed floors are called coffered or waffle floors. Ribbed floors are usually cast against metal, glass-fibre or polypropylene preformed moulds which are temporarily supported on plywood decking, joists and props - see page 594.

Typical Examples ~

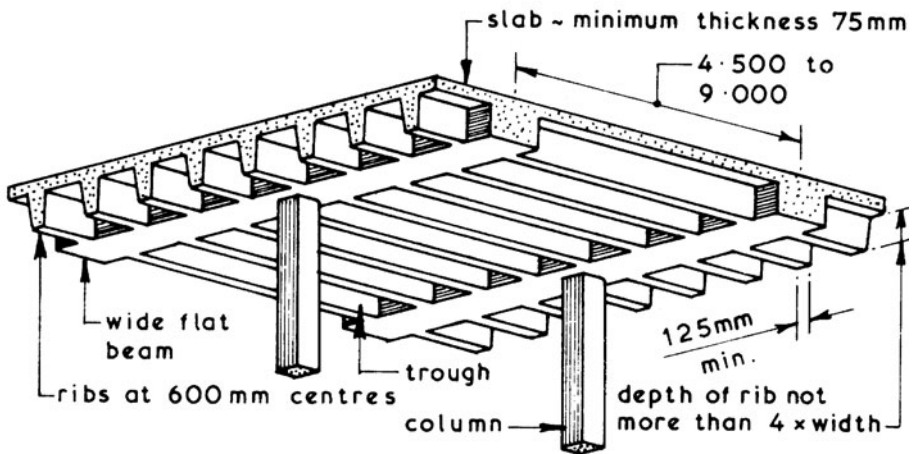

ONE WAY SPANNING RIBBED OR TROUGHED FLOOR

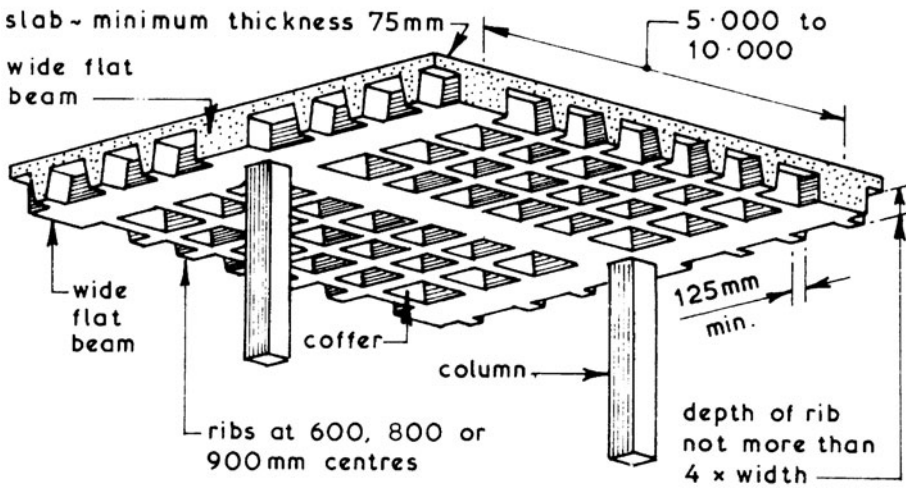

TWO WAY SPANNING COFFERED OR WAFFLE FLOOR

## In-situ RC Suspended Floors

Ribbed Floors – these have greater span and load potential per unit weight than flat slab construction. This benefits a considerable reduction in dead load, to provide cost economies in other super-structural elements and foundations. The regular pattern of voids created with waffle moulds produces a honeycombed effect, which may be left exposed in utility buildings such as car parks. Elsewhere, such as shopping malls, a suspended ceiling would be appropriate. The trough finish is also suitable in various situations and has the advantage of creating a continuous void for accommodation of service cables and pipes. A suspended ceiling can add to this space where air conditioning ducting is required, also providing several options for finishing effect.

Typical mould profile –

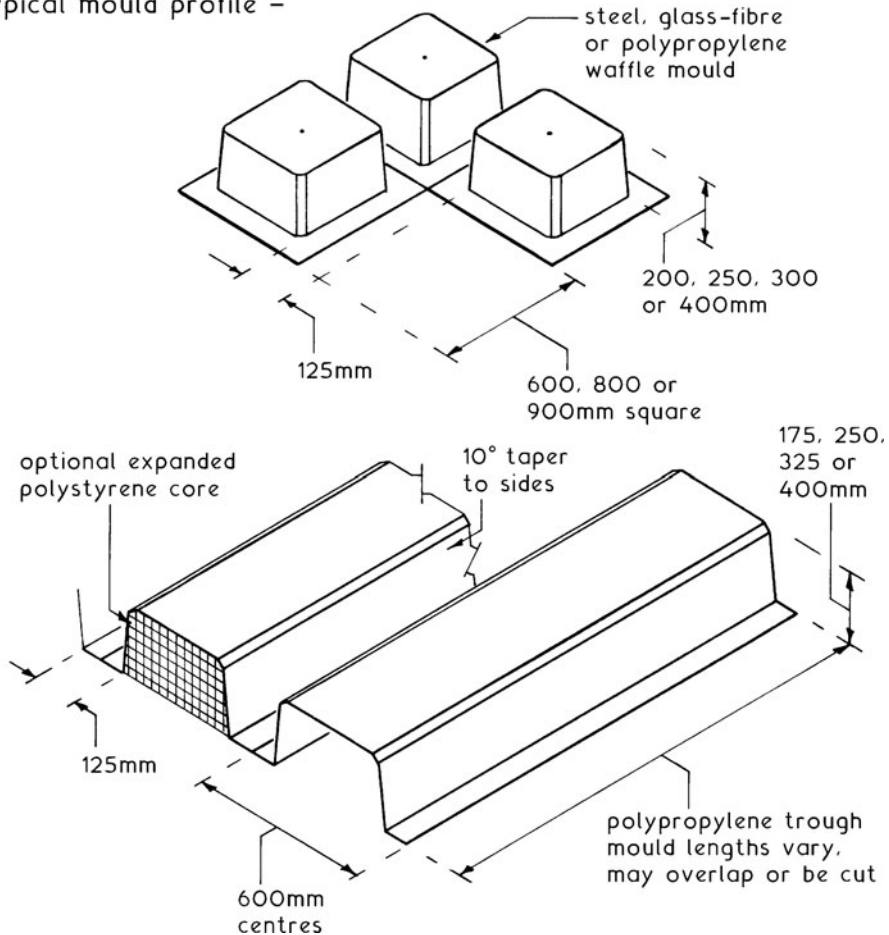

NB. After removing the temporary support structure, moulds are struck by flexing with a flat tool. A compressed air line is also effective.

Hollow Pot Floors ~ these are in essence a ribbed floor with permanent formwork in the form of hollow clay or concrete pots. The main advantage of this type of cast in-situ floor is that it has a flat soffit which is suitable for the direct application of a plaster finish or an attached dry lining. The voids in the pots can be utilised to house small diameter services within the overall depth of the slab. These floors can be designed as one or two way spanning slabs, the common format being the one way spanning floor.

Typical Example ~

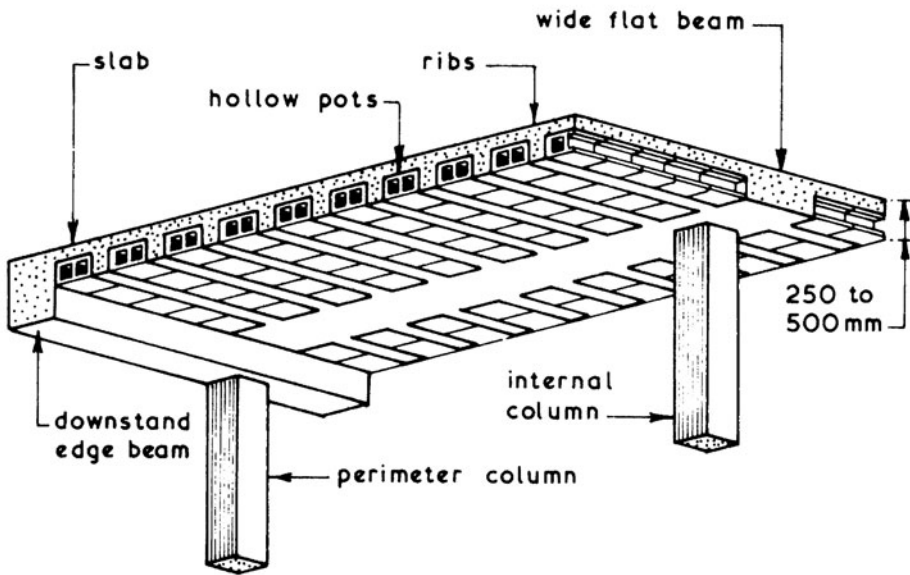

ONE WAY SPANNING HOLLOW POT FLOOR

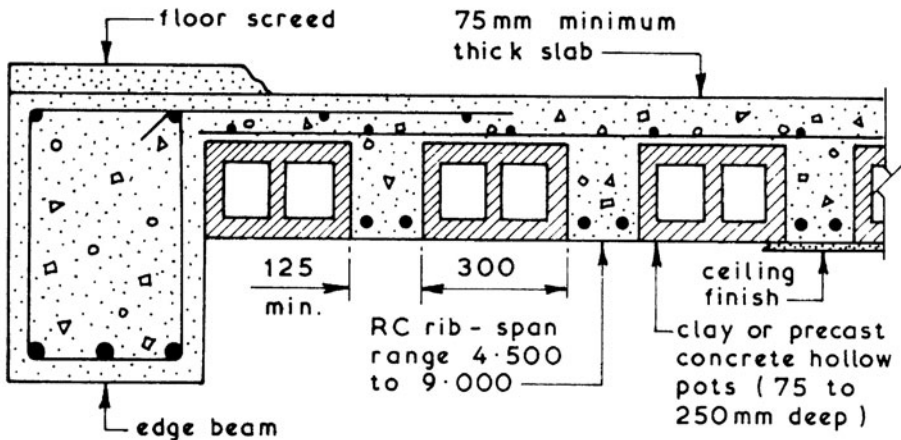

TYPICAL SECTION



## In-situ RC Suspended Floors

Soffit and Beam Fixings ~ concrete suspended floors can be designed to carry loads other than the direct upper surface loadings. Services can be housed within the voids created by the beams or ribs and suspended or attached ceilings can be supported by the floor. Services which run at right angles to the beams or ribs are usually housed in cast-in holes. There are many types of fixings available for use in conjunction with floor slabs. Some are designed to be cast-in whilst others are fitted after the concrete has cured. All fixings must be positioned and installed so that they are not detrimental to the structural integrity of the floor.

Typical Examples ~

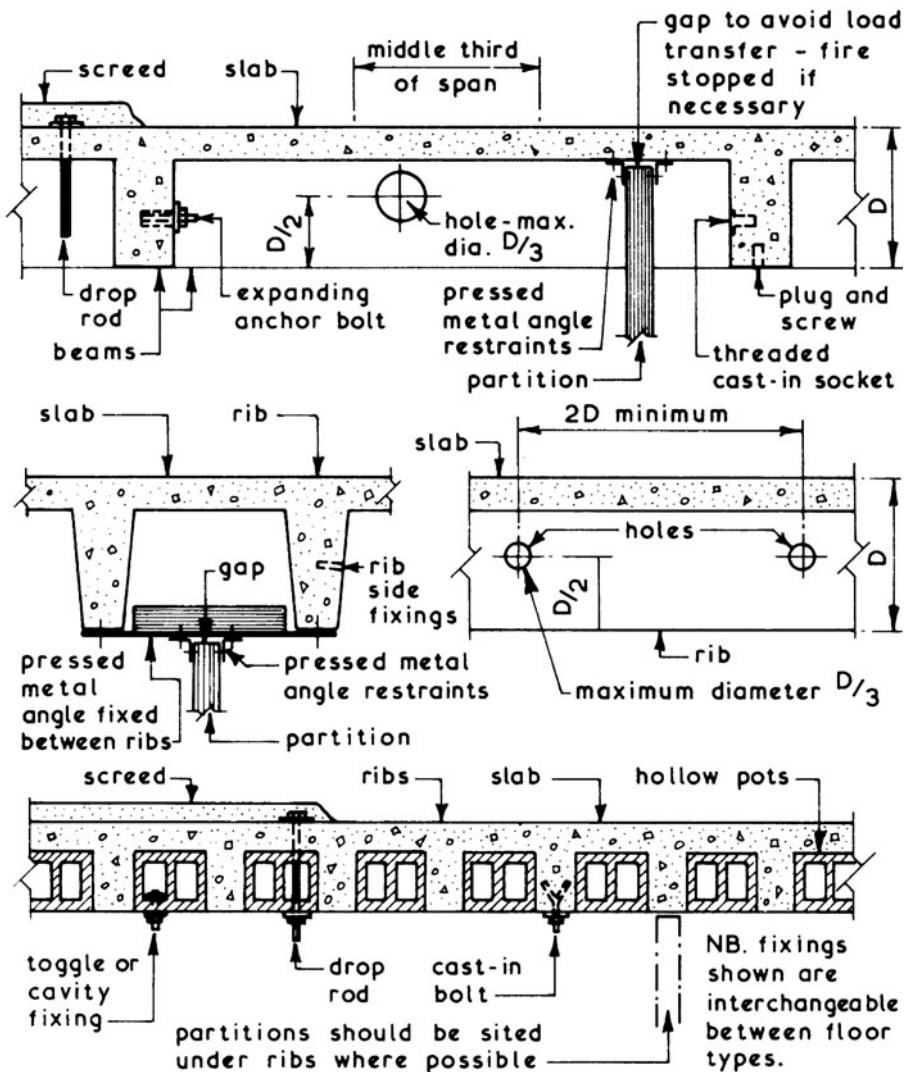

Precast Concrete Floors ~ these are available in several basic formats and provide an alternative form of floor construction to suspended timber floors and in-situ reinforced concrete suspended floors. The main advantages of precast concrete floors are:

1. Elimination of the need for formwork except for nominal propping which is required with some systems.
2. Curing time of concrete is eliminated, therefore the floor is available for use as a working platform at an earlier stage.
3. Superior quality control of product is possible with factory-produced components.

The main disadvantages of precast concrete floors when compared with in-situ reinforced concrete floors are:

1. Less flexible in design terms.
2. Formation of large openings in the floor for ducts, shafts and stairwells usually have to be formed by casting an in-situ reinforced concrete floor strip around the opening position.
3. Higher degree of site accuracy is required to ensure that the precast concrete floor units can be accommodated without any alterations or making good.

Typical Basic Formats ~

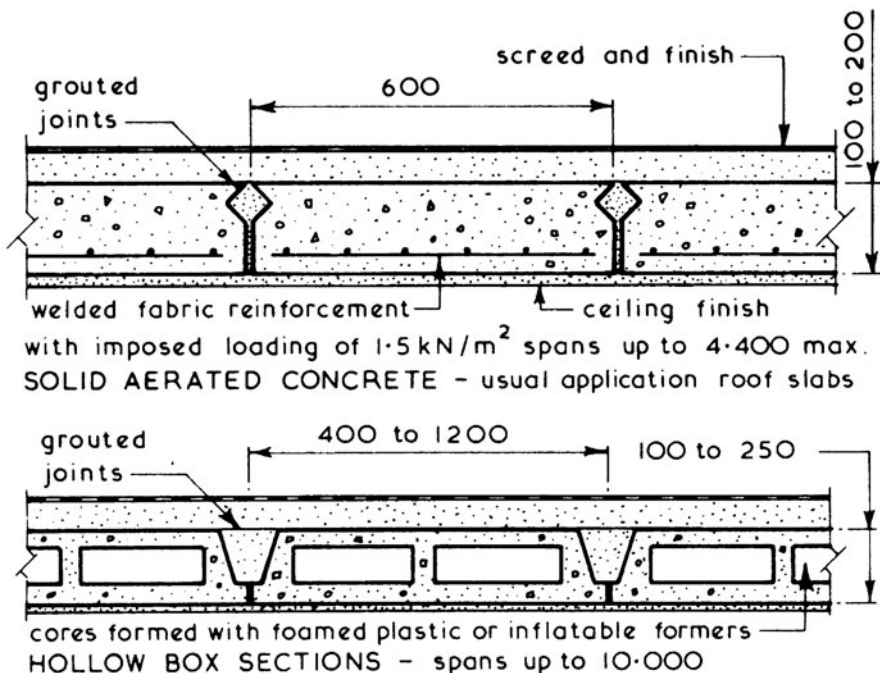

# Precast Concrete Floors

Typical Basic Formats ~

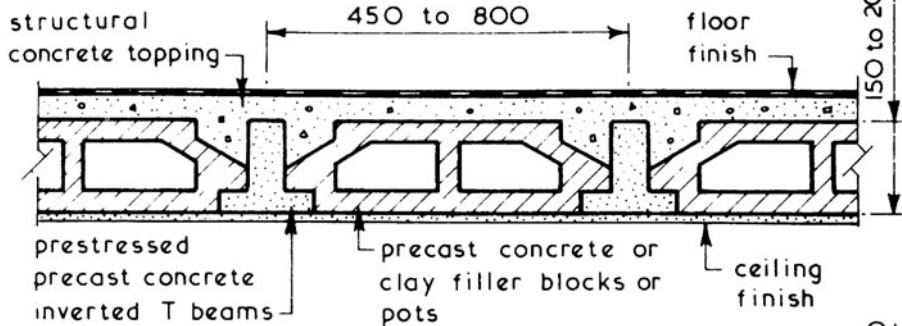

PCC BEAM AND POT COMPOSITE FLOOR - max span 7.500

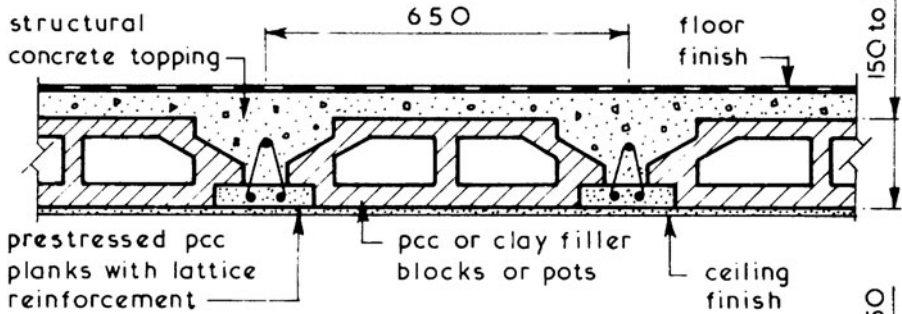

PCC PLANK AND POT COMPOSITE FLOOR - max span 12.000

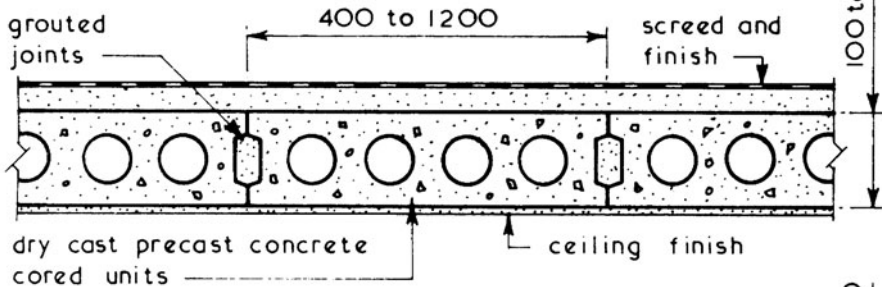

PCC CORED UNITS - max. span 10.000

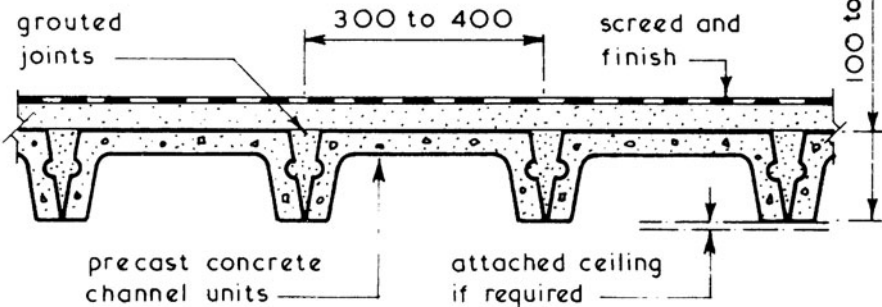

PCC CHANNEL UNITS - max. span 6.750

Bearing Considerations ~

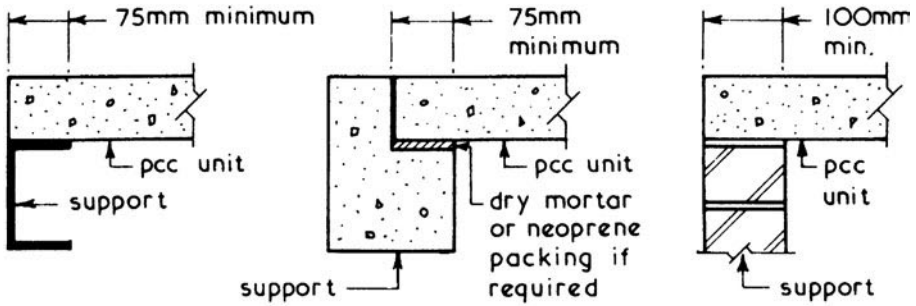

STEEL SUPPORT      CONCRETE SUPPORT      MASONRY SUPPORT

NB. spalling to end of pcc unit and/or edge of support will reduce effective bearing length.

Lateral Restraint and Structural Continuity Considerations ~

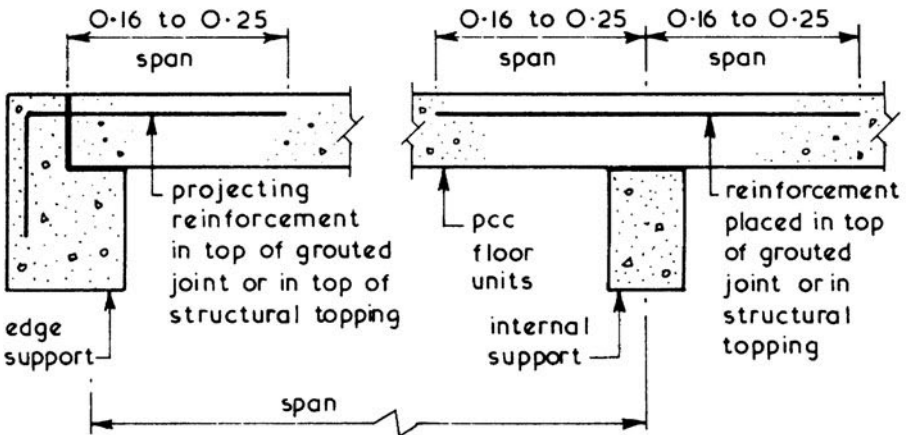

Opening Considerations ~

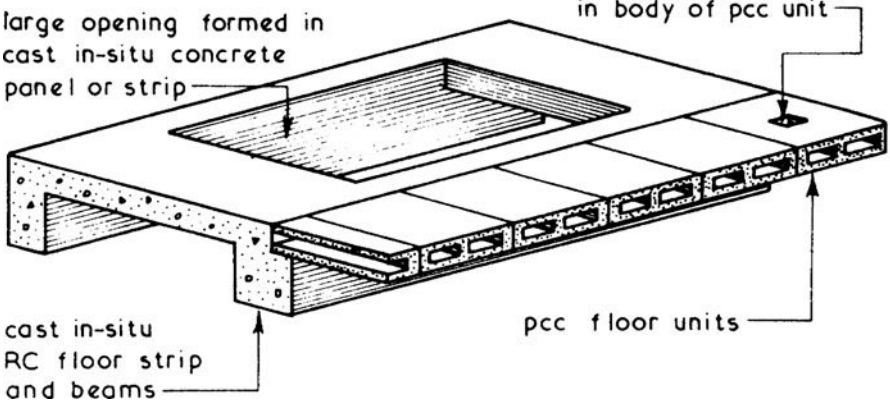

## Precast Concrete Floors – Fabricated Beam

Steel fabricated beams can be used as an integral means of support for precast concrete floors. These are an overall depth and space-saving alternative compared to down-stand reinforced concrete beams or masonry walls. Only the lower steel flange of the steel beam is exposed.

To attain sufficient strength, a supplementary steel plate is welded to the bottom flange of standard UC sections. This produces a type of compound or plated section that is supported by the main structural frame.

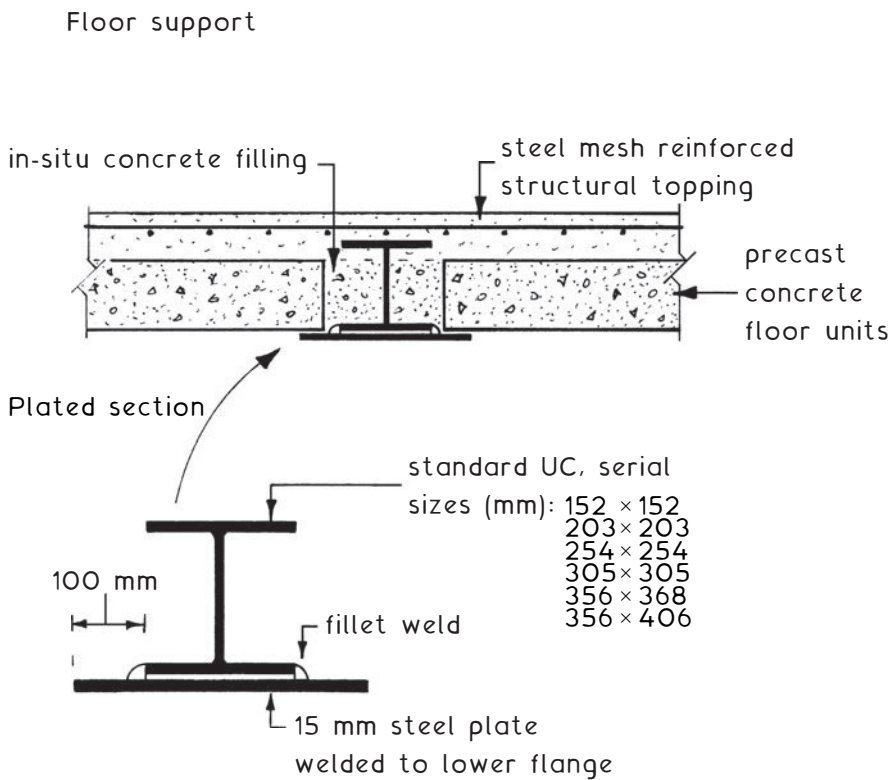

Note: For fillet weld details and other welding applications, see page 636.

## Precast Concrete Floors – Asymmetric Beam

A standard manufactured steel beam with similar applications to the plated UC shown on the previous page. This purpose-made alternative is used with lightweight flooring units, such as precast concrete hollow core slabs and metal section decking of the type shown on page 595.

Standard production serial size range ~

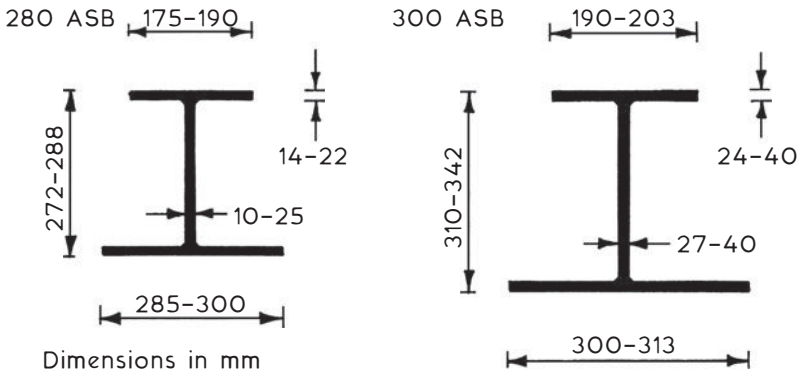

Application ~

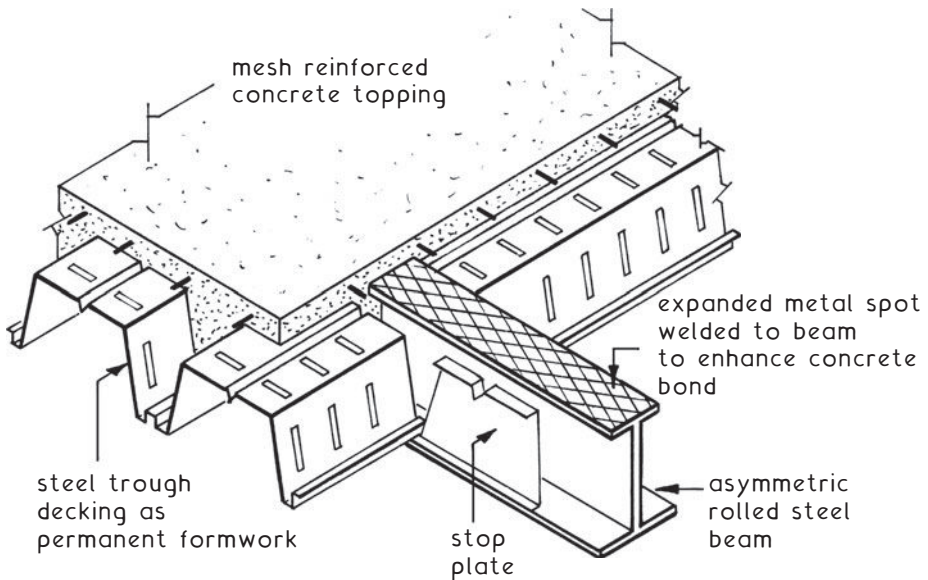

# Raised Access Floors

Raised Flooring ~ developed in response to the high-tech boom of the 1970s. It has proved expedient in accommodating computer and communications cabling as well as numerous other established services. The system is a combination of adjustable floor pedestals, supporting a variety of decking materials. Pedestal height ranges from as little as 30 mm up to about 600 mm, although greater heights are possible at the expense of structural floor levels. Decking is usually in loose fit squares of 600 mm, but may be sheet plywood or particleboard screwed direct to closer spaced pedestal support plates on to joists bearing on pedestals.

Cavity fire stops are required between decking and structural floor at appropriate intervals (see Building Regulations, A D B, Volume 2, Section 9).

Application ~

## PEDESTAL DETAIL

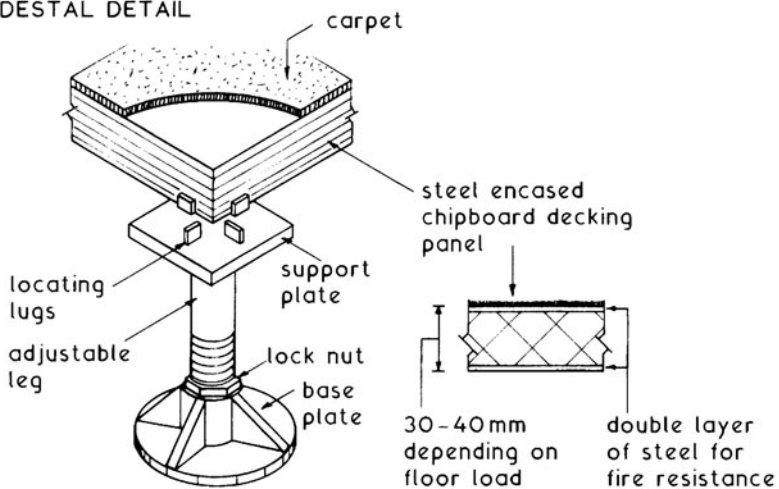

## FLOOR SECTION

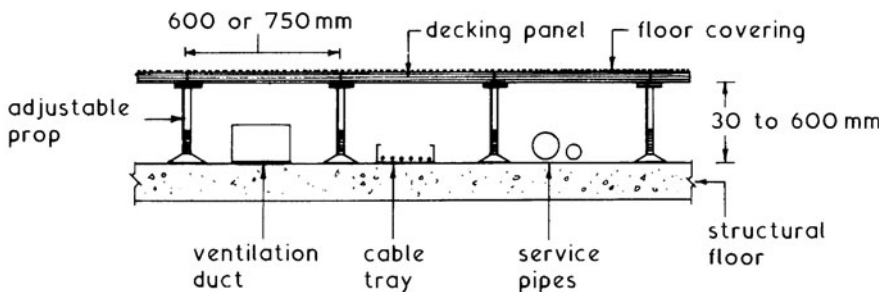

Sound Insulation ~ sound can be defined as vibrations of air which are registered by the human ear. All sounds are produced by a vibrating object which causes tiny particles of air around it to move in unison. These displaced air particles collide with adjacent air particles setting them in motion and in unison with the vibrating object. This continuous chain reaction creates a sound-wave which travels through the air until at some distance the air particle movement is so small that it is inaudible to the human ear. Sounds are defined as either impact or airborne sound, the definition being determined by the source producing the sound. Impact sounds are created when the fabric of structure is vibrated by direct contact whereas airborne sound only sets the structural fabric vibrating in unison when the emitted sound-wave reaches the enclosing structural fabric. The vibrations set up by the structural fabric can therefore transmit the sound to adjacent rooms which can cause annoyance, disturbance of sleep and of the ability to hold a normal conversation. The objective of sound insulation is to reduce transmitted sound to an acceptable level, the intensity of which is measured in units of decibels (dB).

The Building Regulations, Approved Document E: Resistance to the passage of sound, establishes sound insulation standards as follows:

E1: Between dwellings and between dwellings and other buildings.

E2: Within a dwelling, i.e. between rooms, particularly WCs and habitable rooms, and bedrooms and other rooms.

E3: Control of reverberation noise in common parts (stairwells and corridors) of buildings containing dwellings, i.e. flats.

E4: Specific applications to acoustic conditions in schools.

Note: E1 includes hotels, hostels, student accommodation, nurses' homes and homes for the elderly, but not hospitals and prisons.

## Typical Sources and Transmission of Sound ~

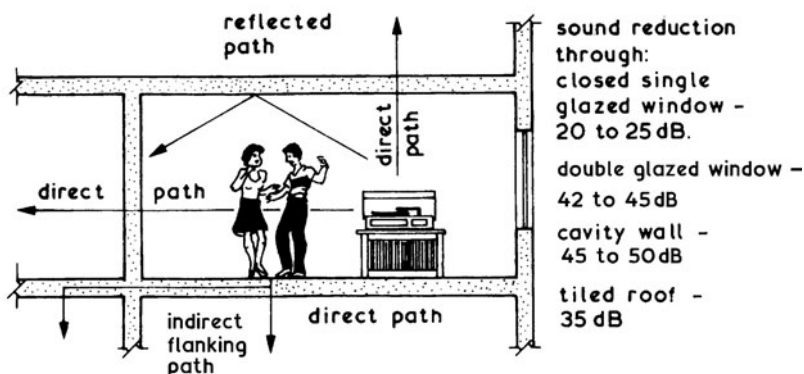



## Sound Insulation – Internal Walls and Floors (Dwellings)

The Approved Document to Building Regulation E2 provides for internal walls and floors located between a bedroom or a room containing a WC and other rooms to have a reasonable resistance to airborne sound. Impact sound can be improved by provision of a carpet.

Typical Details ~

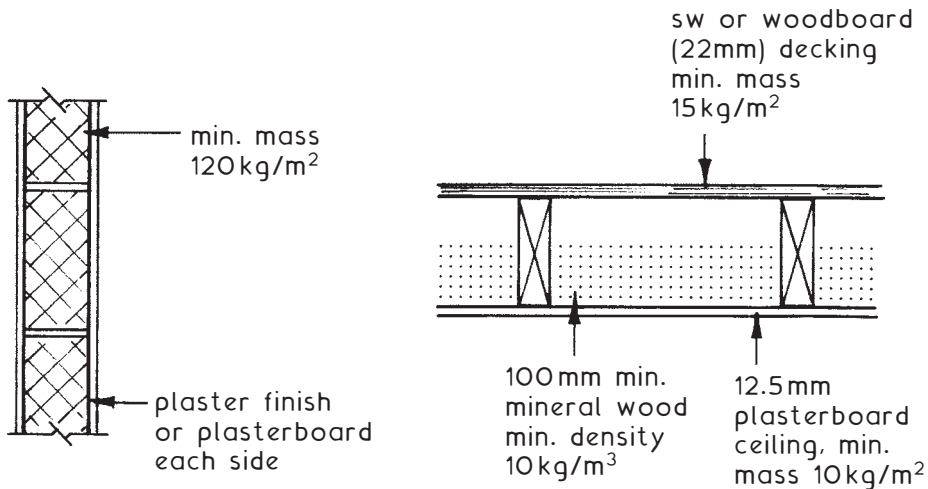
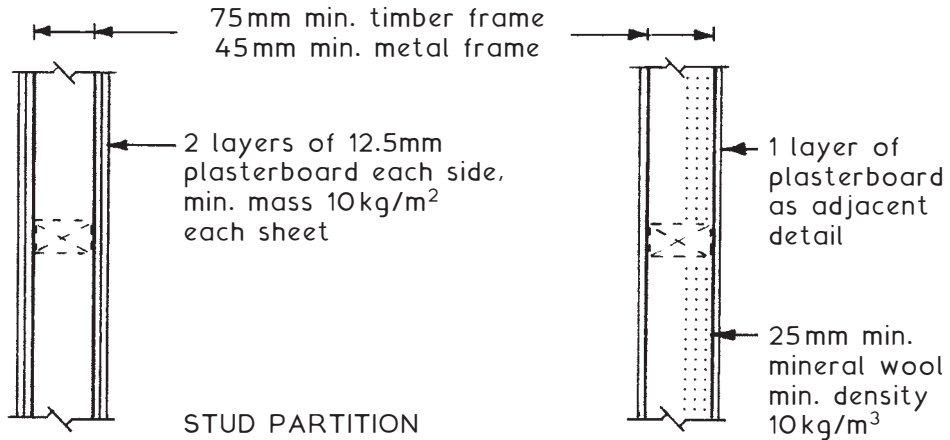

CONCRETE  
BLOCKWORK PARTITION

TRADITIONAL SUSPENDED  
TIMBER FLOOR

SUSPENDED CONCRETE FLOORS (See page 790)

Cored plank ~ min. mass 180 kg/m<sup>2</sup> with any top surface and ceiling finish.

Precast beam and filler block (pot) ~ min. mass 220 kg/m<sup>2</sup> with 40mm bonded screed and 12.5mm plasterboard ceiling on battens.

Separating Walls ~ types:

1. Solid masonry
2. Cavity masonry
3. Masonry between isolating panels
4. Timber frame

Type 1 – relies on mass

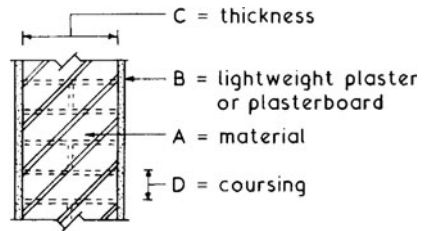

Material A	Density of A [kg/m <sup>3</sup> ]	Finish B	Combined mass A + B (kg/m <sup>2</sup> )	Thickness C [mm]	Coursing D [mm]
Brickwork	1610	13 mm lwt. pl.	375	215	75
...	...	12.5 mm pl. brd.	...	...	...
Concrete block	1840	13 mm lwt. pl.	415	...	110
...	1840	12.5 mm pl. brd.	...	...	150
In-situ concrete	2200	Optional	415	190	n/a

Type 2 – relies on mass and isolation

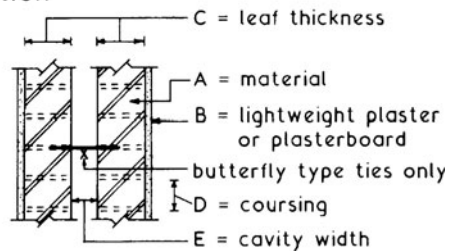

Material A	Density of A [kg/m <sup>3</sup> ]	Finish B	Mass A + B (kg/m <sup>2</sup> )	Thickness C [mm]	Coursing D [mm]	Cavity E [mm]
Bkwk.	1970	13 mm lwt. pl.	415	102	75	50
Concrete block	1990	..	..	100	225	..
Lwt. conc. block	1375	.. or 12.5 mm pl. brd.	300	100	225	75

## Sound Insulation – Walls

- Type 3 ~ relies on: (a) core material type and mass.  
 (b) isolation, and  
 (c) mass of isolated panels.

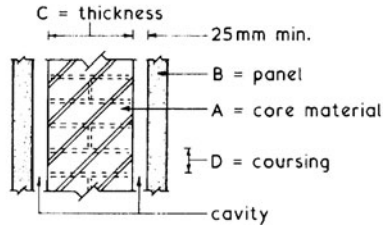

Core material A	Density of A [kg/m <sup>3</sup> ]	Mass A (kg/m <sup>2</sup> )	Thickness C (mm)	Coursing D (mm)	Cavity (mm)
Brickwork	1290	300	215	75	n/a
Concrete block	2200	300	140	110	n/a
Lwt. conc. block	1400	150	200	225	n/a
Cavity bkwk. or block	any	any	2 × 100	to suit	50

### Panel materials – B:

- (a) Plasterboard with cellular core plus plaster finish, mass 18 kg/m<sup>2</sup>. All joints taped. Fixed floor and ceiling only.  
 (b) 2 No. plasterboard sheets, 12.5 mm each, with joints staggered. Frame support or 30 mm overall thickness.

### Type 4 – relies on mass, frame separation and absorption of sound.

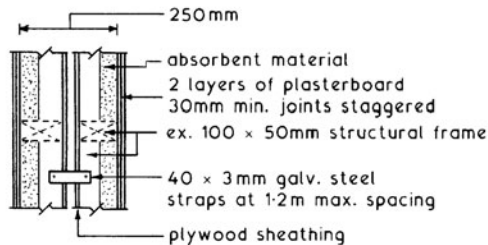

Absorbent material – quilting of unfaced mineral fibre batts with a minimum density of 10 kg/m<sup>3</sup>, located in the cavity or frames.

Thickness (mm)	Location
25	Suspended in cavity
50	Fixed within one frame
2 × 25	Each quilt fixed within each frame

Separating Floors ~ types:

1. Concrete with soft covering
2. Concrete with floating layer
3. Timber with floating layer (see next page)

Type 1. Airborne resistance depends on mass of concrete and ceiling.  
Impact resistance depends on softness of covering.

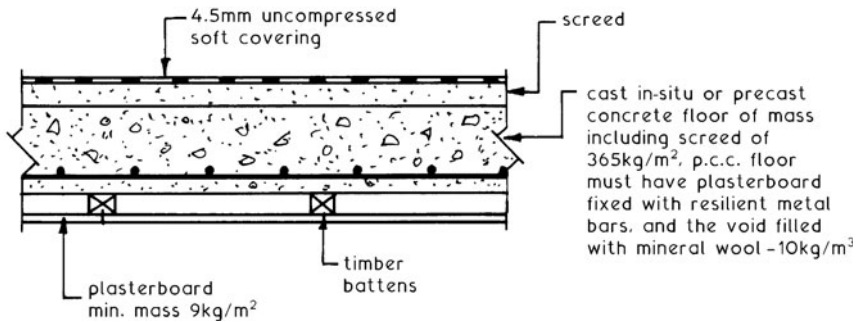

Type 2. Airborne resistance depends mainly on concrete mass and partly on mass of floating layer and ceiling.  
Impact resistance depends on resilient layer isolating floating layer from base and isolation of ceiling.

Bases: As type 1. but overall mass minimum  $300\text{ kg/m}^2$ .

Floating layers:

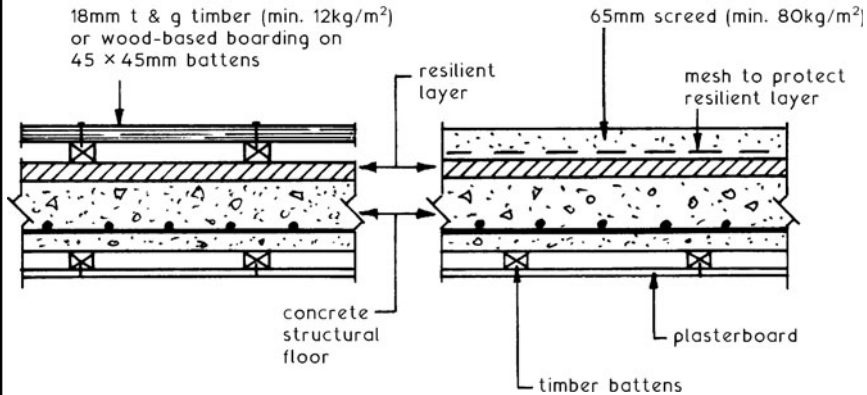

Resilient layers:

- (a) 25 mm paper faced mineral fibre, density  $36\text{kg/m}^3$ .  
Timber floor – paper faced underside.  
Screeded floor – paper faced upper side to prevent screed from entering layer.
- (b) Screeded floor only:  
13 mm pre-compressed expanded polystyrene (EPS) board, or 5 mm extruded polyethylene foam of density  $30\text{--}45\text{ kg/m}^3$ , laid over a levelling screed for protection.

Ref. See BS EN 29052-1: Acoustics. Method for the determination of dynamic stiffness. Materials used under floating floors in dwellings.

## Sound Insulation – Floors

Type 3. Airborne resistance varies depending on floor construction, absorbency of materials, extent of pugging and partly on the floating layer. Impact resistance depends mainly on the resilient layer separating floating from structure.

### Platform Floor ~

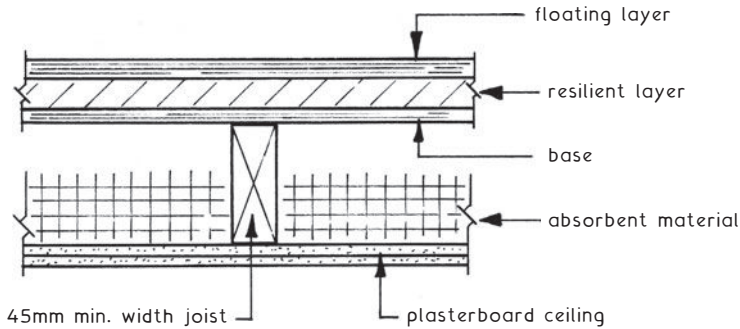

NB. Minimum mass per unit area =  $25\text{kg/m}^2$ .

Floating layer: 18 mm timber or wood-based board, t & g joints glued and spot bonded to a sub-strate of 19 mm plasterboard. Alternative sub-strate of cement bonded particle board in two 12 mm thicknesses, joints staggered, glued and screwed together.

Resilient layer: 25 mm mineral fibre, density  $60\text{--}100\text{ kg/m}^3$ .

Base: 12 mm timber boarding or wood-based board nailed to joists.

Absorbent material: 100 mm mineral fibre of minimum density  $10\text{ kg/m}^3$ .

Ceiling: 30 mm plasterboard in two layers, joints staggered.

### Ribbed or battened floor ~

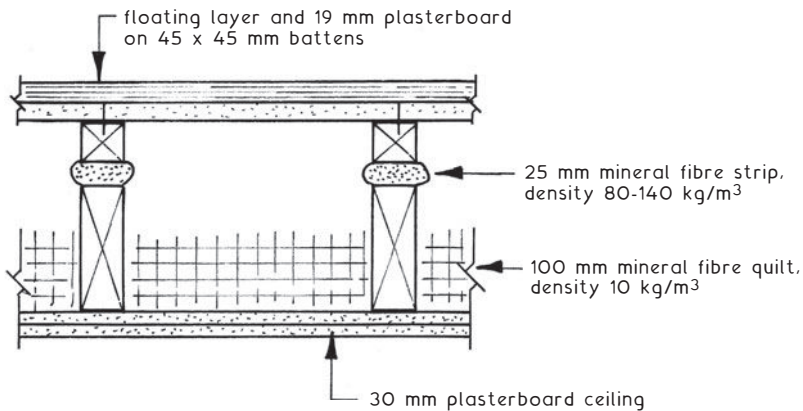

NB. See next page for other examples of ribbed floors.

Type 3 (continued).

Alternative ribbed or battened floor ~

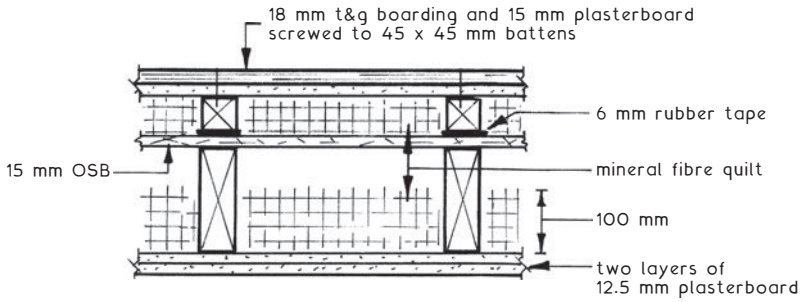

Ribbed or battened floor with dry sand pugging ~

Example 1

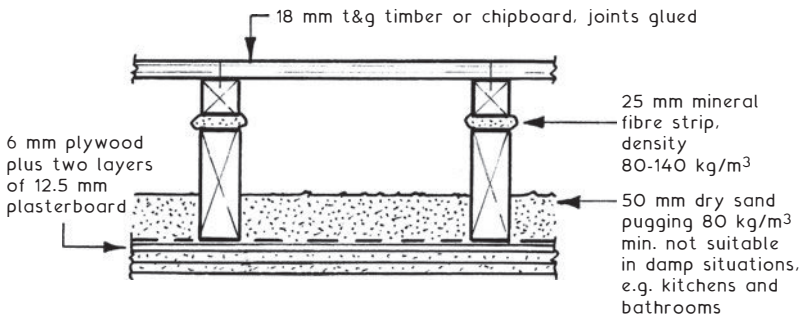

Example 2

Alternative to Example 1

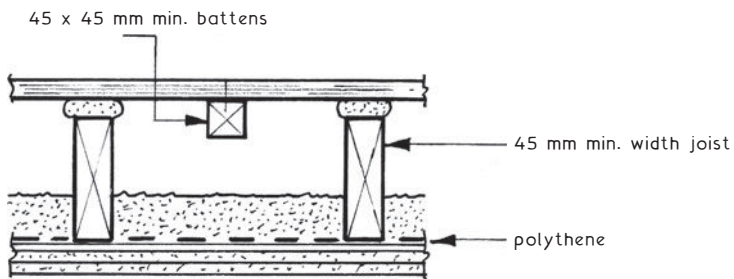

NB. Plasterboard in two layers, joints staggered.

OSB = Oriented strand board.

## Sound Insulation – Improving Existing Construction

The intensity of unwanted sound that increases vibration of a separating wall or floor can be reduced to some extent by attaching a lining to the existing structure. Plasterboard or other dense material is suitable, but this will have only a limited effect as the lining will also vibrate and radiate sound. The most effective solution is to create another wall or ceiling next to the original, but separated from it.

### Separating wall ~

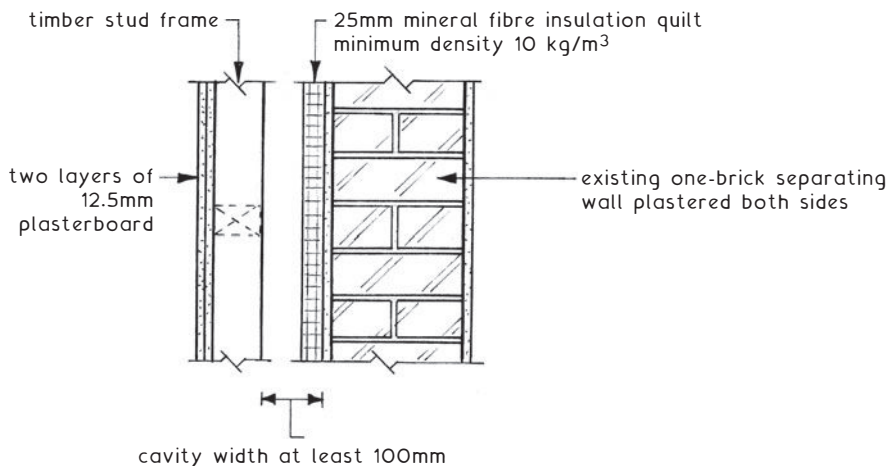

### Separating floor ~

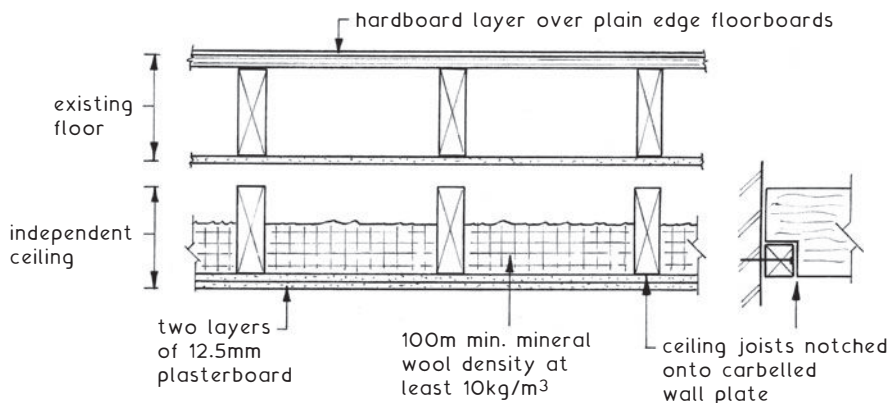

Refs.: BS 8233: Sound insulation and noise reduction for buildings. Code of practice.  
BRE Digest 293: Improving the sound insulation of separating walls and floors.

Primary Functions ~

- 1. Provide a means of circulation between floor levels.
- 2. Establish a safe means of travel between floor levels.
- 3. Provide an easy means of travel between floor levels.
- 4. Provide a means of conveying fittings and furniture between floor levels.

Constituent Parts ~

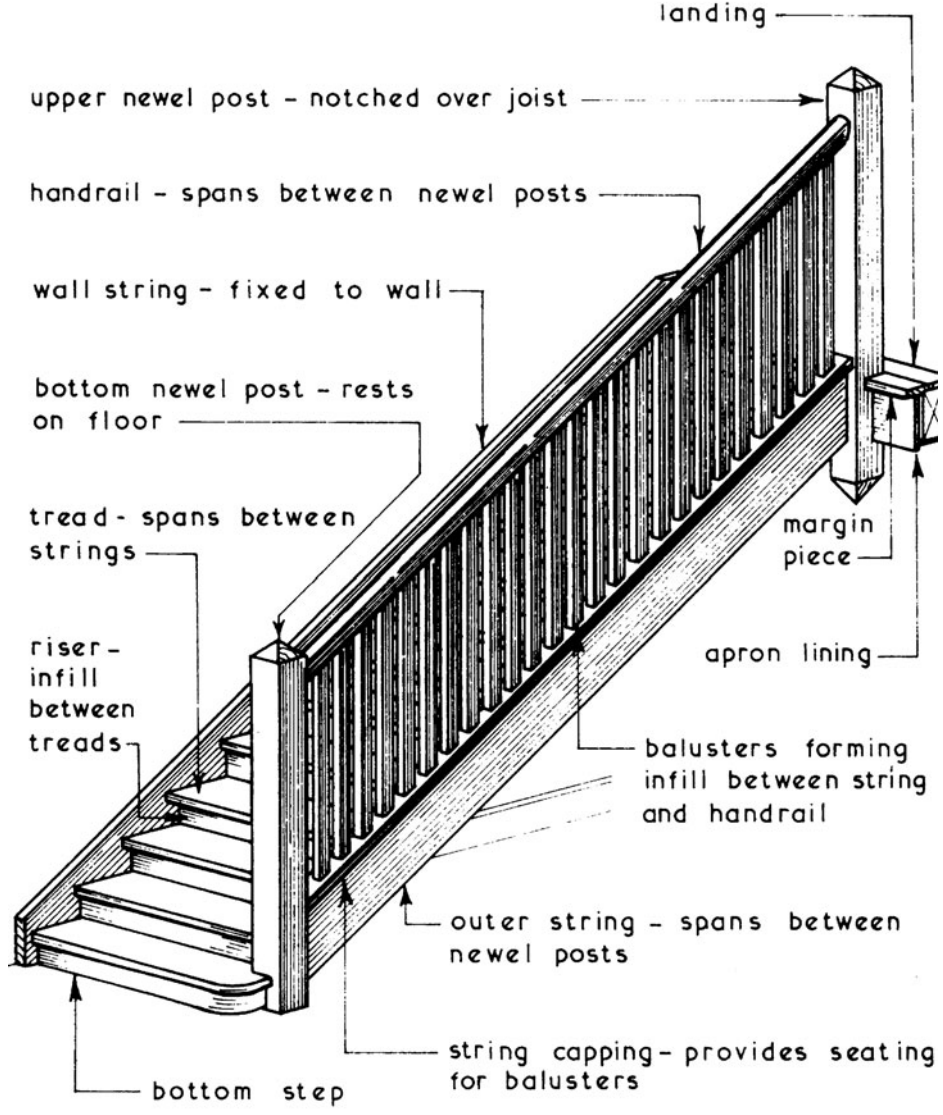

STRAIGHT FLIGHT STAIRS



# Domestic Straight Flight Stairs – Critical Dimensions

All dimensions quoted are the minimum required for domestic stairs exclusive to one dwelling as given in Approved Document K unless stated otherwise.

## Terminology ~

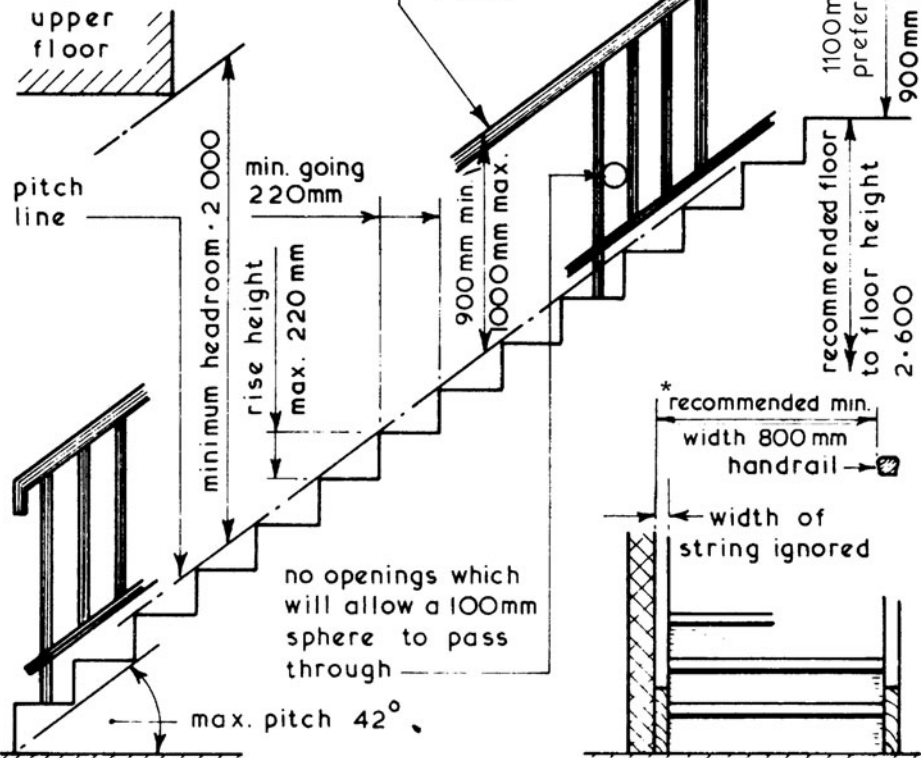
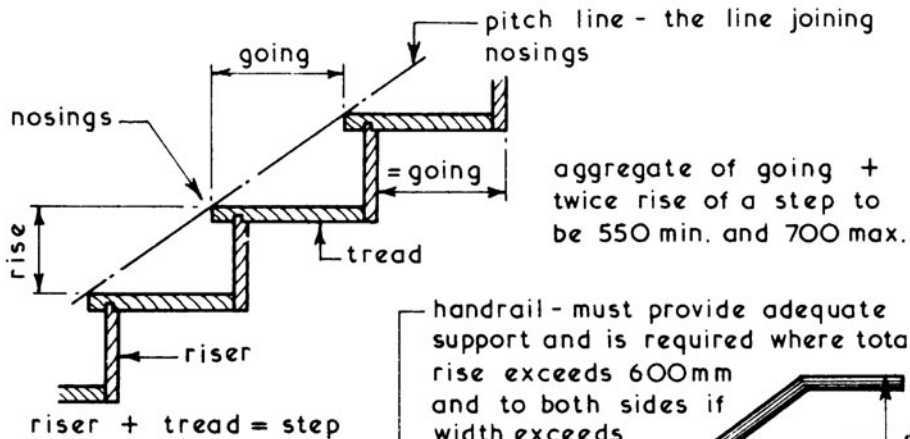

\*A.D. K does not give a minimum dimension for stair width. See also page 808.

Step Formats ~

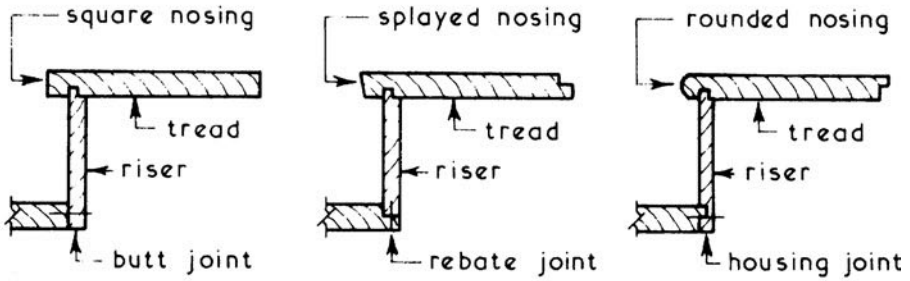

NB. nosing types and joints are interchangeable between step formats.

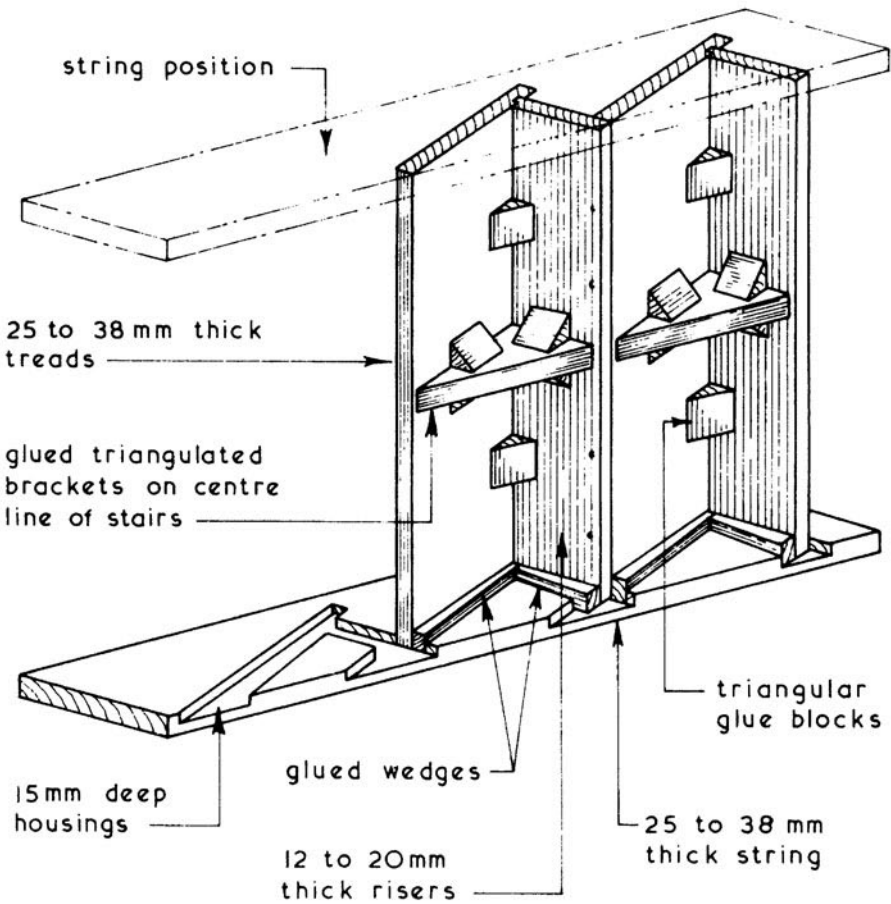

STAIR FLIGHT CONSTRUCTION

# Straight Flight Timber Stair Details

## Bottom Step Arrangements ~

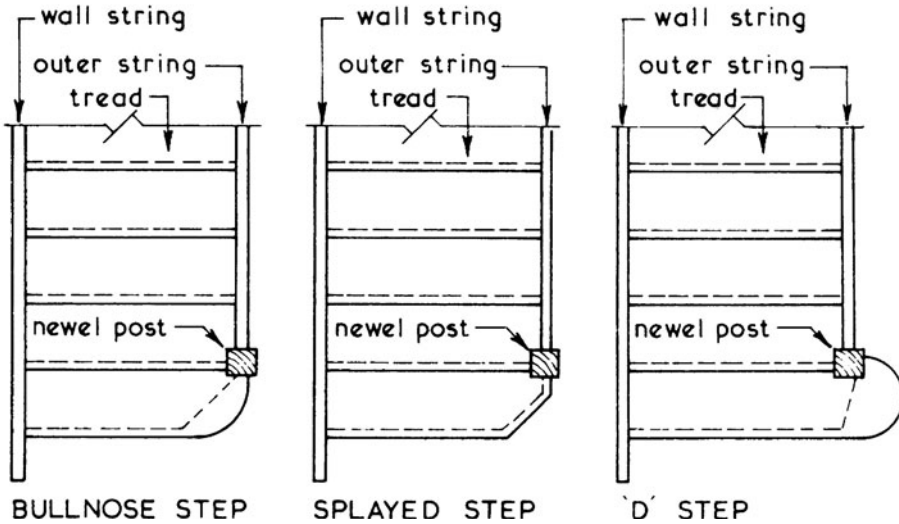

Projecting bottom steps are usually included to enable the outer string to be securely jointed to the back face of the newel post and to provide an easy line of travel when ascending or descending at the foot of the stairs.

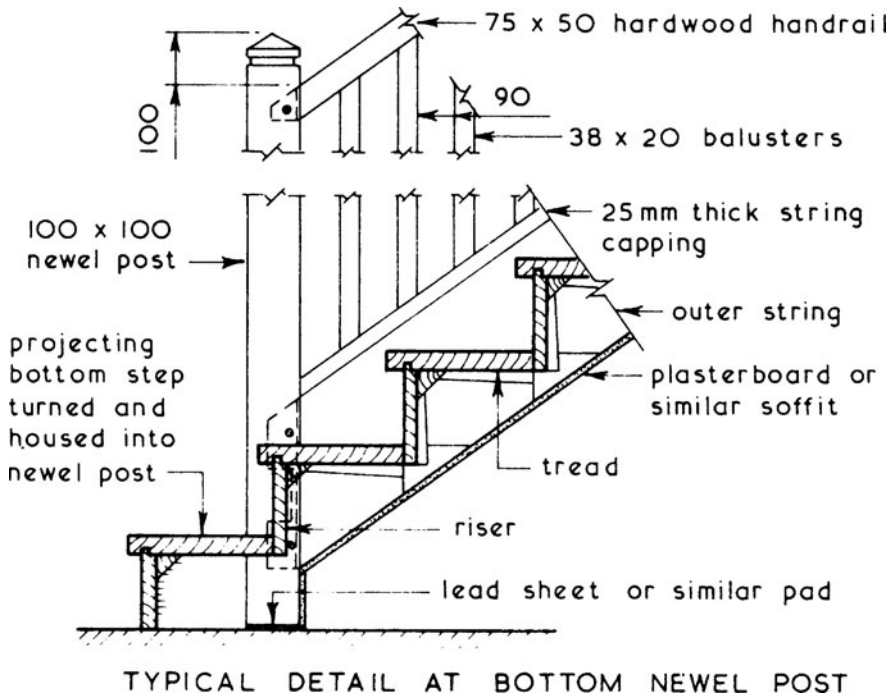

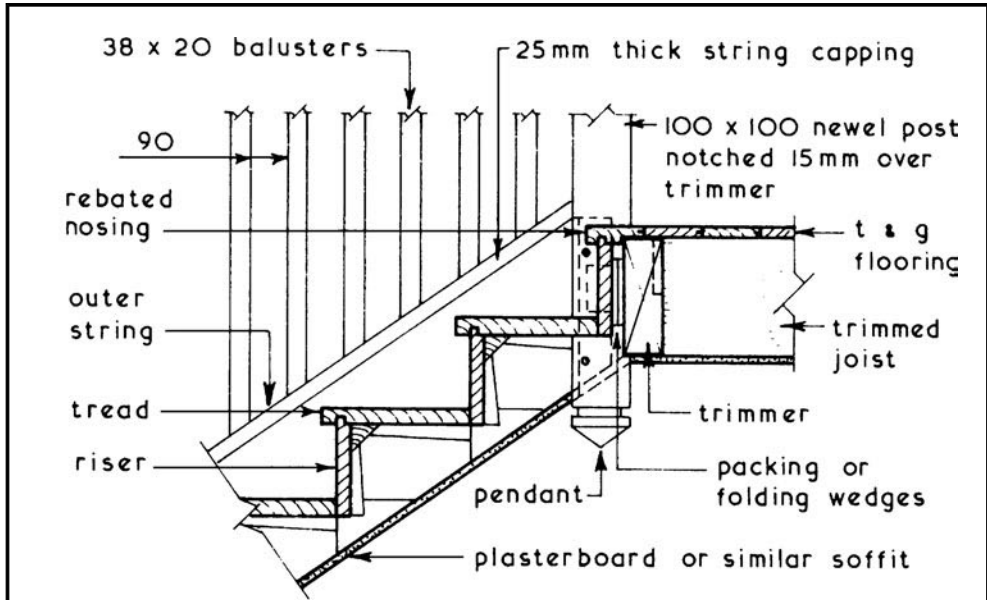

TYPICAL DETAIL AT TOP NEWEL POST

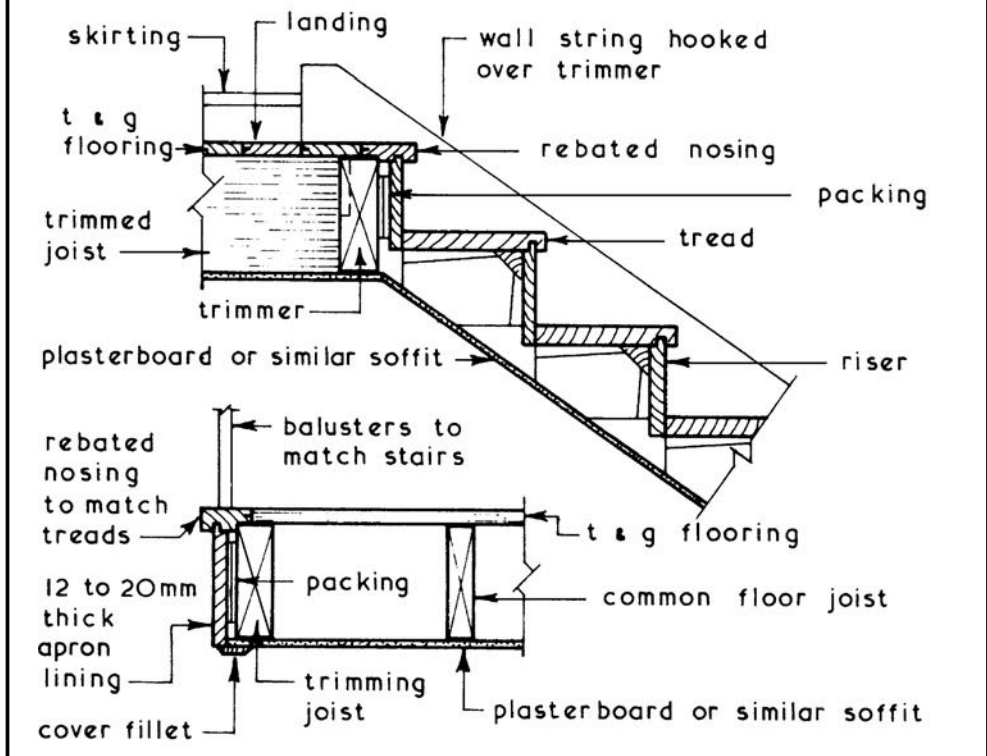

TYPICAL DETAILS AT LANDING AND STAIRWELL

# Timber Open Riser Stairs

Timber Open Riser Stairs ~ these are timber stairs constructed to the same basic principles as standard timber stairs excluding the use of a riser. They have no real advantage over traditional stairs except for the generally accepted aesthetic appeal of elegance. Like the traditional timber stairs they must comply with the minimum requirements set out in Part K of the Building Regulations.

Typical Requirements for Stairs in a Small Residential Building ~

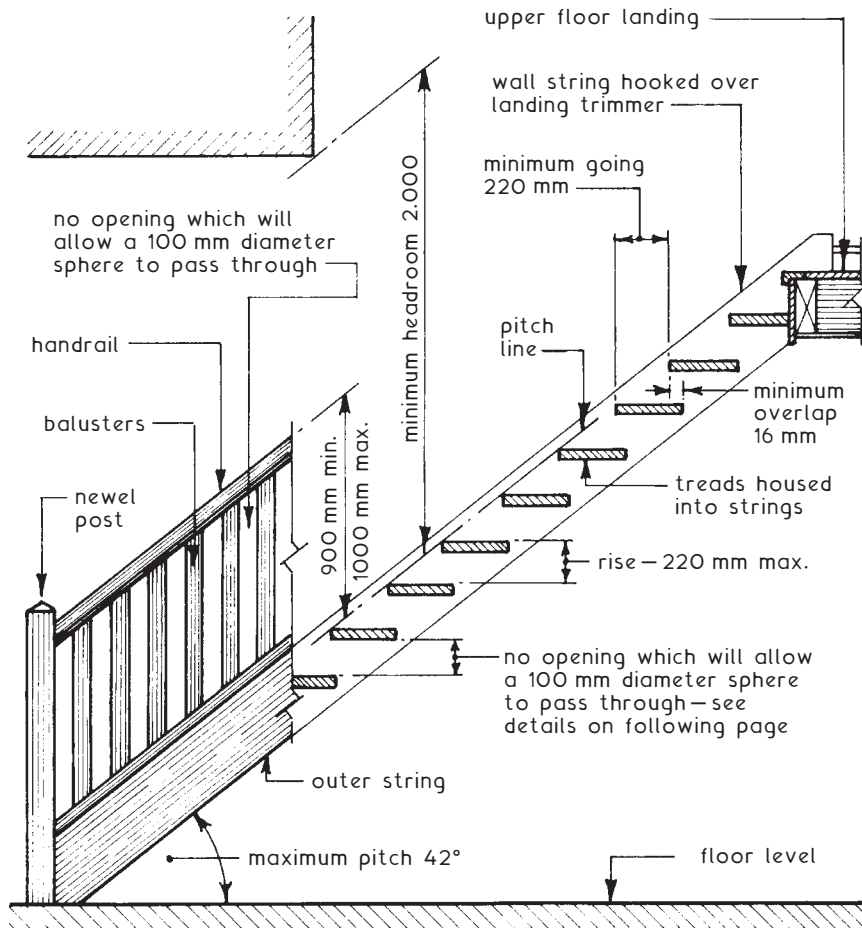

Recommended clear width for all stairs is 800mm minimum, but 900 mm wall to wall or wall to centre of handrail is preferable. Clear width is defined in BS 585-1 as 'unobstructed width between handrail and face of newel', but see also page 804. A reduced clear width of 600mm is acceptable for access to limited use space such as a loft.

Aggregate of going plus twice the rise to be 550 mm minimum and 700mm maximum

Design and Construction ~ because of the legal requirement of not having a gap between any two consecutive treads through which a 100 mm diameter sphere can pass and the limitation relating to the going and rise, as shown on the previous page, it is generally not practicable to have a completely riserless stair for residential buildings since by using minimum dimensions a very low pitch of approximately  $27\frac{1}{2}^\circ$  would result and by choosing an acceptable pitch a very thick tread would have to be used to restrict the gap to 100 mm.

Possible Solutions ~

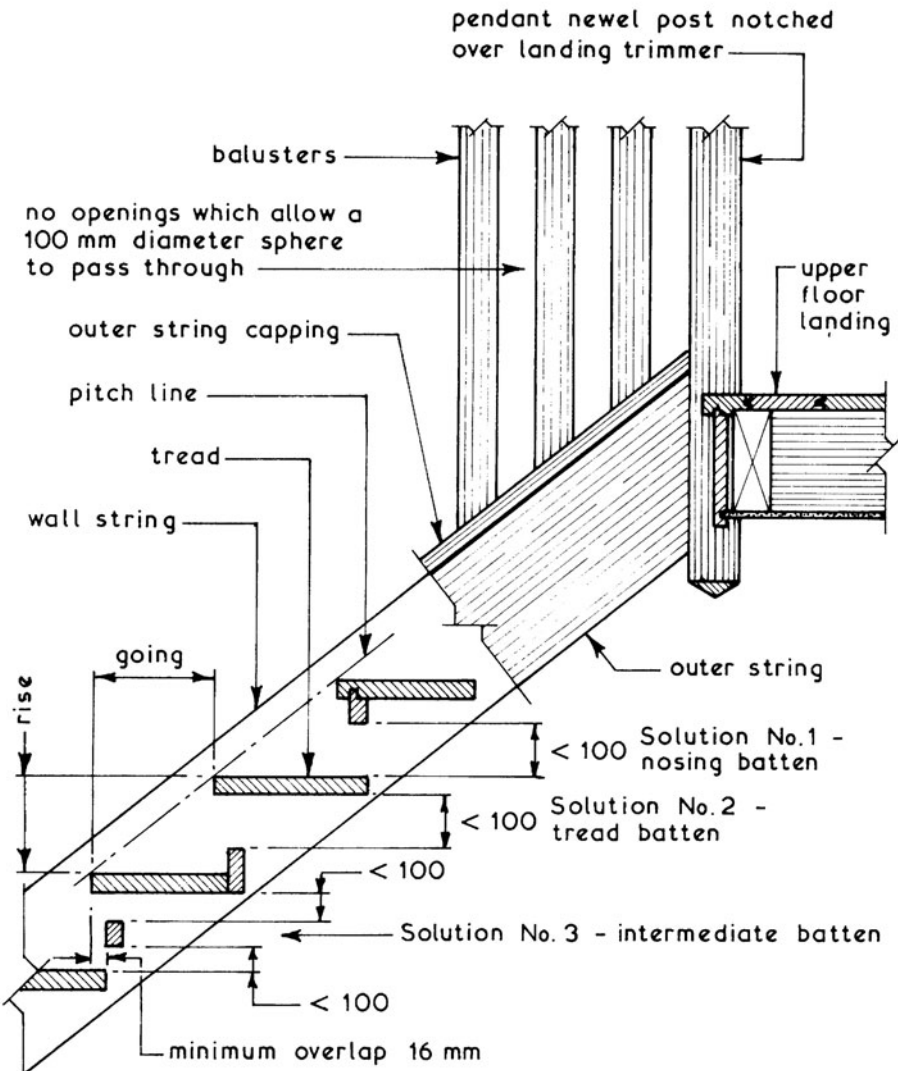

treads and battens housed and fixed into strings

## Alternating Tread Stairs

Application - a straight flight for access to a domestic loft conversion only. This can provide one habitable room, plus a bathroom or WC. The WC must not be the only WC in the dwelling.

Practical Issues - an economic use of space, achieved by a very steep pitch of about  $60^\circ$  and opposing overlapping treads.

Safety - pitch and tread profile differ considerably from other stairs, but they are acceptable to Building Regulations by virtue of 'familiarity and regular use' by the building occupants.

Additional features are:

- \* a non-slip tread surface.
- \* handrails to both sides.
- \* minimum going 220 mm.
- \* maximum rise 220 mm.
- \*  $(2 + \text{rise}) + (\text{going})$  between 550 and 700 mm.
- \* a stair used by children under 5 years old must have the tread voids barred to leave a gap not greater than 100 mm.

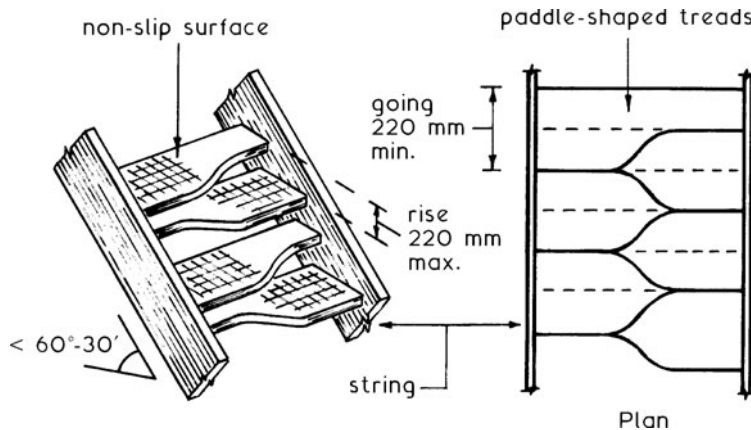

Ref. Building Regulations, Approved Document K1: Stairs, ladders and ramps: Section 1.29.

Timber Stairs ~ these must comply with the minimum requirements set out in Part K of the Building Regulations. Straight flight stairs are simple, easy to construct and install but by the introduction of intermediate landings stairs can be designed to change direction of travel and be more compact in plan than the straight flight stairs.

Landings ~ these are designed and constructed in the same manner as timber upper floors but due to the shorter spans they require smaller joist sections. Landings can be detailed for a 90° change of direction (quarter space landing) or a 180° change of direction (half space landing) and can be introduced at any position between the two floors being served by the stairs.

## Typical Layouts ~

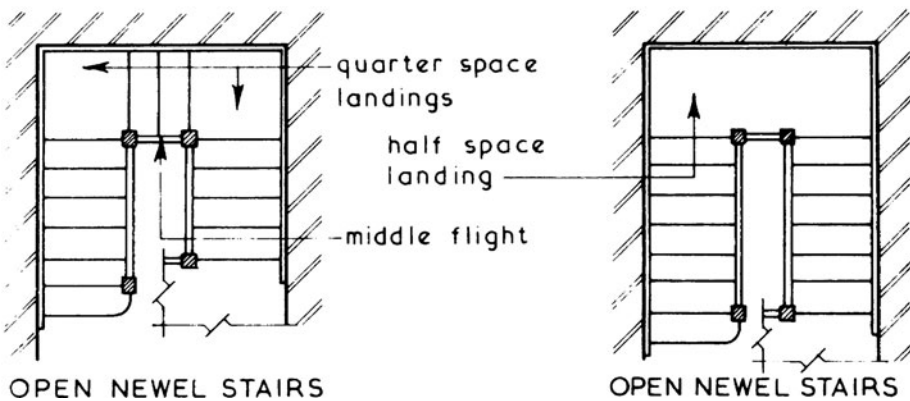
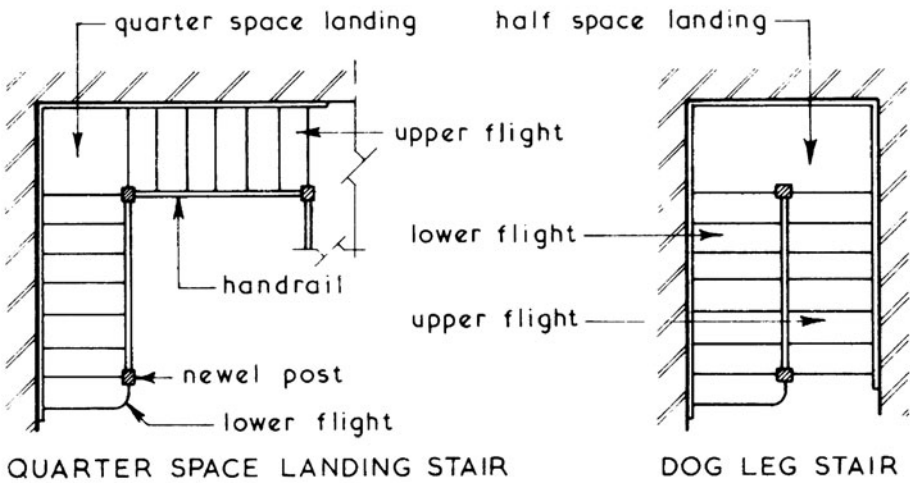



# Timber Stairs with Landings

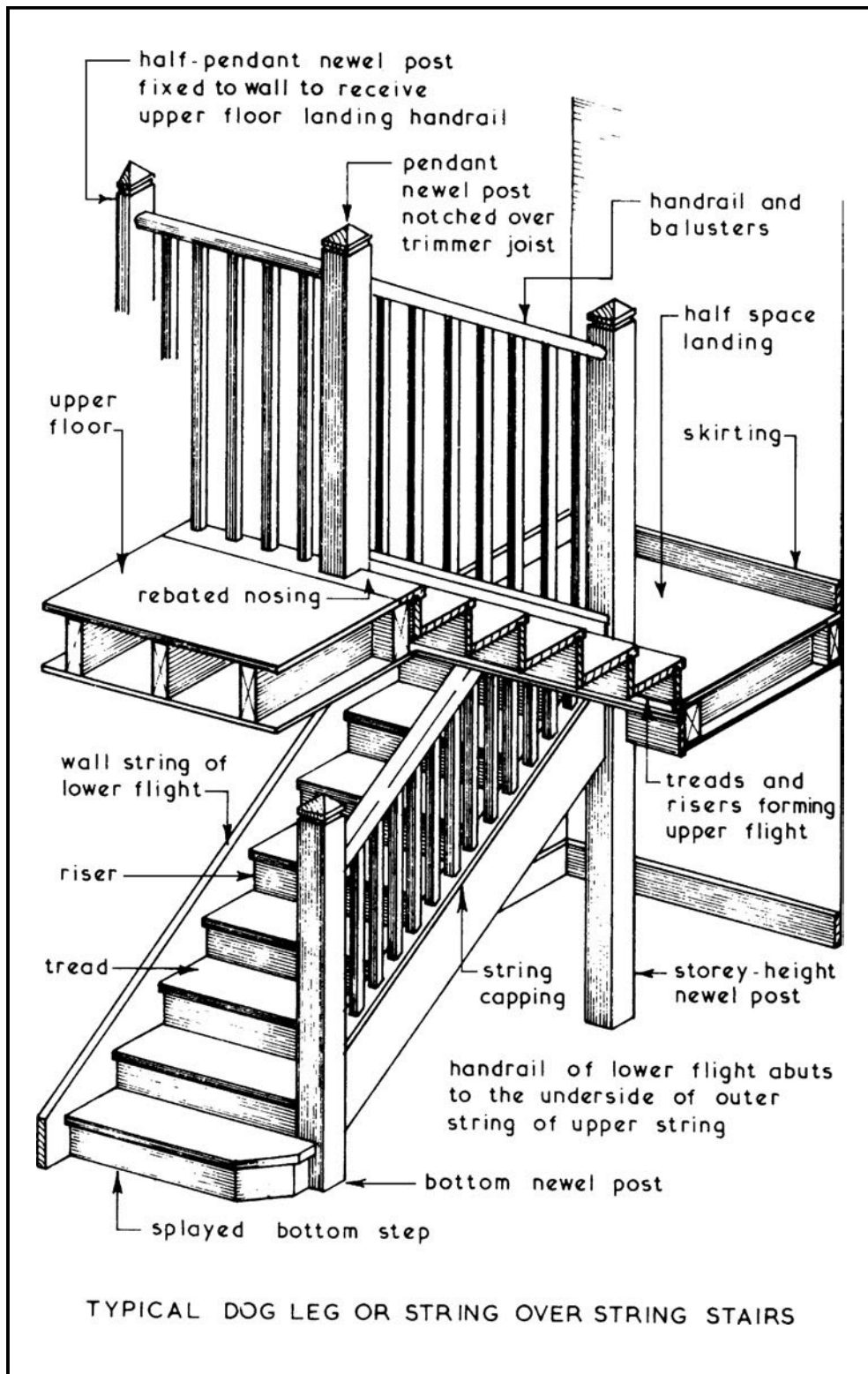

For domestic situations a spiral stair of 800mm clear width can provide an alternative compact, space-saving means of access to the upper floor of a private dwelling. With a clear width of only 600mm this type of stair may also be used to access the space available in a roof void. Approved Document K to the Building Regulations refers the design and application of spiral stairs to guidance in BS 5395-2, as summarised on pages 831 and 832.

## Typical timber spiral stair components

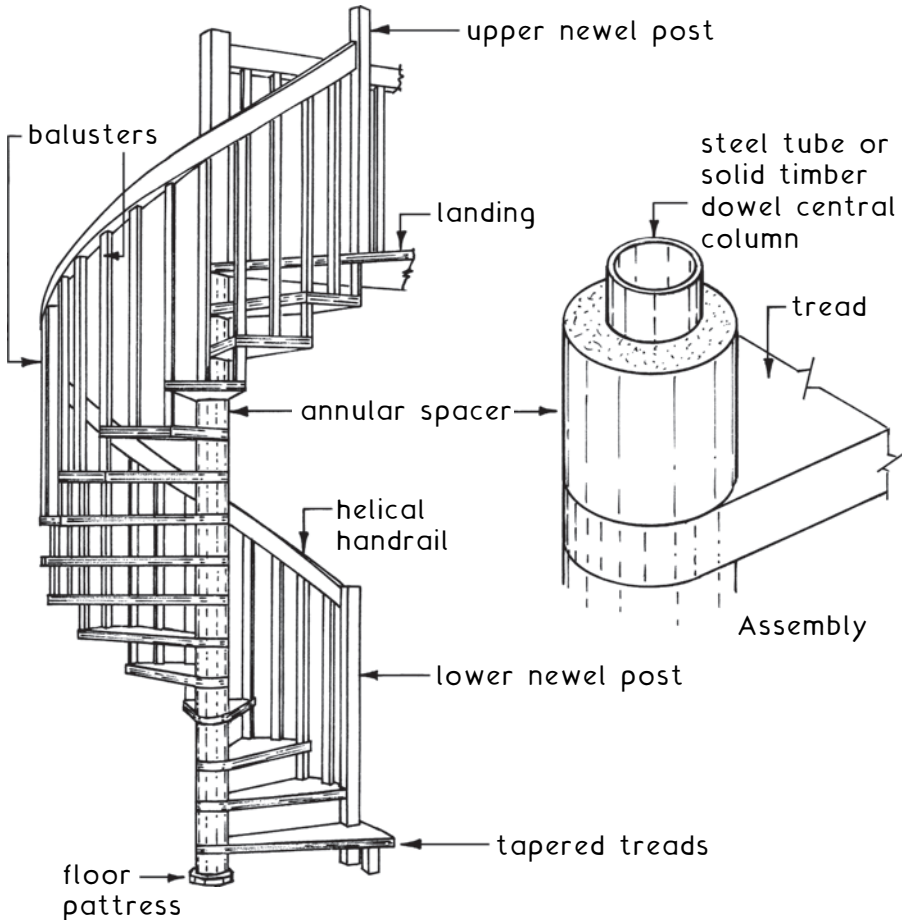

NB. Clear width is measured between handrails or between central column and handrail. If strings are used, measurement is to or between strings. Take greater value.

# In-situ RC Stairs

In-situ Reinforced Concrete Stairs ~ a variety of stair types and arrangements are possible each having its own appearance and design characteristics. In all cases these stairs must comply with the minimum requirements set out in Part K of the Building Regulations in accordance with the purpose group of the building in which the stairs are situated.

Typical Examples ~

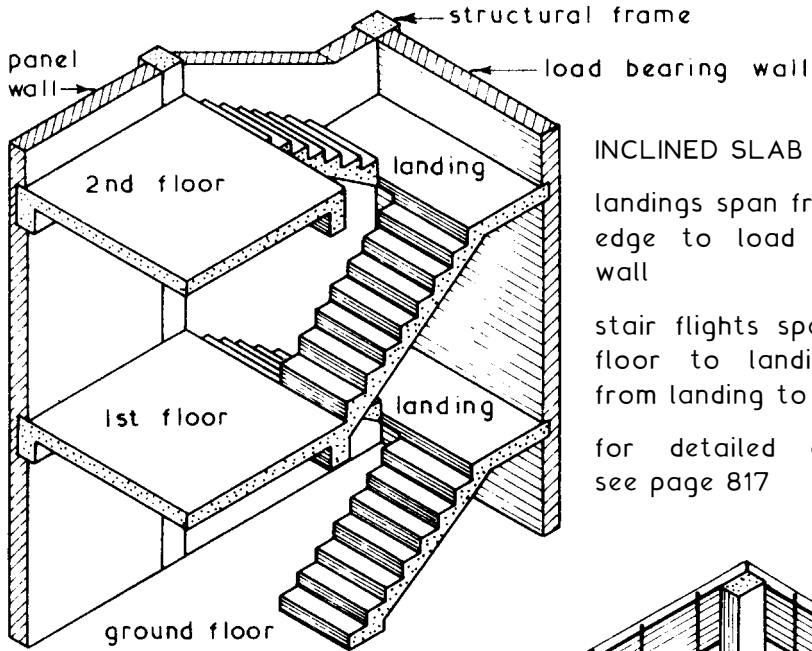

## INCLINED SLAB STAIR

landings span from well edge to load bearing wall

stair flights span from floor to landing and from landing to floor

for detailed example see page 817

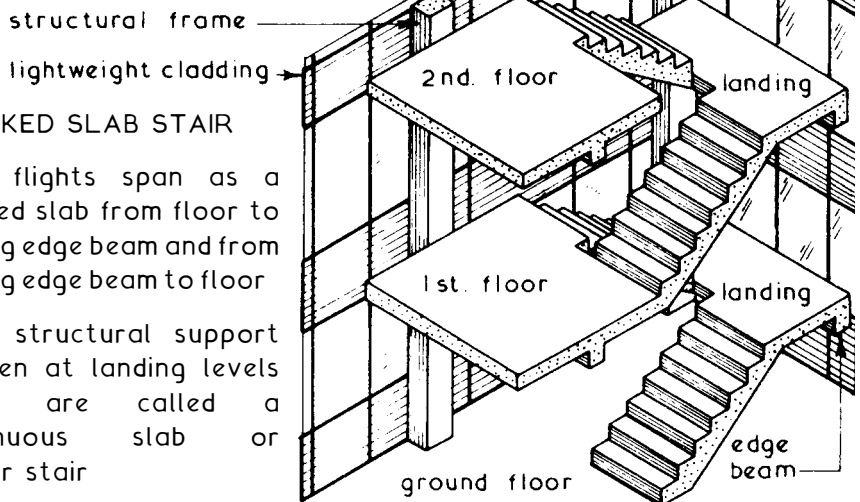

## CRANKED SLAB STAIR

Stair flights span as a cranked slab from floor to landing edge beam and from landing edge beam to floor

If no structural support is given at landing levels stairs are called a continuous slab or scissor stair

Typical Examples ~

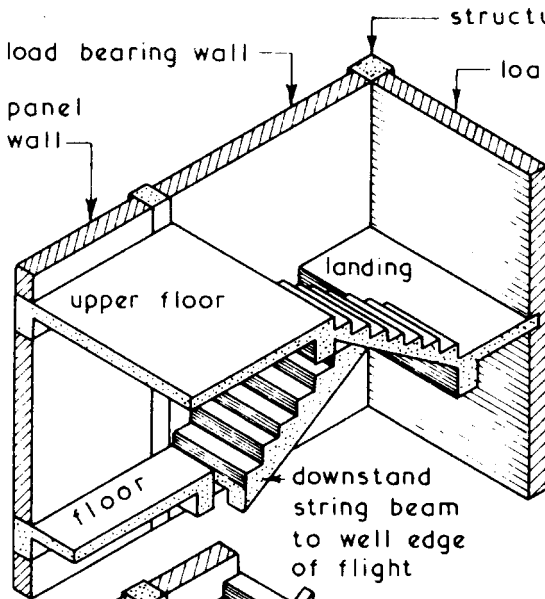

STRING BEAM STAIR

landings span from well edge beam to load bearing wall

string beams span from floor to landing and from landing to floor

stair flights span from string beam to load bearing wall or from string beam to string beam

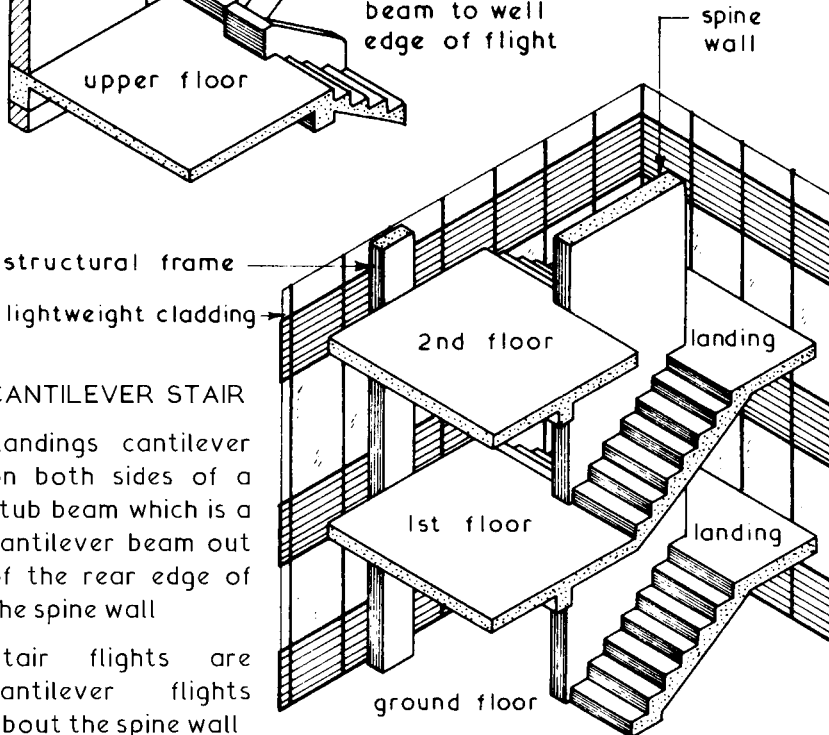
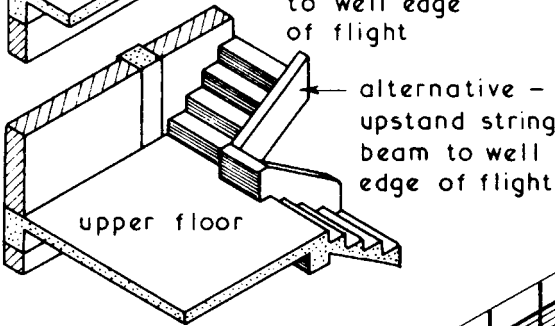

CANTILEVER STAIR

Landings cantilever on both sides of a stub beam which is a cantilever beam out of the rear edge of the spine wall

Stair flights are cantilever flights about the spine wall

## In-situ RC Stairs

Spiral and Helical Stairs ~ these stairs constructed in in-situ reinforced concrete are considered to be aesthetically pleasing but are expensive to construct. They are therefore mainly confined to prestige buildings usually as accommodation stairs linking floors within the same compartment. Like all other forms of stair they must conform to the requirements of Part K of the Building Regulations and if used as a means of escape in case of fire with the requirements of Part B. Spiral stairs can be defined as those describing a helix around a central column whereas a helical stair has an open well. The open well of a helical stair is usually circular or elliptical in plan and the formwork is built up around a vertical timber core.

Typical Example of a Helical Stair ~

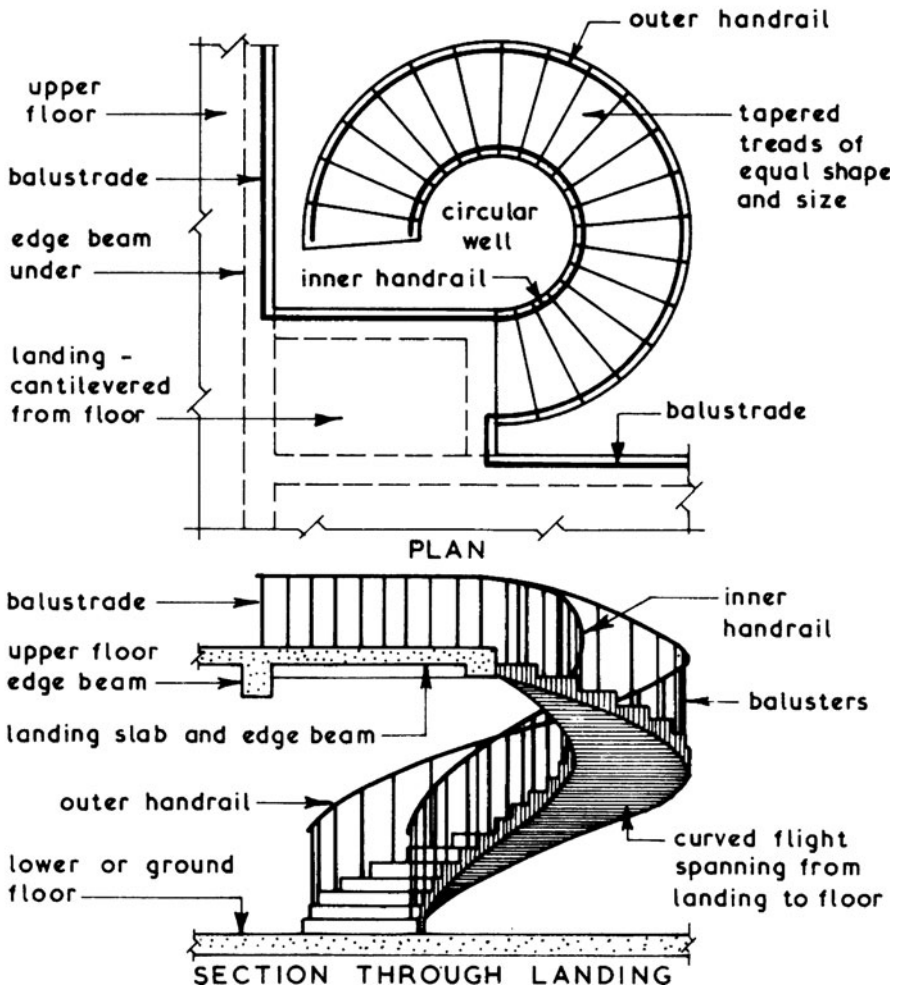

In-situ RC Inclined Slab Stair – Typical Details ~

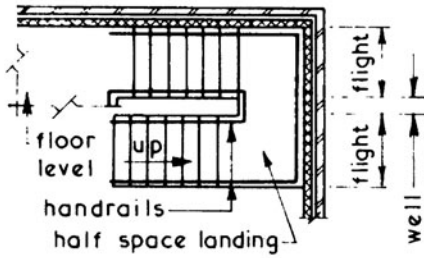

KEY PLAN

NB. in plan the risers in the upper flight are not in line with those in the lower flight. This is to ensure that the soffits of the two flights line through at their intersection with the soffit of the half space landing

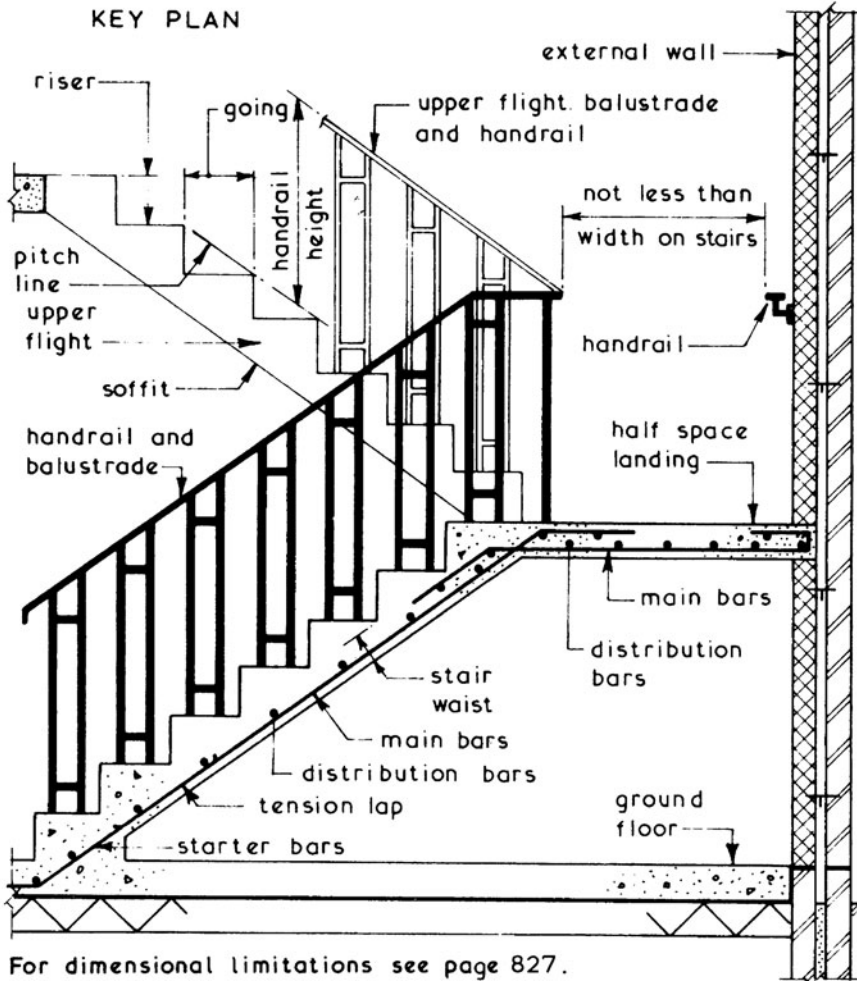

For dimensional limitations see page 827.

Stair width subject to AD B: Fire safety, and AD M: Access to and use of buildings. Width measured as clear distance between walls or balustrade. Ignore string and handrail if projecting <100 mm (AD B, Volume 2).

# In-situ RC Stairs – Formwork

In-situ Reinforced Concrete Stair Formwork ~ in specific detail the formwork will vary for the different types of reinforced concrete stair but the basic principles for each format will remain constant.

Typical RC Stair Formwork Details ~ (see previous page for Key Plan)

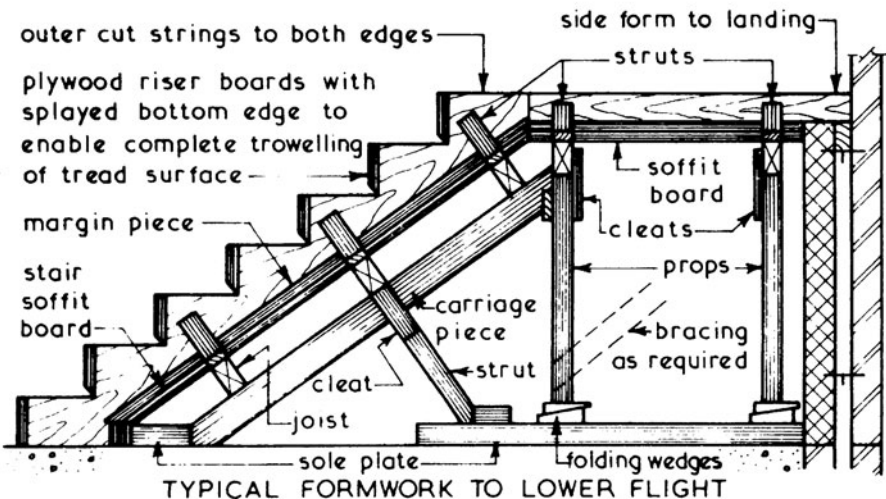
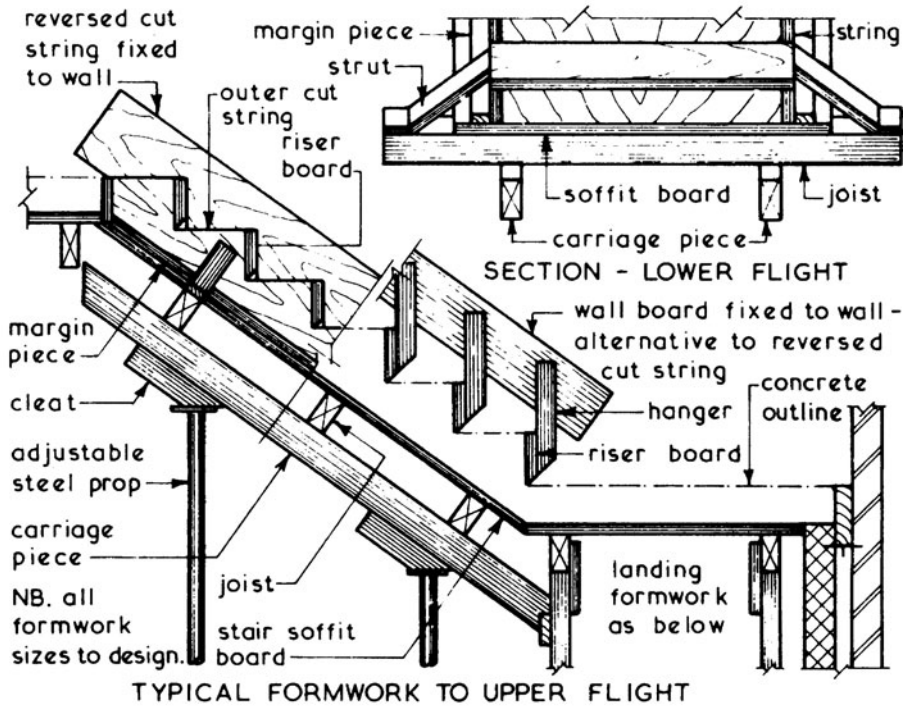

Precast Concrete Stairs ~ these can be produced to most of the formats used for in-situ concrete stairs and like those must comply with the appropriate requirements set out in Part K of the Building Regulations. To be economical the total production run must be sufficient to justify the costs of the moulds and therefore the designer's choice may be limited to the stair types which are produced as a manufacturer's standard item.

Precast concrete stairs can have the following advantages:

1. Good quality control of finished product.
2. Saving in site space since formwork fabrication and storage will not be required.
3. The stairs can be installed at any time after the floors have been completed, thus giving full utilisation to the stair shaft as a lifting or hoisting space if required.
4. Hoisting, positioning and fixing can usually be carried out by semi-skilled labour.

Typical Example ~ Straight Flight Stairs

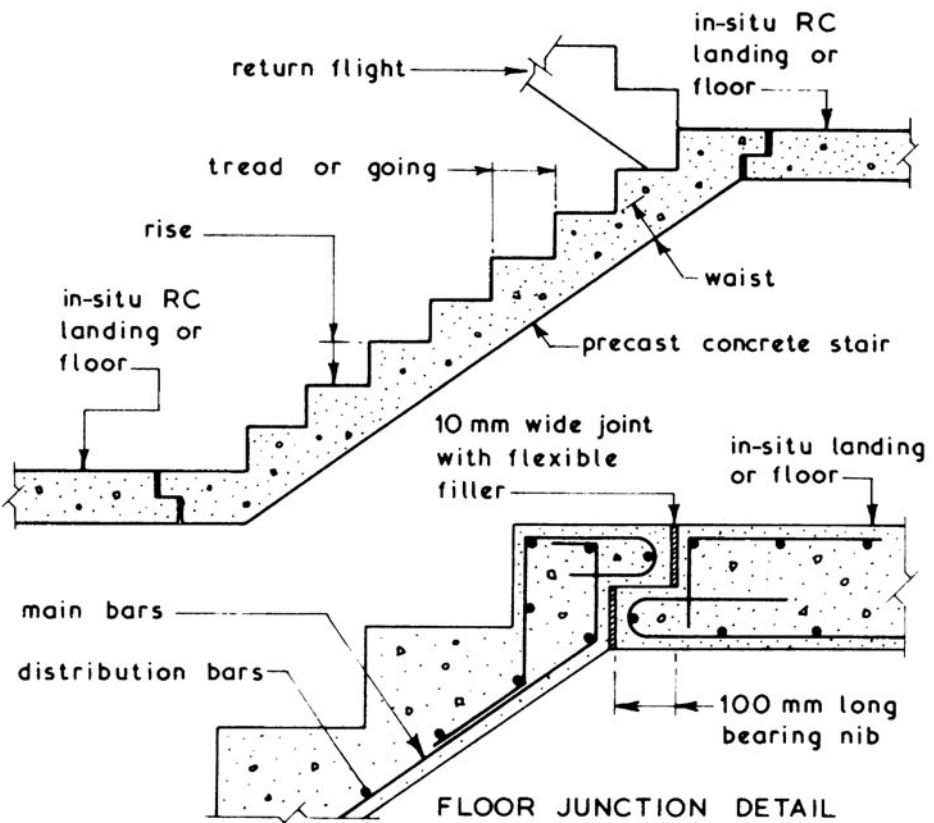



# Precast Concrete Stairs

Typical Example ~ Cranked Slab Stairs

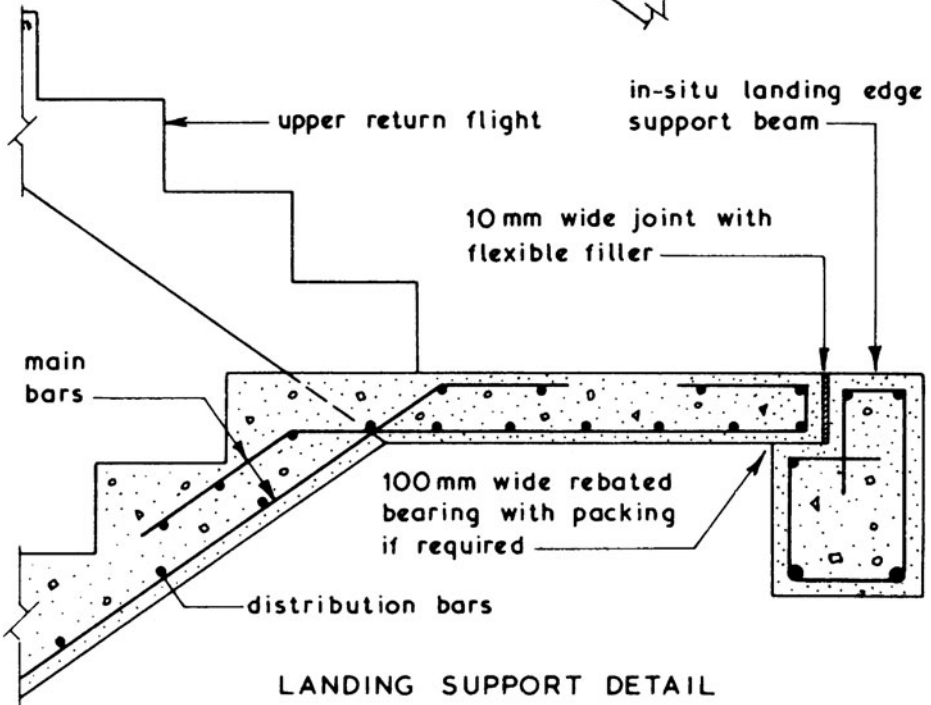
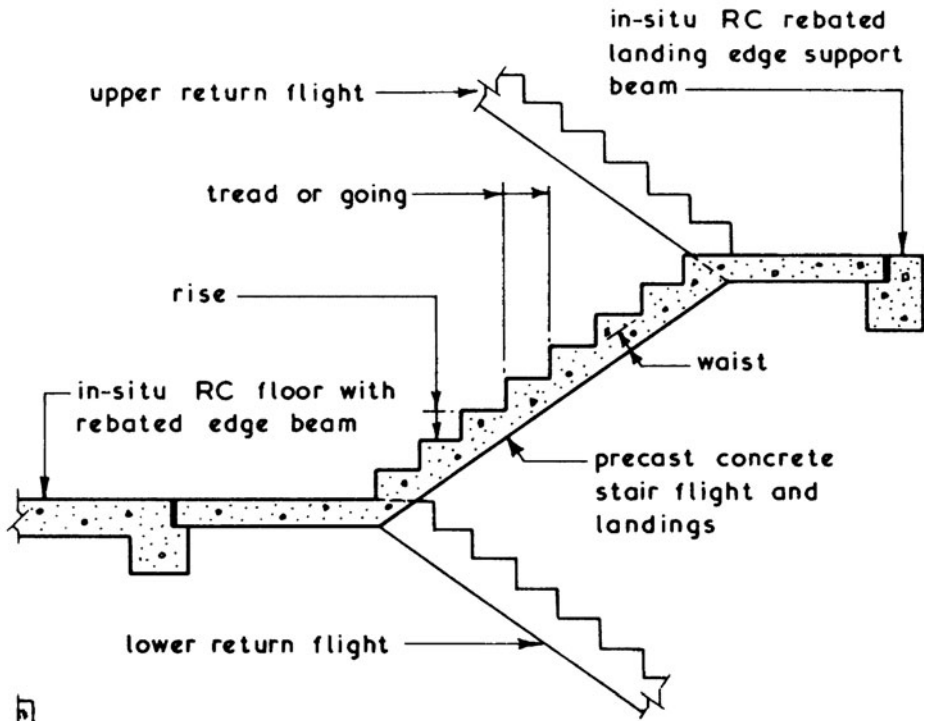

Typical Example ~ Spine Beam Stairs with Open Risers

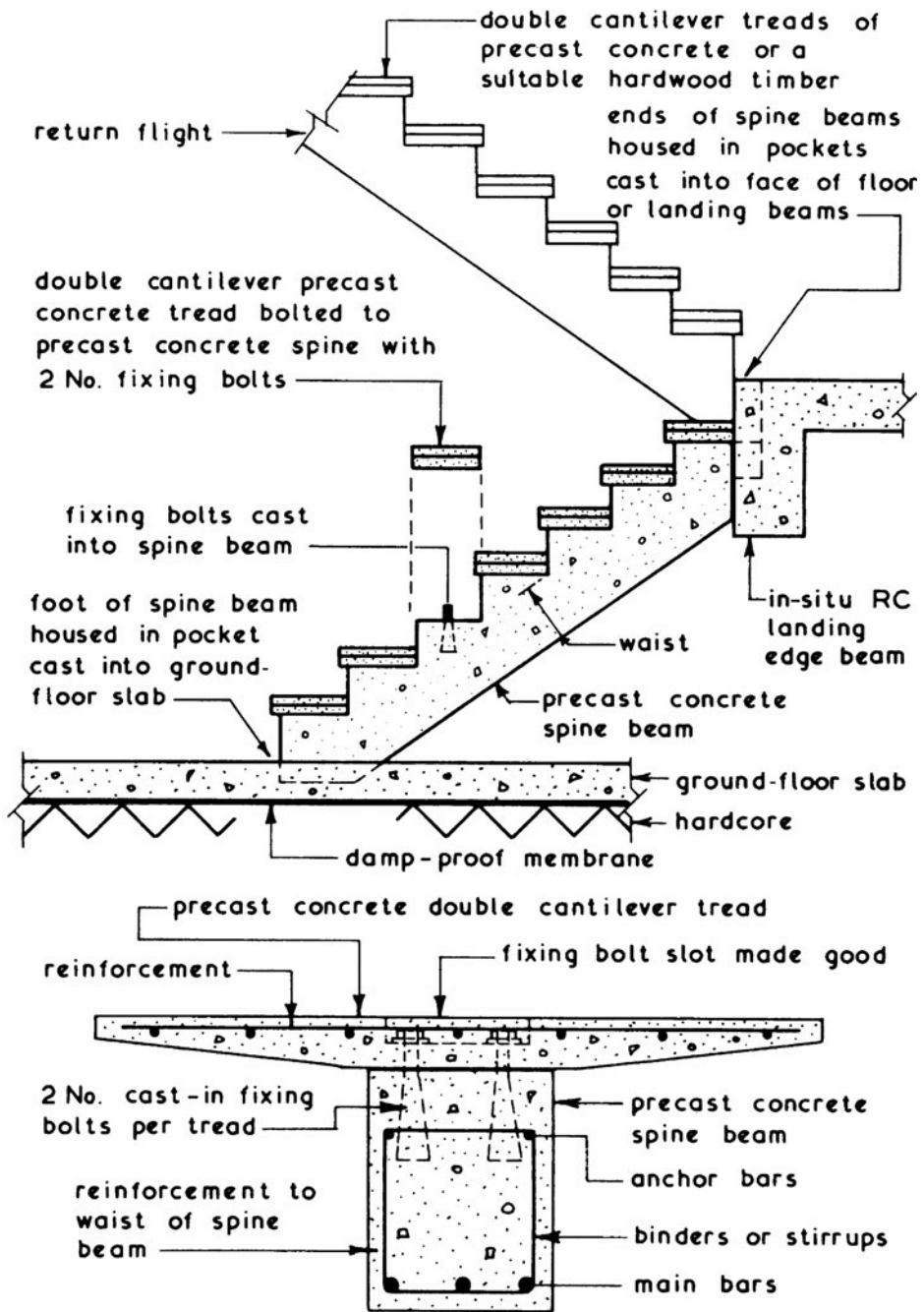

TYPICAL SECTION

# Precast Concrete Stairs

Precast Concrete Spiral Stairs ~ this form of stair is usually constructed with an open riser format using tapered treads which have a keyhole plan shape. Each tread has a hollow cylinder at the narrow end equal to the rise which is fitted over a central steel column usually filled with in-situ concrete. The outer end of the tread has holes through which the balusters pass to be fixed on the underside of the tread below, a hollow spacer being used to maintain the distance between consecutive treads.

Typical Example ~

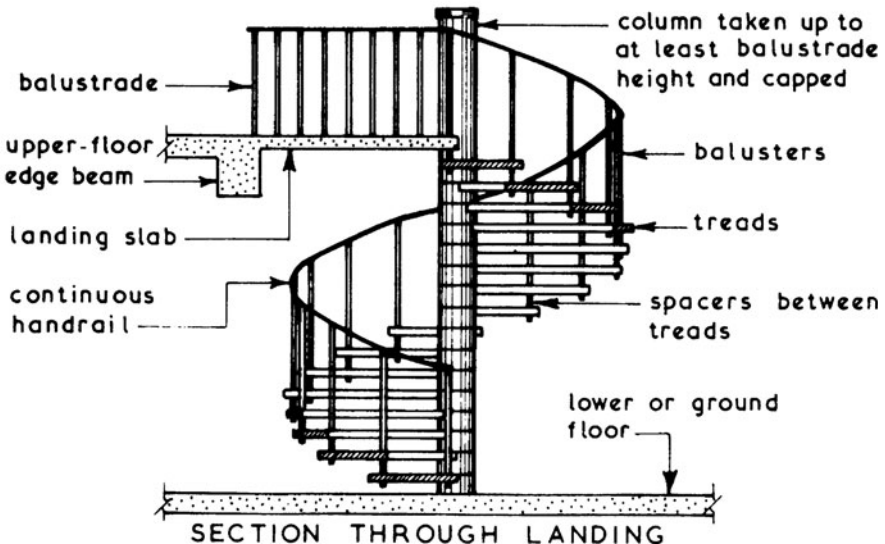
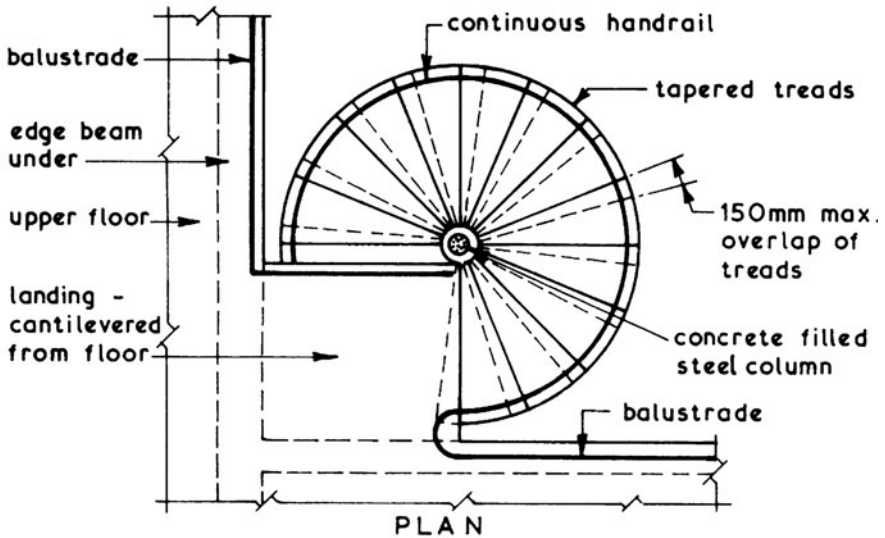

Metal Stairs ~ these can be produced in cast iron, mild steel or aluminium alloy for use as escape stairs or for internal accommodation stairs. Most escape stairs are fabricated from cast iron or mild steel and must comply with the Building Regulation requirements for stairs in general and fire escape stairs in particular. Most metal stairs are purpose made and therefore tend to cost more than comparable concrete stairs. Their main advantage is the elimination of the need for formwork whilst the main disadvantage is the regular maintenance in the form of painting required for cast iron and mild steel stairs.

Typical Example ~ Straight Flight Steel External Escape Stair

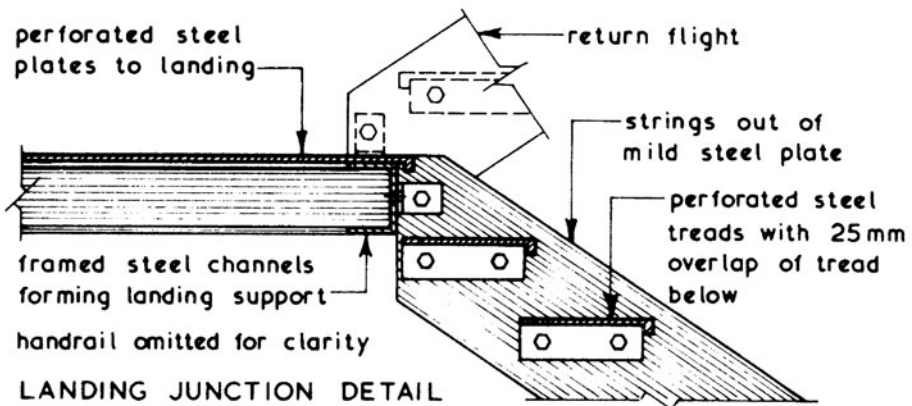
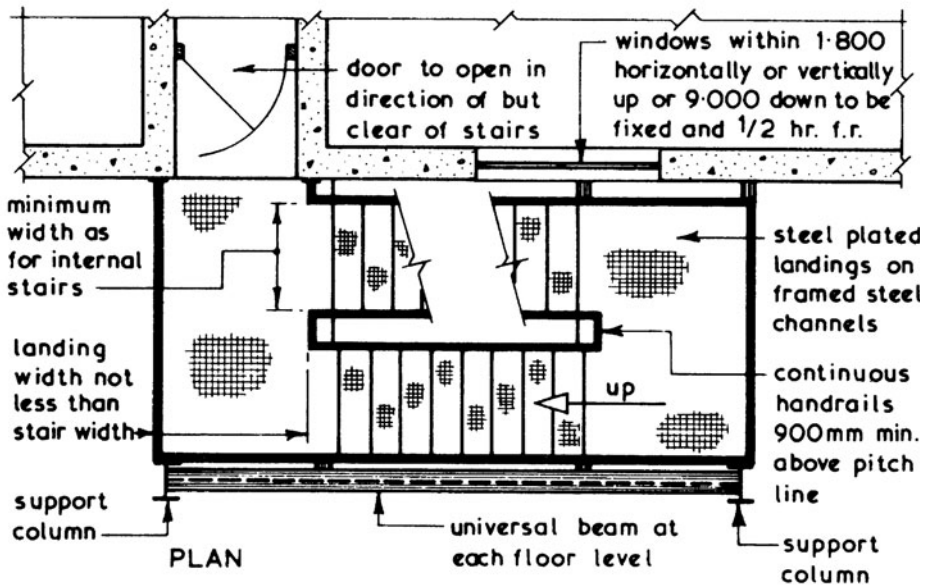

# Metal Stairs

## Typical Examples ~ Steel Spiral Stairs

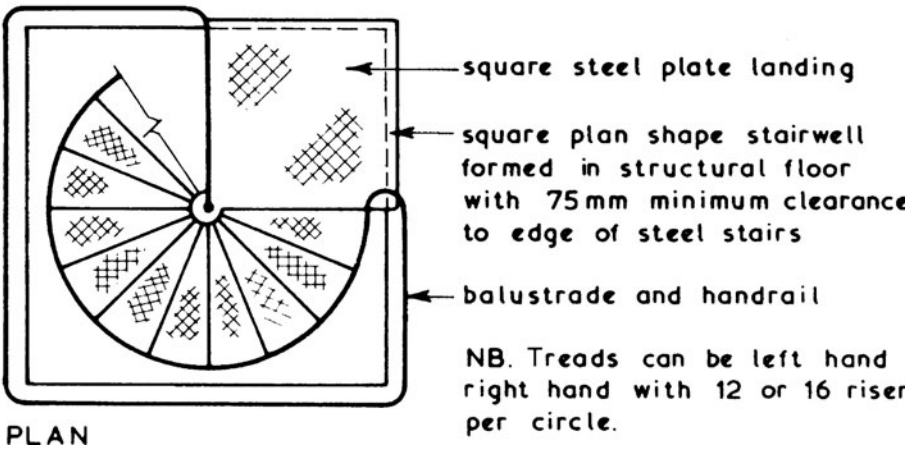
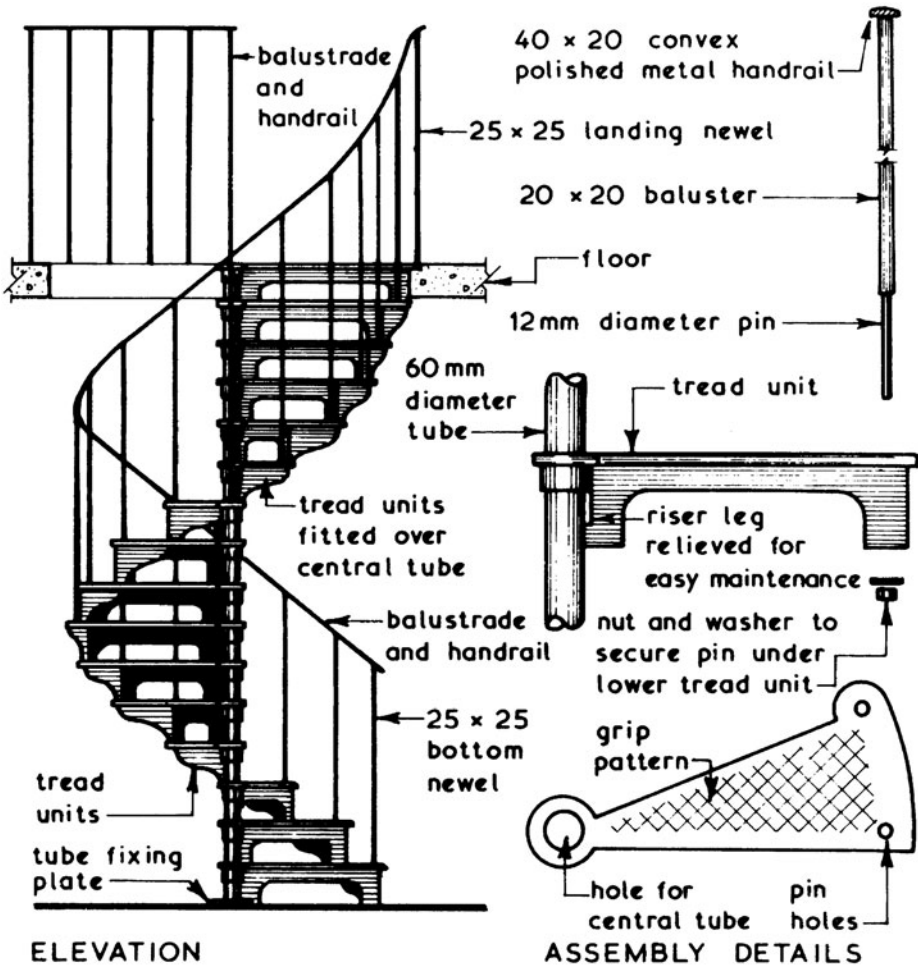

Typical Examples ~ Steel String Stairs

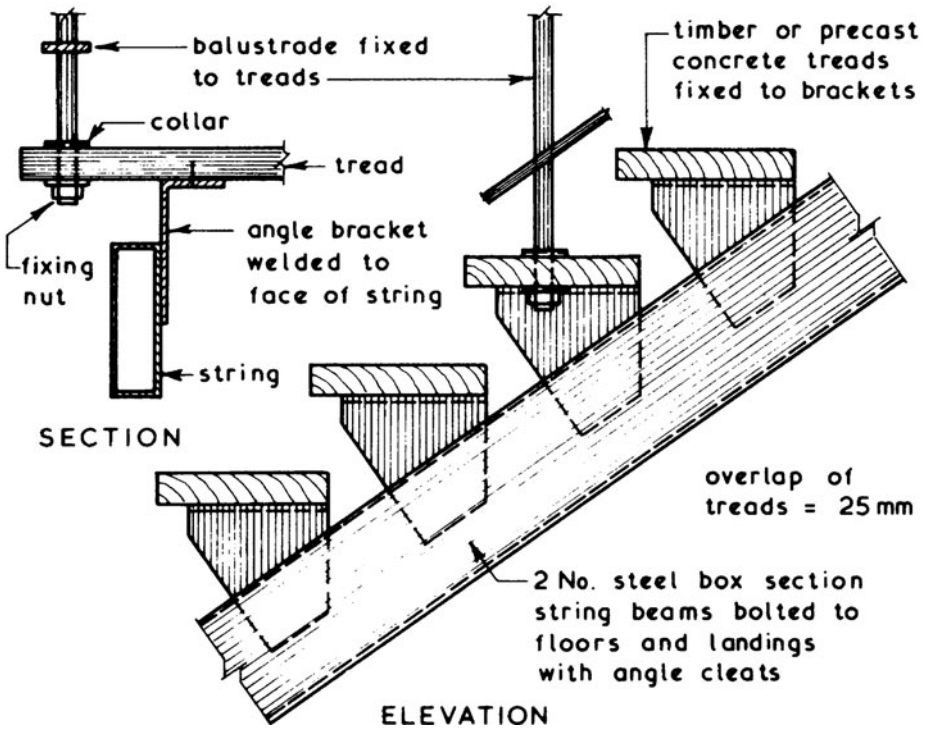
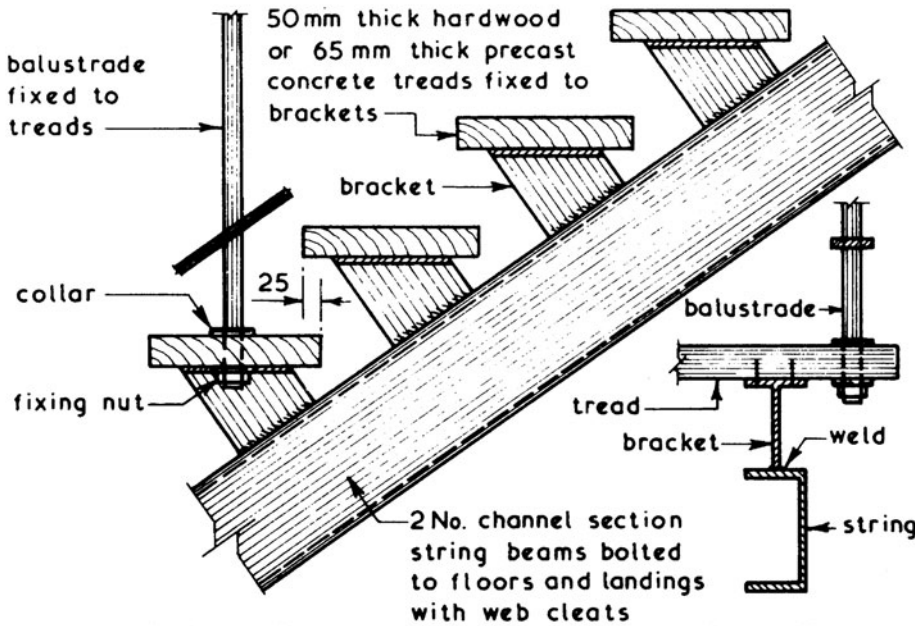

## Balustrades and Handrails

Balustrades and Handrails ~ these must comply in all respects with the requirements given in Part K of the Building Regulations and in the context of escape stairs are constructed of a non-combustible material with a handrail shaped to give a comfortable hand grip. The handrail may be covered or capped with a combustible material such as timber or plastic. Most balustrades are designed to be fixed after the stairs have been cast or installed by housing the balusters in a preformed pocket or by direct surface fixing.

Typical Details ~

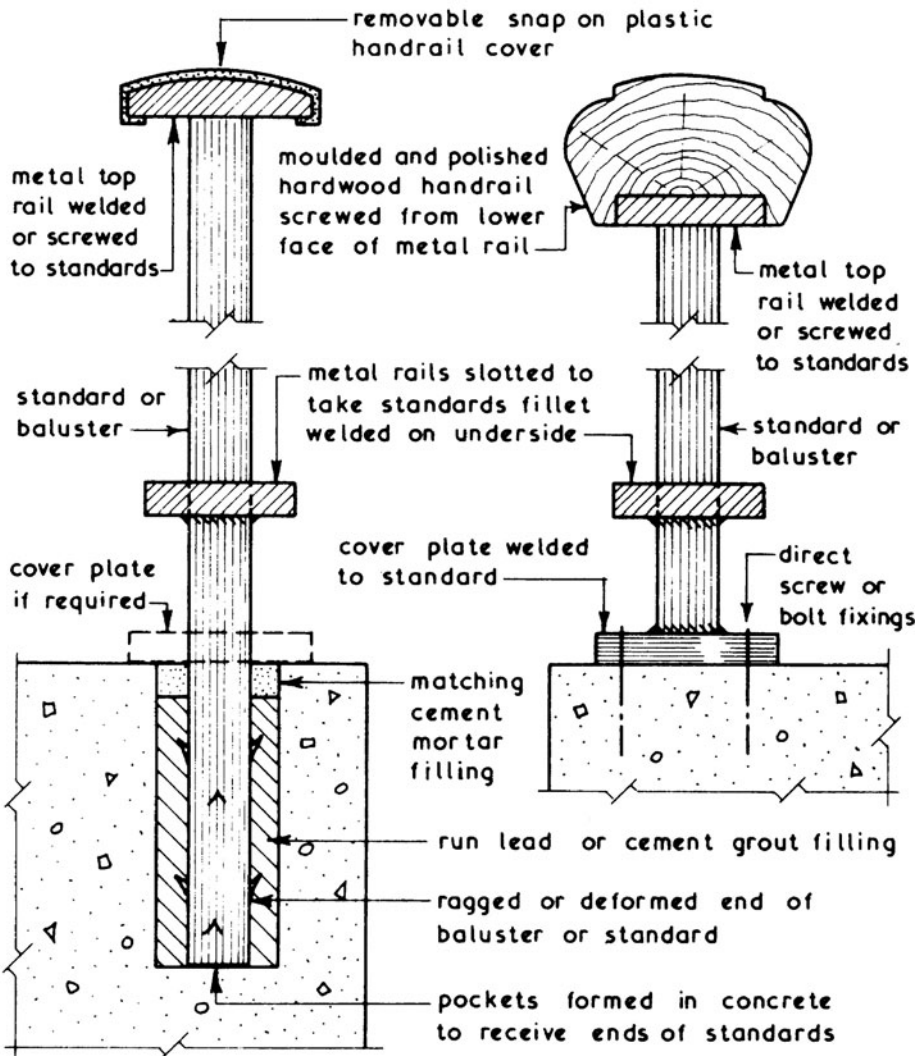

Institutional and Assembly Stairs ~ serving a place where a substantial number of people will gather.

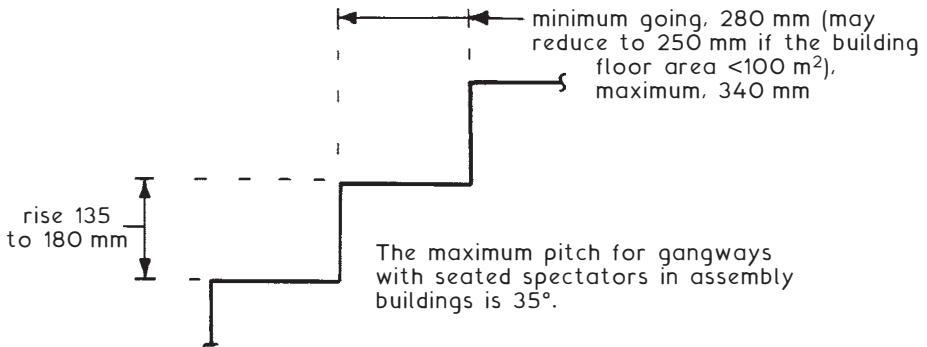

Other Stairs ~ all other buildings.

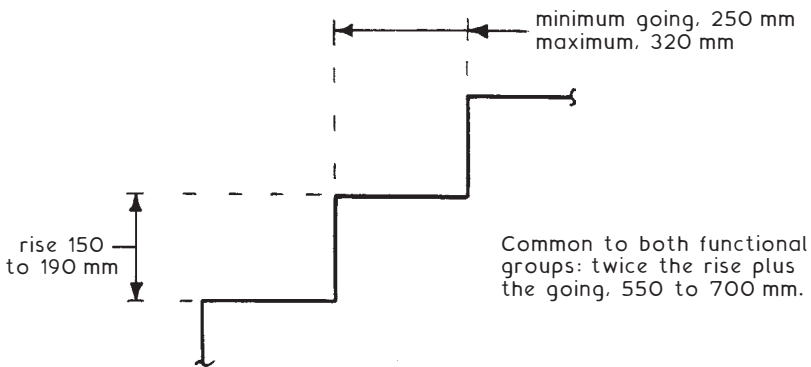

Alternative guidance: BS 5395-1: Code of practice for the design of stairs with straight flights and winders.

The rise and going in both situations may be subject to the requirements of Approved Document M: Access to and use of buildings. AD M will take priority and the following will apply:

- Going (external steps) ~ 280 mm minimum (300 mm min. preferred).
- Going (stairs) ~ 250 mm minimum.
- Rise ~ 170 mm maximum.

Other AD M requirements for stairs:

- Avoid tapered treads.
- Width at least 1200 mm between walls, strings or upstands.
- Landing top and bottom, minimum length not less than stair width.
- Handrails both sides; circular or oval preferred as shown on next page.
- Door openings onto landings to be avoided.
- Full risers, no gaps.
- Nosings with prominent colour 55 mm wide on tread and riser.
- Nosing projections avoided, maximum of 25 mm if necessary.
- Maximum 12 risers; exceptionally in certain small premises 16.
- Non-slip surface to treads and landing.



## Tapered Treads

### Measurement of the going (AD K) ~

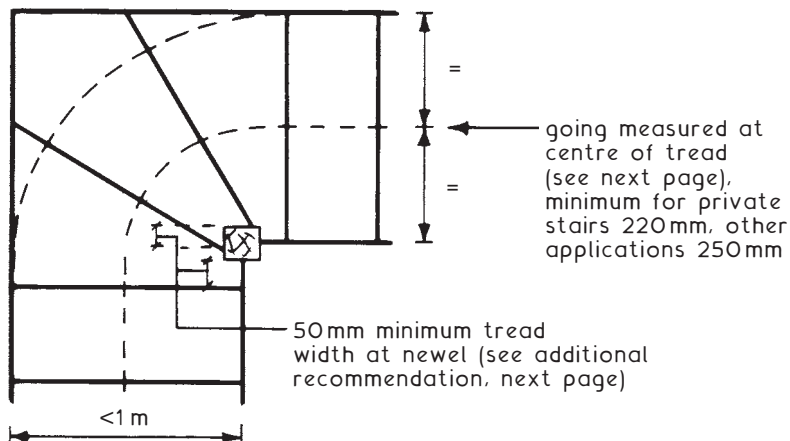

For stair widths greater than 1 m, the going is measured at 270 mm from each side of the stair.

### Additional requirements:

Going of tapered treads not less than the going of parallel treads in the same stair.

Curved landing lengths measured on the stair centre line.

Twice the rise plus the going, 550 to 700 mm.

Uniform going for consecutive tapered treads.

Other going and rise limitations as shown on the previous page and page 804.

Alternative guidance that provides reasonable safety for use in dwellings according to the requirements of Approved Document K is published in BS 585 - 1: Specification for stairs with closed risers for domestic use, including straight and winder flights and quarter or half landings.

### Handrail profile ~

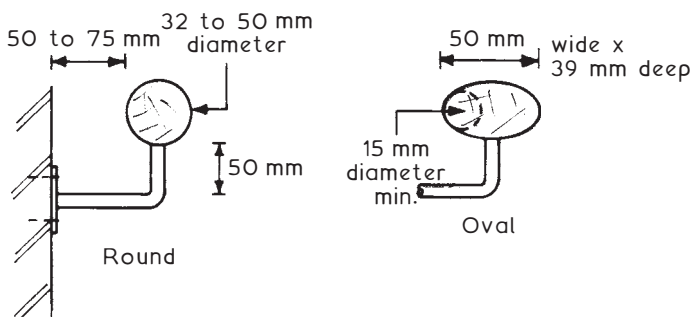

## Tapered Treads and Winder Flights (1)

Basic requirements:

- Lines of all risers to meet at one point, i.e. the geometric centre.
- Centre going to be uniform and not less than the going of adjacent straight flights.
- Centre going  $\geq$  going of adjacent parallel tread.
- Centre going  $\leq 700 - (2 \times \text{rise})$  in mm.
- Going at newel post, not less than 75mm.
- Taper angle of treads to be uniform.
- Clear width at least 770mm.

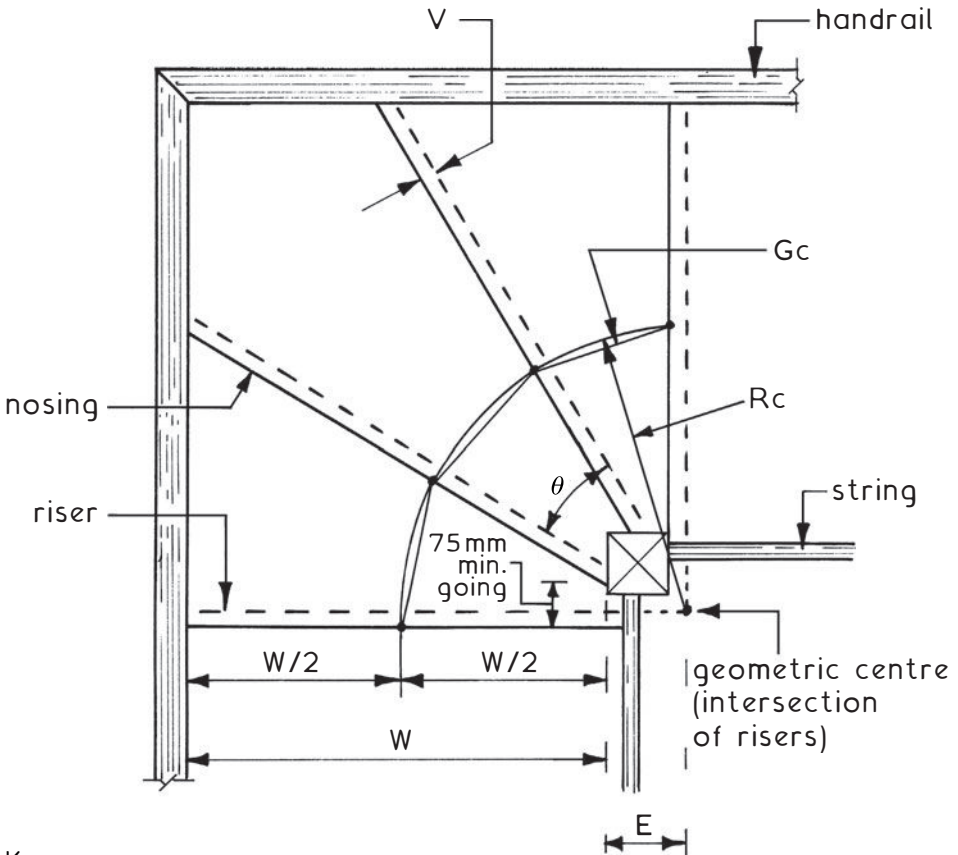

Key:

$G_c$  = centre going

$R_c$  = radius of arc given by equation (see next page)

$\theta$  = angle subtended by each tread

$W$  = clear width

$E$  = risers meeting point to edge of clear width

$V$  = nosing overhang

## Tapered Treads and Winder Flights (2)

To check whether the design for winder flights will comply with recommended dimensions, measurements can be taken from scale drawings or calculations may be applied.

Calculations ~

$$Gc = 2Rc (\sin \theta \div 2)$$

$$\text{where } Rc = \sqrt{([W \div 2] + E)^2 + (V)^2}$$

$$\text{E.g. } W = 770 \text{ mm}$$

$$E = 150 \text{ mm}$$

$$V = 16 \text{ mm}$$

$$Rc = \sqrt{([770 \div 2] + 150)^2 + (16)^2}$$

$$Rc = \sqrt{(385 + 150)^2 + 256}$$

$$Rc = \sqrt{(535)^2 + 256}$$

$$Rc = \sqrt{286225 + 256} = \sqrt{286481} = 535 \text{ mm}$$

$$Gc = 2 \times 535 (\sin 30^\circ \div 2)$$

$$\text{where } \sin 30^\circ = 0.5$$

$$Gc = 1070 \times (0.5 \div 2) = 267 \text{ mm}$$

In most applications the winder flight will turn through a  $90^\circ$  angle on plan. Therefore, the angle  $\theta$  subtended by each of three treads will be  $30^\circ$ , i.e.  $\theta = \text{turn angle} \div N$ , where  $N = \text{the number of winders}$ .

For four winders,  $\theta = 90^\circ \div 4 = 22.5^\circ$ .

If the turn angle is other than  $90^\circ$  then  $\theta = (180 - \text{turn angle}) \div N$ .

E.g. Turn angle of  $120^\circ$  with two winders,  $\theta = (180 - 120) \div 2 = 30^\circ$ .

Refs.: BS 585-1: Wood stairs. Specification for stairs with closed risers for domestic use, including straight and winder flights and quarter or half landings.

BS 5395-1: Code of practice for the design of stairs with straight flights and winders.

Summary recommendations of BS 5395-2:

Stair type <sup>1</sup>	Clear width <sup>2</sup>	Rise	Min. inner going <sup>3</sup>	Max. outer going <sup>4</sup>	Min. centre going <sup>5</sup>	2 × rise + going
A	600	170–220	120	350	145	480–800
B	800	170–220	120	350	190	480–800
C	800	170–220	150	350	230	480–800
D	900	150–190	150	450	250	480–800
E	1000	150–190	150	450	250	480–800

All dimensions in millimetres.

<sup>1</sup>See next page.

<sup>2</sup>Minimum clear width.

<sup>3</sup>270mm horizontally from inner handrail or column face if no handrail.

<sup>4</sup>270mm horizontally from outer handrail or string (take least value).

<sup>5</sup>Centre of clear width.

Clear headroom ~ measured from the pitch line (consecutive tread nosings at the geometric stair centre) vertically to any overhead obstruction. Normally 2.000m, but acceptable at 1.900m within 150mm of the centre column.

Landing ~ minimum angle subtended at the stair centre is 60°. Intermediate landings, minimum angle is 45° or a plan area ≥ two treads (take greater area).

Loading guide ~ (No. of treads × 0.2) + (1.5 for the landing)

E.g. 14 treads:

$$= (14 \times 0.2) + (1.5) = 4.3 \text{ kN.}$$

Refs.:

BS 5395-2: Stairs, ladders and walkways. Code of practice for the design of helical and spiral stairs.

Building Regulations, A.D. K: Protection from falling, collision and impact.

## Spiral Stairs (2)

BS 5395-2, Stair types:

### Category A ~

A small private stair for use by a limited number of people who are generally familiar with the stair. For example, an internal stair in a dwelling serving one room not being a living room or a kitchen. Also, an access stair to a small room or equipment room in an office, shop or factory not for public or general use. Subject to the provisions of A.D. B, possibly a fire escape for a small number of people. Typically, 1.300 to 1.800m overall diameter.

### Category B ~

Similar to category A, but providing the main access to the upper floor of a private dwelling. Typically, 1.800 to 2.250m overall diameter.

### Category C ~

A small semi-public stair for use by a limited number of people, some of whom may be unfamiliar with the stair. Examples include a stair in a factory, office or shop and a common stair serving more than one dwelling. Typically, 2.000 to 2.250m overall diameter.

### Category D ~

Similar to category C, but for use by larger numbers of people. Typically, 2.000 to 2.500m overall diameter.

### Category E ~

A public stair intended to be used by a large number of people at one time. For example, in a place of public assembly. Typically, 2.500 to 3.500m overall diameter.

Note 1: With regard to means of escape in the event of a fire, minimum widths given may be insufficient. All applications to satisfy the requirements of Building Regulations, Approved Documents B1 and B2: Fire safety. This has particular reference to stair clear width relative to the number of persons likely to use the stair and protection of the stairwell.

Note 2: In addition to an outer handrail, an inner handrail should be provided for categories C, D and E.

Functions ~ the main functions of any door are to:

1. Provide a means of access and egress.
2. Maintain continuity of wall function when closed.
3. Provide a degree of privacy and security.

Choice of door type can be determined by:

1. Position - whether internal or external.
2. Properties required - fire resistant, glazed to provide for borrowed light or vision through, etc.
3. Appearance - flush or panelled, painted or polished, etc.

Door Schedules ~ these can be prepared in the same manner and for the same purpose as that given for windows on page 446.

Internal Doors ~ these are usually lightweight and can be fixed to a lining, if heavy doors are specified these can be hung to frames in a similar manner to external doors. An alternative method is to use doorsets which are usually storey height and supplied with prehung doors.

Typical door Lining Details ~

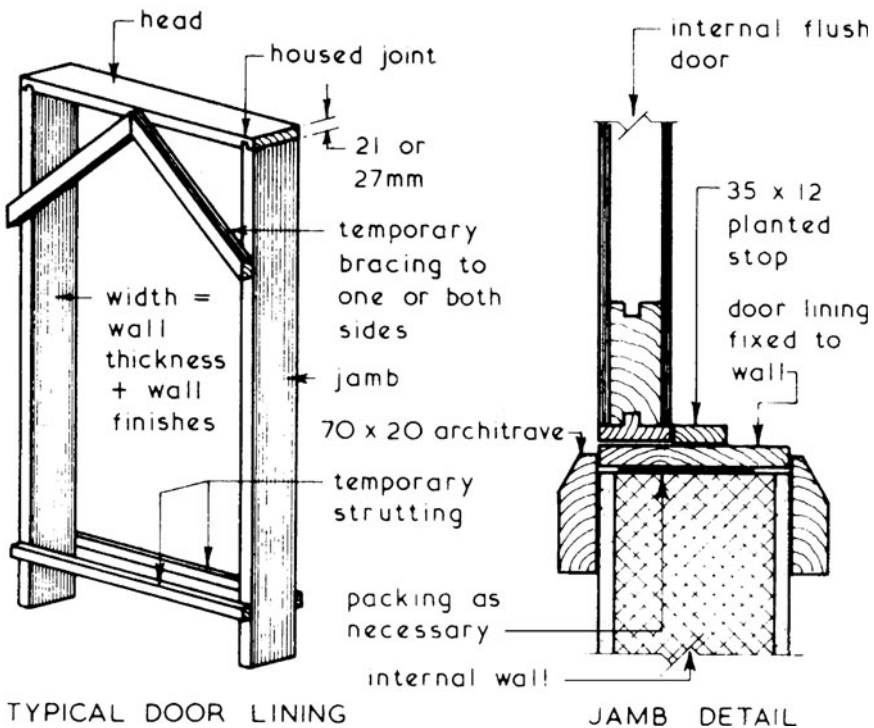

# Internal Doors

Internal Doors ~ these are similar in construction to the external doors but are usually thinner and therefore lighter in weight.

Typical Examples ~

common internal door size  
1981 high x 762 mm wide

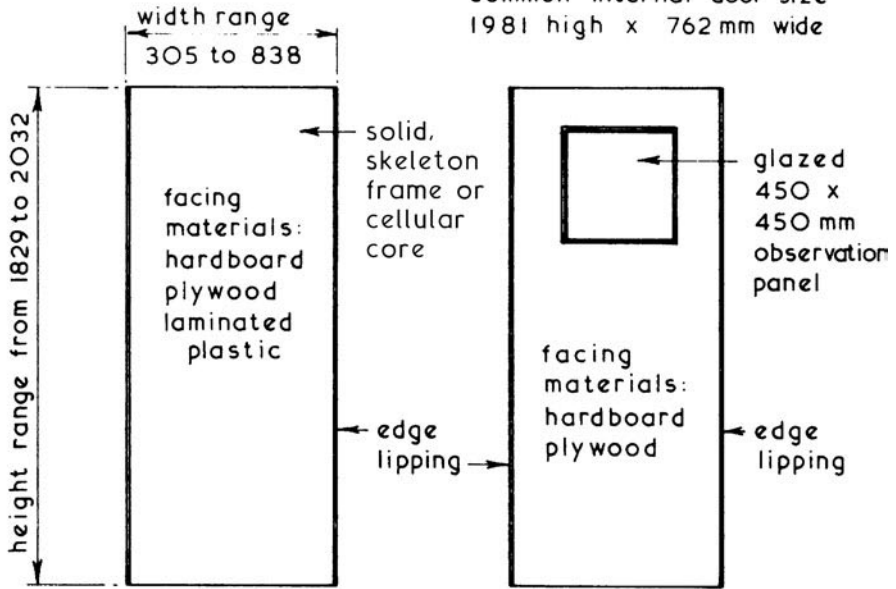

FLUSH DOOR

GLAZED FLUSH DOOR

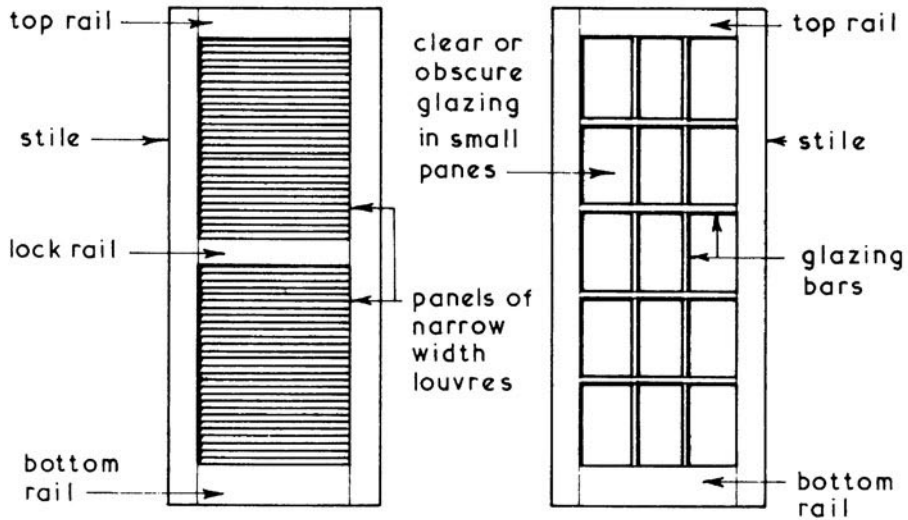

LOUVRED DOOR

GLAZED DOOR

Flush doors of lightweight construction are suitable to access many interior situations. If there is an additional requirement for resistance to fire, the construction will include supplementary lining as shown on pages 839 and 840. Fire resisting and non-fire resisting doors can be produced with identical flush finishes, but the fire doors must be purposely labelled as shown on page 838.

Examples of Non-fire Doors for Interior Use ~

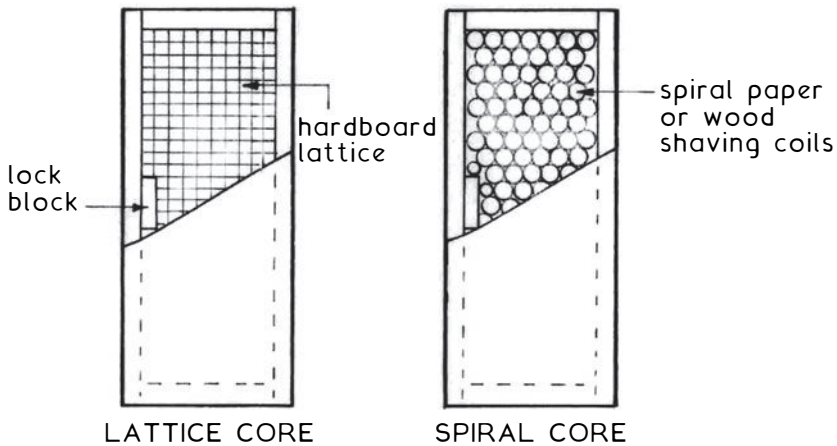
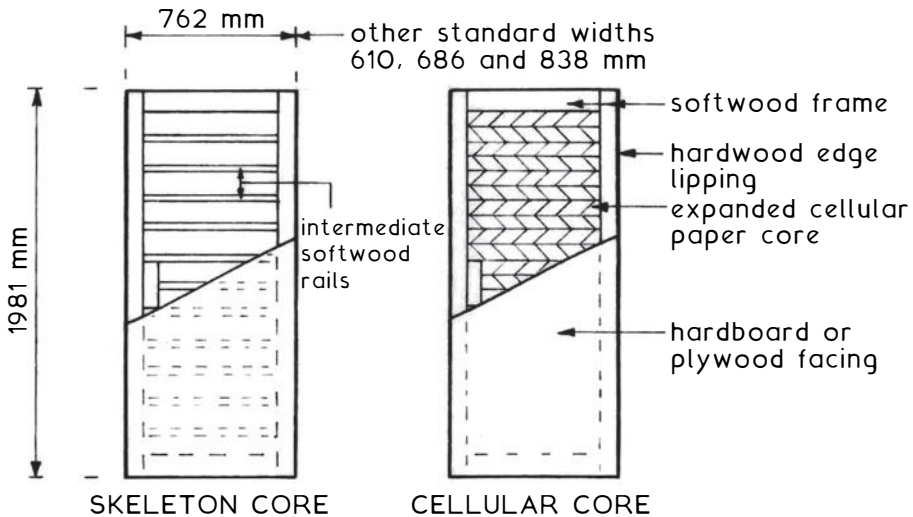

Note 1: Overall thickness can vary between manufacturers. Typically 35 or 40mm.

Note 2: Height and width dimension of 2032mm × 813mm also available from most joinery producers.



# Internal Door Frames

Internal Door Frames and Linings ~ these are similar in construction to external door frames but usually have planted door stops and do not have a sill. The frames are sized to be built in conjunction with various partition thicknesses and surface finishes. Linings with planted stops are usually employed for lightweight domestic doors. Typical Examples ~

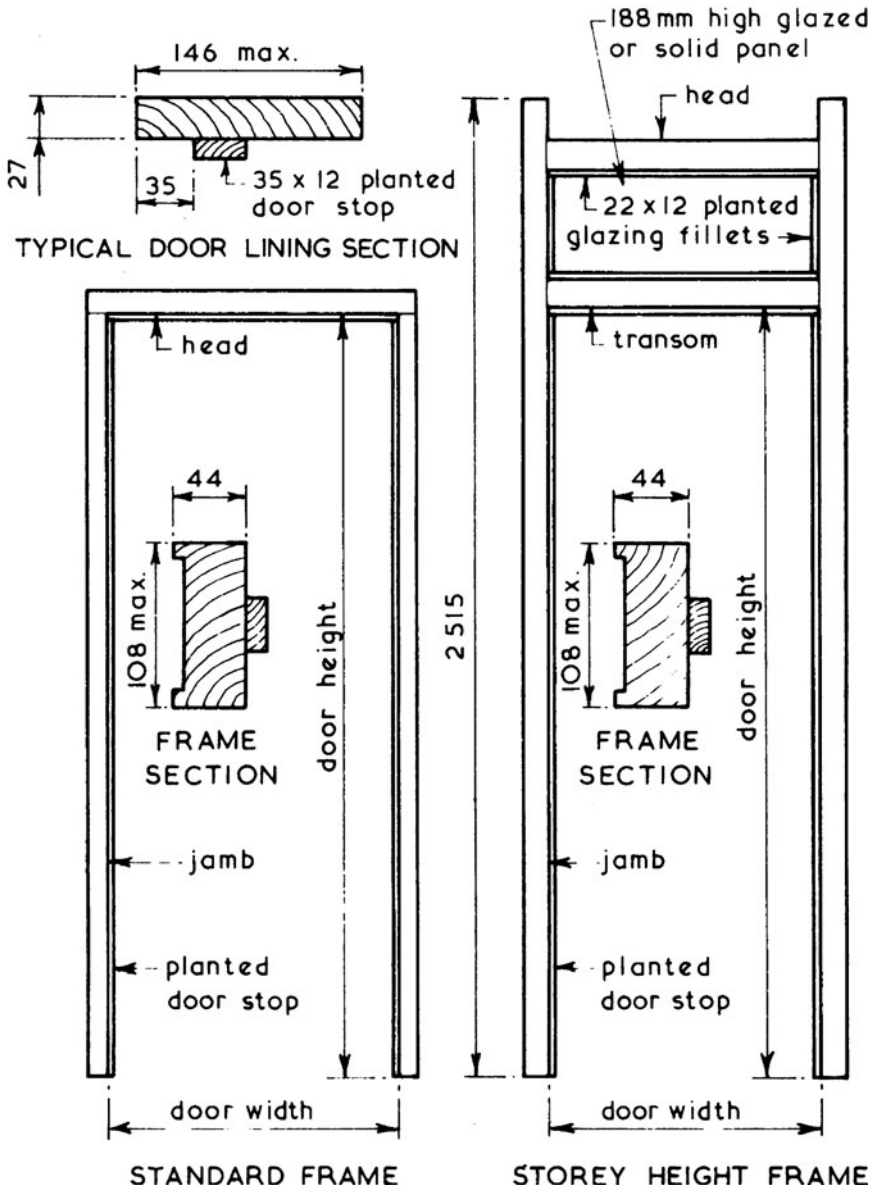

Ref. BS 4787: Internal and external wood doorsets, door leaves and frames. Specification for dimensional requirements.

Doorsets ~ these are factory-produced fully assembled prehung doors which are supplied complete with frame, architraves and ironmongery except for door furniture. The doors may be hung to the frames using pin butts for easy door removal. Prehung door sets are available in standard and storey height versions and are suitable for all internal door applications with normal wall and partition thicknesses.

Typical Examples ~

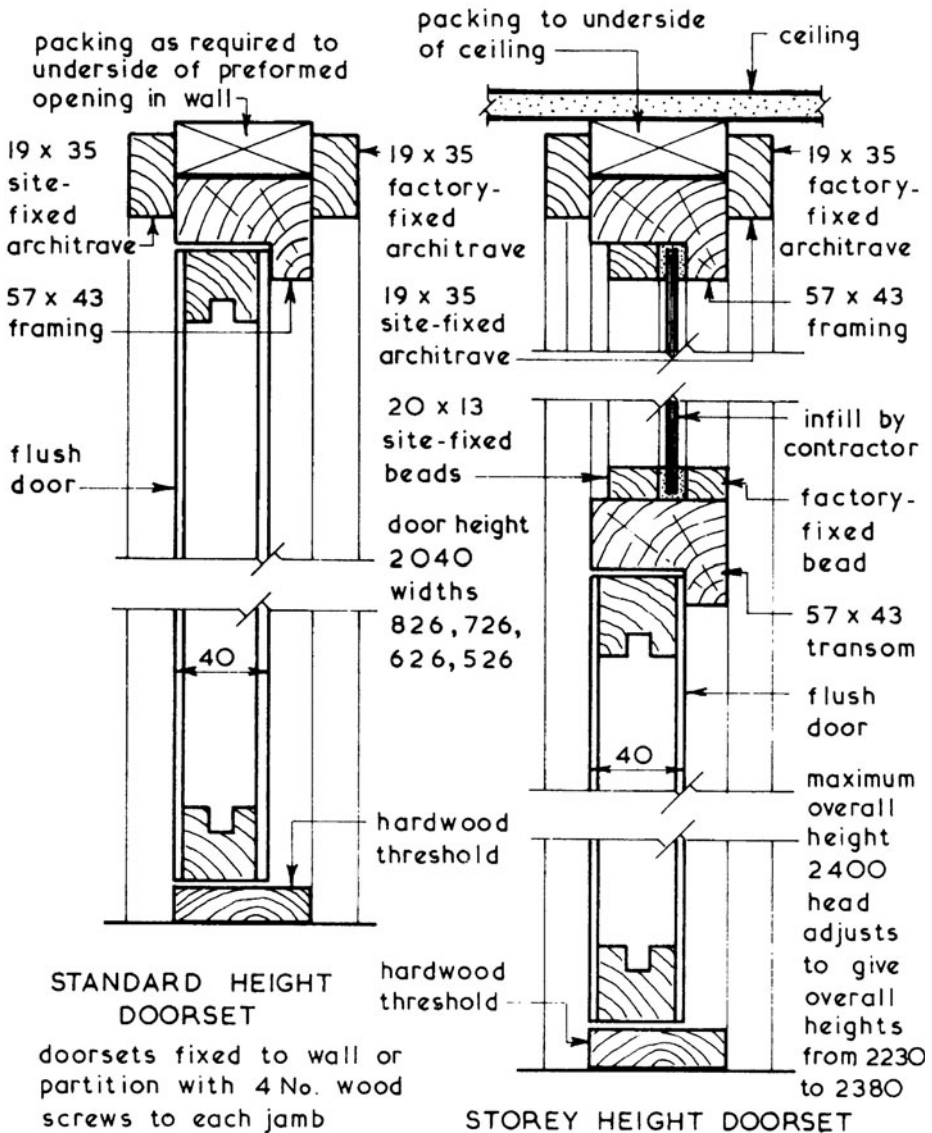

## Fire Doorsets and Fire Door Assemblies

Fire Doorset ~ a 'complete unit consisting of a door frame and a door leaf or leaves, supplied with all essential parts from a single source'. The difference between a doorset and a fire doorset is that the latter is endorsed with a fire certificate for the complete unit. When supplied as a collection of parts for site assembly, this is known as a door kit.

Fire Door Assembly ~ a 'complete assembly as installed, including door frame and one or more leaves, together with its essential hardware [ironmongery] supplied from separate sources'. Provided the components to an assembly satisfy the Building Regulations - Approved Document B, fire safety requirements and standards for certification and compatibility, then a fire door assembly is an acceptable alternative to a doorset.

Fire doorsets are usually more expensive than fire door assemblies, but assemblies permit more flexibility in choice of components. Site fixing time will be longer for assemblies.

(Quotes from BS EN 12519: Windows and pedestrian doors. Terminology.)

Fire Door ~ a fire door is not just the door leaf. A fire door includes the frame, ironmongery, glazing, intumescent core and smoke seal. To comply with European market requirements, ironmongery should be CE marked (see page 75). A fire door should also be marked accordingly on the top or hinge side. The label type shown below, reproduced with kind permission of the British Woodworking Federation, is acceptable.

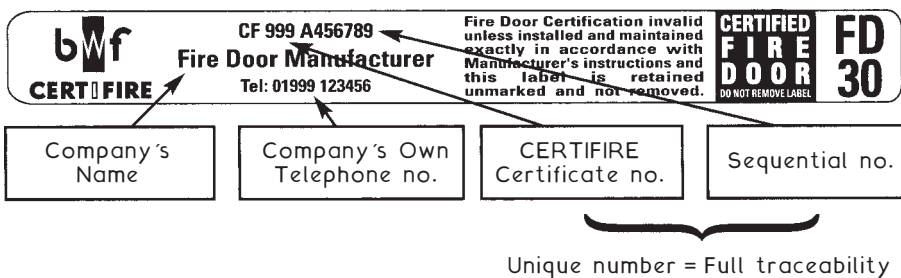

Ref. BS 8214: Code of practice for fire door assemblies.

30-minute Flush Fire Doors ~ these are usually based on the recommendations given in BS 8214. A wide variety of door constructions are available from various manufacturers but they all have to be fitted to a similar frame for testing as a doorset or assembly, including ironmongery.

A door's resistance to fire is measured by:

1. Insulation - resistance to thermal transmittance, see BS 476-20 & 22: Fire tests on building materials and structures.
2. Integrity - resistance in minutes to the penetration of flame and hot gases under simulated fire conditions.

Typical Details ~

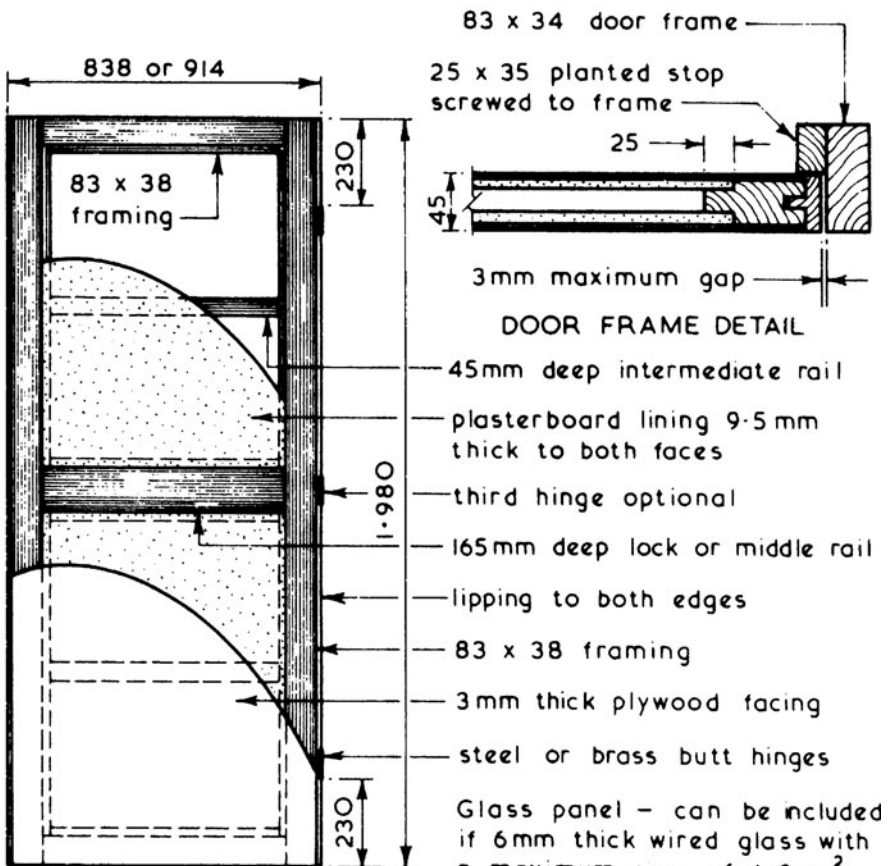

SECTIONAL ELEVATION

NB. intumescent strips in door edges provide an enhanced rating - see page 841.

Glass panel - can be included if 6mm thick wired glass with a maximum size of 1.2 m<sup>2</sup> is used. Glass to be fixed with non-combustible beads with a melting point of  $\leq 900^{\circ}\text{C}$ . See also page 842.

## 60-Minute Flush Fire Doors

60-minute Flush Fire Doors ~ like the 30-minute flush fire door shown on the previous page these doors are based on the recommendations given in BS 8214 which covers both door and frame. A wide variety of fire resistant door constructions are available from various manufacturers with most classified as having both insulation and integrity ratings of 60 minutes.

Typical Details ~

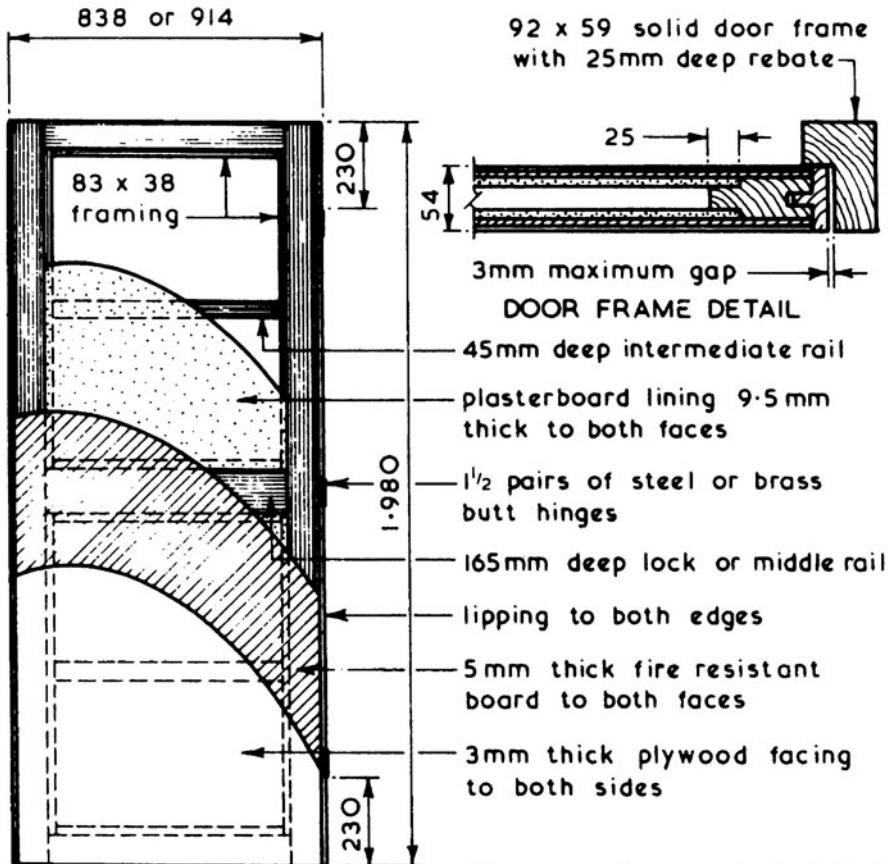

**SECTIONAL ELEVATION**  
NB. intumescent strips in door edges and frame rebate would give above door an enhanced rating ~ see next page.

Glass panel - can be included if 6mm thick wired glass with a maximum size of 0.5m<sup>2</sup> is used. Glass to be fixed with non-combustible beads with a melting point of  $\leq 900^{\circ}\text{C}$ . See also page 842.

Ref. BS 8214: Code of practice for fire door assemblies.

Fire and Smoke Resistance ~ doors can be assessed for both integrity and smoke resistance. They are coded accordingly, for example, FD30 or FD30s. FD indicates a fire door and 30 the integrity time in minutes. The letter 's' denotes that the door or frame contains a facility to resist the passage of smoke.

Manufacturers produce doors of standard ratings - 30, 60 and 90 minutes, with higher ratings available to order. A colour-coded plug inserted in the door edge corresponds to the fire rating. See BS 8214, Table 1 for details.

## Intumescent Fire and Smoke Seals ~

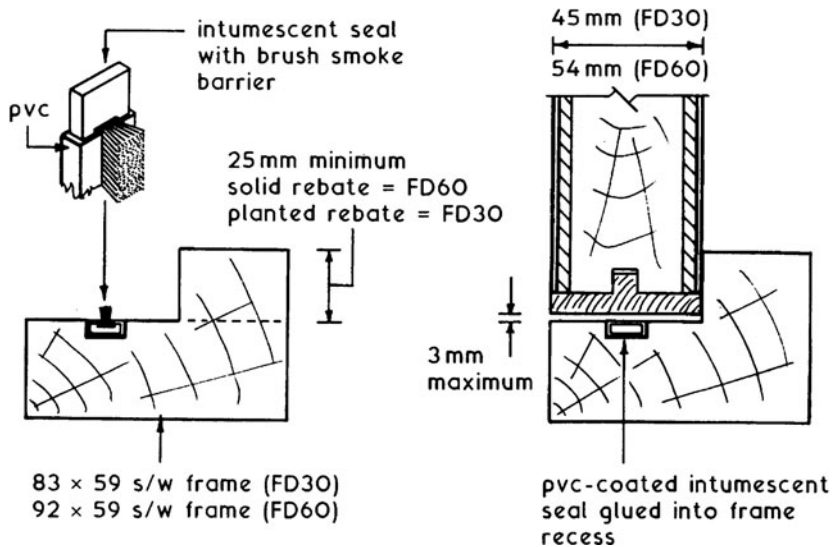

The intumescent core may be fitted to the door edge or the frame. In practice, most joinery manufacturers leave a recess in the frame where the seal is secured with rubber-based or PVA adhesive. At temperatures of about 150°C, the core expands to create a seal around the door edge. This remains throughout the fire-resistance period whilst the door can still be opened for escape and access purposes. The smoke seal will also function as an effective draught seal.

Further refs.:

BS EN 1634-1: Fire resistance and smoke control tests for door, shutter and openable window assemblies and elements of building hardware.

BS EN 13501: Fire classification of construction products and building elements.

## Fire Doors – Vision Panels

Apertures will reduce the potential fire resistance if not appropriately filled. Suitable material should have the same standard of fire performance as the door into which it is fitted.

Fire-rated glass types:

- Embedded Georgian wired glass
- Composite glass containing borosilicates and ceramics
- Tempered and toughened glass
- Glass laminated with reactive fire-resisting interlayers

Installation ~ hardwood beads and intumescent seals. Compatibility of glass type and sealing product is essential, therefore manufacturer's details must be consulted.

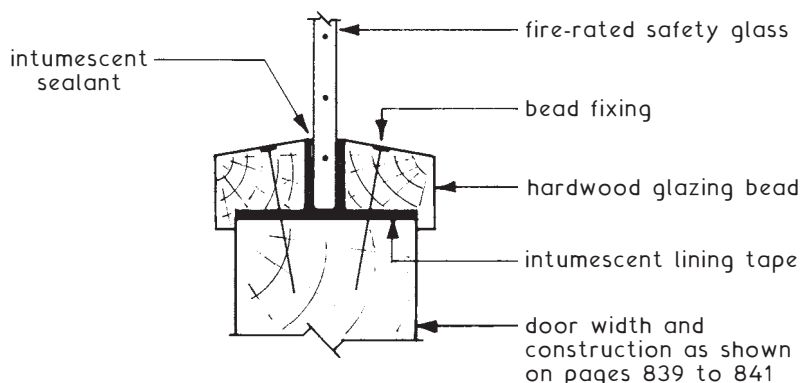

Intumescent products:

- Sealants and mastics 'gun' applied
- Adhesive glazing strip or tape
- Preformed moulded channel

Note: Calcium silicate preformed channel is also available. Woven ceramic fire-glazing tape/ribbon is produced specifically for use in metal frames.

Building Regulations refs.:

A.D. M, Section 3.10, visibility zones/panels between 500 and 1500 mm above floor finish, and A.D. K, Section 10.

A.D. K, Section 5, aperture size (see page 458).

Typical Details ~

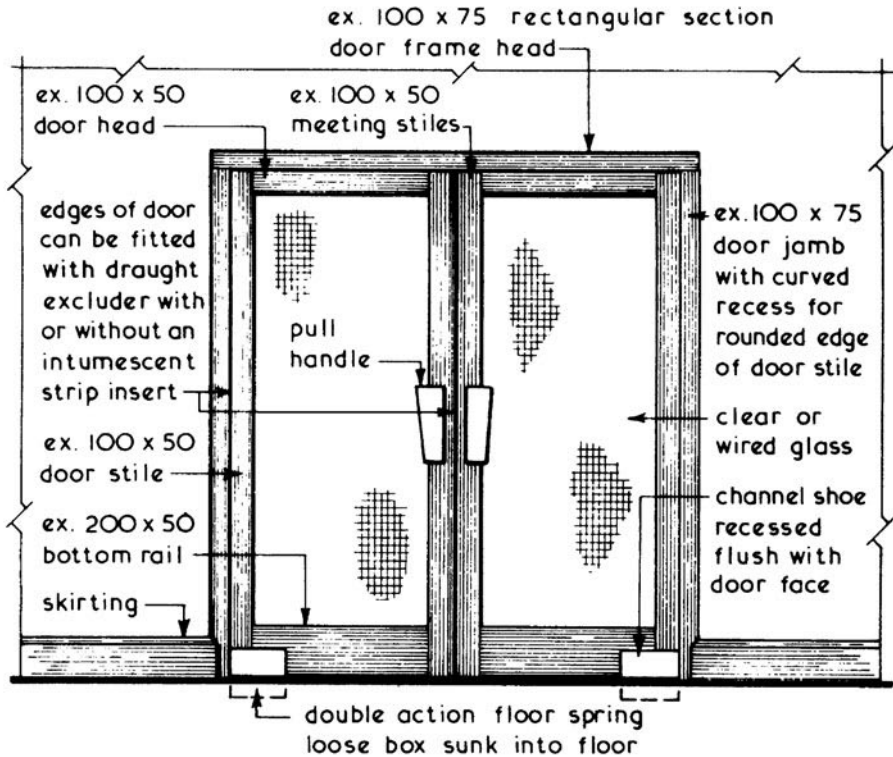

ELEVATION

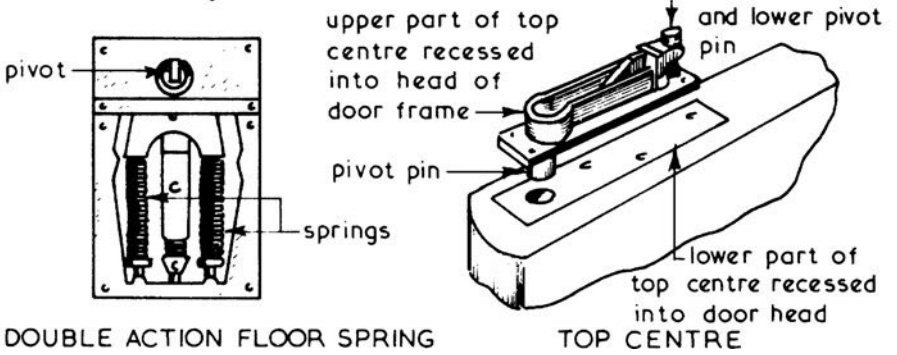
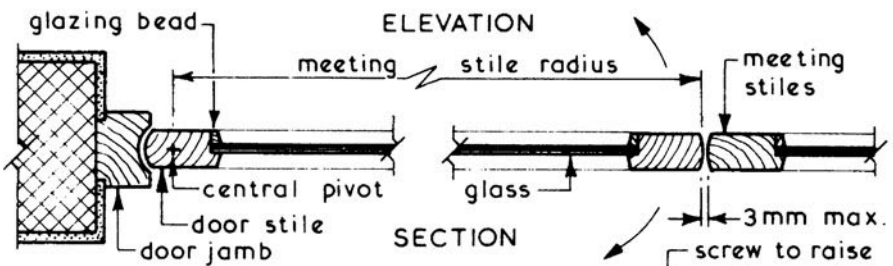



## Plasterboard Ceilings

Plasterboard ~ a rigid board composed of gypsum sandwiched between durable lining paper outer facings. For ceiling applications, the following types can be used:

Baseboard -

1220 × 900 × 9.5mm thick for joist centres up to 400mm.

1220 × 600 × 12.5mm thick for joist centres up to 600mm.

Baseboard has square edges and can be plaster skim finished. Joints are reinforced with self-adhesive 50mm min. width glass fibre mesh scrim tape or the board manufacturer's recommended paper tape. These boards are also made with a metallised polyester foil backing for vapour check applications. The foil is to prevent any moisture produced in potentially damp situations such as a bathroom or in warm roof construction from affecting loft insulation and timber. Joints should be sealed with an adhesive metallised tape.

Wallboard -

9.5, 12.5 and 15mm thicknesses, 900 and 1200mm widths and lengths of 1800 and 2400mm. Longer boards are produced in the two greater thicknesses and a vapour check variation is available. Edges are either tapered for taped and filled joints for dry lining or square for skimmed plaster or textured finishes.

Plasterboards should be fixed breaking joint to the underside of floor or ceiling joists with zinc plated (galvanised) nails or dry-wall screws at 150mm max. spacing. The junction at ceiling to wall is reinforced with glass fibre mesh scrim tape or a preformed plaster moulding.

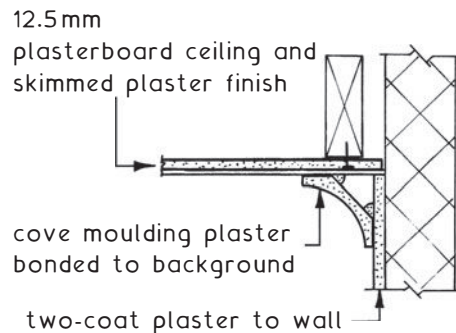
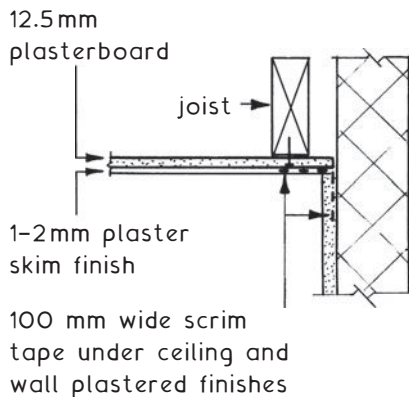

Alternative

Suspended Ceilings ~ these can be defined as ceilings which are fixed to a framework suspended from main structure, thus forming a void between the two components. The basic functional requirements of suspended ceilings are:

1. They should be easy to construct, repair, maintain and clean.
2. So designed that an adequate means of access is provided to the void space for the maintenance of the suspension system, concealed services and/or light fittings.
3. Provide any required sound and/or thermal insulation.
4. Provide any required acoustic control in terms of absorption and reverberation.
5. Provide if required structural fire protection to structural steel beams supporting a concrete floor and contain fire stop cavity barriers within the void at defined intervals.
6. Conform with the minimum requirements set out in the Building Regulations governing the restriction of spread of flame over surfaces of ceilings and the exemptions permitting the use of certain plastic materials.
7. Flexural design strength in varying humidity and temperature.
8. Resistance to impact.
9. Designed on a planning module, preferably a 300 mm dimensional coordinated system.

Typical Suspended Ceiling Grid Framework Layout ~

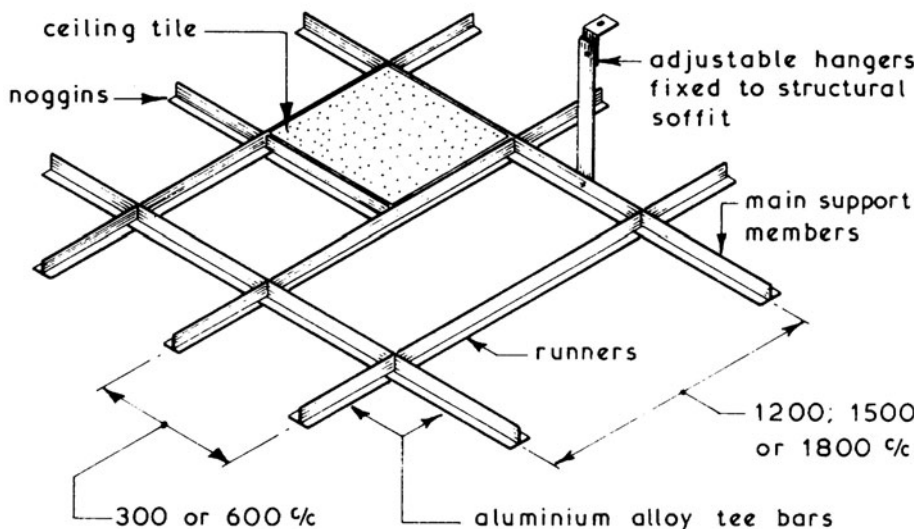

## Suspended Ceilings

Classification of Suspended Ceiling ~ there is no standard method of classification since some are classified by their function such as illuminated and acoustic suspended ceilings, others are classified by the materials used and classification by method of construction is also very popular. The latter method is simple, since most suspended ceiling types can be placed in one of three groups:

1. Jointless suspended ceilings.
2. Panelled suspended ceilings – see next page.
3. Decorative and open suspended ceilings – see page 848.

Jointless Suspended Ceilings ~ these forms of suspended ceilings provide a continuous and jointless surface with the internal appearance of a conventional ceiling. They may be selected to fulfil fire resistance requirements or to provide a robust form of suspended ceiling. The two common ways of construction are a plasterboard or expanded metal lathing soffit with hand-applied plaster finish or a sprayed applied rendering with a cement base.

Typical Details ~

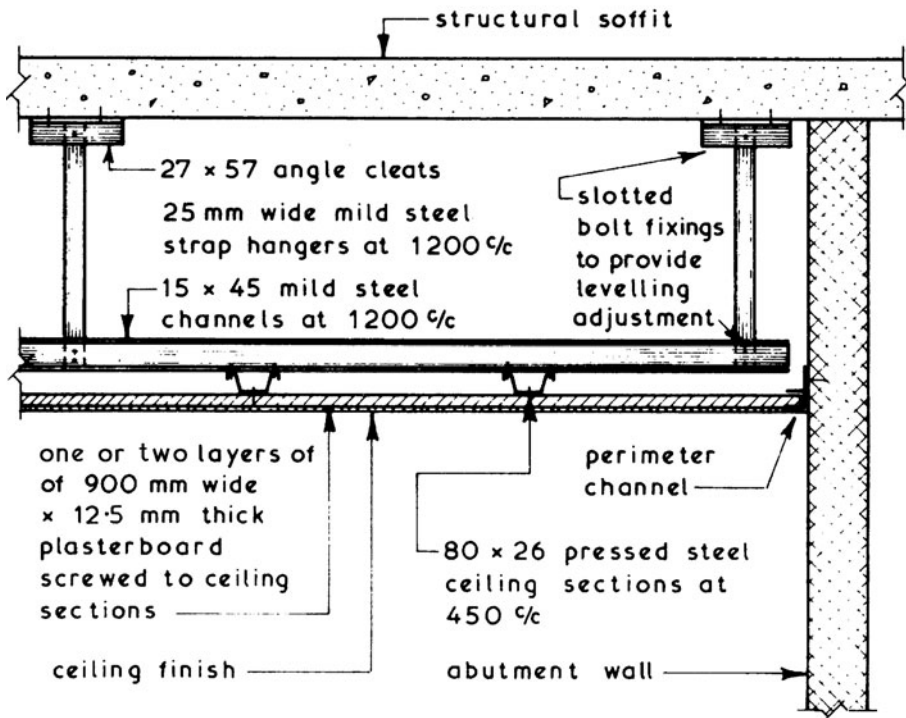

See also: BS EN 13964: Suspended ceilings. Requirements and test methods.

Panelled Suspended Ceilings ~ these are the most popular form of suspended ceiling consisting of a suspended grid framework to which the ceiling covering is attached. The covering can be of a tile, tray, board or strip format in a wide variety of materials with an exposed or concealed supporting framework. Services such as luminaries can usually be incorporated within the system. Generally panelled systems are easy to assemble and install using a water level or laser beam for initial and final levelling. Provision for maintenance access can be easily incorporated into most systems and layouts.

## Typical Support Details ~

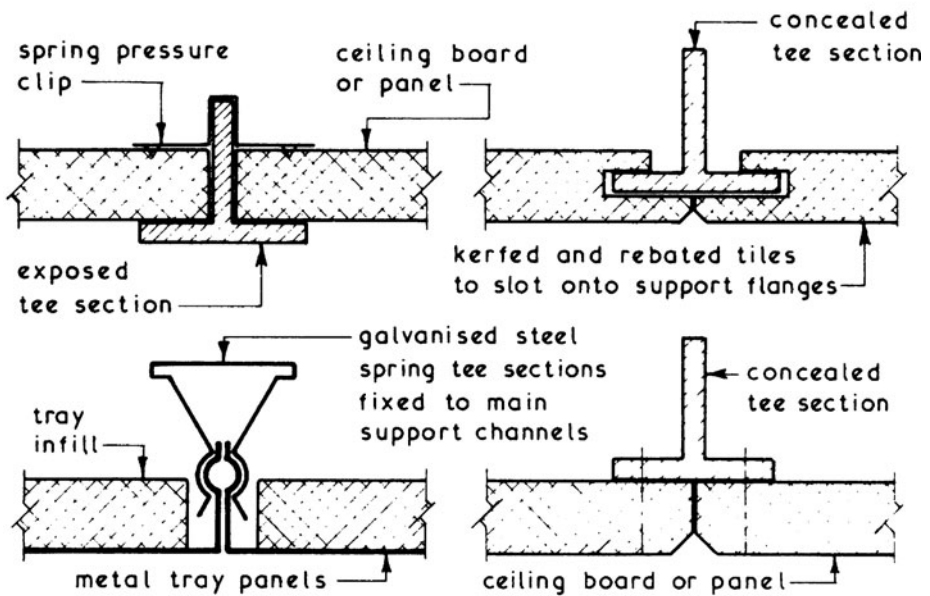

## Typical Panelled Suspended Ceiling Details ~

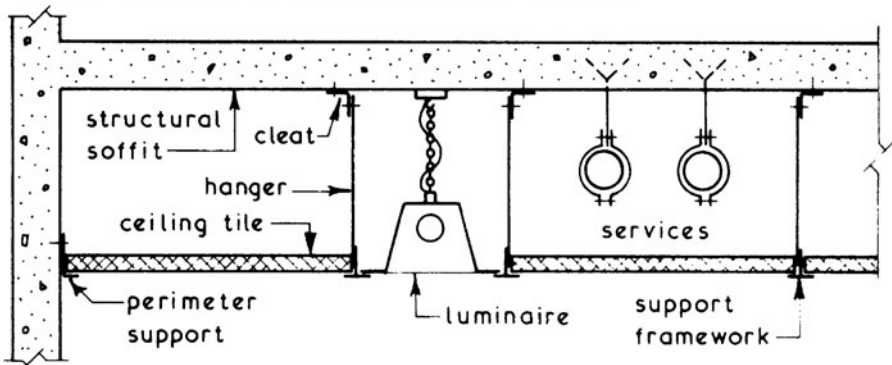

# Suspended Ceilings

Decorative and Open Suspended Ceilings ~ these ceilings usually consist of an openwork grid or suspended shapes onto which the lights fixed at, above or below ceiling level can be trained, thus creating a decorative and illuminated effect. Many of these ceilings are purpose designed and built as opposed to the proprietary systems associated with jointless and panelled suspended ceilings.

Typical Examples ~

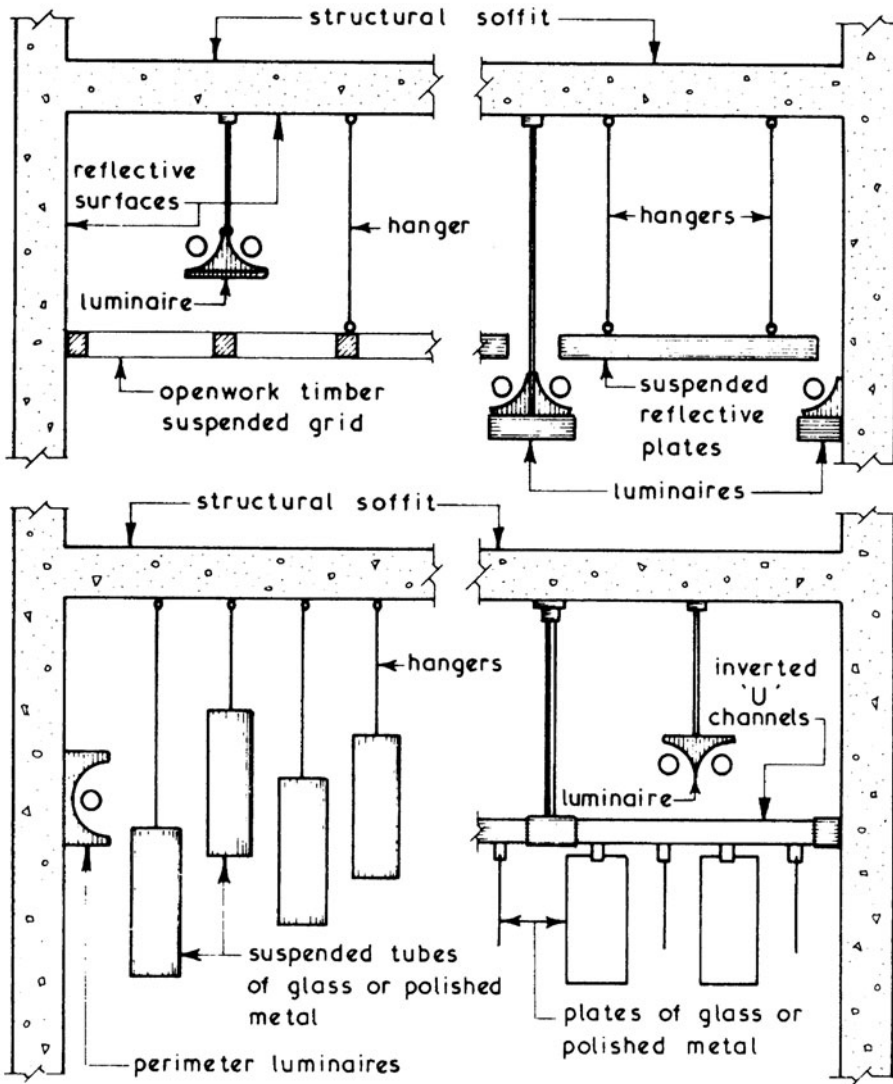

## Suspended Ceilings - Sound and Thermal Insulation

Separating floor construction for sound insulation purposes. References: Robust Details, see page 67 and Building Regulations, Approved Document E: Resistance to the passage of sound.

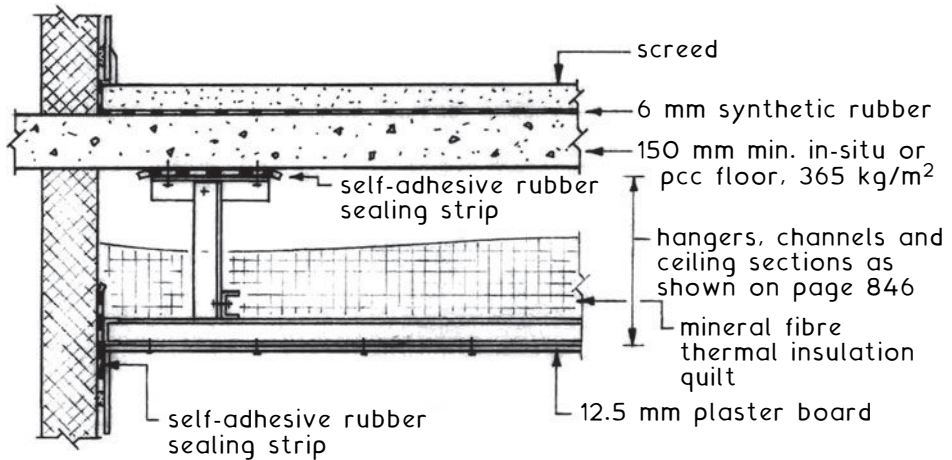

Alternative Finish with Floating Deck ~

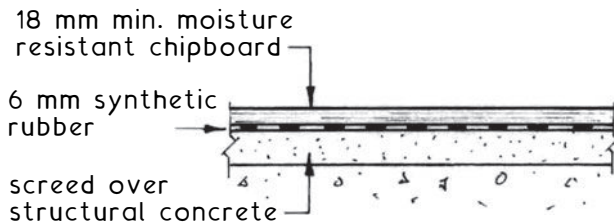

Further Building Regulations References ~

Approved Document B: Fire safety, Volumes 1 and 2 - Fire resisting cavity barriers in concealed spaces. Located at compartmented divisions within a building (see page 18), otherwise at a maximum spacing that will depend on the situation, building type and its function. Minimum fire resistance is 30 minutes but often more depending on the building use and purpose.

Approved Document L: Conservation of fuel and power - thermal insulation requirements.

## Paints and Painting

Functions ~ the main functions of paint are to provide:

1. An economical method of surface protection to building materials and components.
2. An economical method of surface decoration to building materials and components.

Composition ~ the actual composition of any paint can be complex but the basic components are:

1. Binder ~ this is the liquid vehicle or medium which dries to form the surface film and can be composed of linseed oil, drying oils, synthetic resins or water. The first function of a paint medium is to provide a means of spreading the paint over the surface and at the same time acting as a binder to the pigment.
2. Pigment ~ this provides the body, colour, durability, opacity and corrosion protection properties of the paint. The general pigment used in paint is titanium dioxide which gives good obliteration of the undercoats. Other pigments include carbon black and iron oxide.
3. Solvents and Thinners ~ these are materials which can be added to a paint to alter its viscosity. This increases workability and penetration. Water is used for emulsion paint and white spirit or turpentine for oil paint.
4. Drier ~ accelerates drying by absorbing oxygen from the air and converting by oxidation to a solid. Soluble metals in linseed oil or white spirit.

Paint Types - there is a wide range available but for most general uses the following can be considered:

1. Oil-based Paints - these are available in priming, undercoat and finishing grades. The latter can be obtained in a wide range of colours and finishes such as matt, semi-matt, eggshell, satin, gloss and enamel. Polyurethane paints have a good hardness and resistance to water and cleaning. Oil-based paints are suitable for most applications if used in conjunction with correct primer and undercoat.
2. Water-based Paints - most of these are called emulsion paints, the various finishes available being obtained by adding to the water medium additives such as alkyd resin and polyvinyl acetate (PVA). Finishes include matt, eggshell, semi-gloss and gloss. Emulsion paints are easily applied, quick drying and can be obtained with a washable finish and are suitable for most applications.

Supply ~ paint is usually supplied in metal containers ranging from 250 millilitres to 5 litres capacity to the colour ranges recommended in BS 381C (colours for specific purposes) and BS 4800 (paint colours for building purposes).

Application ~ paint can be applied to almost any surface providing the surface preparation and sequence of paint coats are suitable. The manufacturer's specification and/or the recommendations of BS 6150 (painting of buildings) should be followed. Preparation of the surface to receive the paint is of the utmost importance, since poor preparation is one of the chief causes of paint failure. The preparation consists basically of removing all dirt, grease, dust and ensuring that the surface will provide an adequate key for the paint which is to be applied. In new work the basic buildup of paint coats consists of:

1. Priming Coats - these are used on unpainted surfaces to obtain the necessary adhesion and to inhibit corrosion of ferrous metals. New timber should have the knots treated with a solution of shellac or other alcohol-based resin called knotting prior to the application of the primer.
2. Undercoats - these are used on top of the primer after any defects have been made good with a suitable stopper or filler. The primary function of an undercoat is to give the opacity and buildup necessary for the application of the finishing coat(s).
3. Finish - applied directly over the undercoating in one or more coats to impart the required colour and finish.

Paint can applied by:

1. Brush - the correct type, size and quality of brush such as those recommended in BS 2992 (painters' and decorators' brushes) needs to be selected and used. To achieve a first class finish by means of brush application requires a high degree of skill.
2. Spray - as with brush application a high degree of skill is required to achieve a good finish. Generally compressed air sprays or airless sprays are used for building works.
3. Roller - simple and inexpensive method of quickly and cleanly applying a wide range of paints to flat and textured surfaces. Roller heads vary in size from 50 to 450 mm wide with various covers such as sheepskin, synthetic pile fibres, mohair and foamed polystyrene. All paint applicators must be thoroughly cleaned after use.



## Painting – Preparation

Painting ~ the main objectives of applying coats of paint to a surface are preservation, protection and decoration to give a finish which is easy to clean and maintain. To achieve these objectives the surface preparation and paint application must be adequate. The preparation of new and previously painted surfaces should ensure that prior to painting the surface is smooth, clean, dry and stable.

### Basic Surface Preparation Techniques ~

Timber - to ensure a good adhesion of the paint film all timber should have a moisture content of less than 18%. The timber surface should be prepared using an abrasive paper to produce a smooth surface brushed and wiped free of dust and any grease removed with a suitable spirit. Careful treatment of knots is essential either by sealing with two coats of knotting or in extreme cases cutting out the knot and replacing with sound timber. The stopping and filling of cracks and fixing holes with putty or an appropriate filler should be carried out after the application of the priming coat. Each coat of paint must be allowed to dry hard and be rubbed down with a fine abrasive paper before applying the next coat. On previously painted surfaces if the paint is in a reasonable condition the surface will only require cleaning and rubbing down before repainting; when the paint is in a poor condition it will be necessary to remove completely the layers of paint and then prepare the surface as described above for new timber.

Building Boards - most of these boards require no special preparation except for the application of a sealer as specified by the manufacturer.

Iron and Steel - good preparation is the key to painting iron and steel successfully and this will include removing all rust, mill scale, oil, grease and wax. This can be achieved by wire brushing, using mechanical means such as shot blasting, flame cleaning and chemical processes and any of these processes are often carried out in the steel fabrication works prior to shop-applied priming.

Plaster - the essential requirement of the preparation is to ensure that the plaster surface is perfectly dry, smooth and free of defects before applying any coats of paint, especially when using gloss paints. Plaster which contains lime can be alkaline and such surfaces should be treated with an alkali-resistant primer when the surface is dry before applying the final coats of paint.

Paint Defects ~ these may be due to poor or incorrect preparation of the surface, poor application of the paint and/or chemical reactions. The general remedy is to remove all the affected paint and carry out the correct preparation of the surface before applying new coats of paint in the correct manner. Most paint defects are visual and therefore an accurate diagnosis of the cause must be established before any remedial treatment is undertaken.

Typical paint defects:

1. Bleeding – staining and disruption of the paint surface by chemical action, usually caused by applying an incorrect paint over another. Remedy is to remove affected paint surface and repaint with correct type of overcoat paint.
2. Blistering – usually caused by poor presentation allowing resin or moisture to be entrapped, the subsequent expansion causing the defect. Remedy is to remove all the coats of paint and ensure that the surface is dry before repainting.
3. Blooming – mistiness usually on high gloss or varnished surfaces due to the presence of moisture during application. It can be avoided by not painting under these conditions. Remedy is to remove affected paint and repaint.
4. Chalking – powdering of the paint surface due to natural ageing or the use of poor-quality paint. Remedy is to remove paint if necessary, prepare surface and repaint.
5. Cracking and Crazing – usually due to unequal elasticity of successive coats of paint. Remedy is to remove affected paint and repaint with compatible coats of paint.
6. Flaking and Peeling – can be due to poor adhesion, presence of moisture, painting over unclean areas or poor preparation. Remedy is to remove defective paint, prepare surface and repaint.
7. Grinning – due to poor opacity of paint film allowing paint coat below or background to show through, could be the result of poor application, incorrect thinning or the use of the wrong colour. Remedy is to apply further coats of paint to obtain a satisfactory surface.
8. Saponification – formation of soap from alkali present in or on surface painted. The paint is ultimately destroyed and a brown liquid appears on the surface. Remedy is to remove the paint films and seal the alkaline surface before repainting.

## Joinery Production - Machinery

Joinery Production ~ this can vary from the flow production where one product such as flush doors is being made usually with the aid of purpose-designed and built machines, to batch production where a limited number of similar items are being made with the aid of conventional woodworking machines. Purpose-made joinery is very often largely handmade with a limited use of machines and is considered when special and/or high-class joinery components are required.

Woodworking Machines ~ except for the portable electric tools such as drills, routers, jigsaws and sanders most woodworking machines need to be fixed to a solid base and connected to an extractor system to extract and collect the sawdust and chippings produced by the machines.

Saws - basically three formats are available, namely the circular, cross-cut and band saws. Circular saws are general-purpose saws and usually have tungsten carbide tipped teeth with feed rates of up to 60 000 per minute. Cross-cut saws usually have a long bench to support the timber, the saw being mounted on a radial arm enabling the circular saw to be drawn across the timber to be cut. Band saws consist of an endless thin band or blade with saw teeth and a table on which to support the timber and are generally used for curved work.

Planers - most of these machines are combined planers and thicknessers, the timber being passed over the table surface for planing and the table or bed for thicknessing. The planer has a guide fence which can be tilted for angle planing and usually the rear bed can be lowered for rebating operations. The same rotating cutter block is used for all operations. Planing speeds are dependent upon the operator since it is a hand-fed operation whereas thicknessing is mechanically fed with a feed speed range of 6 000 to 20 000 per minute. Maximum planing depth is usually 10 mm per passing.

Morticing Machines - these are used to cut mortices up to 25 mm wide and can be either a chisel or chain morticer. The former consists of a hollow chisel containing a bit or auger whereas the latter has an endless chain cutter.

Tenoning Machines - these machines with their rotary cutter blocks can be set to form tenon and scribe. In most cases they can also be set for trenching, grooving and cross-cutting.

Spindle Moulder - this machine has a horizontally rotating cutter block into which standard or purpose-made cutters are fixed to reproduce a moulding on timber passed across the cutter.

Purpose-made Joinery ~ joinery items in the form of doors, windows, stairs and cupboard fitments can be purchased as stock items from manufacturers. There is also a need for purpose-made joinery to fulfil client/designer/user requirements to suit a specific need, to fit into a non-standard space, as a specific decor requirement or to complement a particular internal environment. These purpose-made joinery items can range from the simple to the complex which require high degrees of workshop and site skills.

Typical Purpose-made Counter Details ~

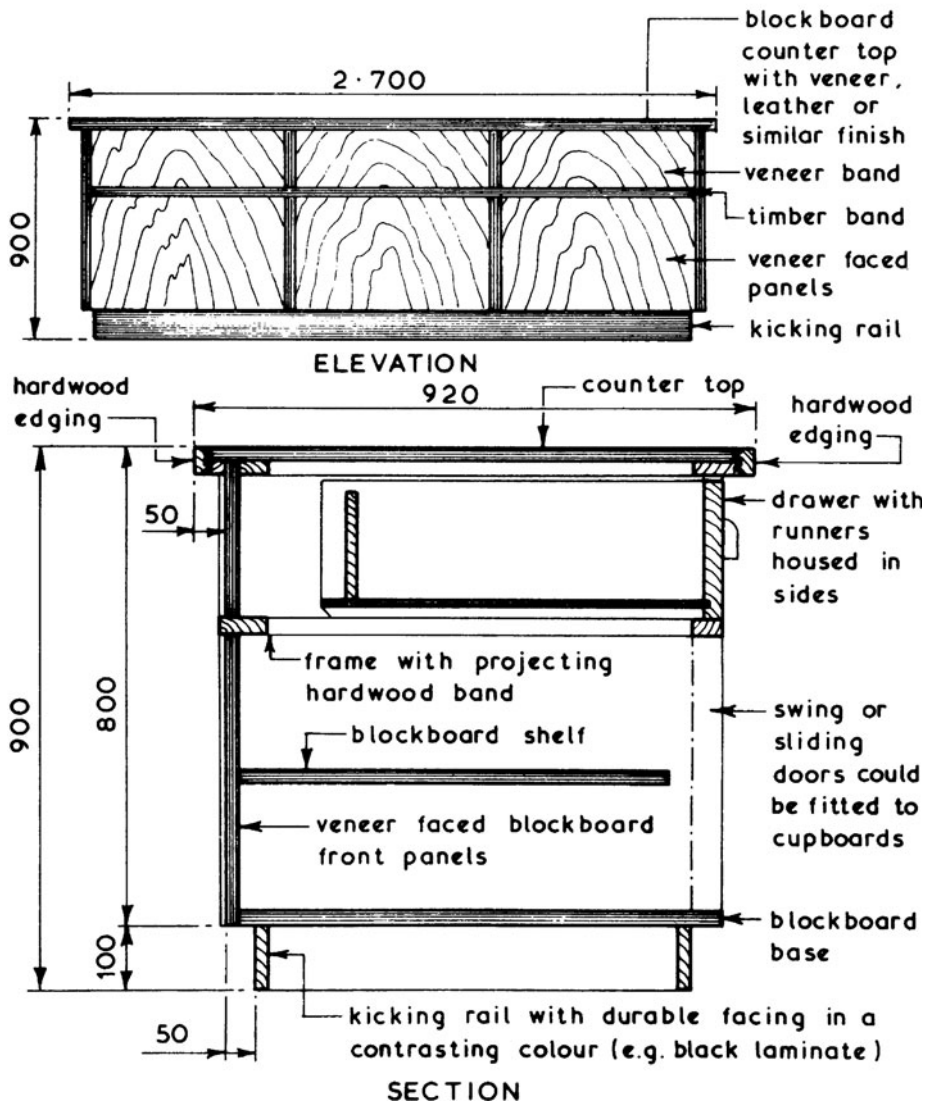

Typical Purpose-made Wall Panelling Details ~

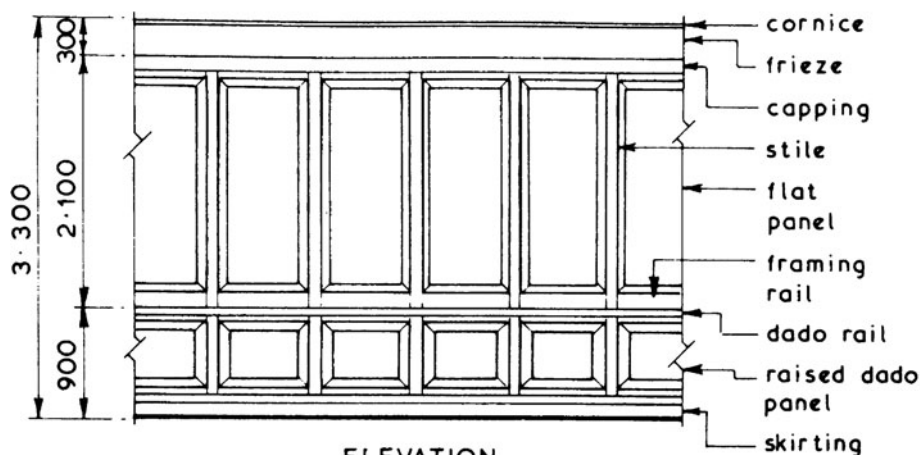

ELEVATION

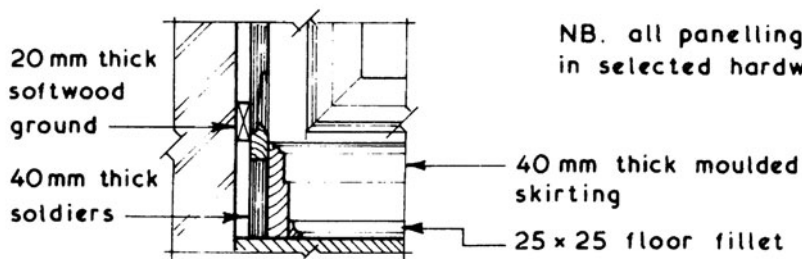
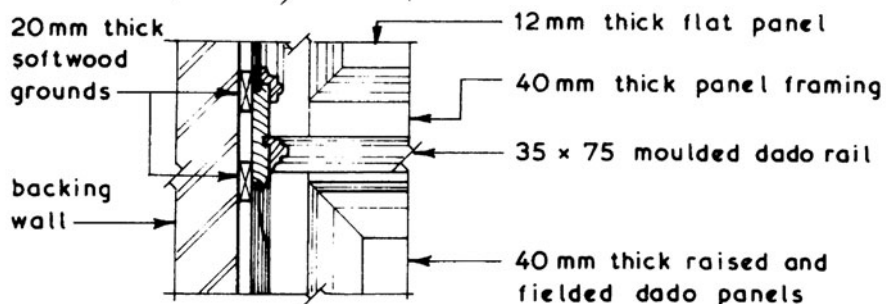
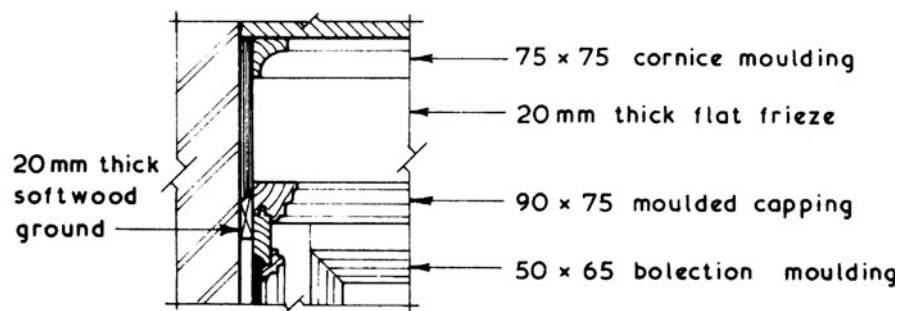

NB. all panelling to be in selected hardwoods.

SECTION

Standard Finishings and Trimmings ~

Architraves



Torus



Rebated



Ogee



Ovolo



Chamfered



Bullnose

Picture rails



Profile names vary between manufacturers

Dado rails



Profile names vary between manufacturers

Skirtings



Bullnose



Chamfered



Torus



Ogee



Classic

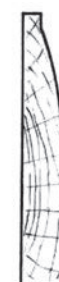

Ovolo

## Joinery Production –Softwood Timbers

Joinery Timbers ~ both hardwoods and softwoods can be used for joinery works. Softwoods can be selected for their stability, durability and/or workability if the finish is to be paint but if it is left in its natural colour with a sealing coat the grain texture and appearance should be taken into consideration. Hardwoods are usually left in their natural colour and treated with a protective clear sealer or polish; therefore texture, colour and grain pattern are important when selecting hardwoods for high-class joinery work.

Typical softwoods suitable for joinery work:

1. Douglas Fir – sometimes referred to as Columbian Pine or Oregon Pine. It is available in long lengths and has a straight grain. Colour is reddish-brown to pink. Suitable for general and high-class joinery. Approximate density 530 kg/m<sup>3</sup>.
2. Redwood – also known as Scots Pine, Red Pine, Red Deal and Yellow Deal. It is a widely used softwood for general joinery work having good durability, a straight grain and is reddish-brown to straw in colour. Approximate density 430 kg/m<sup>3</sup>.
3. European Spruce – similar to redwood but with a lower durability. It is pale yellow to pinkish-white in colour and is used mainly for basic framing work and simple internal joinery. Approximate density 650 kg/m<sup>3</sup>.
4. Sitka Spruce – originates from Alaska, Western Canada and Northwest USA. The long, white strong fibres provide a timber quality for use in board or plywood panels. Approximate density 450 kg/m<sup>3</sup>.
5. Pitch Pine – durable softwood suitable for general joinery work. It is light red to reddish-yellow in colour and tends to have large knots which in some cases can be used as a decorative effect. Approximate density 650 kg/m<sup>3</sup>.
6. Parana Pine – moderately durable straight grained timber available in a good range of sizes. Suitable for general joinery work especially timber stairs. Light to dark brown in colour with the occasional pink stripe. Approximate density 560 kg/m<sup>3</sup>.
7. Western Hemlock – durable softwood suitable for interior joinery work such as panelling. Light yellow to reddish-brown in colour. Approximate density 500 kg/m<sup>3</sup>.
8. Western Red Cedar – originates from British Columbia and Western USA. A straight grained timber suitable for flush doors and panel work. Approximate density 380kg/m<sup>3</sup>.

Typical hardwoods suitable for joinery works:

1. Beech – hard close grained timber with some silver grain in the predominately reddish-yellow to light brown colour. Suitable for all internal joinery. Approximately density 700 kg/m<sup>3</sup>.
2. Iroko – hard durable hardwood with a figured grain and is usually golden brown in colour. Suitable for all forms of high-class joinery. Approximate density 660 kg/m<sup>3</sup>.
3. Mahogany (African) – interlocking grained hardwood with good durability. It has an attractive light brown to deep red colour and is suitable for panelling and all high-class joinery work. Approximate density 560 kg/m<sup>3</sup>.
4. Mahogany (Honduras) – durable hardwood usually straight grained but can have a mottled or swirl pattern. It is light red to pale reddish-brown in colour and is suitable for all high-class joinery work. Approximate density 530 kg/m<sup>3</sup>.
5. Mahogany (South American) – a well-figured, stable and durable hardwood with a deep-red or brown colour which is suitable for all high-class joinery particularly where a high polish is required. Approximate density 550 kg/m<sup>3</sup>.
6. Oak (English) – very durable hardwood with a wide variety of grain patterns. It is usually a light yellow brown to a warm brown in colour and is suitable for all forms of joinery but should not be used in conjunction with ferrous metals due to the risk of staining caused by an interaction of the two materials. (The gallic acid in oak causes corrosion in ferrous metals.) Approximate density 720 kg/m<sup>3</sup>.
7. Sapele – close texture timber of good durability, dark reddish-brown in colour with a varied grain pattern. It is suitable for most internal joinery work especially where a polished finish is required. Approximate density 640 kg/m<sup>3</sup>.
8. Teak – very strong and durable timber but hard to work. It is light golden brown to dark golden yellow in colour which darkens with age and is suitable for high-class joinery work and laboratory fittings. Approximate density 650 kg/m<sup>3</sup>.
9. Jarrah (Western Australia) – hard, dense, straight grained timber. Dull red colour, suited to floor and stair construction subjected to heavy wear. Approximate density 820 kg/m<sup>3</sup>.



## Composite Boarding and Sheet Materials

Composite Boards ~ factory-manufactured, performed sheets with a wide range of properties and applications. The most common size is 2440 × 1220 mm or 2400 × 1200 mm in thicknesses from 3 to 50 mm.

1. Plywood (BS EN 636) - produced in a range of laminated thicknesses from 3 to 25 mm, with the grain of each layer normally at right angles to that adjacent. 3, 7, 9 or 11 plies make up the overall thickness and inner layers may have lower strength and different dimensions to those in the outer layers. Adhesives vary considerably from natural vegetable and animal glues to synthetics such as urea, melamine, phenol and resorcinol formaldehydes. Quality of laminates and type of adhesive determine application. Surface finishes include plastics, decorative hardwood veneers, metals, rubber and mineral aggregates.
2. Block and Stripboards (BS EN 12871) - range from 12 to 43 mm thickness, made up from a solid core of glued softwood strips with a surface-enhancing veneer. Appropriate for dense panelling and doors.

Battenboard - strips over 30 mm wide (unsuitable for joinery).

Blockboard - strips up to 25 mm wide.

Laminboard - strips up to 7 mm wide.

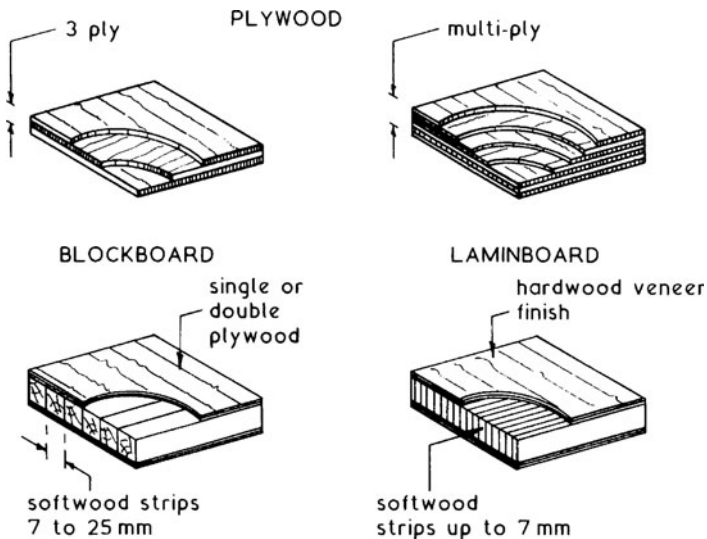

3. Compressed Strawboard (BS 4046) - produced by compacting straw under heat and pressure, and edge binding with paper. Used as panels with direct decoration or as partitioning with framed support. Also for insulated roof decking with 58 mm slabs spanning 600 mm joist spacing.

### 4. Particle Board

Chipboard (BS EN 319) - bonded waste wood or chip particles in thicknesses from 6 to 50 mm, popularly used for floors in 18 and 22 mm at 450 and 600 mm maximum joist spacing, respectively. Sheets are produced by heat pressing the particles in thermosetting resins.

Wood Cement Board - approximately 25% wood particles mixed with water and cement, to produce a heavy and dense board often preferred to plasterboard and fibre cement for fire cladding. Often three-layer boards, from 6 to 40 mm in thickness.

Oriented Strand Board (BS EN 300) - composed of wafer thin strands of wood, approximately 80 mm long × 25 mm wide, resin bonded and directionally oriented before superimposed by further layers. Each layer is at right angles to adjacent layers, similar to the structure of plywood. A popular alternative for wall panels, floors and other chipboard and plywood applications, they are produced in a range of thicknesses from 6 to 25 mm.

5. Fibreboards (BS EN 622-4) - basically wood in composition, reduced to a pulp and pressed to achieve three categories:

Hardboard density at least 800 kg/m<sup>3</sup> in thicknesses from 3.2 to 8 mm. Provides an excellent base for coatings and laminated finishes.

Mediumboard (low density) 350 to 560 kg/m<sup>3</sup> for pinboards and wall linings in thicknesses of 6.4, 9, and 12.7 mm.

Mediumboard (high density) 560 to 800 kg/m<sup>3</sup> for linings and partitions in thicknesses of 9 and 12 mm.

Softboard, otherwise known as insulating board with density usually below 250 kg/m<sup>3</sup>. Thicknesses from 9 to 25 mm, often found impregnated with bitumen in existing flat roofing applications. Ideal as pinboard.

Medium Density Fibreboard, differs from other fibreboards with the addition of resin bonding agent. These boards have a very smooth surface, ideal for painting, and are available moulded for a variety of joinery applications. Density exceeds 600 kg/m<sup>3</sup> and common board thicknesses are 9, 12, 18 and 25 mm for internal and external applications.

6. Woodwool (BS EN 13168) - units of 600 mm width are available in 50, 75 and 100 mm thicknesses. They comprise long wood shavings coated with a cement slurry, compressed to leave a high proportion of voids. These voids provide good thermal insulation and sound absorption. The perforated surface is an ideal key for direct plastering and they are frequently specified as permanent formwork.

## Plastics in Building

Plastics ~ the term plastic can be applied to any group of substances based on synthetic or modified natural polymers which during manufacture are moulded by heat and/or pressure into the required form. Plastics can be classified by their overall grouping such as polyvinyl chloride (PVC) or they can be classified as thermoplastic or thermosetting. The former soften on heating whereas the latter are formed into permanent non-softening materials. The range of plastics available give the designer and builder a group of materials which are strong, reasonably durable, easy to fit and maintain and since most are mass produced of relative low cost.

Typical Applications of Plastics in Buildings ~

Application	Plastics used
Rainwater goods	unplasticised PVC (uPVC or PVC-U).
Soil, waste, water and gas pipes and fittings	uPVC; polyethylene (PE); acrylonitrile butadiene styrene (ABS), polypropylene (PP).
Hot and cold water pipes	chlorinated PVC; ABS; polypropylene; polyethylene; PVC (not for hot water).
Bathroom and kitchen fittings	glass-fibre reinforced polyester (GRP); acrylic resins.
Cold water cisterns	polypropylene; polystyrene; polyethylene.
Rooflights and sheets	GRP; acrylic resins; uPVC.
DPCs and membranes, vapour control layers	low-density polyethylene (LDPE); PVC film; polypropylene.
Doors and windows	GRP; uPVC.
Electrical conduit and fittings	plasticised PVC; uPVC; phenolic resins.
Thermal insulation	generally cellular plastics such as expanded polystyrene bead and boards; expanded PVC; foamed polyurethane; foamed phenol formaldehyde; foamed urea formaldehyde.
Floor finishes	plasticised PVC tiles and sheets; resin-based floor paints; uPVC.
Wall claddings and internal linings	unplasticised PVC; polyvinyl fluoride film laminate; melamine resins; expanded polystyrene tiles and sheets.

Uses ~ to weather- and leak-proof junctions and abutments between separate elements and components that may be subject to differential movement. Also to gap fill where irregularities occur.

Properties:

- thermal movement to facilitate expansion and contraction
- strength to resist wind and other non-structural loading
- ability to accommodate tolerance variations
- stability without loss of shape
- colour fast and non-staining to adjacent finishes
- weather resistant

Maintenance ~ of limited life, perhaps 10 to 25 years depending on composition, application and use. Future accessibility is important for ease of removal and replacement.

Mastics ~ generally regarded as non-setting gap fillers applied in a plastic state. Characterised by a hard surface skin over a plastic core that remains pliable for several years. Based on a viscous material such as bitumen, polyisobutylene or butyl rubber. Applications include bitumen treatment to rigid road construction joints (page 167) and linseed oil putty glazing (page 449). In older construction, a putty-based joint may also be found between WC pan spigot outlet and cast iron socket. In this situation the putty was mixed with red lead pigments (oxides of lead), a material now considered a hazardous poison, therefore protective care must be taken when handling an old installation of this type. Modern push-fit plastic joints are much simpler, safer to use and easier to apply.

Sealants ~ applied in a plastic state by hand, knife, disposable cartridge gun, pouring or tape strip to convert by chemical reaction with the atmosphere (one part) or with a vulcanising additive (two part) into an elastomer or synthetic rubber. An elastomer is generally defined as a natural or synthetic material with a high strain capacity or elastic recovery, i.e. it can be stretched to twice its length before returning to its original length.

## Sealants

Formed of polysulphide rubber, polyurethane, silicone or some butyl rubbers.

Applications:

- Polysulphide ~ façades, glazing, fire protection, roads and paving joints. High modulus or hardness but not completely elastic.
- Polyurethane ~ general uses, façades and civil engineering. Highly elastic and resilient to abrasion and indentation, moderate resistance to ultraviolet light and chemicals.
- Silicone ~ general uses, façades, glazing, sanitary, fire protection and civil engineering. Mainly one part but set quickly relative to others in this category. Highly elastic and available as high (hard) or low (soft) modulus.

Two part ~ polysulphide- and polyurethane-based sealants are often used with a curing or vulcanising additive to form a synthetic rubber on setting. After the two parts are mixed the resulting sealant remains workable for up to about four hours. It remains plastic for a few days and during this time cannot take any significant loading. Thereafter it has exceptional resistance to compression and shear.

One part ~ otherwise known as room temperature vulcanising (RTV) types that are usually of a polysulphide, polyurethane or silicone base. Polysulphide and polyurethane cure slowly and convert to a synthetic rubber or elastomer sealant by chemical reaction with moisture in the atmosphere. Generally of less movement and loading resistance to two part sealants, but are frequently used in non-structural situations such as sealing around door and window frames, bathroom and kitchen fitments.

Other sealants:

- One part acrylic (water-based) RTV. Flexible but with limited elasticity. Internal uses such as sealing around door and window frames, fire protection and internal glazing.
- Silane modified polymer in one part RTV or two parts. Highly elastic and can be used for general applications as well as for façades and civil engineering situations.

Prior to 2003, several separate British Standards existed to provide use and application guidance for a range of sealant products. As independent publications these are now largely superseded, their content rationalised and incorporated into the current standard, BS EN ISO 11600: Building construction. Jointing products. Classification and requirements for sealants.

This International Standard covers materials application to jointing, classification of materials, quality grading and performance testing. This enables specific definition of a sealant's requirements in terms of end use without having to understand the chemical properties of the various sealant types. Typical criteria are movement potential, elasticity and hardness when related to particular substrate surfaces such as aluminium, glass or masonry.

Grading summary ~

BS EN ISO 11600 G, for use in glazing.

BS EN ISO 11600 F, for façade and similar applications such as movement joints.

Other suffixes or sub-classes ~

E = elastic sealant, i.e. high elastic recovery or elastomeric.

P = plastic sealant, i.e. low elastic recovery.

HM = high modulus, indicates hardness.\*

LM = low modulus, indicates softness.\*

\*By definition HM and LM are high movement (20–25%) types of elastic sealants, therefore the suffix E is not shown with these.

Associated standards ~

BS EN ISO 6927: Buildings and civil engineering works. Sealants. Vocabulary.

BS 6213: Selection of construction sealants. Guide.

BS 6093: Design of joints and jointing in building construction. Guide.

*This page intentionally left blank*

## 8 DOMESTIC SERVICES

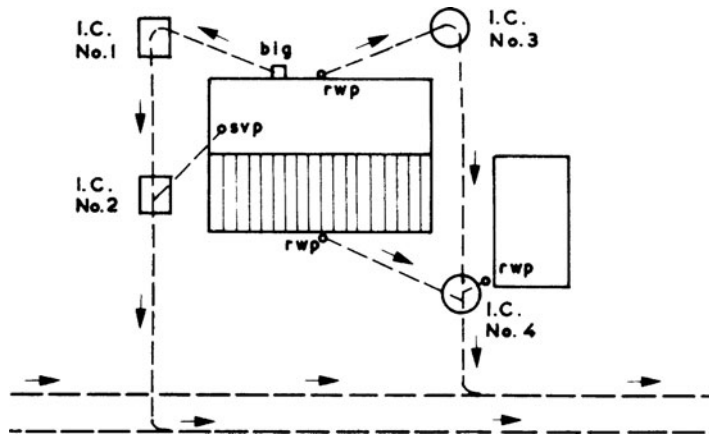

DRAINAGE EFFLUENTS  
SUBSOIL DRAINAGE  
SURFACE WATER REMOVAL  
ROAD DRAINAGE  
RAINWATER INSTALLATIONS  
DRAINAGE SYSTEMS  
DRAINAGE PIPE SIZES AND GRADIENTS  
WATER SUPPLY  
COLD WATER INSTALLATIONS  
HOT WATER INSTALLATIONS  
CISTERNS AND CYLINDERS  
SANITARY FITTINGS  
SINGLE AND VENTILATED STACK SYSTEMS  
DOMESTIC HOT WATER HEATING SYSTEMS  
ELECTRICAL SUPPLY AND INSTALLATION  
GAS SUPPLY AND GAS FIRES  
OPEN FIREPLACES AND FLUES  
SERVICES - FIRE STOPS AND SEALS  
TELEPHONE AND ELECTRONIC COMMUNICATIONS  
INSTALLATIONS



## Drainage Effluents

Effluent ~ can be defined as that which flows out. In building drainage terms there are three main forms of effluent:

1. Subsoil Water ~ water collected by means of special drains from the earth primarily to lower the water table level in the subsoil. It is considered to be clean and therefore requires no treatment and can be discharged direct into an approved water course.
2. Surface Water ~ effluent collected from surfaces such as roofs and paved areas and like subsoil water is considered to be clean and can be discharged direct into an approved water course or soakaway ~

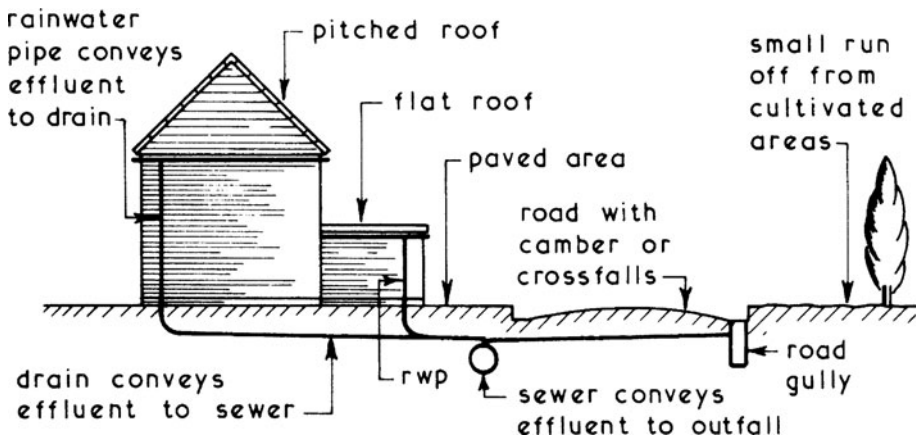

3. Foul or Soil Water ~ effluent contaminated by domestic or trade waste and will require treatment to render it clean before it can be discharged into an approved water course.

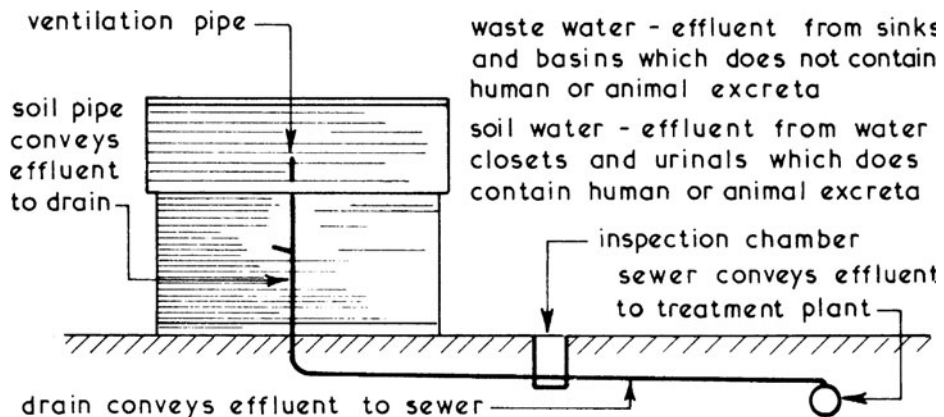

Subsoil Drainage ~ Building Regulation C2 requires that subsoil drainage shall be provided if it is needed to avoid:

- (a) the passage of ground moisture into the interior of the building or
- (b) damage to the fabric of the building.

Subsoil drainage can also be used to improve the stability of the ground, lower the humidity of the site and enhance its horticultural properties. Subsoil drains consist of porous or perforated pipes laid dry jointed in a rubble-filled trench. Porous pipes allow the subsoil water to pass through the body of the pipe whereas perforated pipes which have a series of holes in the lower half allow the subsoil water to rise into the pipe. This form of ground water control is only economical up to a depth of 1.500. If the water table needs to be lowered to a greater depth other methods of ground water control should be considered (see pages 354 to 358).

The water collected by a subsoil drainage system has to be conveyed to a suitable outfall such as a river, lake or surface water drain or sewer. In all cases permission to discharge the subsoil water will be required from the authority or owner and in the case of streams, rivers and lakes, bank protection at the outfall may be required to prevent erosion (see next page).

#### Typical Subsoil Drain Details ~

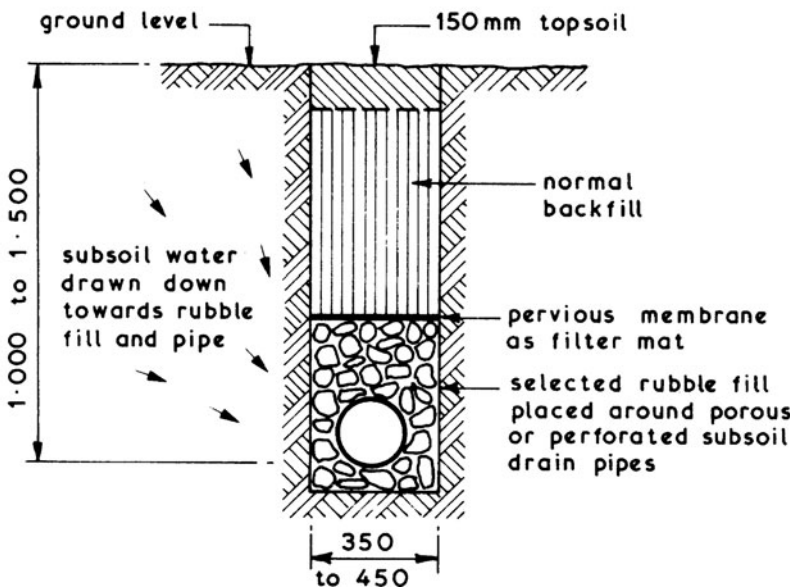

# Subsoil Drainage

Subsoil Drainage Systems ~ the layout of subsoil drains will depend on whether it is necessary to drain the whole site or if it is only the substructure of the building which needs to be protected. The latter is carried out by installing a cut off drain around the substructure to intercept the flow of water and divert it away from the site of the building. Junctions in a subsoil drainage system can be made using standard fittings or by placing the end of the branch drain onto the crown of the main drain.

## Typical Examples ~

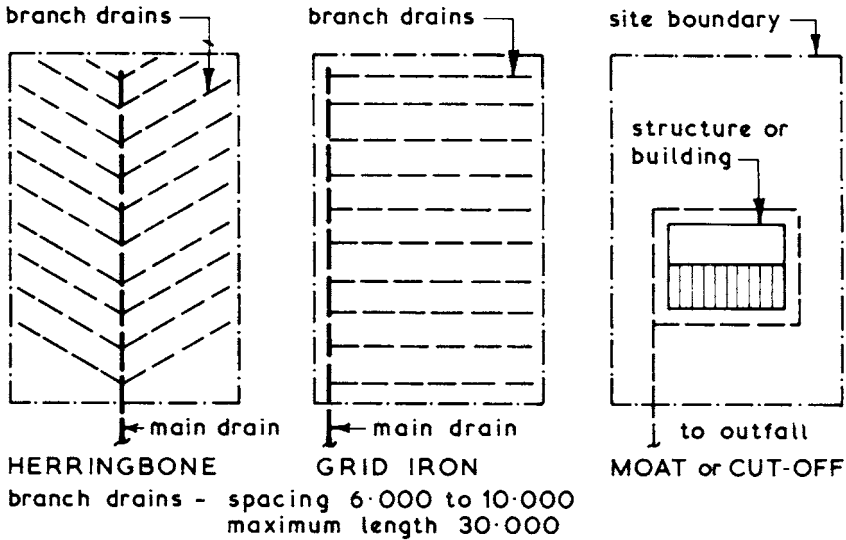

## TYPICAL OUTFALL DETAILS ~

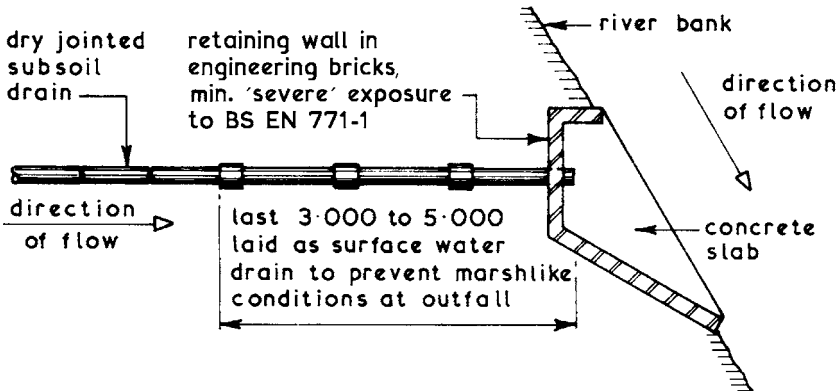

NB. Connections to surface water sewer can be made at inspection chamber or direct to the sewer using a saddle connector - it may be necessary to have a catchpit to trap any silt (see page 876).

General Principles ~ a roof must be designed with a suitable fall towards the surface water collection channel or gutter which in turn is connected to vertical rainwater pipes which convey the collected discharge to the drainage system. The fall of the roof will be determined by the chosen roof covering or the chosen pitch will limit the range of coverings which can be selected.

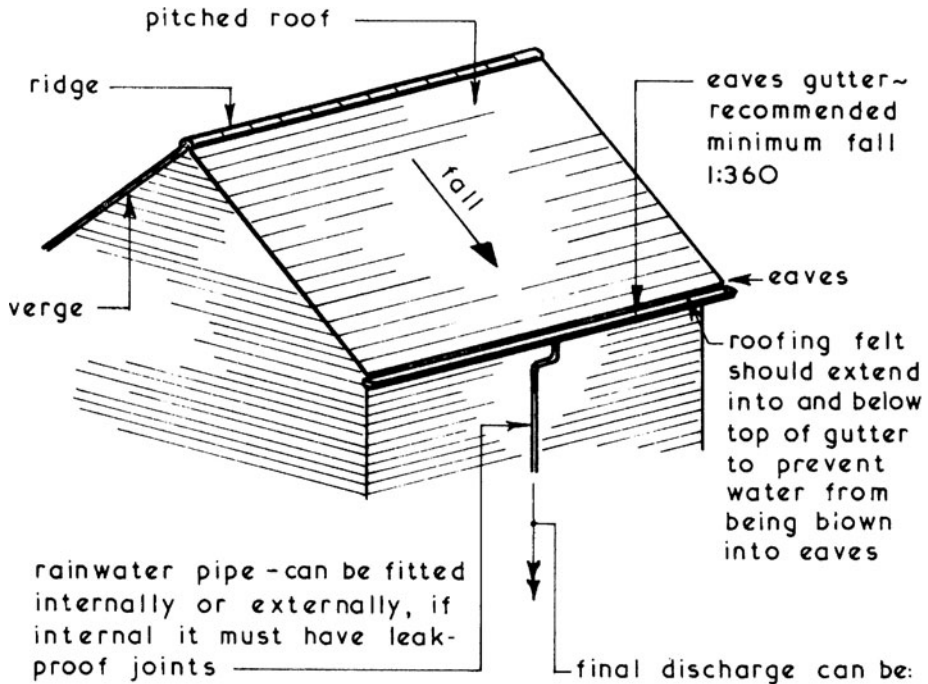

rainwater pipe - can be fitted internally or externally, if internal it must have leak-proof joints

rainwater pipes and gullies must be arranged so as not to cause dampness or damage to any part of the building

Minimum Roof Pitches ~

Slates - depends on width from 25°

Handmade plain tiles - 45°

Machine made plain tiles - 35°

Single lap and interlocking tiles - depends on type from 12½°

Thatch - 45°

Timber shingles - 14°

final discharge can be:

1. Direct connection to a drain discharging into a soakaway
2. Direct connection to a drain discharging into a surface water sewer
3. Indirect connection to a drain by means of a trapped gully if drain discharges into a combined sewer

See page 879 for details.

# Surface Water Removal – Roofs

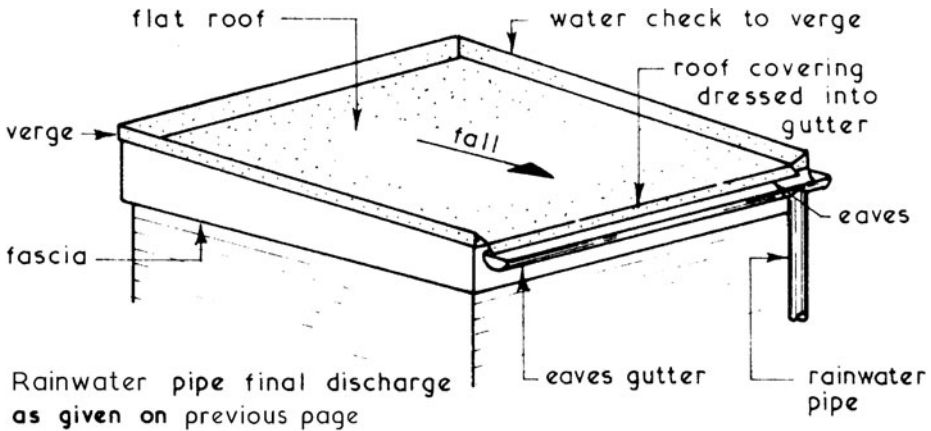

Minimum Recommended Falls for Various Finishes ~

Aluminium - 1:60	Lead - 1:120	Copper - 1:60
Built-up roofing felts - 1:60	Mastic asphalt - 1:80	

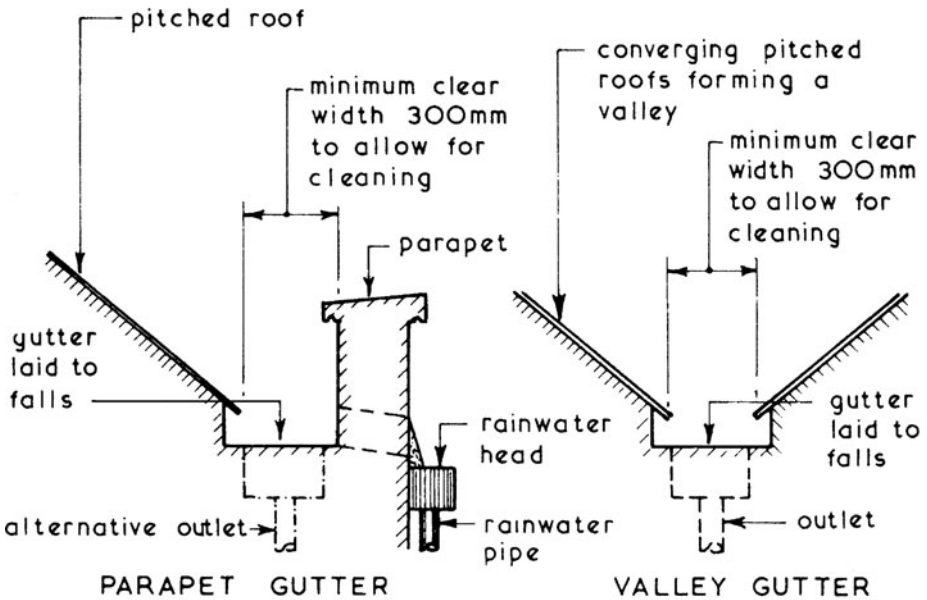

gutter formed to discharge into internal rainwater pipes or to external rainwater pipes via outlets through the parapet

gutter formed to discharge into internal rainwater pipes or to external rainwater pipes sited at the gable ends

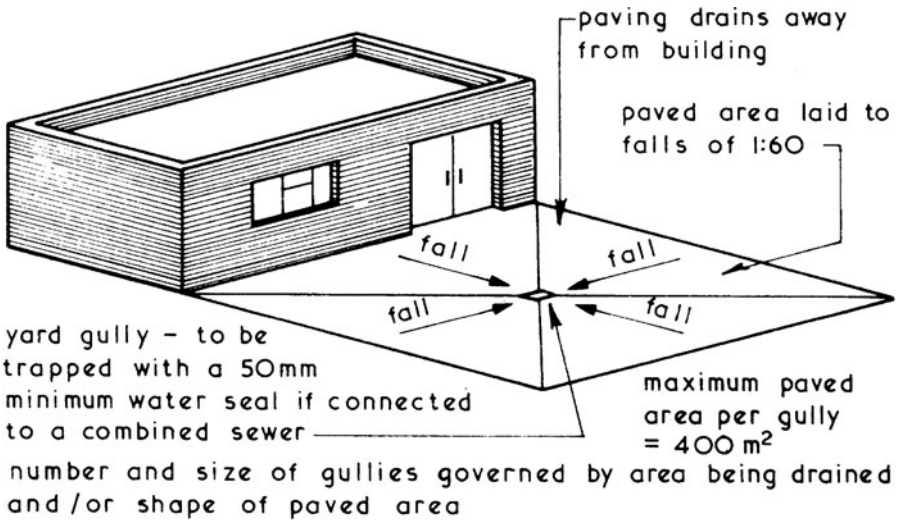

YARD GULLY COLLECTION

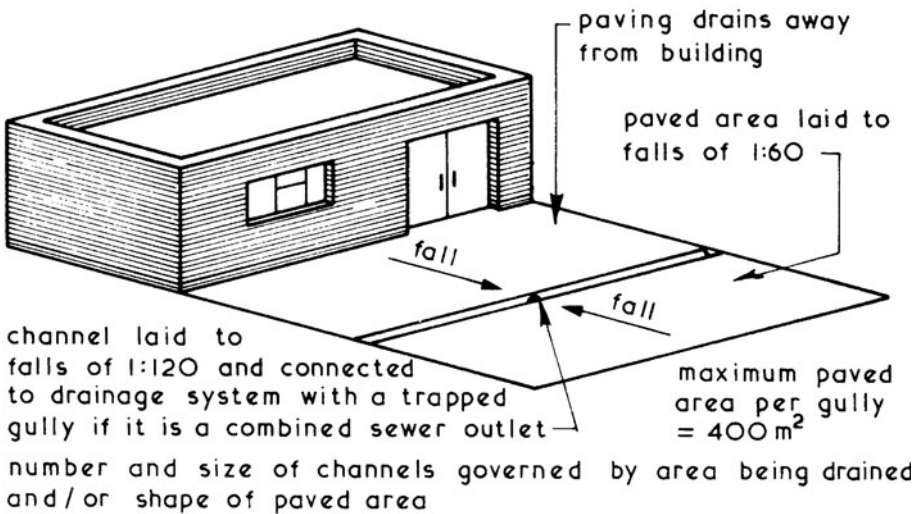

CHANNEL COLLECTION

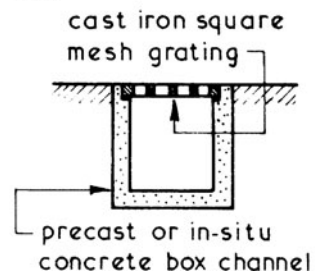
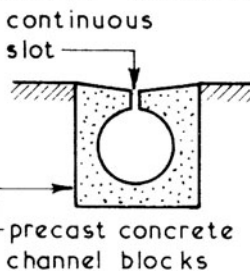
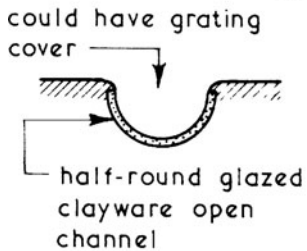

## Surface Water Removal – Sustainable Drainage

Sustainable Drainage Systems (SuDS) otherwise known as Sustainable Urban Drainage Systems (SUDS) cover a variety of applications that are designed to regulate surface water run-off. Their purpose is to control the level of water in the ground during periods of intense rainfall, thereby reducing the risk of flooding.

Problem ~ growth in urbanisation, increase in population, density of development, extreme weather, global warming and climate change are some of the factors that contribute to a rise in ground water table levels and higher volumes of surface water run-off.

Solution ~ before developing land and undertaking major refurbishment projects, it is necessary to design a surface and ground water control system that relieves potential concentrations of rainwater. This should replicate or improve the natural site drainage that existed before groundworks (foundations, basements, etc.) disturb the subgrade.

Applications ~ installation systems that manage surface water by attenuation and filtration as required by the Flood Water Management Act. Measures may include site treatment, containment and rainwater harvesting (see Building Services Handbook) before surface water can be discharged into surface water sewers. SUDS controls such as swales and retention ponds are another option, but space for these is limited or non-existent in urban situations.

Objectives ~

- Improved amenity.
- Improved water resource quality.
- Reduced exposure to flooding.
- Minimised dispersal through foul water drainage systems.
- Regulated natural flow conditions.

Refs.:

- Flood Water Management Act ~ establishes a SuDS approval body (SAB) and amends the automatic right to connect surface water drains to a public surface water sewer, connection subject to conditional standards.
- Building Services Handbook, Part 8 - F. Hall and R. Greeno (Routledge).

## Surface Water Removal – Permeable Paving

Concrete Block Permeable Paving (CBPP) ~ unlike traditional impermeable surfaces that direct surface water to drainage channels and pipes, CBPP filters and removes pollutants before dispersal. Hydrocarbons are degraded and digested by naturally occurring microbes in the sub-base, therefore oil interceptors are not required. Silt traps are also not needed as the system retains silt. Block pavers filter and clean surface water before it is accommodated in the sub-base and slowly released into the ground. In less naturally draining subsoils the retained water percolates into perforated drainage pipes before flowing on to a drainage discharge system.

Permeable Block Paving Installations (see also page 168) ~

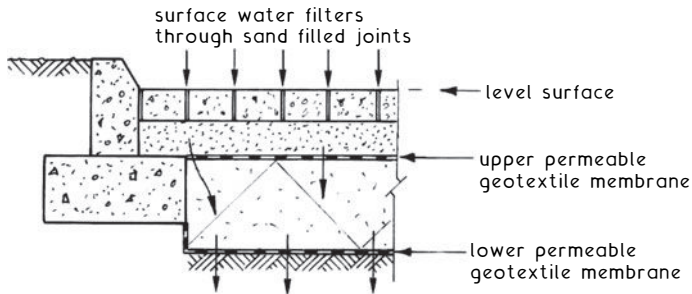

Subgrades of good drainage medium

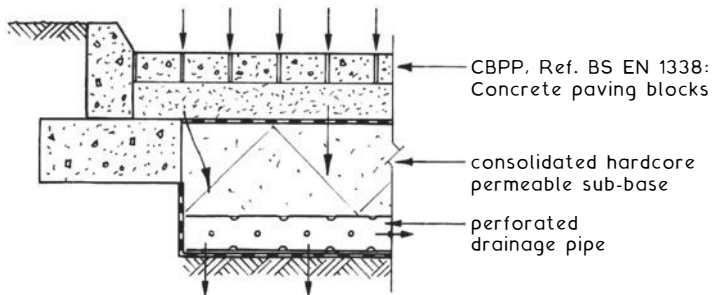

Subgrades composed of material with limited drainage

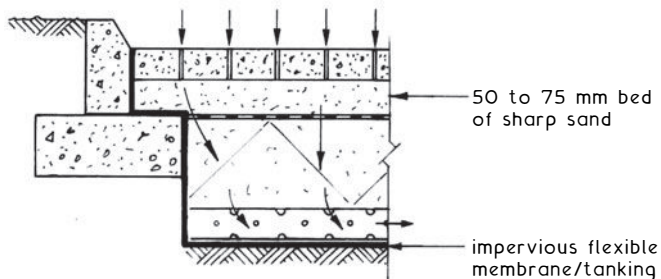

Subgrades of no capacity for infiltration



# Road Drainage

Highway Drainage ~ the stability of a highway or road relies on two factors:

1. Strength and durability of upper surface.
2. Strength and durability of subgrade which is the subsoil on which the highway construction is laid.

The above can be adversely affected by water; therefore it may be necessary to install two drainage systems. One system (subsoil drainage) to reduce the flow of subsoil water through the subgrade under the highway construction and a system of surface water drainage.

## Typical Highway Subsoil Drainage Methods ~

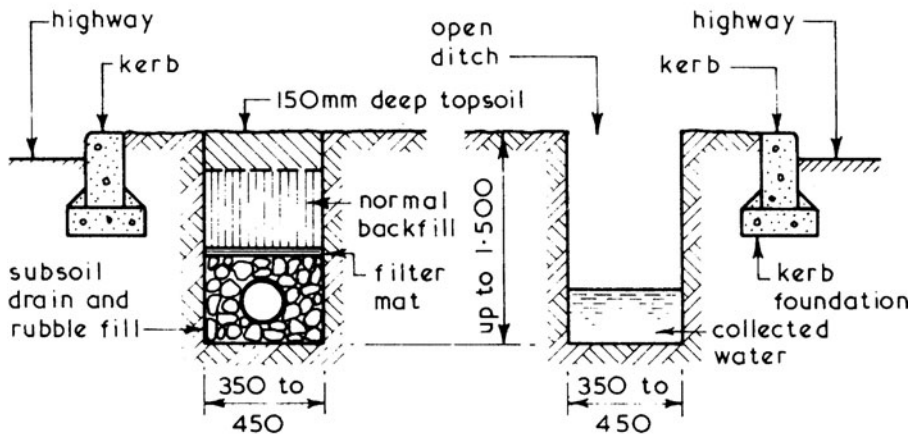

Subsoil Drain - acts as a cut off drain and can be formed using perforated or porous drainpipes. If filled with rubble only it is usually called a French or rubble drain.

Open Ditch - acts as a cut off drain and could also be used to collect surface water discharged from a rural road where there is no raised kerb or surface water drains.

## Surface Water Drainage Systems ~

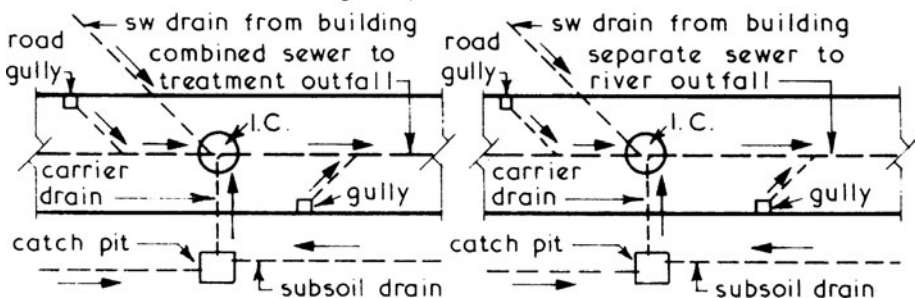

Road Drainage ~ this consists of laying the paved area or road to a suitable crossfall or gradient to direct the run-off of surface water towards the drainage channel or gutter. This is usually bounded by a kerb which helps to convey the water to the road gullies which are connected to a surface water sewer. For drains or sewers under 900mm internal diameter inspection chambers will be required as set out in the Building Regulations. The actual spacing of road gullies is usually determined by the local highway authority based upon the carriageway gradient and the area to be drained into one road gully. Alternatively the following formula could be used:

$$D = \frac{280\sqrt{S}}{W} \quad \text{where } D = \text{gully spacing}$$

$$S = \text{carriageway gradient (per cent)}$$

$$W = \text{width of carriageway in metres}$$

∴ If  $S = 1:60 = 1.66\%$  and  $W = 4.500$

$$D = \frac{280\sqrt{1.66}}{4.500} = \text{say } 80.000$$

Typical Road Gully Detail ~

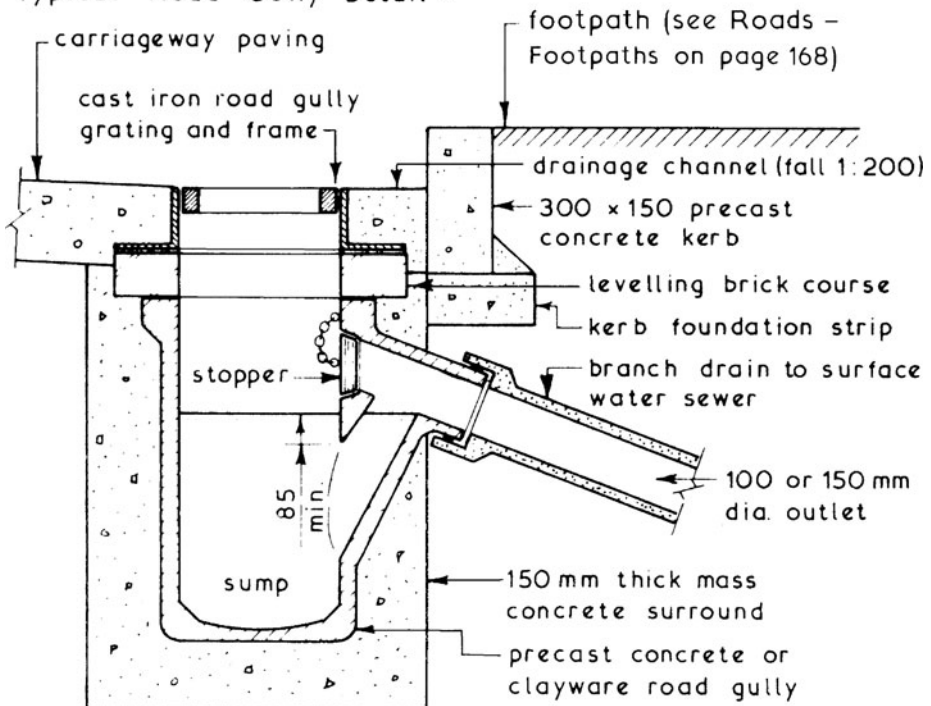

## Rainwater Installation Details

Materials ~ the traditional material for domestic eaves gutters and rainwater pipes is cast iron but uPVC systems are very often specified today because of their simple installation and low maintenance costs. Other materials which could be considered are aluminium alloy, galvanised steel and stainless steel, but whatever material is chosen it must be of adequate size, strength and durability.

### Typical Eaves Details ~

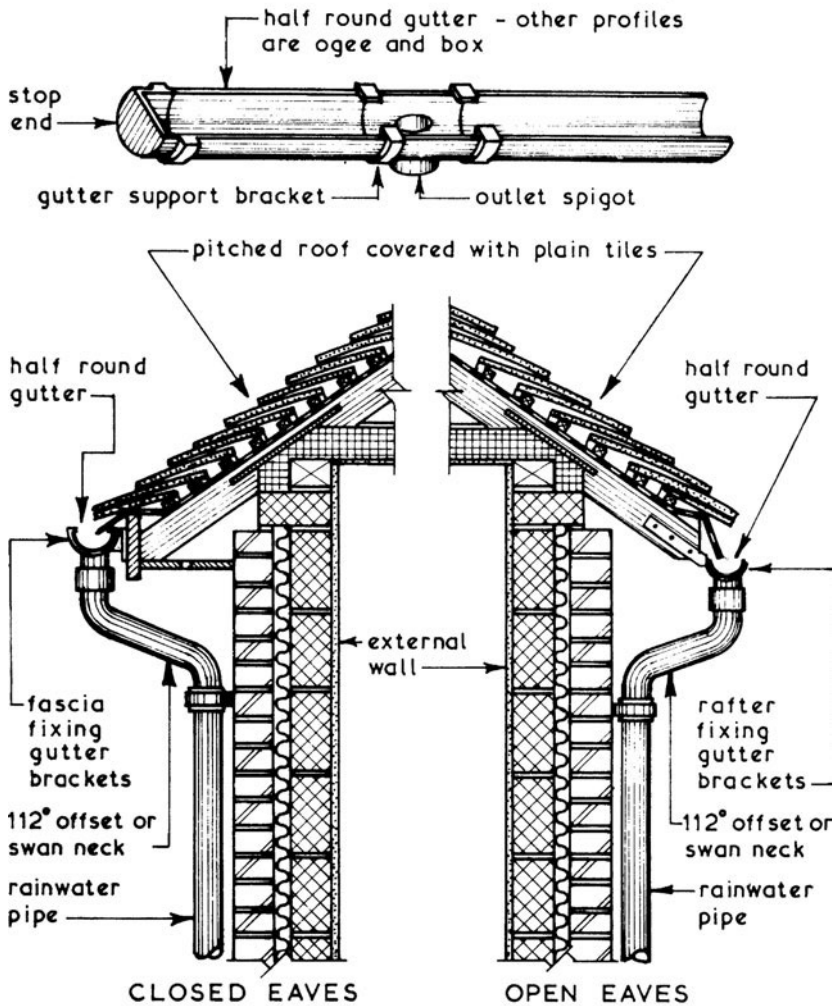

For details of rainwater pipe connection to drainage see next page.

Note: Details show established construction with a block cavity closer course. New construction to have insulation continuity to prevent cold bridging. See page 507.

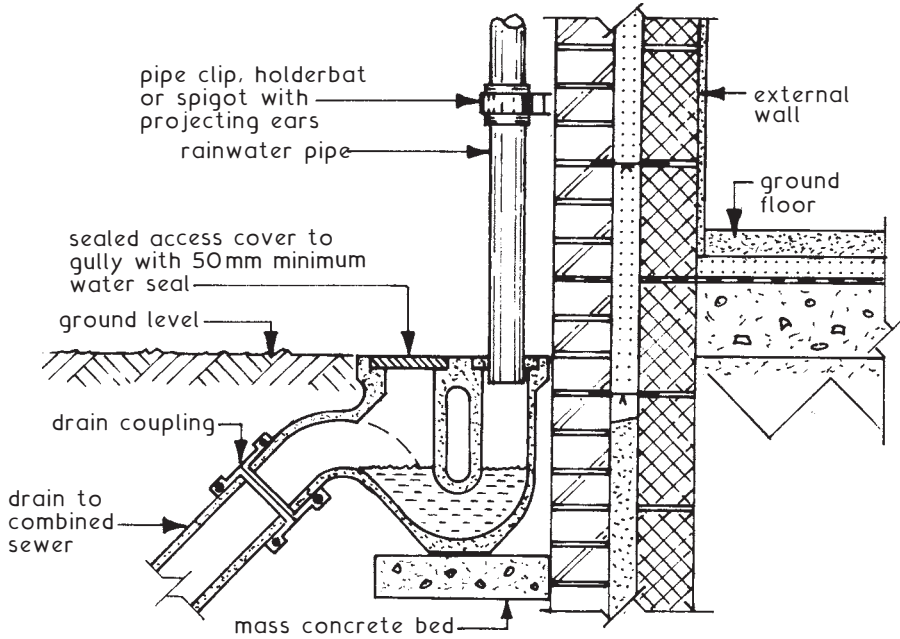
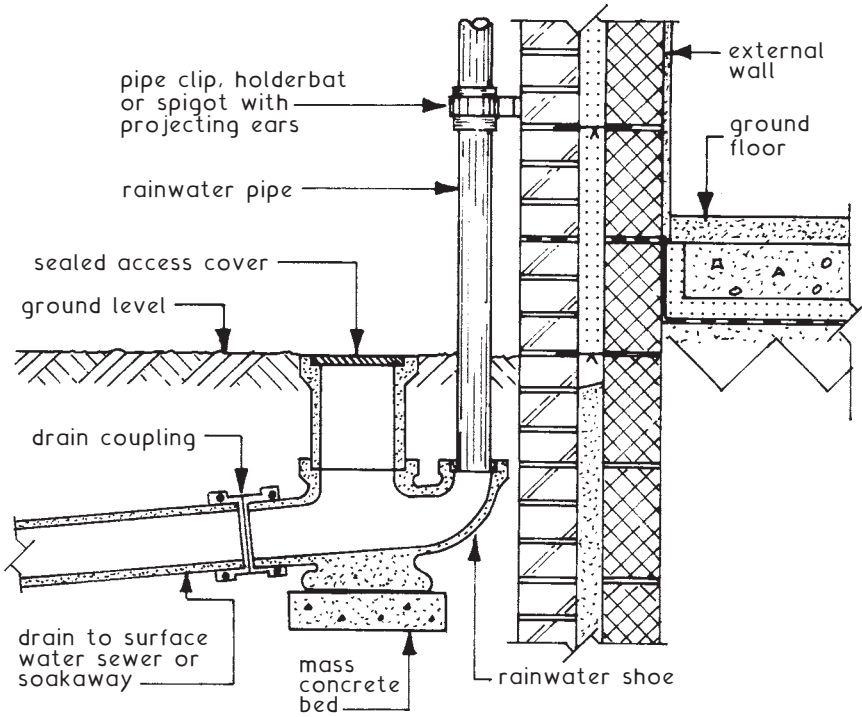

NB. For details of rainwater pipe connection to gutter see previous page.

## Rainwater Drainage – Soakaways

Soakaways ~ provide a means for collecting and controlling the seepage of rainwater into surrounding granular subsoils. They are not suitable in clay subsoils. Siting is on land at least level and preferably lower than adjacent buildings and no closer than 5m to a building. Concentration of a large volume of water any closer could undermine the foundations. The simplest soakaway is a rubble-filled pit, which is normally adequate to serve a dwelling or other small building. Where several buildings share a soakaway, the pit should be lined with precast perforated concrete rings and surrounded in free-draining material.

BRE Digest 365 provides capacity calculations based on percolation tests. The following empirical formula will prove adequate for most situations:

$$C = \frac{AR}{3}$$

where: C = capacity (m<sup>3</sup>)

A = area on plan to be drained (m<sup>2</sup>)

R = rainfall (m/h)

e.g. roof plan area 60m<sup>2</sup> and rainfall of 50mm/h (0.05m/h)

$$C = \frac{60 \times 0.05}{3} = 1.0 \text{ m}^3 \text{ (below invert of discharge pipe)}$$

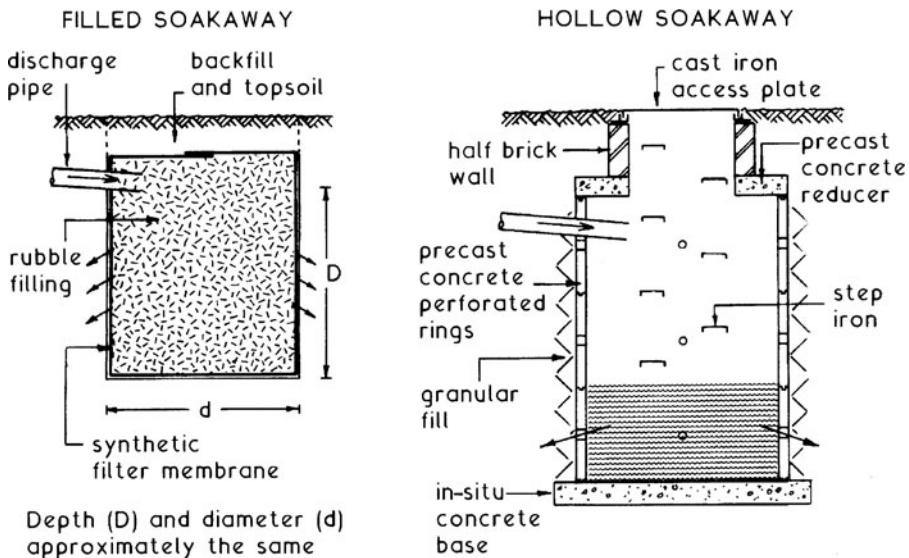

Ref. BRE Digest 365: Soakaways.

**Drains** ~ these can be defined as a means of conveying surface water or foul water below ground level from one building only. Within the curtilage of that building they are the responsibility of the building owner.

**Sewers** ~ these have the same functions as drains but collect the discharge from a number of drains and convey it to the final outfall. Shared and public sewers are maintained by the local water and sewerage authority.

**Basic Principles** ~ to provide a drainage system which is simple, efficient and economical by laying the drains to a gradient which will render them self-cleansing and will convey the effluent to a sewer without danger to health or giving nuisance. To provide a drainage system which will comply with the minimum requirements given in Part H of the Building Regulations.

**Typical Basic Requirements** ~

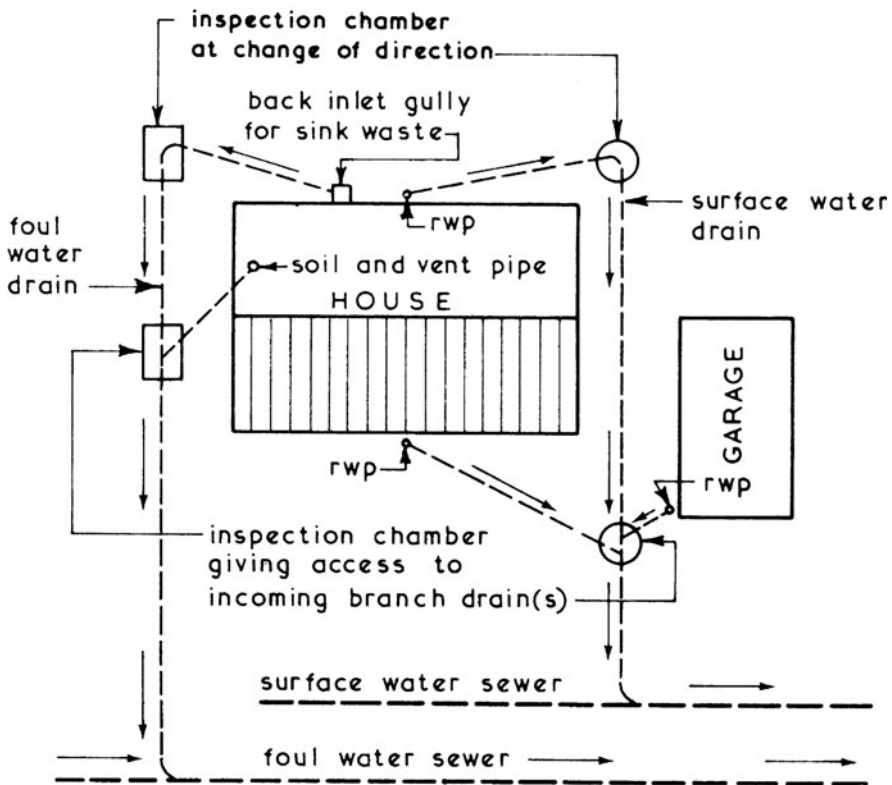

All junctions should be oblique and in direction of flow

There must be an access point at a junction unless each run can be cleared from another access point.

# Drainage Systems

Separate System ~ the most common drainage system in use where the surface water discharge is conveyed in separate drains and sewers to that of foul water discharges and therefore receives no treatment before the final outfall.

Typical Example ~

if subsoil is suitable the rainwater pipes may be allowed to be connected direct to soakaways

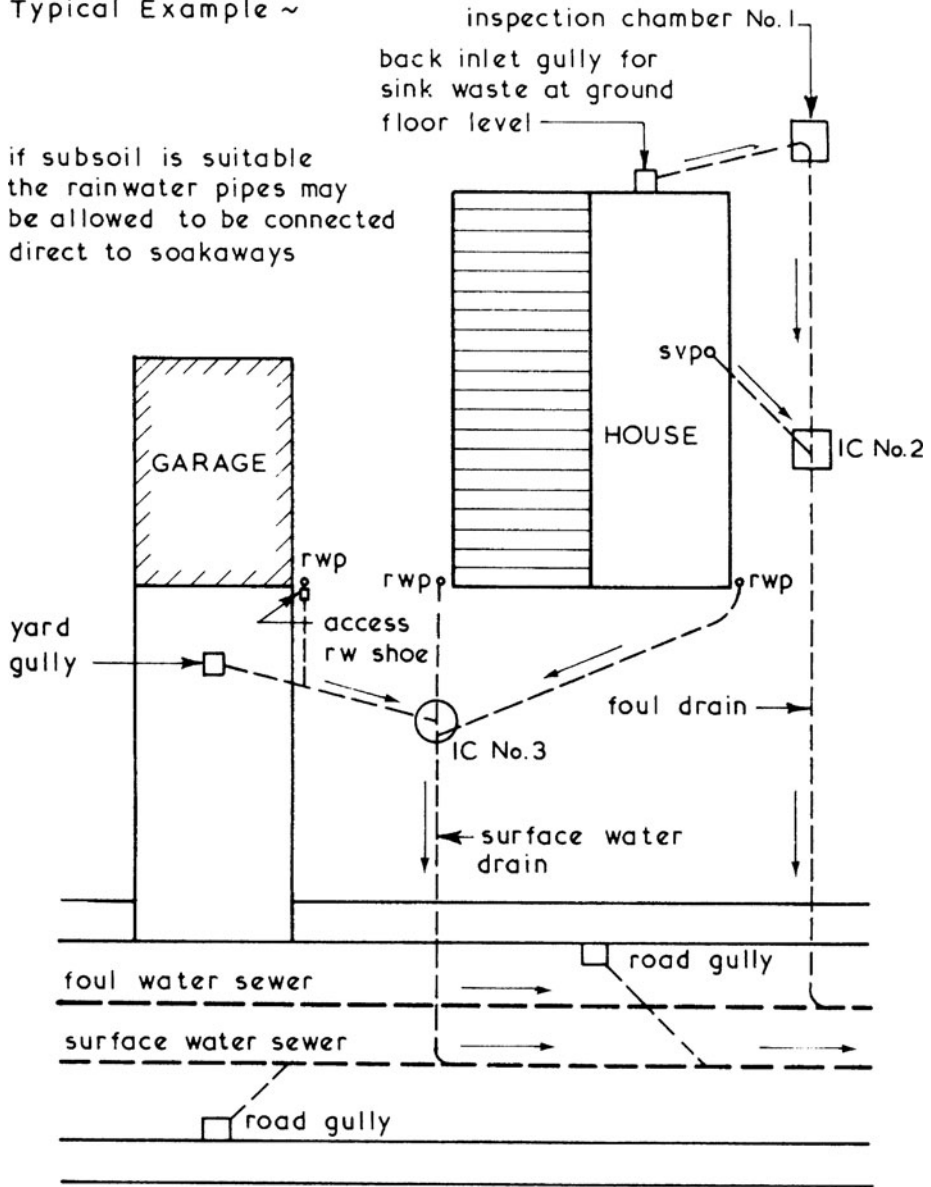

Combined System ~ this is the simplest and least expensive system to design and install but since all forms of discharge are conveyed in the same sewer the whole effluent must be treated unless a sea outfall is used to discharge the untreated effluent.

Typical Example ~

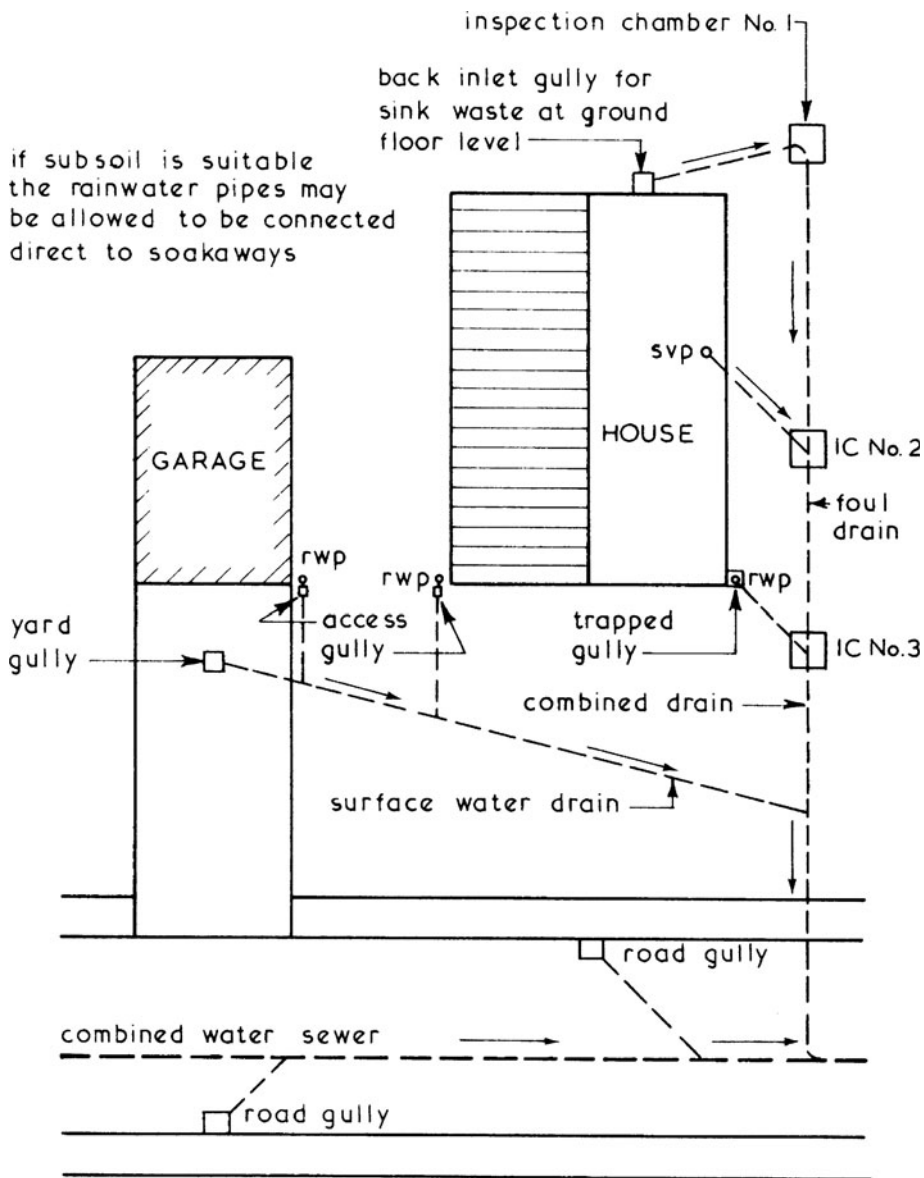

Ref. BS EN 752: Drain and sewer systems outside buildings.



# Drainage Systems

Partially Separate System ~ a compromise system - there are two drains, one to convey only surface water and a combined drain to convey the total foul discharge and a proportion of the surface water.

Typical Example ~

if subsoil is suitable the rainwater pipes may be allowed to be connected direct to soakaways

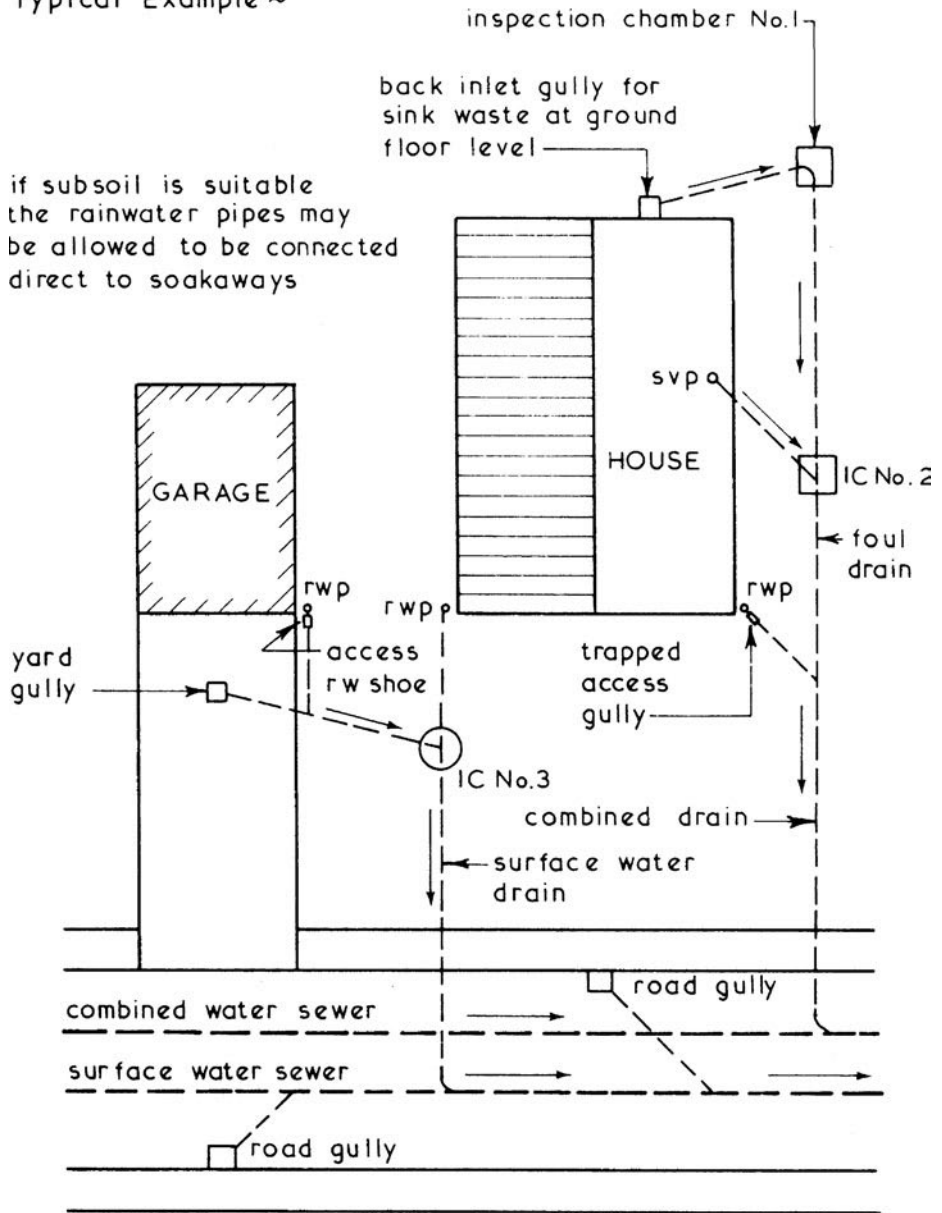

Public Sewer ~ a sewer or drain that is owned or adopted by the local council or water authority/sewerage undertaker. Sewer pipes are at least 300mm nominal diameter, even when serving small housing sites. Surplus capacity will accommodate further connections for any later development without the expense of replacing the sewer.

Location ~ usually under public roads at a minimum depth of 1.2m, but may be within the boundary of a property where there has been later development or where it is proposed to further develop an established site. Old sewers, many of which were installed over 100 years ago, may not have documentation confirming their course. Others that were recorded are not necessarily accurate.

Damage Potential ~ some of the original sewers serving major cities were created as tunnels of brick construction and many are still functional. Whether tunnels or rigid clay pipes for tributary sewers, they will inevitably have suffered some deterioration from the effects of traffic vibration, superimposed loading, impact from new building work, road improvements and installation of other underground services in the vicinity. Cracking, fracture and even collapse can result, interrupting the drainage facility and possibly causing settlement damage to adjacent structures. Sewer repair on this scale will probably mean demolition of buildings or part of a building to effect access, or at least temporary structural support and underpinning.

Planning ~ initial consultation with the local planning authority to locate sewers. The building control department in conjunction with their highways department and possibly the local water authority/sewerage undertaking will determine from their records whether proposed building work is likely to be affected by sewer proximity.

Requirements where a sewer exists close by:

- New building work no closer than 3.0m to a sewer.
- Sewer diversion to satisfy the 3.0m dimension.
- Pipes of 150mm nominal diameter or less may be accepted within 3.0m distance if they are at a significant depth or protected by a reinforced concrete cover. This is more appropriate for drains, and guidance is available in Building Regulations Approved Document H, Section 2.

Ref. Water Industry Act.

## Simple Drainage – Inspection Chambers

Inspection Chambers ~ these provide a means of access to drainage systems where the depth to invert level does not exceed 1:000.

Manholes ~ these are also a means of access to the drains and sewers, and are so called if the depth to invert level exceeds 1:000.

These means of access should be positioned in accordance with the requirements of part H of the Building Regulations. In domestic work inspection chambers can be of brick, precast concrete or preformed in plastic for use with patent drainage systems. The size of an inspection chamber depends on the depth to invert level, drain diameter and number of branch drains to be accommodated within the chamber. Ref. BS EN 752: Drain and sewer systems outside buildings.

### Typical Details ~

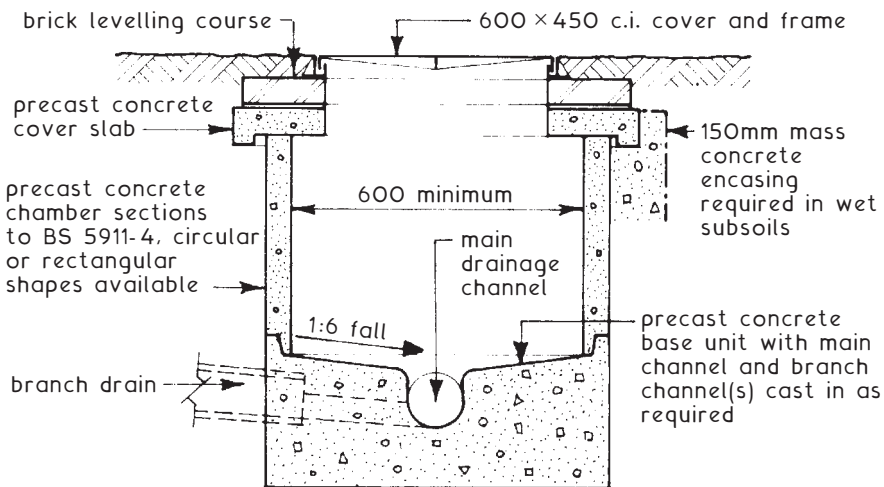
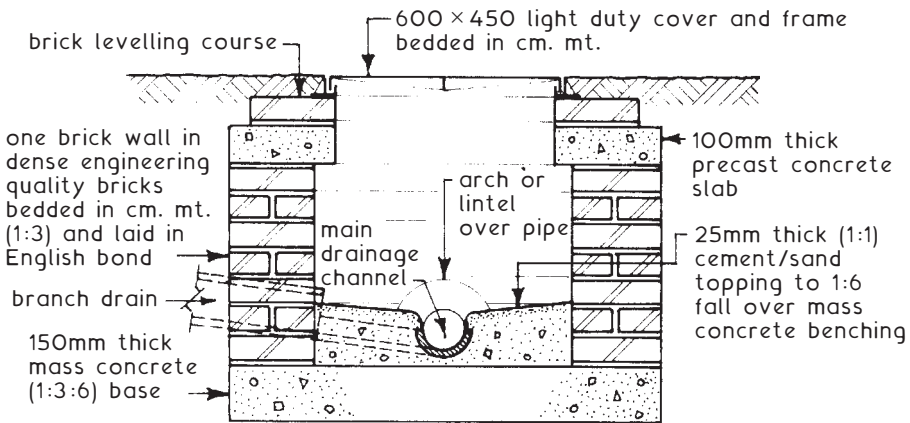

step irons required for invert levels over 1:200 deep

## Simple Drainage – Inspection Chambers

Plastic Inspection Chambers ~ the raising piece can be sawn horizontally with a carpenter's saw to suit depth requirements with the cover and frame fitted at surface level. Bedding may be a 100mm prepared shingle base or 150mm wet concrete to ensure a uniform support.

The unit may need weighting to retain it in place in areas of high water table, until backfilled with granular material. Under roads a peripheral concrete collar is applied to the top of the chamber in addition to the 150mm thickness of concrete surrounding the inspection chamber.

Typical Example ~

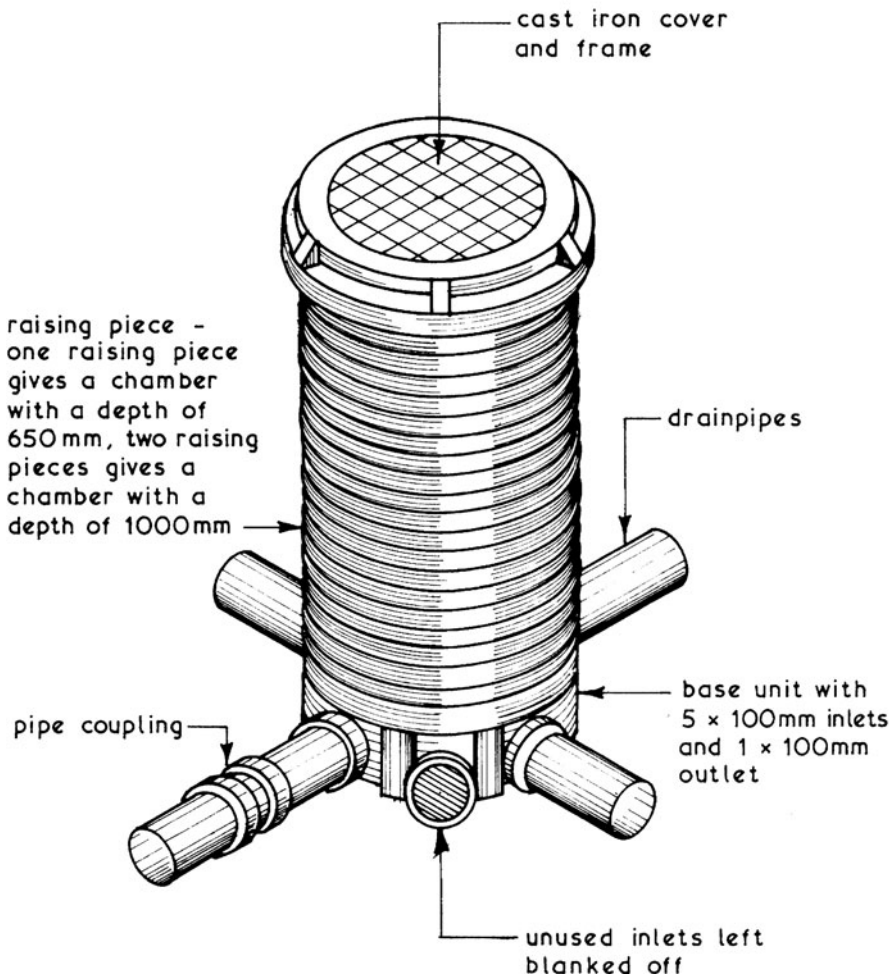

## Simple Drainage – Access Location

Means Of Access – provision is required for maintenance and inspection of drainage systems. This should occur at:

- \* the head (highest part) or close to it
- \* a change in horizontal direction
- \* a change in vertical direction (gradient)
- \* a change in pipe diameter
- \* a junction, unless the junction can be rodded through from an access point
- \* long straight runs (see table)

Maximum spacing of drain access points (m)

	To:	Small access fitting*	Large access fitting*	Junction	Inspection chamber	Manhole
From:						
Drain head		12	12		22	45
Rodding eye		22	22	22	45	45
Small access fitting				12	22	22
Large access fitting				22	45	45
Inspection chamber		22	45	22	45	45
Manhole					45	90

\* Small access fitting is 150mm dia. or 150mm × 100mm. Large access fitting is 225mm × 100mm.

Rodding Eyes and Shallow Access Chambers – these may be used at the higher parts of drainage systems where the volume of excavation and cost of an inspection chamber or manhole would be unnecessary. SACs have the advantage of providing access in both directions. Covers to all drain openings should be secured to deter unauthorised access.

Ref. Building Regulations, Approved Document H1: Foul Water Drainage.

## Simple Drainage – Drain Laying

Excavations ~ drains are laid in trenches which are set out, excavated and supported in a similar manner to foundation trenches except for the base of the trench which is cut to the required gradient or fall.

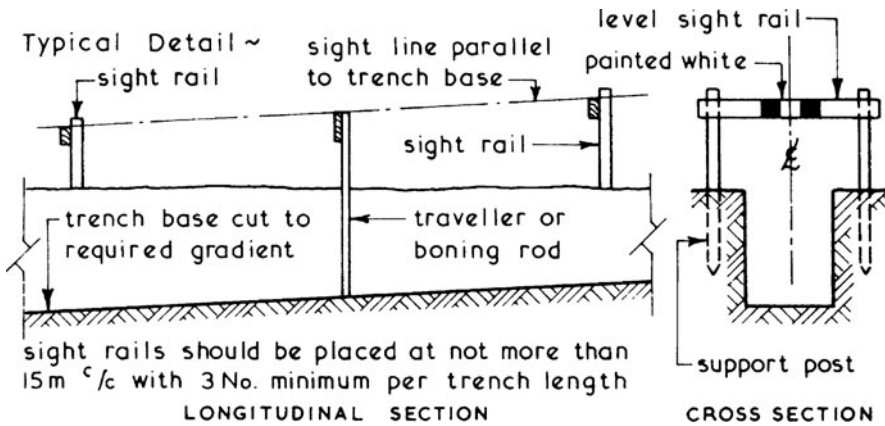

Joints ~ these must be watertight under all working and movement conditions and this can be achieved by using rigid and flexible joints in conjunction with the appropriate bedding.

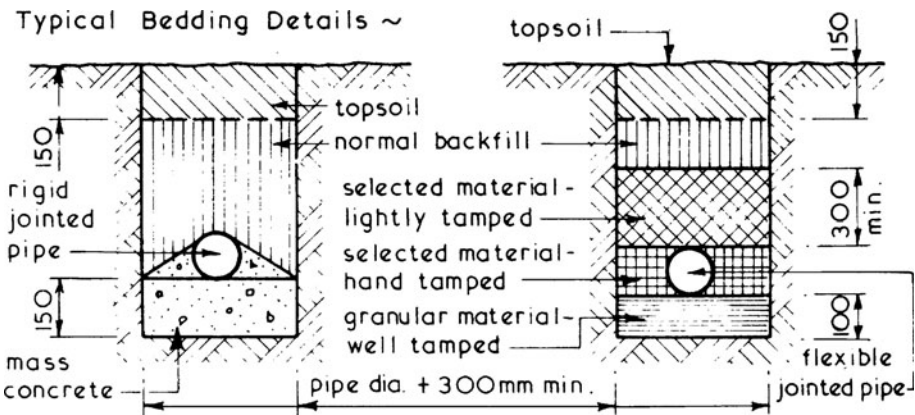
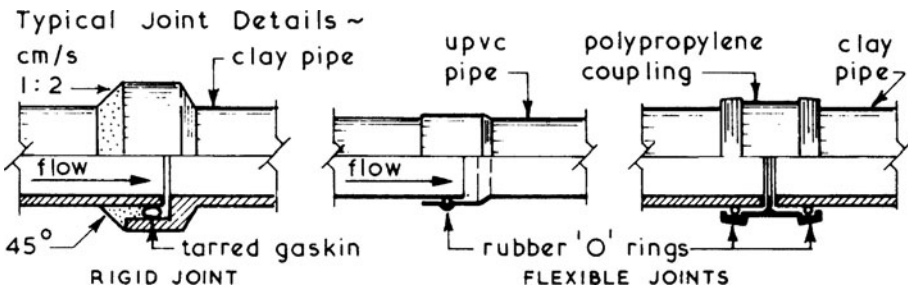

## Drainage Systems – Testing

Watertightness ~ must be ensured to prevent water seepage and erosion of the subsoil. Also, in the interests of public health, foul water should not escape untreated. The Building Regulations, Approved Document H1: Section 2 specifies either an air or water test to determine soundness of installation.

AIR TEST ~ equipment: Manometer and accessories (see page 912)  
two drain stoppers, one with tube attachment

Application ~

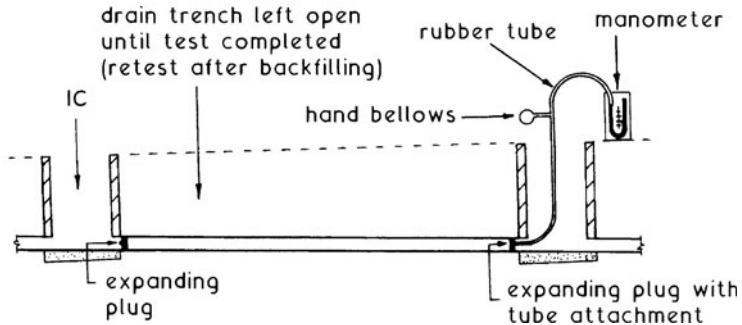

Test ~ 100mm water gauge to fall no more than 25mm in five mins. Or, 50mm w.g. to fall no more than 12mm in five mins.

WATER TEST ~ equipment: Drain stopper  
Test bend  
Extension pipe

Application ~

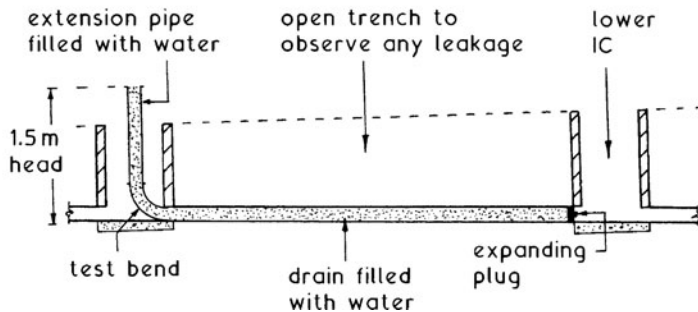

Test ~ 1.5m head of water to stand for two hours and then topped up. Leakage over the next 30 minutes should be minimal, i.e.:

100mm pipe - 0.05 litres per metre, which equates to a drop of 6.4mm/m in the extension pipe, and

150mm pipe - 0.08 litres per metre, which equates to a drop of 4.5mm/m in the extension pipe.

Drainage Pipes ~ sizes for normal domestic foul water applications:

<20 dwellings = 100mm nominal inside diameter

20–150 dwellings = 150mm nominal inside diameter

Exceptions: 75mm diameter for waste or rainwater only (no WCs)

150mm diameter minimum for a public sewer

Other situations can be assessed by summing the Discharge Units from appliances and converting these to an appropriate diameter stack and drain, see BS EN 12056-2 (stack) and BS EN 752 (drain). Gradient will also affect pipe capacity and when combined with discharge calculations, provides the basis for complex hydraulic theories.

The simplest correlation of pipe size and fall is represented in Maguire's rule:

4" (100mm) pipe, minimum gradient 1 in 40

6" (150mm) pipe, minimum gradient 1 in 60

9" (225mm) pipe, minimum gradient 1 in 90

The Building Regulations, approved Document H1 provides more scope and relates to foul water drains running at 0.75 proportional depth. See Diagram 9 and Table 6 in Section 2 of the Approved Document.

Other situations outside of design tables and empirical practice can be calculated.

E.g. A 150mm diameter pipe flowing 0.5 proportional depth.

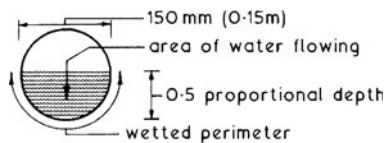

Applying the Chezy formula for gradient calculations:

$$v = c\sqrt{m \times i}$$

where:  $v$  = velocity of flow (min for self-cleansing = 0.8m/s)

$c$  = Chezy coefficient (58)

$m$  = hydraulic mean depth or:

$$\frac{\text{area of water flowing}}{\text{wetted perimeter}} \quad \text{for } 0.5 \text{ p.d.} = \text{diam}/4$$

$i$  = inclination or gradient as a fraction 1/x

Selecting a velocity of 1m/s as a margin of safety over the minimum:

$$1 = 58\sqrt{0.15/4 \times i}$$

$$i = 0.0079 \quad \text{where } i = 1/x$$

So,  $x = 1/0.0079 = 126$ , i.e. a minimum gradient of 1 in 126



## Water Supply – Basic Requirements

Water Supply ~ an adequate supply of cold water of drinking quality should be provided to every residential building and a drinking water tap installed within the building. The installation should be designed to prevent waste, undue consumption, misuse, contamination of general supply, be protected against corrosion and frost damage and be accessible for maintenance activities. The intake of a cold water supply to a building is owned jointly by the water authority and the consumer who therefore have joint maintenance responsibilities.

### Typical Water Supply Arrangement ~

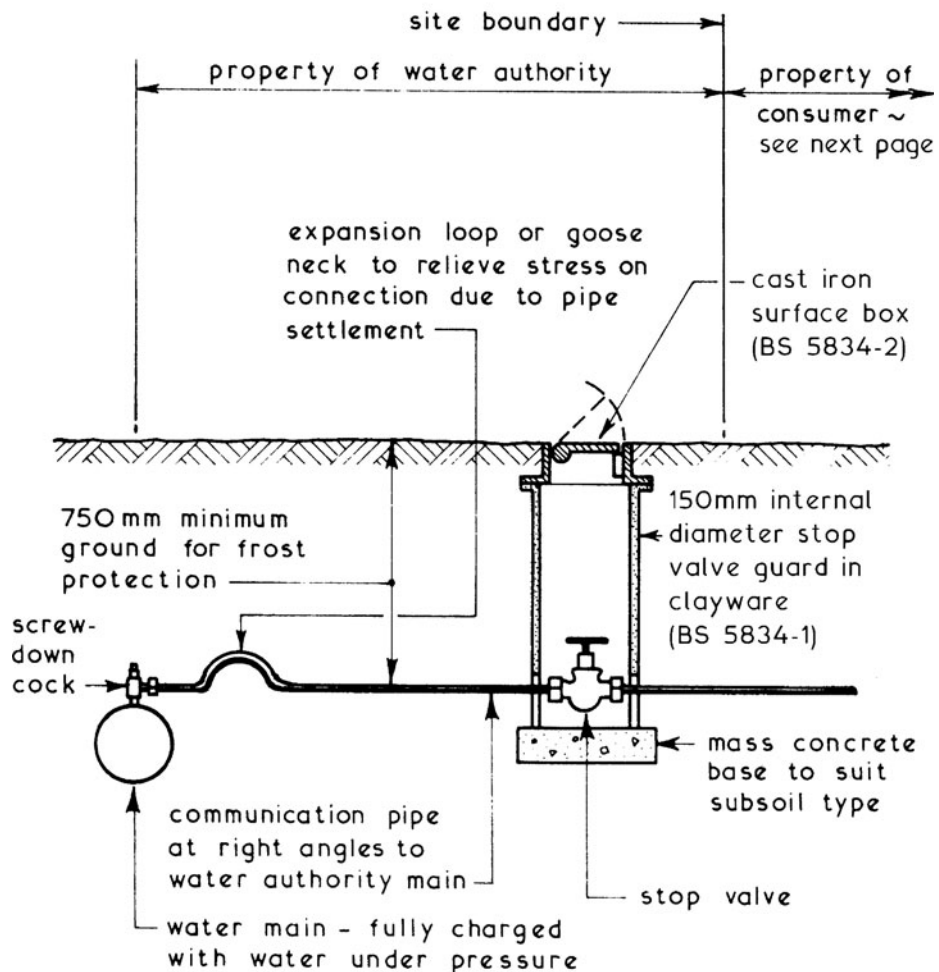

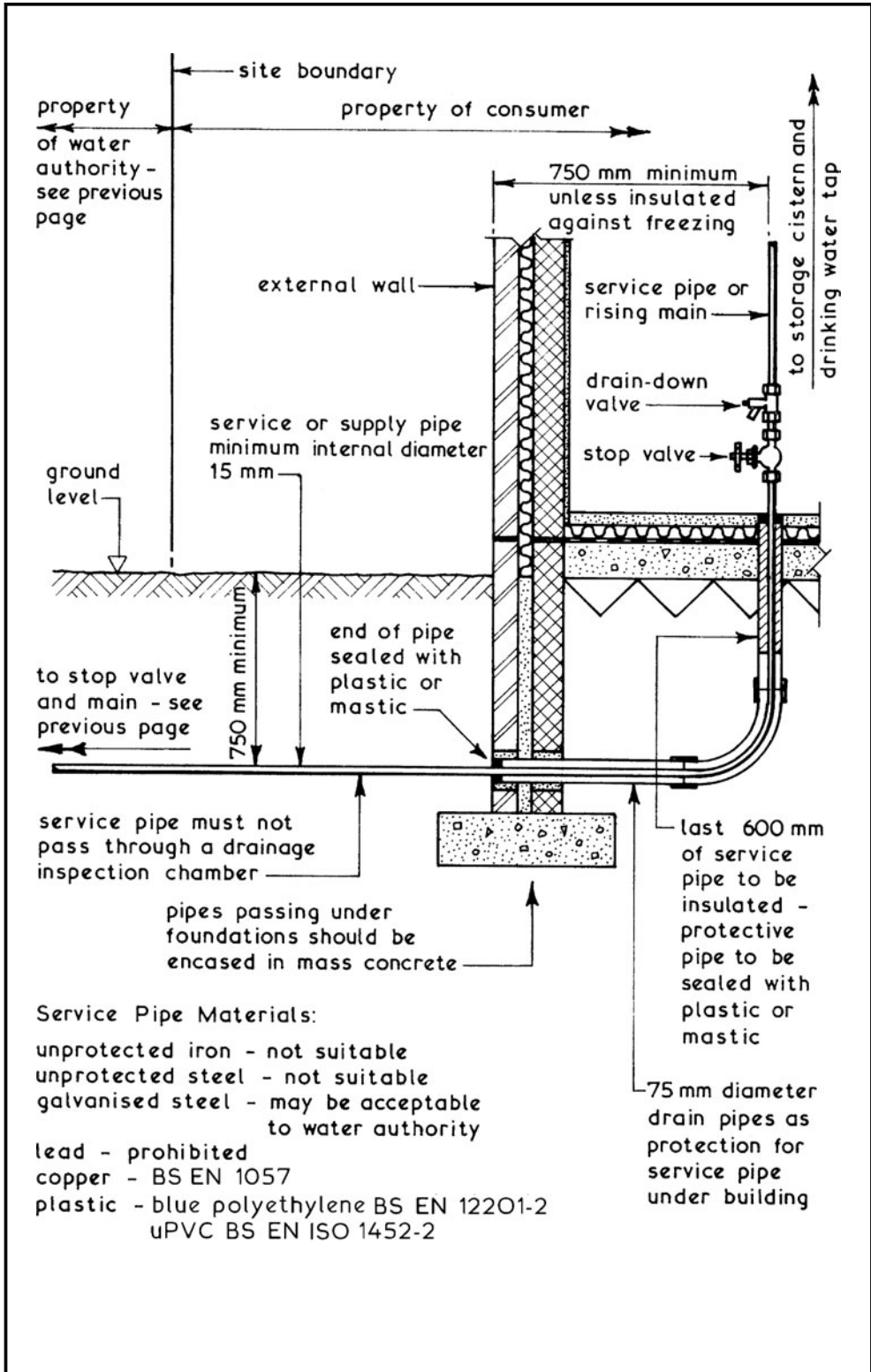

## Cold Water Installations

General ~ when planning or designing any water installation the basic physical laws must be considered:

1. Water is subject to the force of gravity and will find its own level.
2. To overcome friction within the conveying pipes water which is stored prior to distribution will require to be under pressure and this is normally achieved by storing the water at a level above the level of the outlets. The vertical distance between these levels is usually called the head.
3. Water becomes less dense as its temperature is raised, therefore warm water will always displace colder water whether in a closed or open circuit.

Direct Cold Water Systems ~ the cold water is supplied to the outlets at mains pressure; the only storage requirement is a small capacity cistern to feed the hot water storage tank. These systems are suitable for districts which have high level reservoirs with a good supply and pressure. The main advantage is that drinking water is available from all cold water outlets, disadvantages include lack of reserve in case of supply cut off, risk of back syphonage due to negative mains pressure and a risk of reduced pressure during peak demand periods.

Typical Direct Cold Water System ~

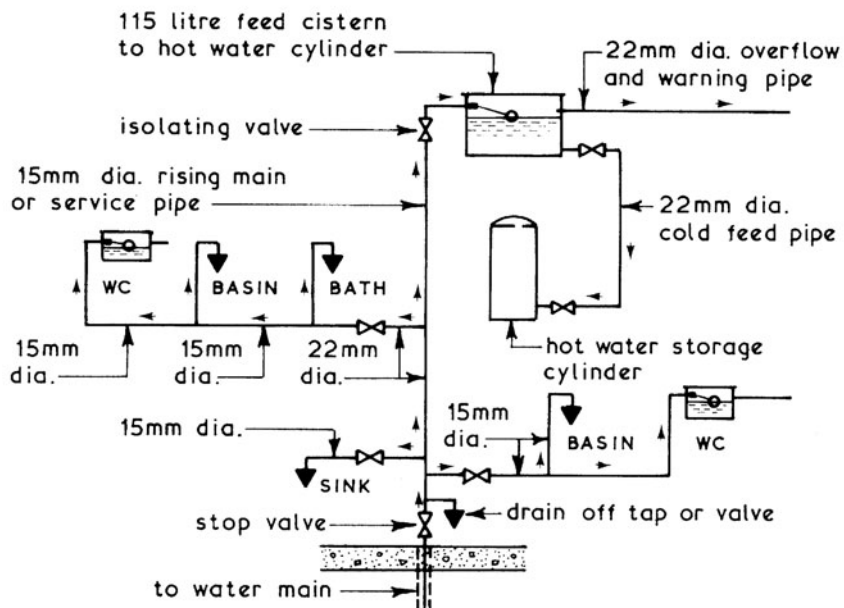

NB. All pipe sizes given are outside diameters for copper tube.

Indirect Systems ~ Cold water is supplied to all outlets from a cold water storage cistern except for the cold water supply to the sink(s) where the drinking water tap is connected directly to incoming supply from the main. This system requires more pipework than the direct system but it reduces the risk of back syphonage and provides a reserve of water should the mains supply fail or be cut off. The local water authority will stipulate the system to be used in their area.

#### Typical Indirect Cold Water System ~

cold water storage cistern minimum capacity 230 litres if used as a feed cistern and storage or 115 litres for storage only

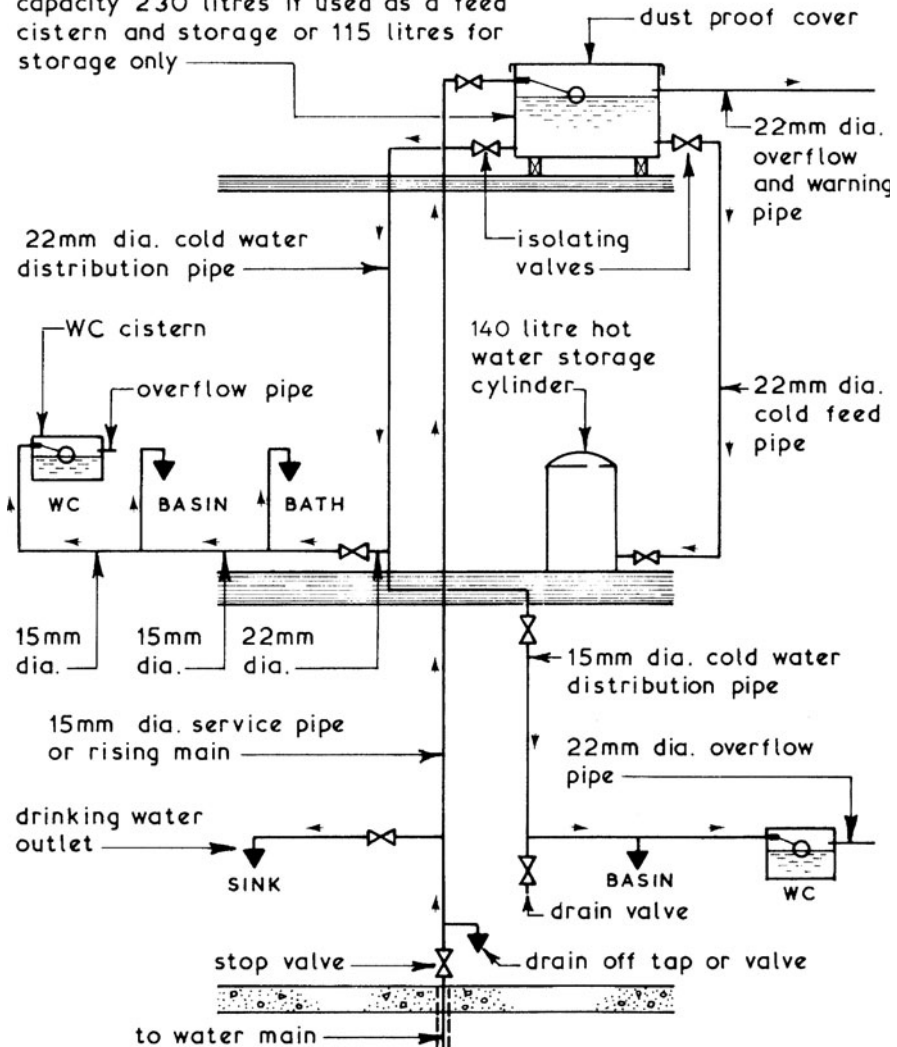

NB. All pipe sizes given are outside diameters for copper tube.

# Hot Water Installations

Direct System ~ this is the simplest and least expensive system of hot water installation. The water is heated in the boiler and the hot water rises by convection to the hot water storage tank or cylinder to be replaced by the cooler water from the bottom of the storage vessel. Hot water drawn from storage is replaced with cold water from the cold water storage cistern. Direct systems are suitable for soft water areas and for installations which are not supplying a central heating circuit.

## Typical Direct Hot Water System ~

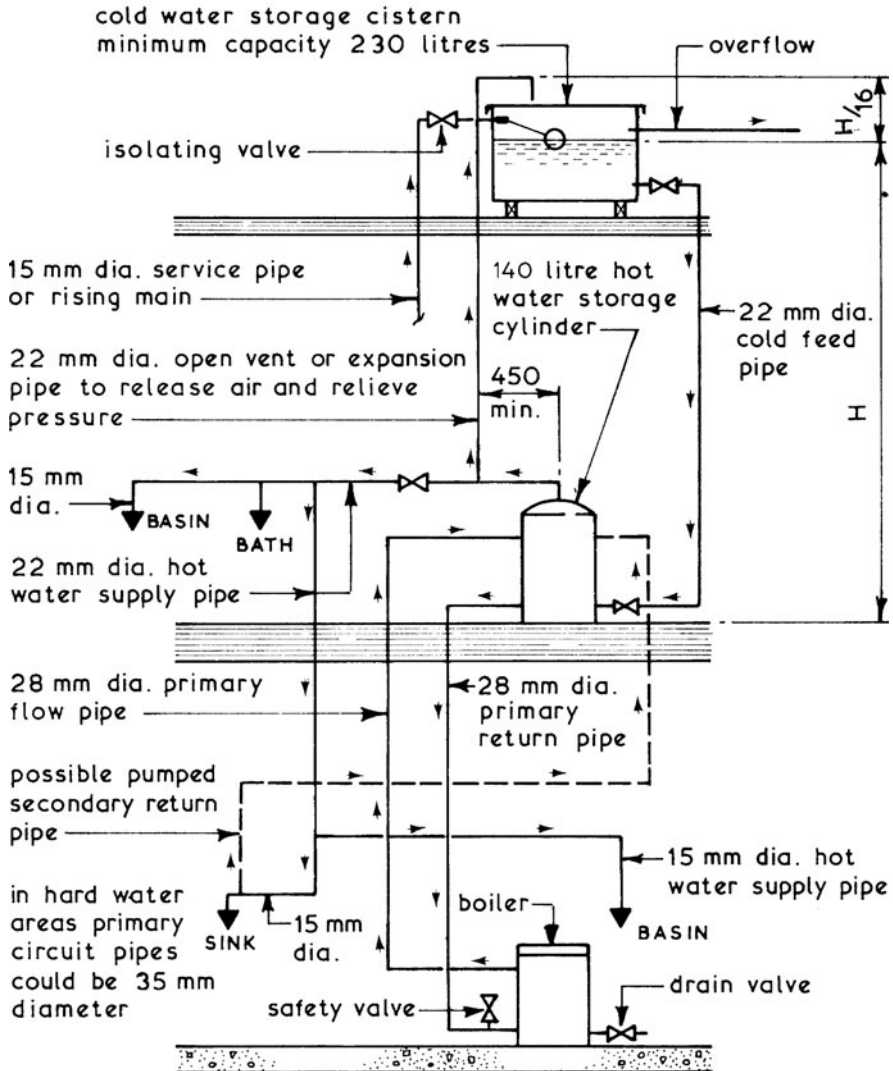

NB. All pipe sizes given are outside diameters for copper tube.

Indirect System ~ this is a more complex system than the direct system but it does overcome the problem of furring which can occur in direct hot water systems. This method is therefore suitable for hard water areas and in all systems where a central heating circuit is to be part of the hot water installation. Basically the pipe layouts of the two systems are similar but in the indirect system a separate small capacity feed cistern is required to charge and top up the primary circuit. In this system the hot water storage tank or cylinder is in fact a heat exchanger - see page 903.

### Typical Indirect Hot Water System ~

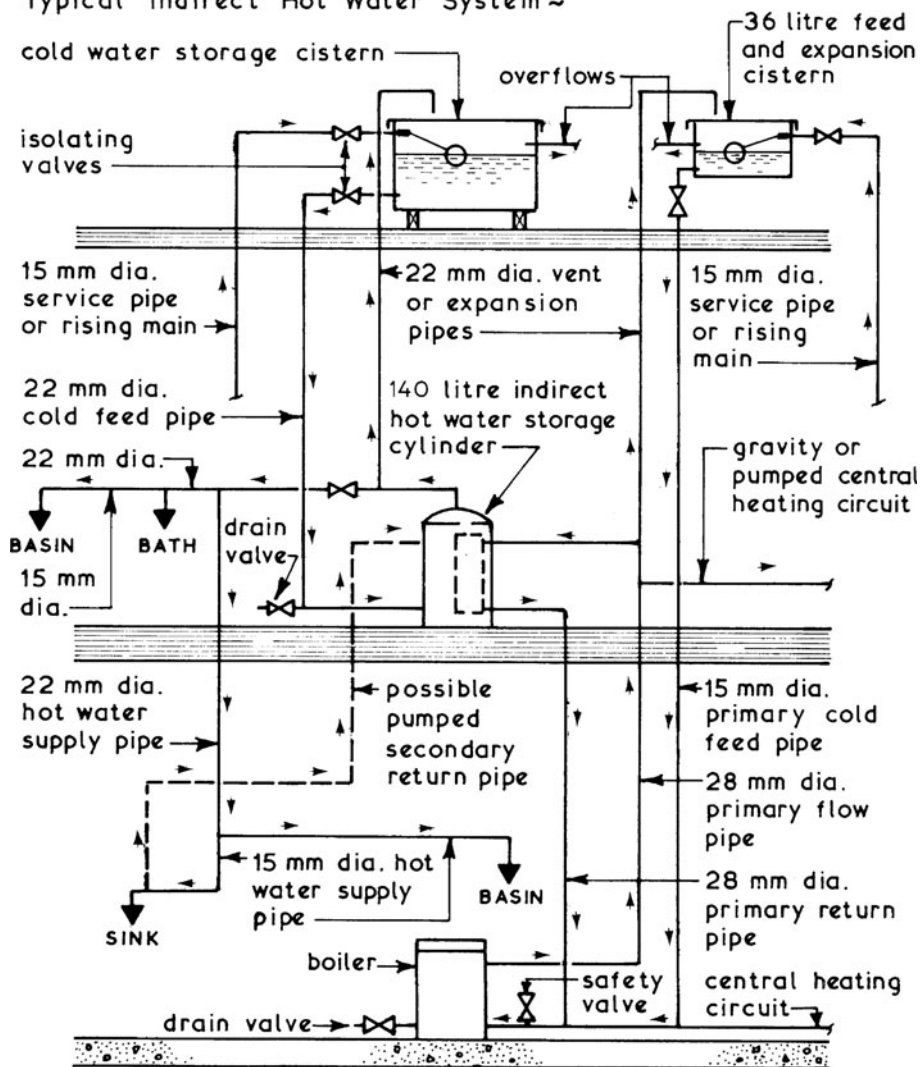

NB. All pipe sizes given are outside diameters for copper tube.

# Hot Water Installations

Mains Fed Indirect System ~ now widely used as an alternative to conventional systems. It eliminates the need for cold water storage and saves considerably on installation time. This system is established in Europe and the USA, but only acceptable in the UK at the local water authority's discretion. It complements electric heating systems, where a boiler is not required. An expansion vessel replaces the standard vent and expansion pipe and may be integrated with the hot water storage cylinder. It contains a neoprene diaphragm to separate water from air, the air providing a 'cushion' for the expansion of hot water. Air loss can be replenished by foot pump as required.

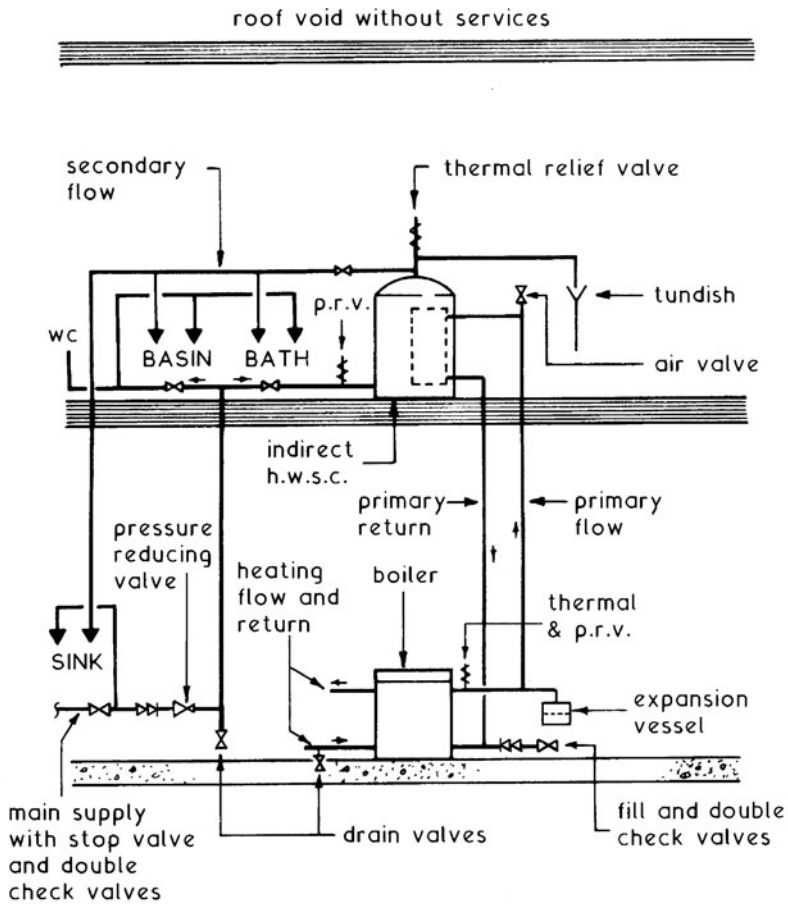

NB. p.r.v. = pressure relief (safety) valve.

Temperatures ~

Boiler flow and return, approximately 80°C and 70°C respectively.

Stored hot water, 60°C to 65°C (not less than 60°C).

Distributed hot water, not less than 55°C.

Supply to outlets, approximately 50°C.

## Hot Water System Temperatures

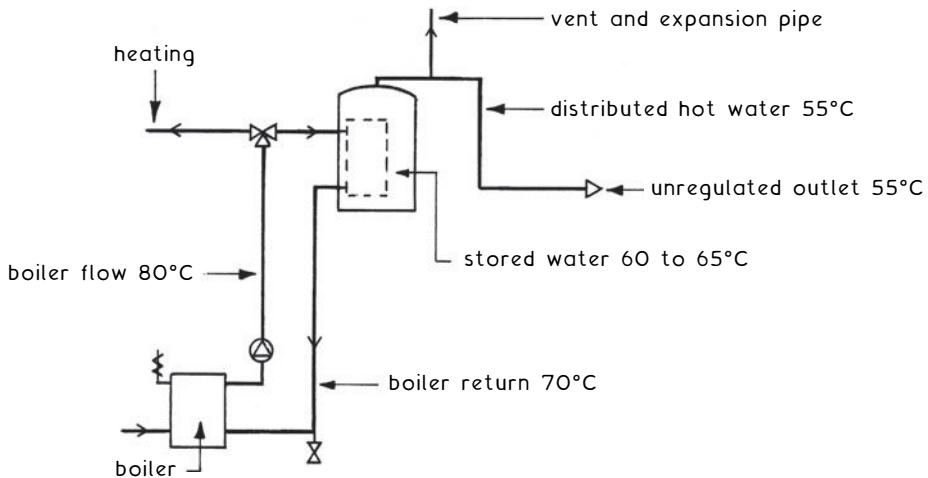

High temperatures are necessary to prevent the development of waterborne pathogens such as legionella pneumophila. Known generally as legionnaires' disease, this deadly bacterial infection was named after numerous American military veterans attending a reunion at a hotel in Philadelphia in 1976 died from exposure to the contaminated water system. There have subsequently been many more outbreaks throughout the world with similar consequences. Organisms are most prevalent in aquatic environments maintained at temperatures between 25°C and 45°C. This includes undisinfected water in air conditioning systems, fountains, humidifiers, jacuzzis and any other situation producing suspended moisture droplets.

Ref. Water Supply (Water Fittings) Regulations.



## Hot Water Installations – Thermostatic Mixing Valves

Hot Water Outlet Temperature ~ at 50°C scalding is unlikely for most people, but there is a risk where appliances are used by young children, the elderly and those with loss of sensory perception.

Safe hot water outlet temperatures ~

- Bath 43°C
- Shower 40°C
- Wash basin 40°C
- Bidet 37°C
- Sink 48°C

Application ~ new-build and existing buildings that are subject to change of use, or alterations that involve installation of new bathroom facilities.

Installation ~ thermostatic mixing valves (similar to shower mixers) are required as close as possible to the hot water outlet to control water temperature. These can be manually set to blend the hot and cold water supplies at a fixed discharge temperature. These valves contain an automated fast shutdown facility in the event of a supply failure.

Typical Installation ~

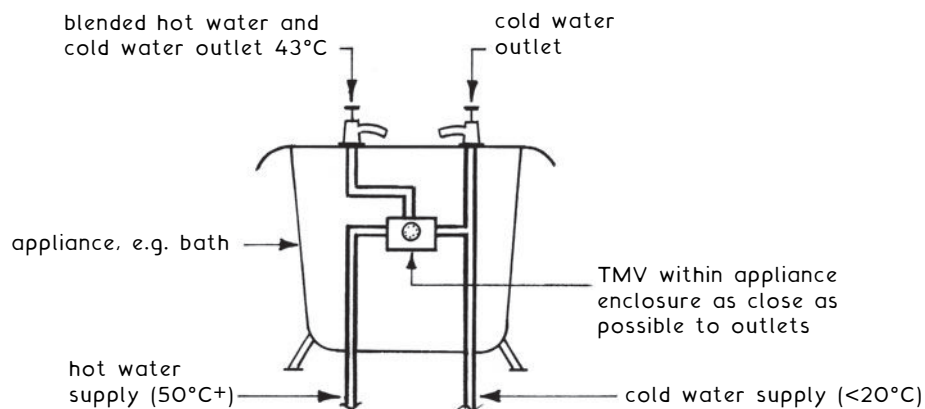

Refs.: Building Regulations, Approved Document G3: Hot water supply and systems.

BS EN 1111: Sanitary tapware, thermostatic mixing valves (PN 10). General technical specification.

BS EN 1287: Sanitary tapware, low pressure thermostatic mixing valves. General technical specification.

Flow Controls ~ these are valves inserted into a water installation to control the water flow along the pipes or to isolate a branch circuit or to control the draw-off of water from the system.

Typical Examples ~

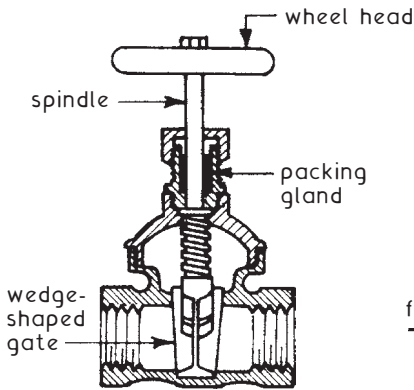

**GATE VALVE**  
low pressure cistern supply

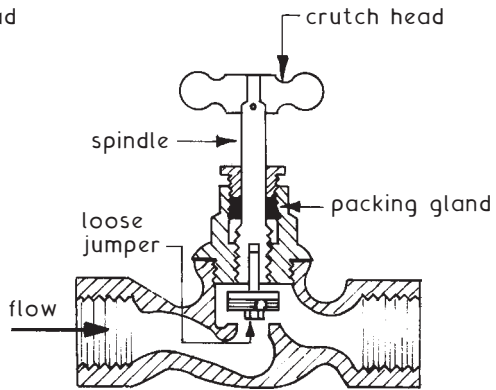

**STOP VALVE**  
high pressure mains supply

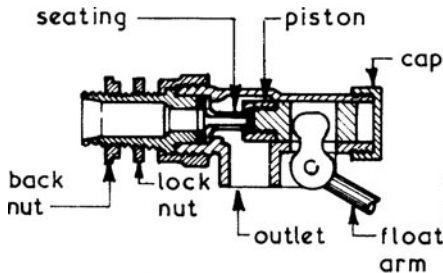

**PORTSMOUTH FLOATVALVE**

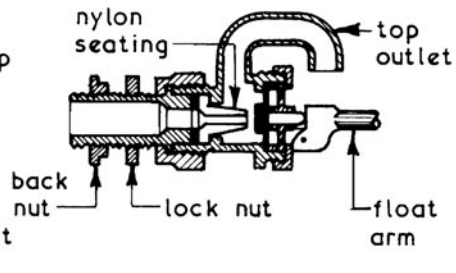

**DIAPHRAGM FLOATVALVE**

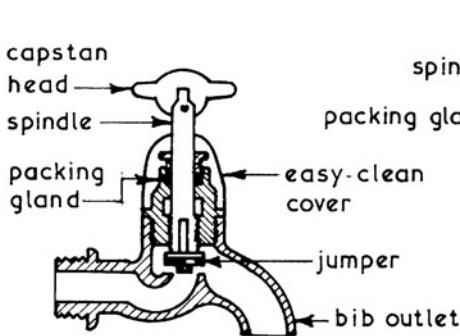

**BIB TAP**  
horizontal inlet - used over  
sinks and for hose-pipe outlets

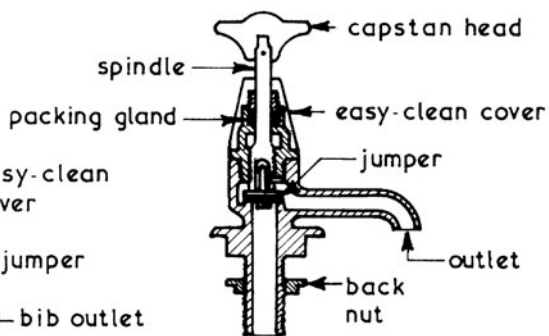

**PILLAR TAP**  
vertical inlet - used in  
conjunction with fittings

## Hot and Cold Water Installations – Cisterns

Cisterns ~ these are fixed containers used for storing water at atmospheric pressure. The inflow of water is controlled by a floatvalve which is adjusted to shut off the water supply when it has reached the designed level within the cistern. The capacity of the cistern depends on the draw-off demand and whether the cistern feeds both hot and cold water systems. Domestic cold water cisterns should be placed at least 750mm away from an external wall or roof surface and in such a position that it can be inspected, cleaned and maintained. A minimum clear space of 350mm is required over the cistern for floatvalve maintenance. An overflow or warning pipe of not less than 22mm diameter must be fitted to fall away to discharge in a conspicuous position. All draw-off pipes must be fitted with a gate valve positioned as near to the cistern as possible.

Cisterns are available in a variety of sizes and materials such as galvanised mild steel (BS 417-2), moulded plastic (BS 4213) and reinforced plastic (BS EN 13121 and 13280). If the cistern and its associated pipework are to be housed in a cold area such as a roof they should be insulated against freezing.

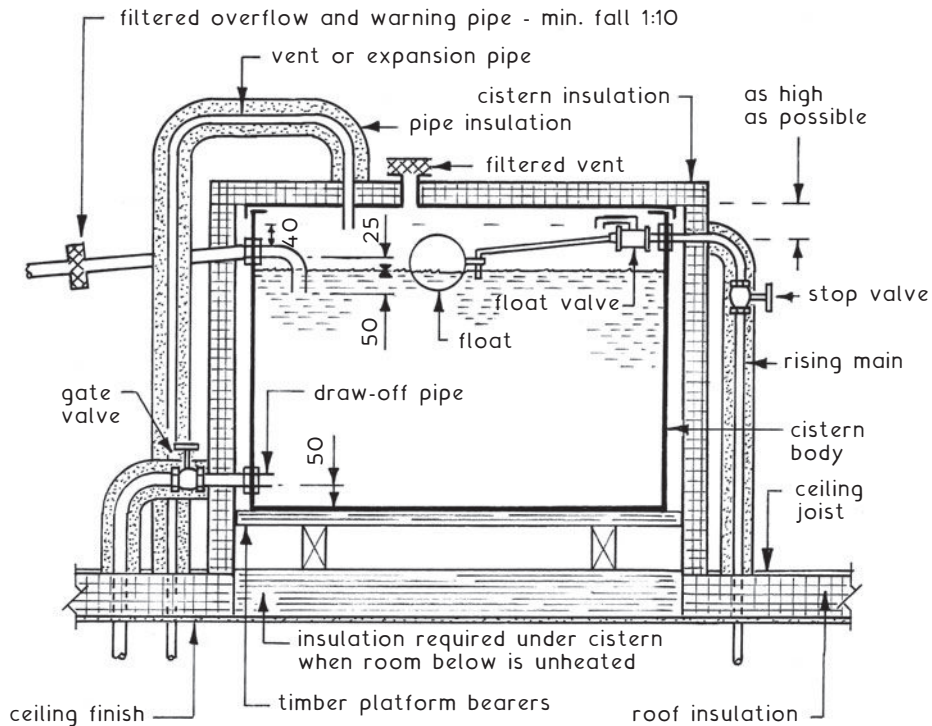

Indirect Hot Water Cylinders ~ these cylinders are a form of heat exchanger where the primary circuit of hot water from the boiler flows through a coil or annulus within the storage vessel and transfers the heat to the water stored within. An alternative hot water cylinder for small installations is the single feed or 'Primatic' cylinder which is self-venting and relies on two airlocks to separate the primary water from the secondary water. This form of cylinder is connected to pipework in the same manner as for a direct system (see page 896) and therefore gives savings in both pipework and fittings. Indirect cylinders usually conform to the recommendations of BS 417-2 (galvanised mild steel) or BS 1566-1 (copper). Primatic or single-feed cylinders to BS 1566-2 (copper).

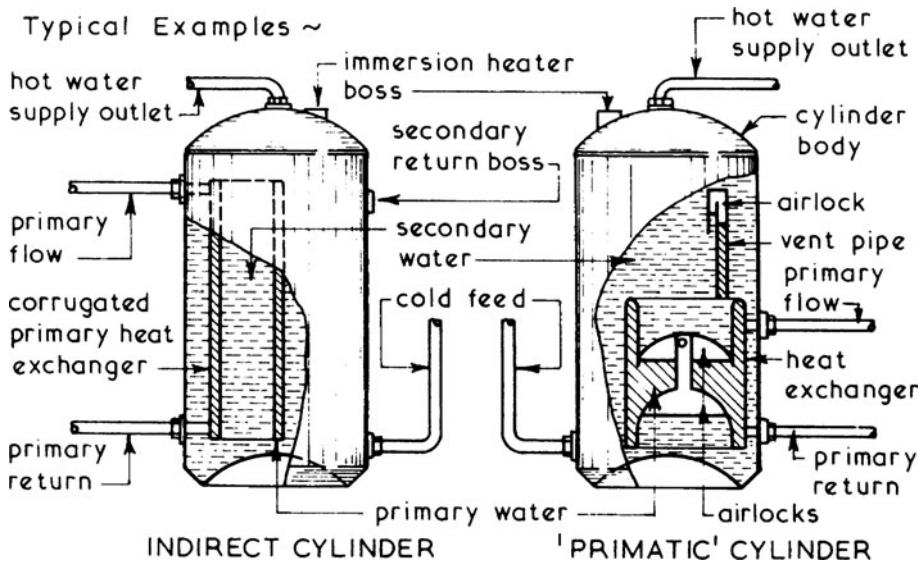

## Primatic Cylinders:

1. Cylinder is filled in the normal way and the primary system is filled via the heat exchanger, as the initial filling continues airlocks are formed in the upper and lower chambers of the heat exchanger and in the vent pipe.
2. The two airlocks in the heat exchanger are permanently maintained and are self-recuperating in operation. These airlocks isolate the primary water from the secondary water almost as effectively as a mechanical barrier.
3. The expansion volume of total primary water at a flow temperature of  $82^{\circ}\text{C}$  is approximately  $1/25$  and is accommodated in the upper expansion chamber by displacing air into the lower chamber; upon contraction reverse occurs.

# Water Installations – Pipework Joints

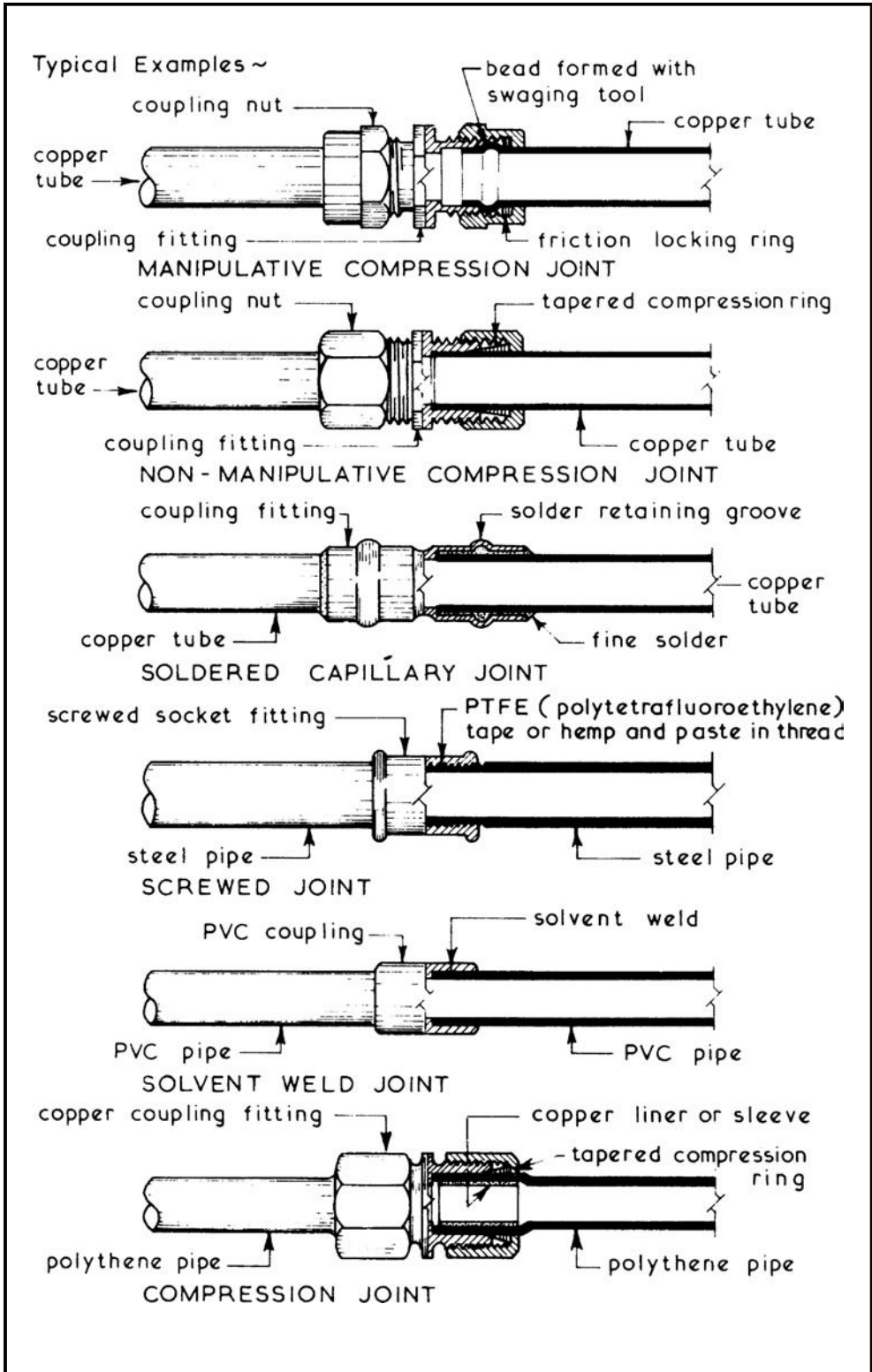

Typical Examples ~

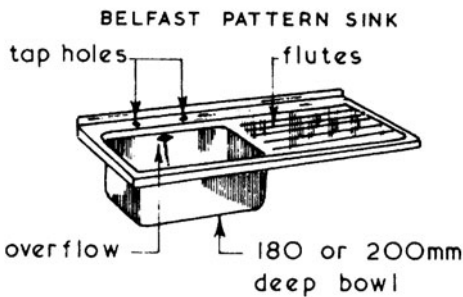
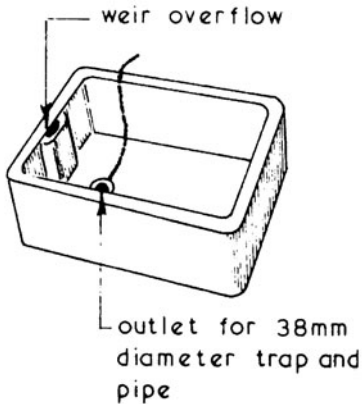

SINGLE DRAINER STAINLESS STEEL SINK

Fireclay Sinks (BS 1206) – these are white glazed sinks and are available in a wide range of sizes from 460 x 380 x 200 deep up to 1220 x 610 x 305 deep and can be obtained with an integral drainer. They should be fixed at a height between 850 and 920mm and supported by legs, cantilever brackets or dwarf brick walls.

Metal Sinks (BS EN 13310) – these can be made of enamelled pressed steel or stainless steel with single or double drainers in sizes ranging from 1070 x 460 to 1600 x 530 supported on cantilever brackets or sink cupboards.

Ceramic Wash Basins (BS1188)

fixing height  
790 mm

bowl – depth  
165 mm

plan size  
457 x 653 mm

pedestal support

38 or 78 mm  
seal trap

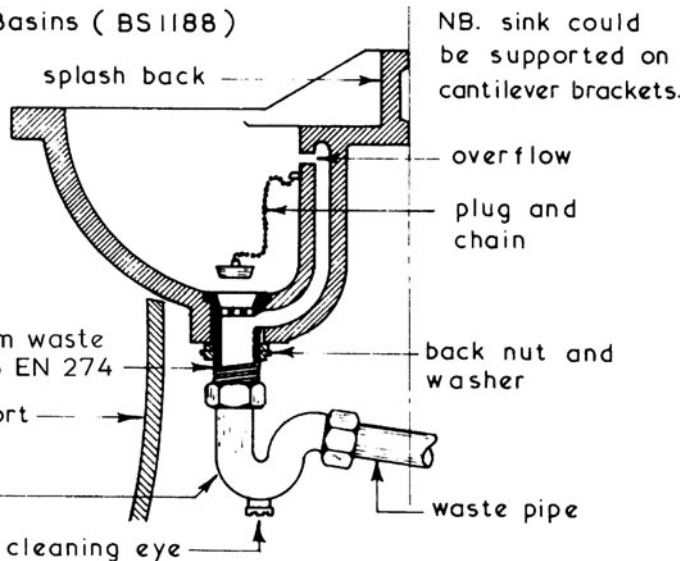

# Sanitary Fittings – Baths and Showers

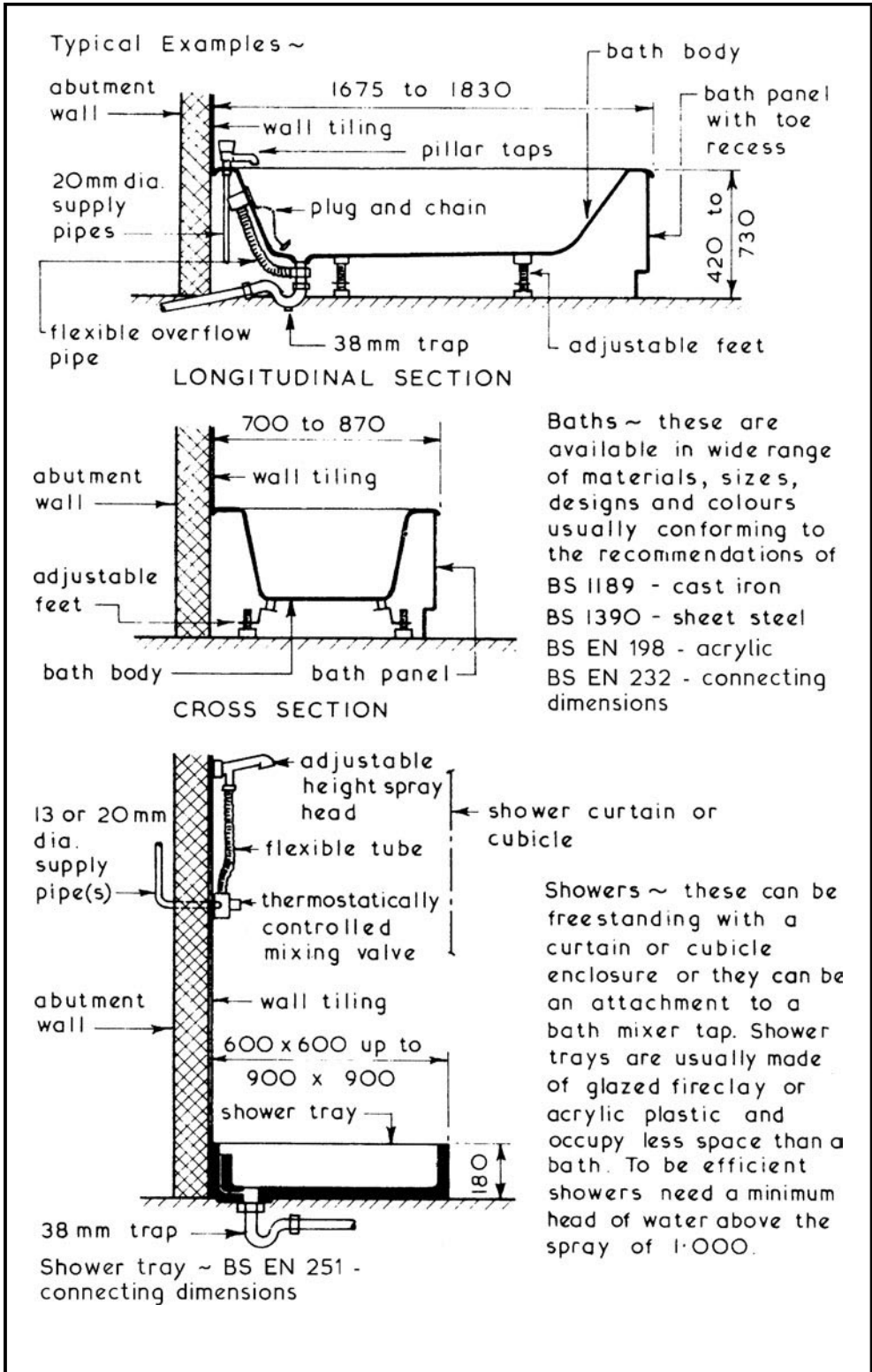

Typical Examples ~

Wash-down Water Closet - BS EN 33 ~  
common type which relies on flush of  
water to remove contents of bowl.  
Horizontal outlet now standard.

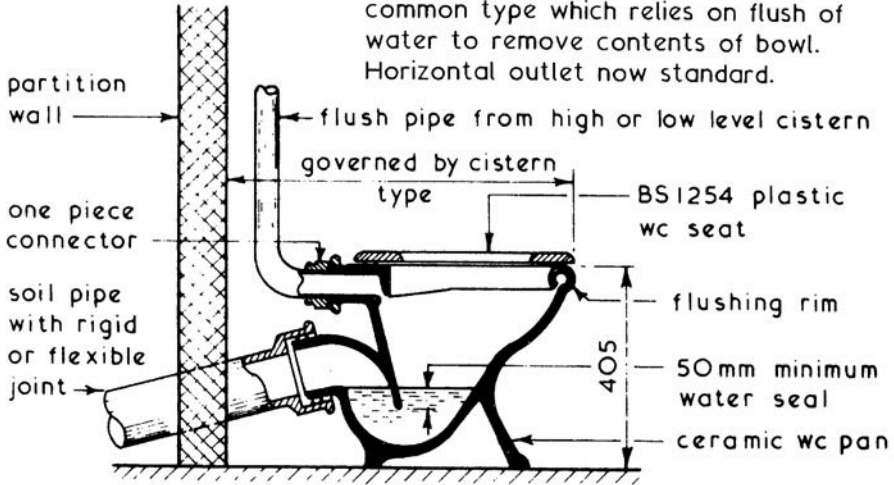

Siphonic Water Closets ~ efficient  
and quiet in operation but higher  
risk of blockage if misused - can be  
single or double trap format.

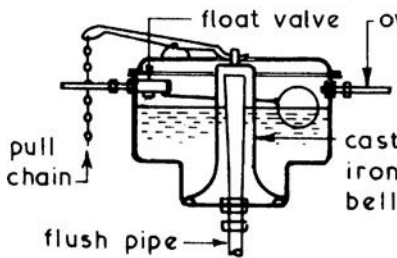
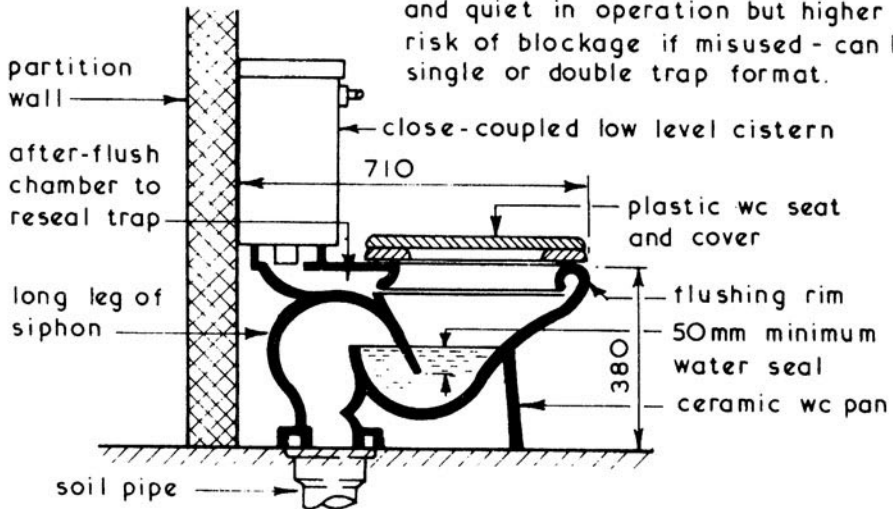

**HIGH LEVEL BELL-TYPE CISTERN**  
(obsolete, but many remain in use)

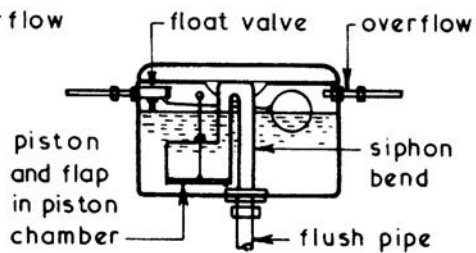

**LOW LEVEL PISTON CISTERN**  
(6/4 litre dual flush to BS 1125)



# Single Stack Discharge Systems

Single Stack System ~ method developed by the Building Research Establishment to eliminate the need for ventilating pipework to maintain the water seals in traps to sanitary fittings. The slope and distance of the branch connections must be kept within the design limitations given below. This system is only possible when the sanitary appliances are closely grouped around the discharge stack.

## Typical Details ~

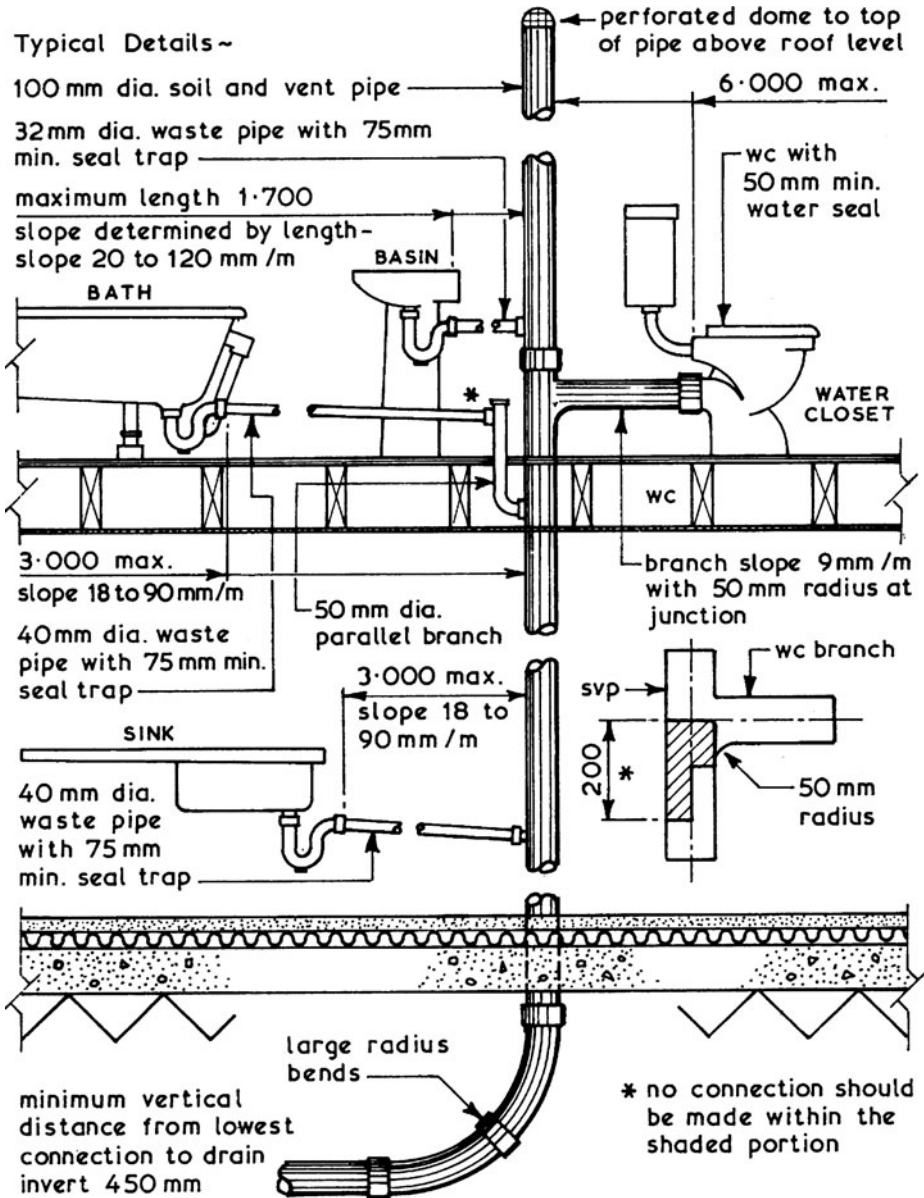

Ventilated Stack Systems ~ where the layout of sanitary appliances is such that they do not conform to the requirements for the single stack system shown on the previous page ventilating pipes will be required to maintain the water seals in the traps. Three methods are available to overcome the problem, namely a fully ventilated system, a ventilated stack system and a modified single stack system which can be applied over any number of storeys.

## Typical Examples ~

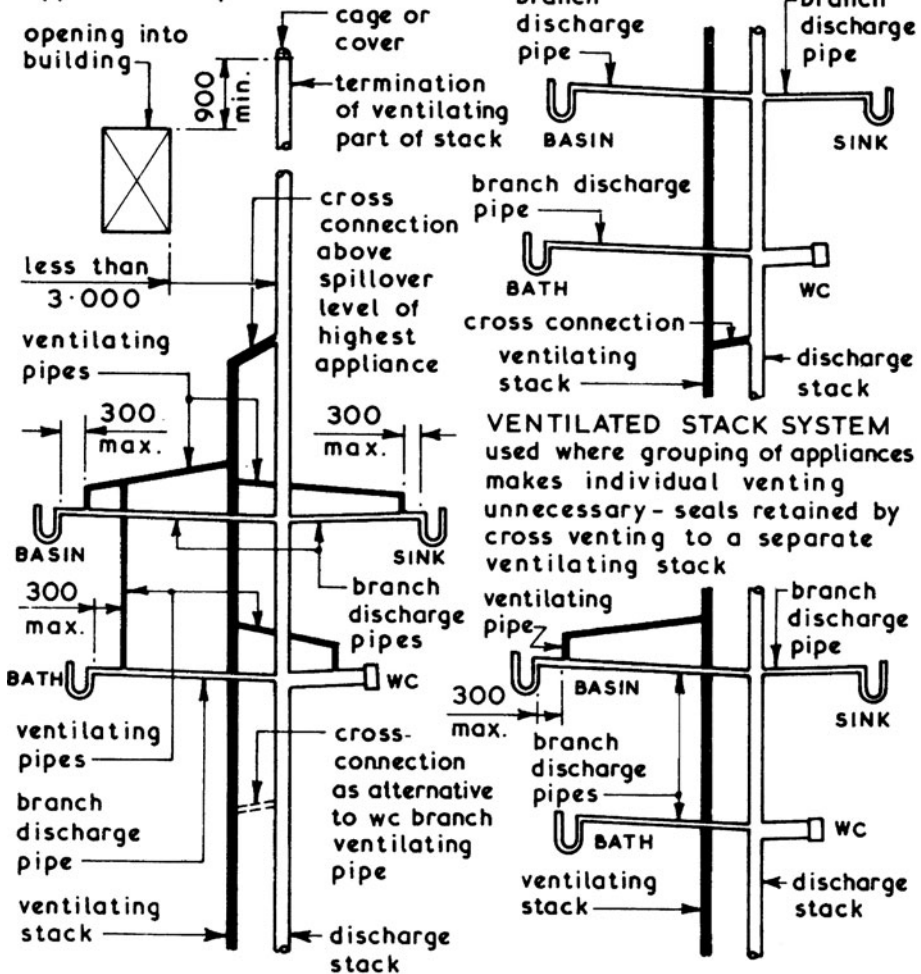

### FULLY VENTILATED SYSTEM

used where there are a large number of appliances which are widely dispersed or grouped in ranges

Minimum diameter for branch ventilating pipes = 25mm.

### MODIFIED SINGLE STACK SYSTEM

used to ventilate only those branch pipes exceeding length required for a single stack system

## Air Admittance Valve

Air Admittance Valve (AAV) ~ also known as a Durgo valve. A pressure-sensitive device fitted at the top of a discharge stack.

Location ~ above the highest possible flood level of the uppermost appliance connected to the stack, usually the wash basin. For accessible maintenance and testing, an AAV is positioned within the ventilated roof space. Unsightly stack ventilation above a roof is eliminated, with savings in pipe installation time and weathering the stack to the roof covering.

Application ~ up to four dwellings of one-, two- or three-storey height, the fifth to be conventionally vented at the highest part of the drain serving all five dwellings. AAVs are not suitable for older installations where an interceptor trap is used on the drain to each dwelling and/or where the stack discharges to a cesspool or septic tank. For higher rise buildings the use of AAVs is also limited. For instance, they should not be used if periodic surcharging occurs or where more than one building is connected to a common drain. AAV manufacturers should be consulted for specific situations.

AAV closed

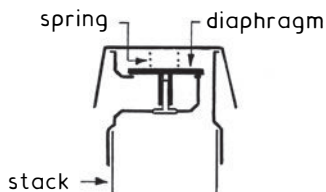

AAV open

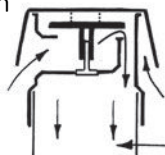

negative pressure during appliance discharge

AAV in roof space up to four dwellings if fifth dwelling conventionally vented

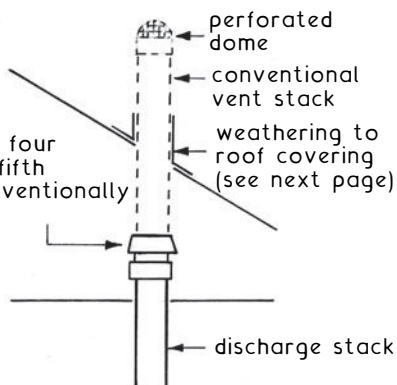

Refs.: Building Regulations A.D. H1: Foul water drainage.

BS EN 12056-2: Gravity drainage systems inside buildings.

BS EN 12380: AAVs for drainage systems.

## Ventilating Stack – Weathering

Lead slate ~ so-named as originally designed to fit with the courses of slate-covered roofs. Sheet lead is sufficiently adaptable to be cut and welded into purpose-made flashings to suit various tile profiles, roof slopes and stack diameters. Overall size is determined by the type and size of the tile or sheet roof covering. E.g. where used with plain tiling and a 100mm nominal diameter stack, a width of about 400mm wide and depth of about 450mm is sufficient, with a 100mm upstand at the back.

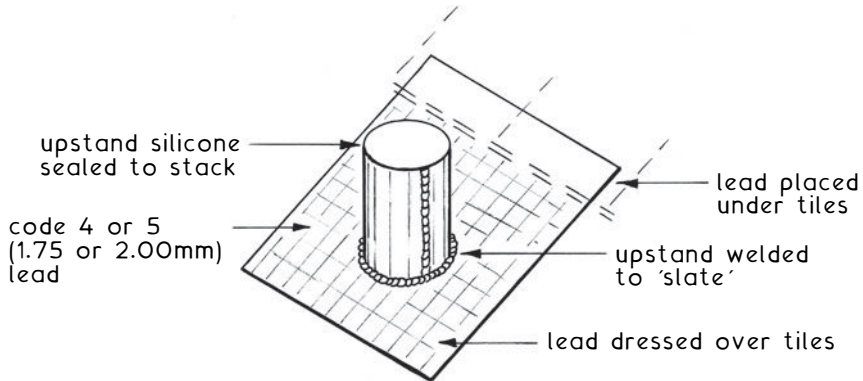

Fabricated vent pipe flashing ~ an off-the-shelf, one-fits-all ventilating stack pipe weathering, otherwise known as a flashing boot. Factory manufactured from flexible aluminium sheet with a moulded rubber sleeve located into a central hole through which the pipe is fitted. The rubber is sufficiently flexible to adapt to various roof pitches and to maintain a watertight seal to the stack.

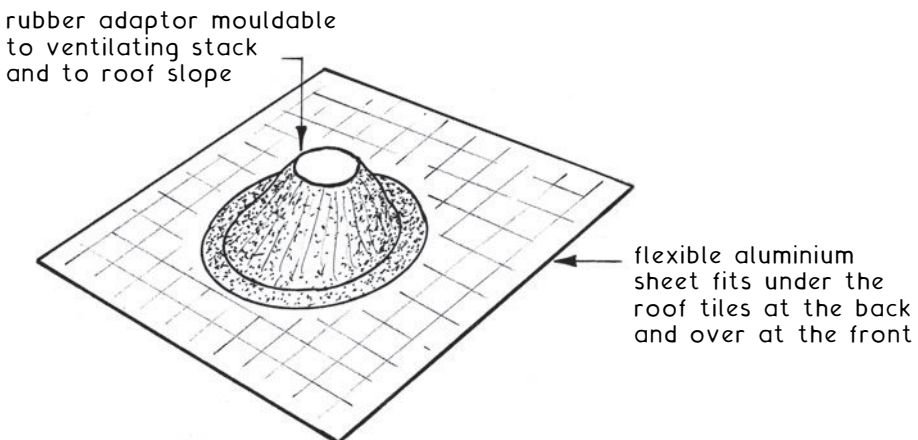

## Sanitation Systems – Testing

Airtightness ~ must be ensured to satisfy public health legislation. The Building Regulations, Approved Document H1: Section 1, provides minimum standards for test procedures. An air or smoke test on the stack must produce a pressure at least equal to 38mm water gauge for not less than three minutes.

Application ~

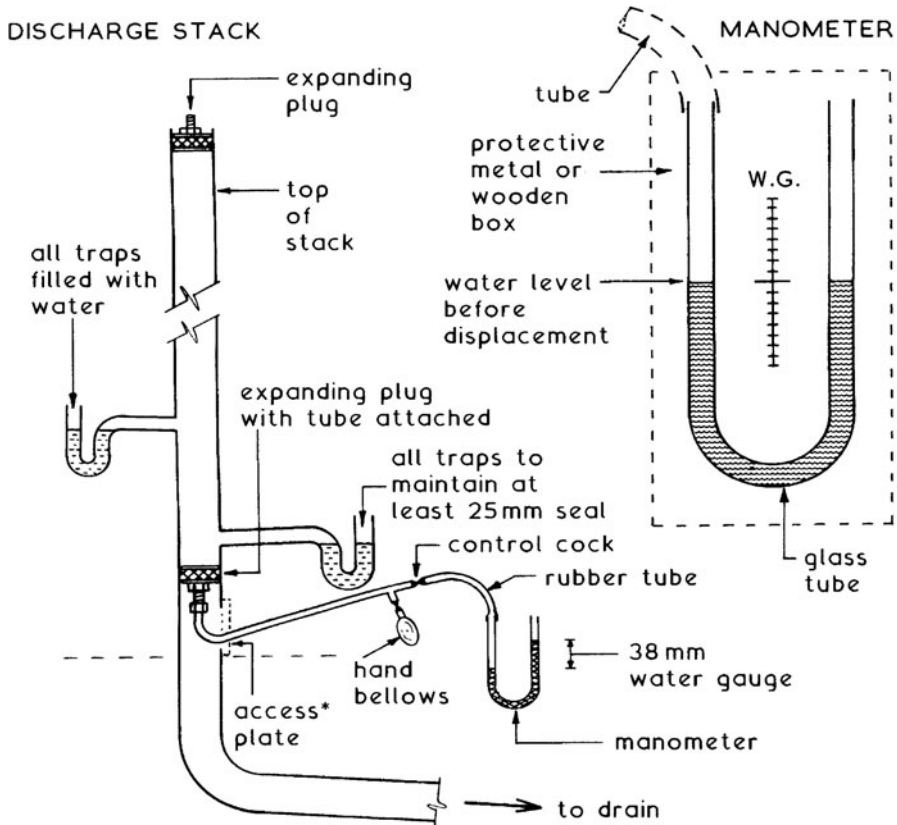

\* if access plate is not provided, top connection to first IC may be plugged and rubber tube inserted through wc pan seal.

NB. Smoke tests are rarely applied now as the equipment is quite bulky and unsuited for use with uPVC pipes. Smoke-producing pellets are ideal for leakage detection, but must not come into direct contact with plastic materials.

One Pipe System ~ the hot water is circulated around the system by means of a centrifugal pump, the flow pipe temperature being about 80°C and the return pipe temperature being about 60 to 70°C. The one pipe system is simple in concept and easy to install but has the main disadvantage that the hot water passing through each heat emitter flows onto the next heat emitter or radiator, therefore the average temperature of successive radiators is reduced unless the radiators are carefully balanced or the size of the radiators at the end of the circuit is increased to compensate for the temperature drop.

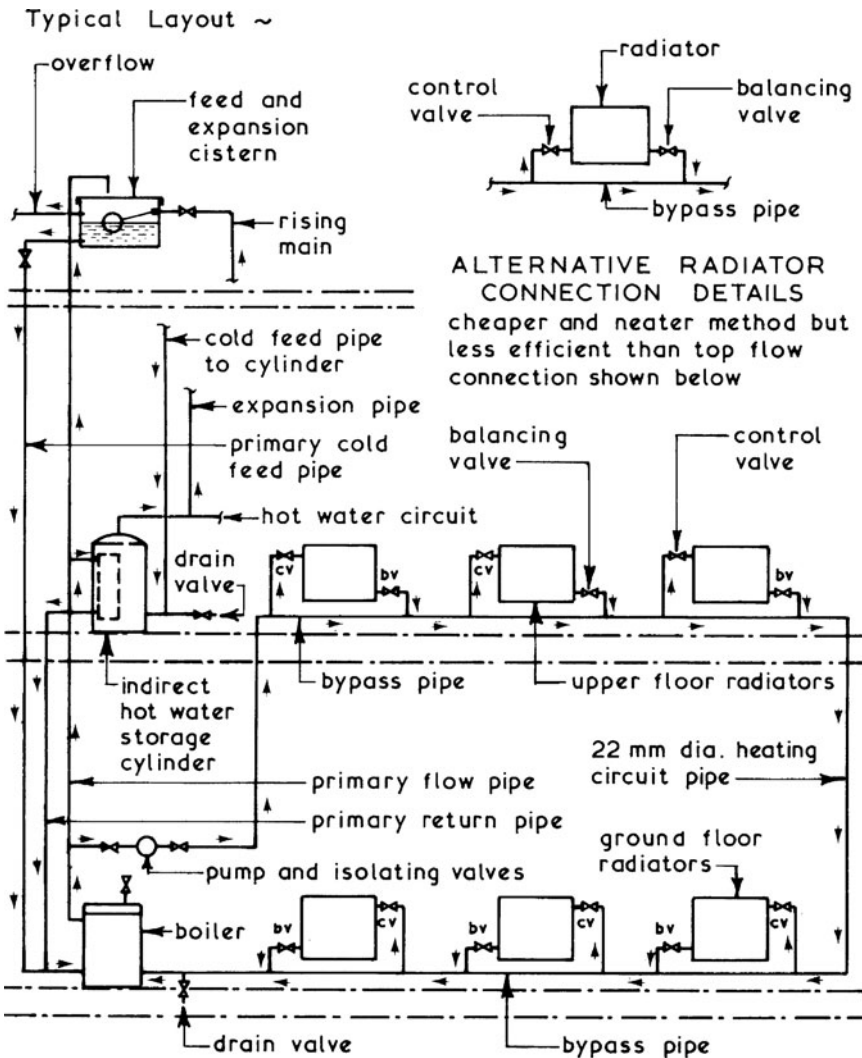

# Hot Water Heating Systems

Two Pipe System ~ this is a dearer but much more efficient system than the one pipe system shown on the previous page. It is easier to balance since each radiator or heat emitter receives hot water at approximately the same temperature because the hot water leaving the radiator is returned to the boiler via the return pipe without passing through another radiator.

Typical Layout ~

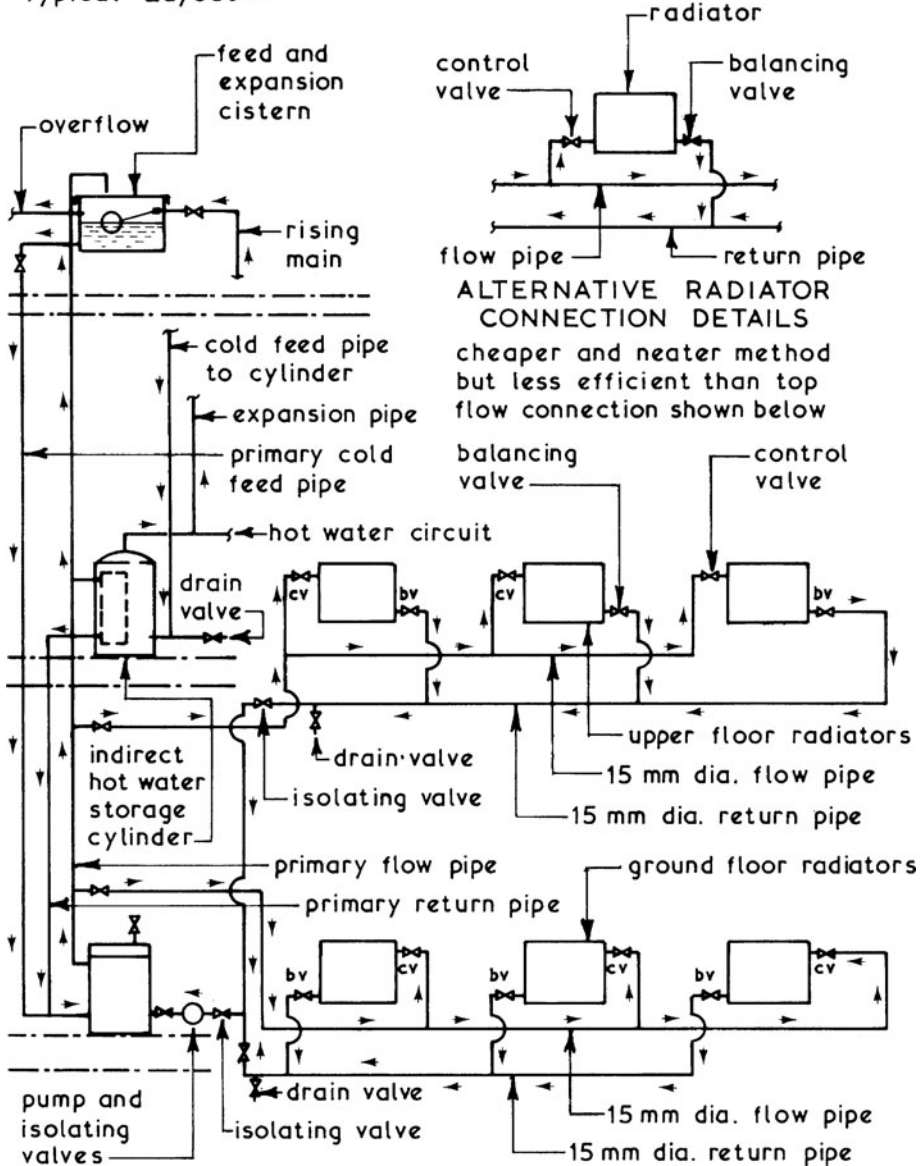

Micro Bore System ~ this system uses 6 to 12mm diameter soft copper tubing with an individual flow and return pipe to each heat emitter or radiator from a 22mm diameter manifold. The flexible and unobstrusive pipework makes this system easy to install in awkward situations but it requires a more powerful pump than that used in the traditional small bore systems. The heat emitter or radiator valves can be as used for the one or two pipe small bore systems; alternatively a double entry valve can be used.

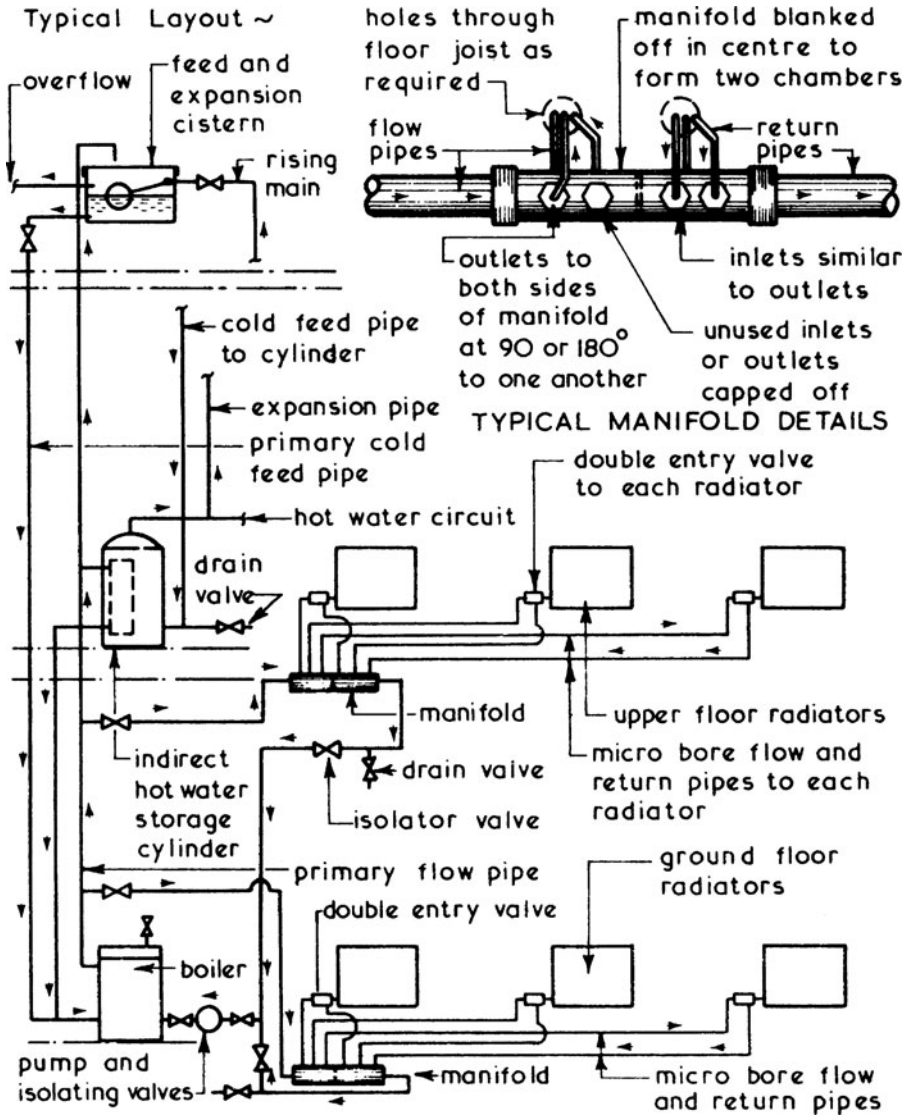



# Hot Water Heating Systems

Controls ~ the range of controls available to regulate the heat output and timing operations for a domestic hot water heating system is considerable, ranging from thermostatic radiator control valves to programmers and controllers.

Typical Example ~

Boiler - fitted with a thermostat to control the temperature of the hot water leaving the boiler.

Heat Emitters or Radiators - fitted with thermostatically controlled radiator valves to control flow of hot water to the radiators to keep room at desired temperature.

Programmer/Controller - this is basically a time switch which can usually be set for 24 hours at once-daily or twice-daily time periods and will generally give separate programme control for the hot water supply and central heating systems. The hot water cylinder and room thermostatic switches control the pump and motorised valve action.

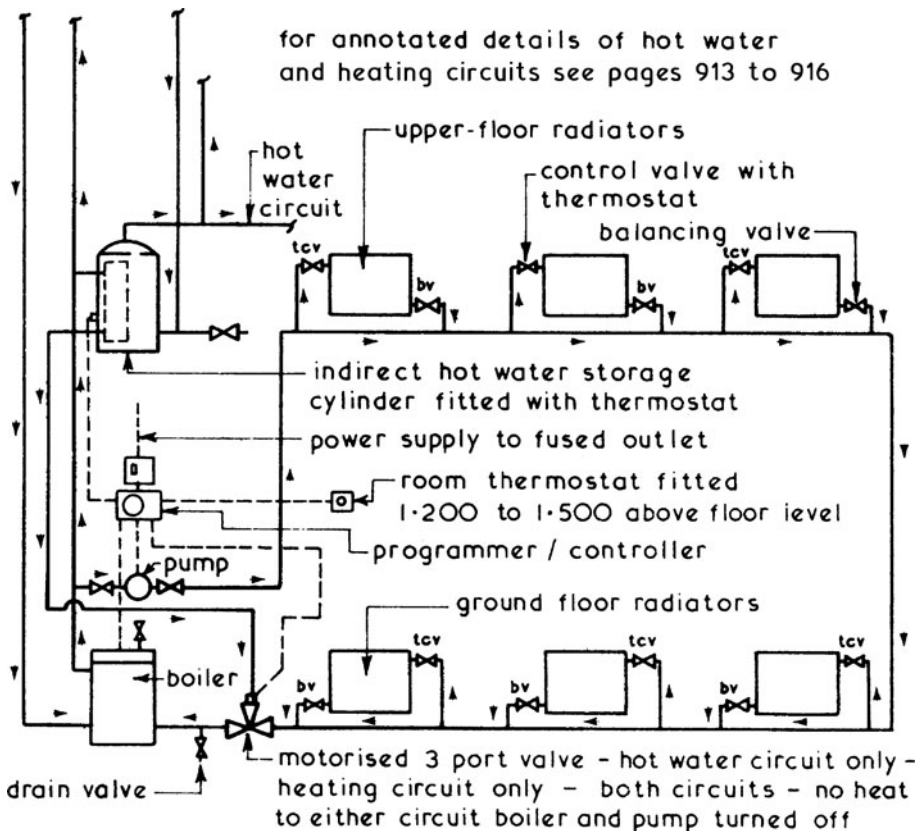

Electrical Supply ~ in the UK electricity is generated mainly from gas, coal, nuclear and hydro-electricity power plants. Alternative energy generation such as wind and solar power is also viable and considered in Part 16 of the *Building Services Handbook*. Distribution is through regional companies. The electrical supply to a domestic installation is usually 230 volt single phase and is designed with the following safety objectives:

1. Proper circuit protection to earth to avoid shocks to occupant.
2. Prevention of current leakage.
3. Prevention of outbreak of fire.

## Typical Electrical Supply Intake Details ~

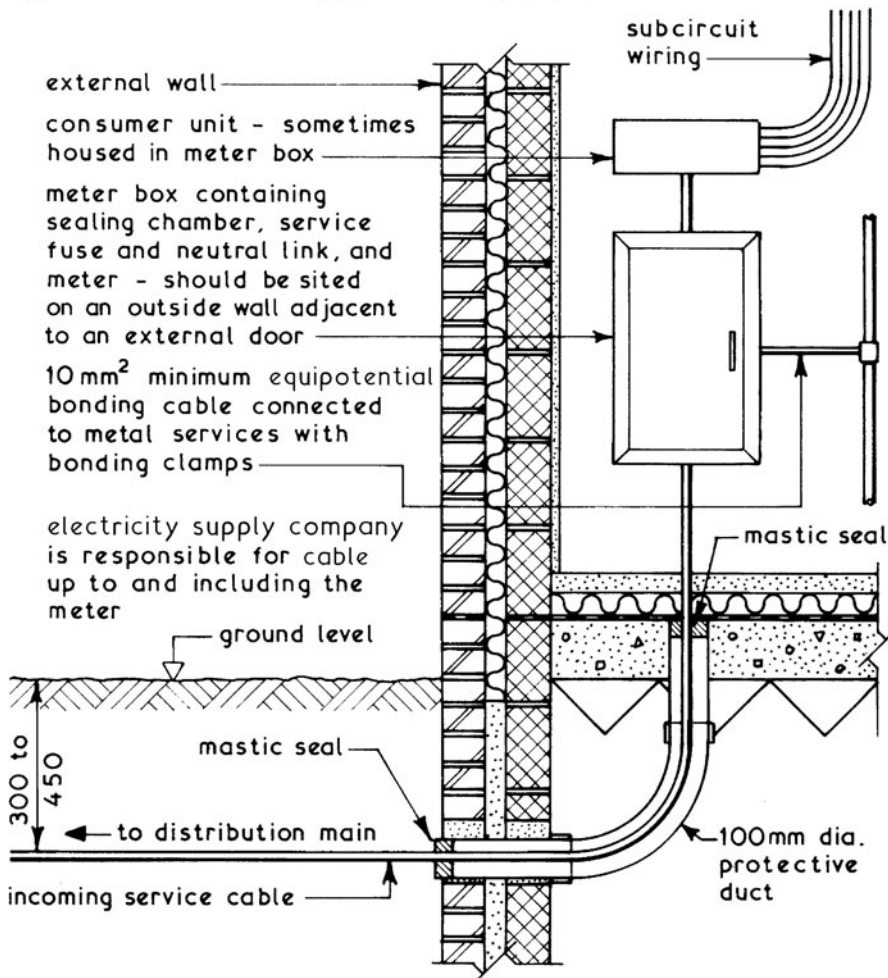

NB. For alternative arrangement of supply intake see following page.

## Electrical Supply – Basic Requirements

Electrical Supply Intake ~ although the electrical supply intake can be terminated in a meter box situated within a dwelling, most supply companies prefer to use the external meter box to enable the meter to be read without the need to enter the premises.

### Typical Electrical Supply Intake Details ~

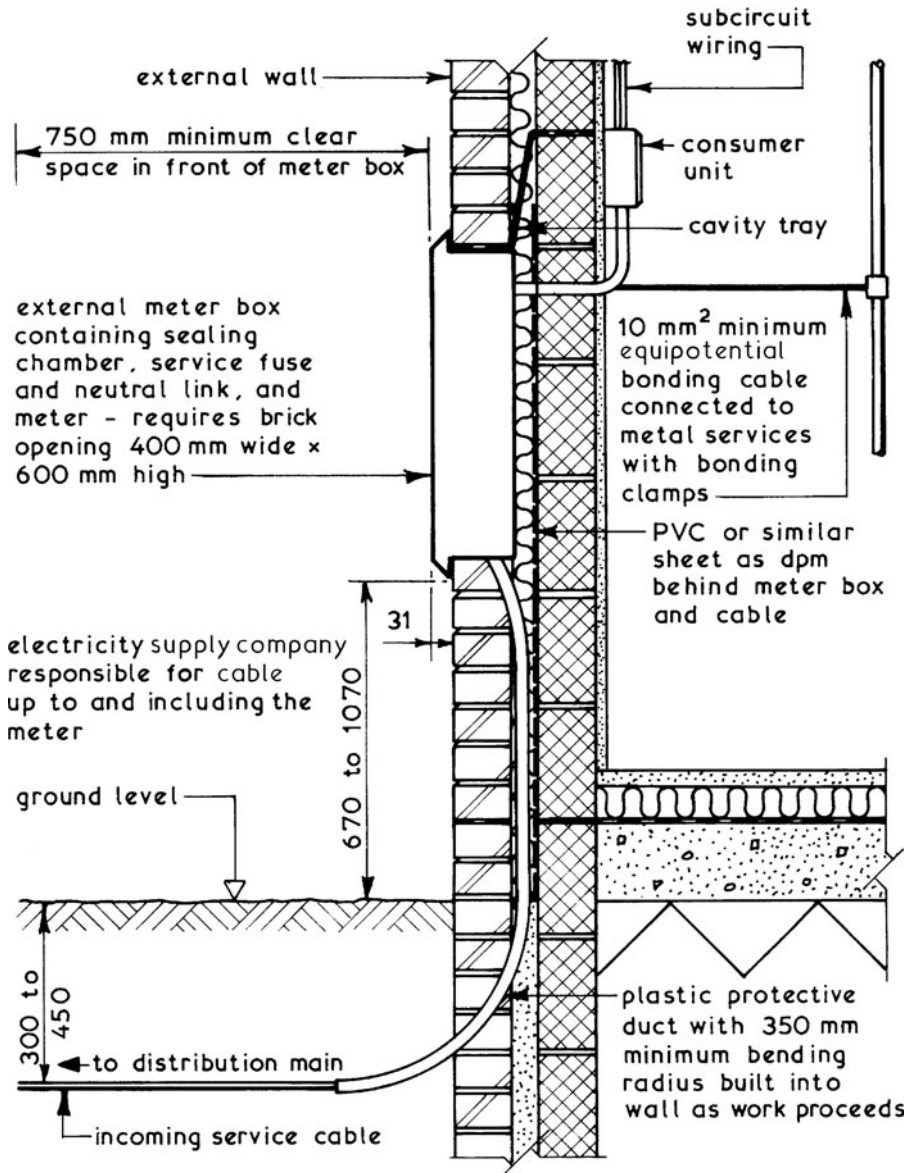

NB. For alternative arrangement of supply intake see previous page.

Entry and Intake of Electrical Service ~ the local electricity supply company is responsible for providing electricity up to and including the meter, but the consumer is responsible for safety and protection of the company's equipment. The supplier will install the service cable up to the meter position where their termination equipment is installed. This equipment may be located internally or fixed externally on a wall, the latter being preferred since it gives easy access for reading the meter – see details on the previous page.

Meter Boxes - generally the supply company's meters and termination equipment are housed in a meter box. These are available in fibreglass and plastic, ranging in size from 450mm wide x 638mm high to 585mm wide x 815mm high with an overall depth of 177mm.

Consumer Control Unit - this provides a uniform, compact and effective means of efficiently controlling and distributing electrical energy within a dwelling. The control unit contains a main double pole isolating switch controlling the line and neutral conductors, called bus bars. These connect to the fuses or miniature circuit breakers protecting the final subcircuits.

Typical Layout ~

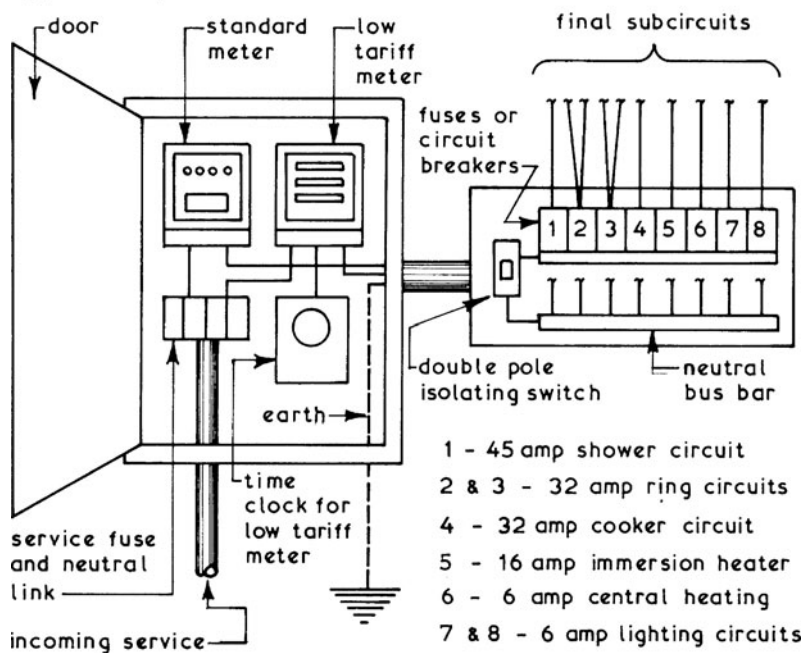

## Electrical Supply – Consumer Unit

Consumer's Power Supply Control Unit – this is conveniently abbreviated to consumer unit. As described on the previous page, it contains a supply isolator switch, live, neutral and earth bars, plus a range of individual circuit overload safety protection devices. By historical reference this unit is sometimes referred to as a fuse box, but modern variants are far more sophisticated. Overload protection is provided by miniature circuit breakers attached to the live or phase bar. Additional protection is provided by a split load residual current device (RCD) dedicated specifically to any circuits that could be used as a supply to equipment outdoors, e.g. power sockets on a ground floor ring final circuit.

RCD – a type of electromagnetic switch or solenoid which disconnects the electricity supply when a surge of current or earth fault occurs. See Part 11 of the *Building Services Handbook* for more details.

### Typical Split Load Consumer Unit –

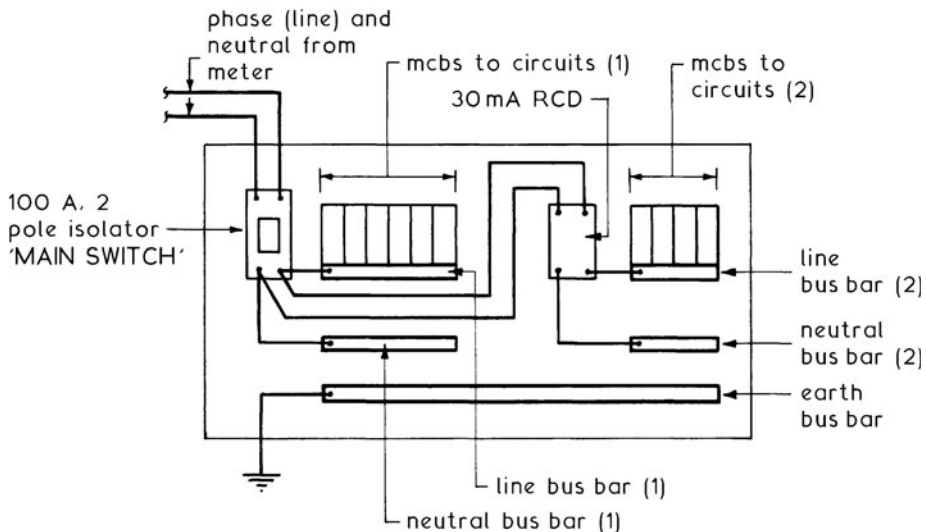

Note that with an overhead supply, the MAIN SWITCH is combined with a 100mA RCD protecting all circuits.

#### Notes:

Circuits (1) to fixtures, i.e. lights, cooker, immersion heater and smoke alarms.

Circuits (2) to socket outlets that could supply portable equipment outdoors.

Electric Cables ~ these are made up of copper or aluminium wires called conductors surrounded by an insulating material such as PVC or rubber.

Typical Examples ~

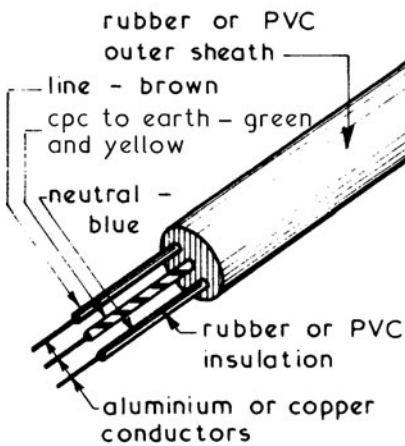

SHEATHED CABLES

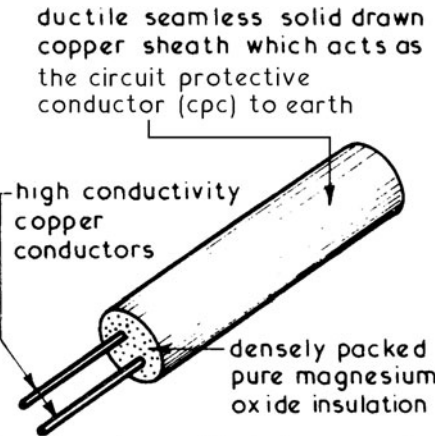

NB. magnesium oxide is hygroscopic; therefore ends of cable must be fitted with special sealing pots.

MINERAL INSULATED CABLE

Conduits ~ these are steel or plastic tubes which protect the cables. Steel conduits act as a cpc to earth whereas plastic conduits will require a separate cpc drawn in. Conduits enable a system to be rewired without damage or interference to the fabric of the building. The cables used within conduits are usually insulated only, whereas in non-rewirable systems the cables have a protective outer sheath.

Typical Conduit Fittings ~

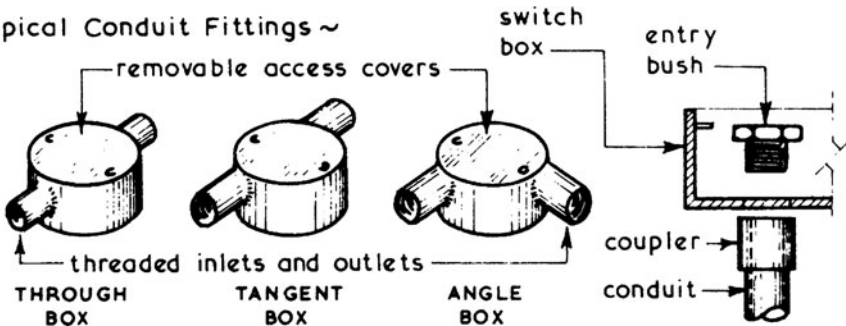

Trunking - alternative to conduit and consists of a preformed cable carrier which is surface mounted and is fitted with a removable or 'snap-on' cover which can have the dual function of protection and trim or surface finish.

# Electrical Installations

Wiring Systems ~ rewirable systems housed in horizontal conduits can be cast into the structural floor slab or sited within the depth of the floor screed. To ensure that such a system is rewirable, draw-in boxes must be incorporated at regular intervals and not more than two right angle boxes to be included between draw-in points. Vertical conduits can be surface mounted or housed in a chase cut into a wall provided the depth of the chase is not more than one-third of the wall thickness. A horizontal non-rewirable system can be housed within the depth of the timber joists to a suspended floor whereas vertical cables can be surface mounted or housed in a length of conduit as described for rewirable systems.

## Typical Examples ~

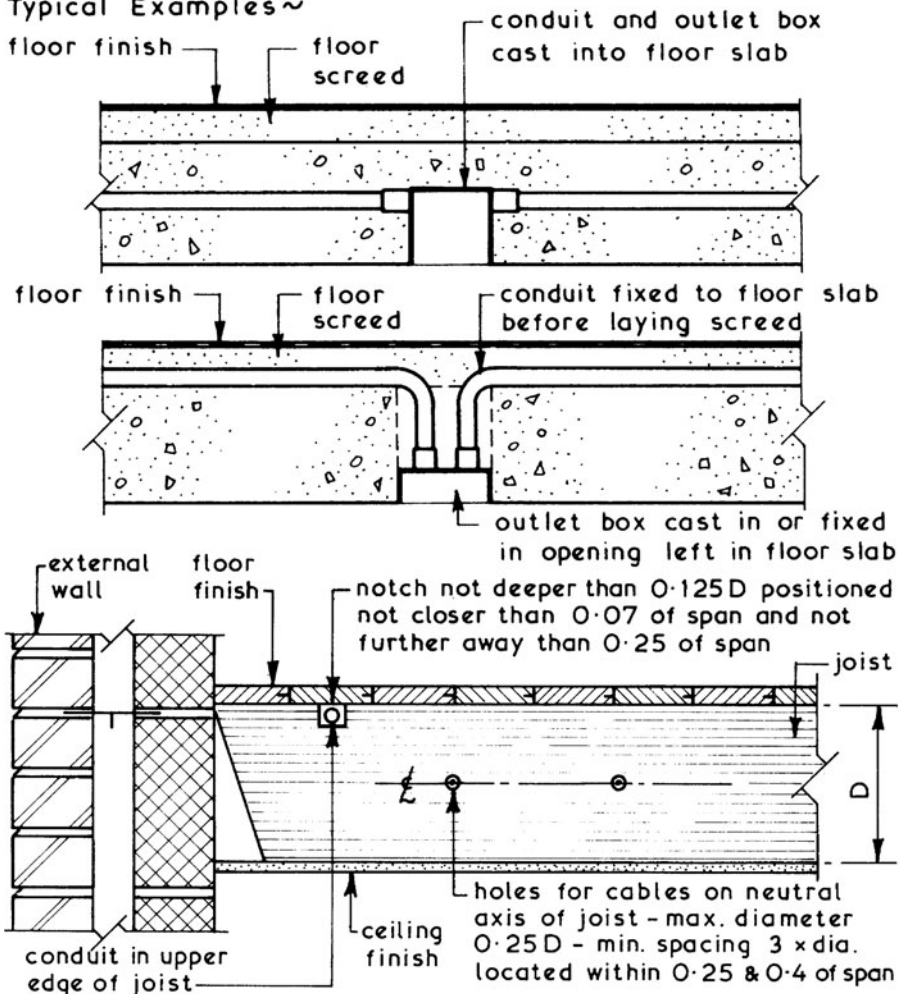

Cable Sizing ~ the size of a conductor wire can be calculated taking into account the maximum current the conductor will have to carry (which is limited by the heating effect caused by the resistance to the flow of electricity through the conductor) and the voltage drop which will occur when the current is carried. For domestic electrical installations the following minimum cable specifications are usually suitable:

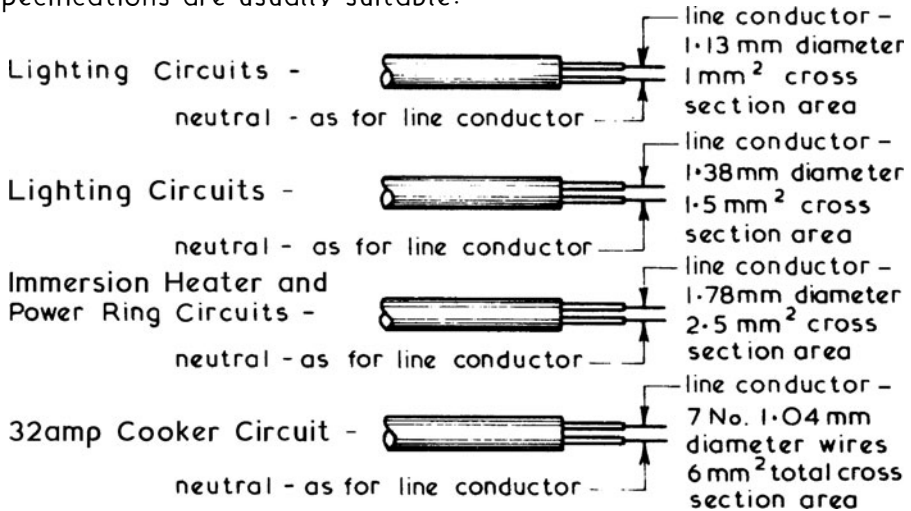

All the above ratings are for the line and neutral conductors which will be supplemented with a circuit protective conductor as shown on page 921.

Electrical Accessories ~ for power circuits these include cooker control units and fused switch units for fixed appliances such as immersion heaters, water heaters and central heating controls.

Socket Outlets ~ these may be single or double outlets, switched or unswitched, surface or flush mounted and may be fitted with indicator lights. Recommended fixing heights are:

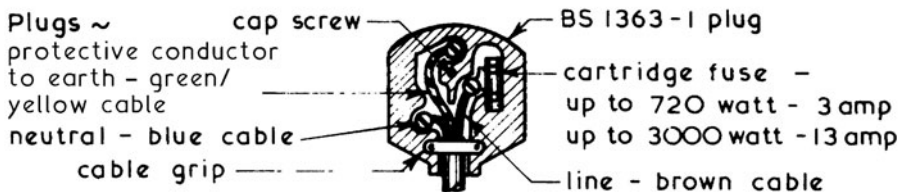
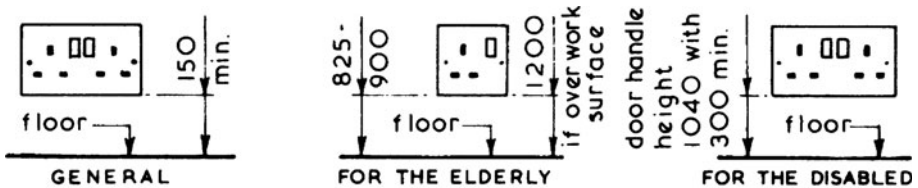



# Electrical Installations

Power Sockets ~ in new domestic electrical installations the ring final circuit is usually employed instead of the older obsolete radial system where socket outlets are on individual fused circuits with unfused round pin plugs. Ring circuits consist of a fuse or miniature circuit breaker protected subcircuit with a 32 amp rating for a line conductor, neutral conductor and a cpc to earth looped from socket outlet to socket outlet. Metal conduit systems do not require a cpc wire providing the conduit is electrically sound and earthed. The number of socket outlets on a ring final circuit is unlimited but a separate circuit must be provided for every 100m<sup>2</sup> of floor area. To conserve wiring, spur outlets can be used as long as the total number of spur outlets does not exceed the total number of outlets connected to the ring and that there are not more than two outlets per spur.

Typical Ring Final Circuit Wiring Diagram ~

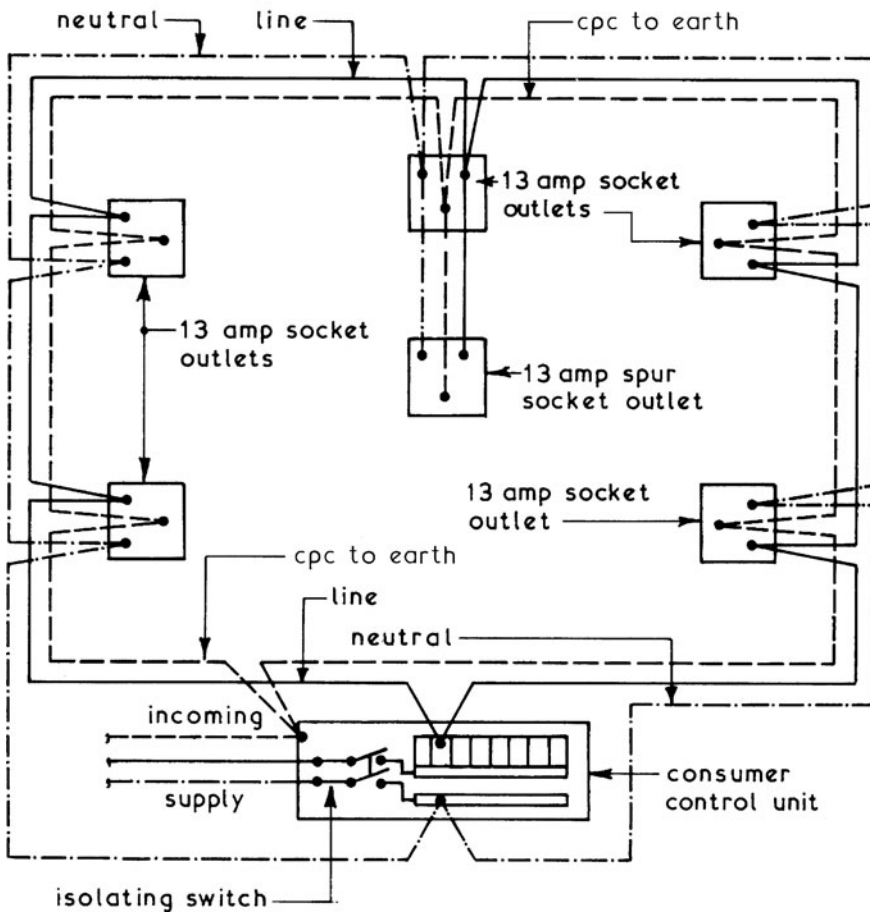

Lighting Circuits ~ these are usually wired by the loop-in method using a line, neutral and circuit protective conductor to earth cable with a 6amp fuse or miniature circuit breaker protection. In calculating the rating of a lighting circuit an allowance of 100watts per outlet should be used. More than one lighting circuit should be used for each installation so that in the event of a circuit failure some lighting will be in working order.

Typical Lighting Circuit Wiring Diagram ~

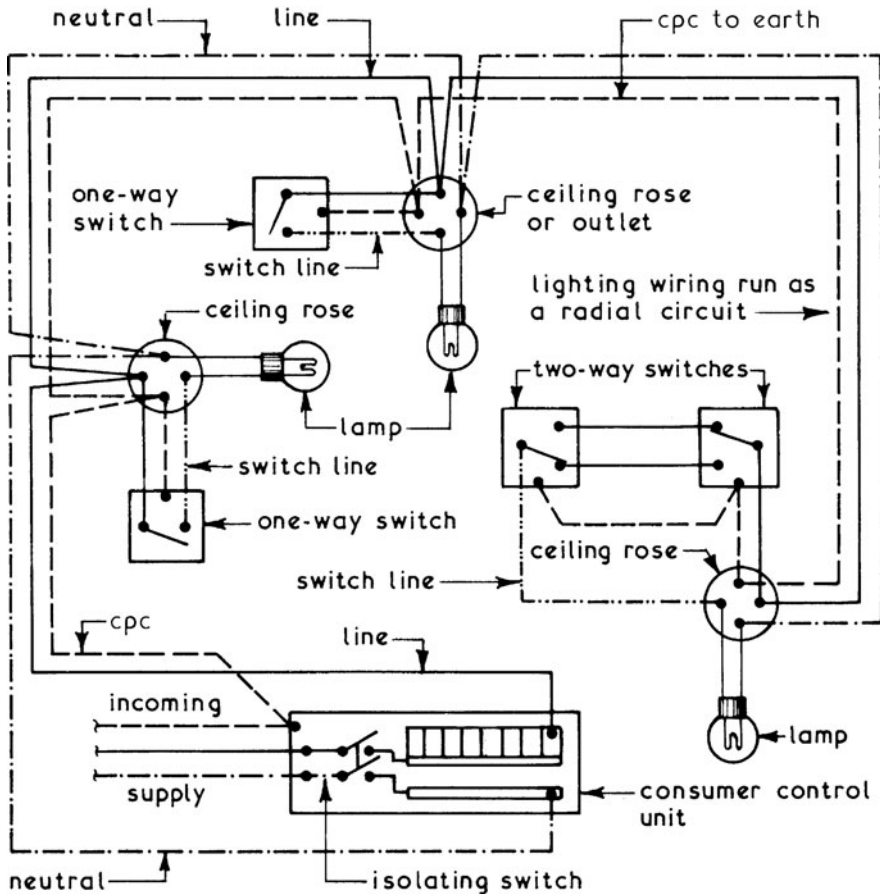

Electrical Accessories ~ for lighting circuits these consist mainly of switches and lamp holders, the latter can be wall mounted, ceiling mounted or pendant in format with one or more bulb or tube holders. Switches are usually rated at 5 amps and are available in a variety of types such as double or 2 gang, dimmer and pull or pendant switches. The latter must always be used in bathrooms.

## Gas Supply – Basic Requirements

Gas Supply ~ potential consumers of mains gas may apply to their local utilities supplier for connection, e.g. British Gas and E.ON amongst several others. The cost is normally based on a fee per metre run. However, where the distance is considerable, the gas authority may absorb some of the cost if there is potential for more customers. The supply, appliances and installation must comply with the safety requirements made under the Gas Safety (Installation and Use) Regulations, 1998, and Part J of the Building Regulations.

### Typical Gas Supply Arrangement ~

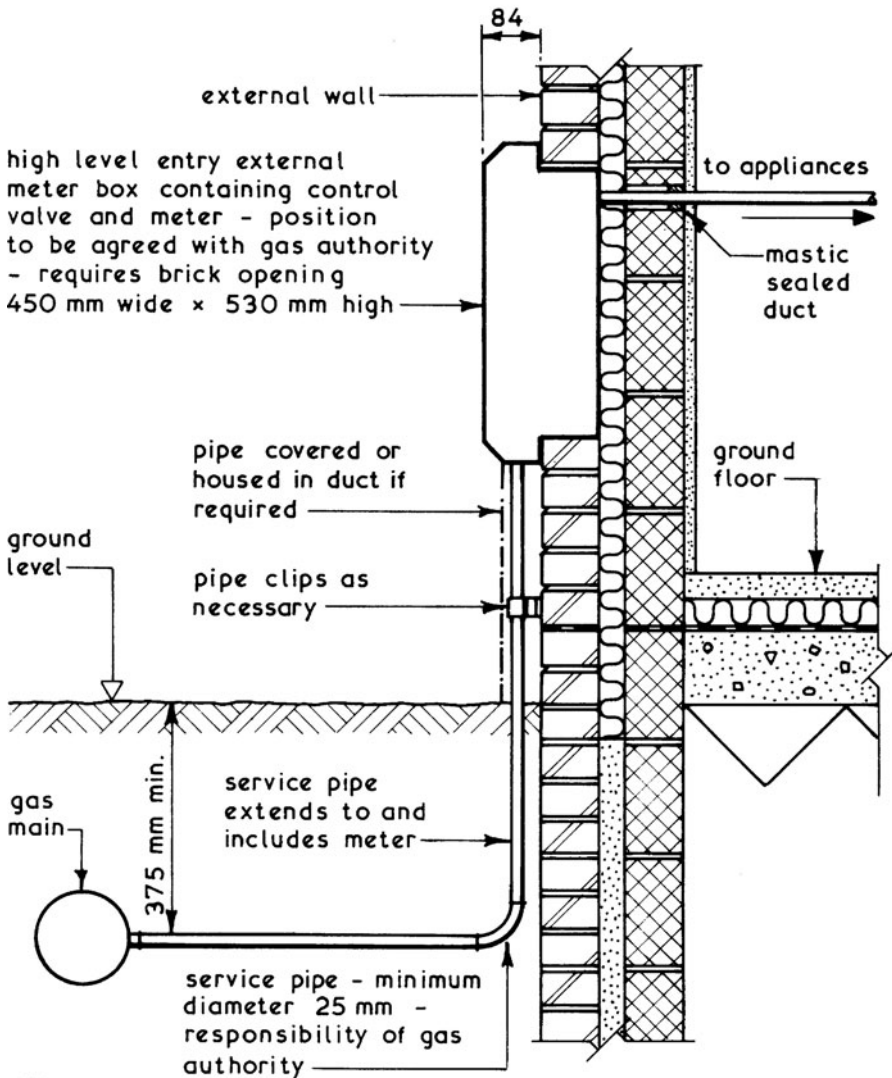

NB. For alternative gas supply arrangements see following page.

Gas Service Pipes:

1. Whenever possible the service pipe should enter the building on the side nearest to the main.
2. A service pipe must not pass under the foundations of a building.
3. No service pipe must be run within a cavity but it may pass through a cavity by the shortest route.
4. Service pipes passing through a wall or solid floor must be enclosed by a sleeve or duct which is end sealed with mastic.
5. No service pipe shall be housed in an unventilated void.
6. Suitable materials for service pipes are copper (BS EN 1057) and steel (BS EN 10255). Polyethylene (BS EN 1555) is normally used underground, but not above ground.

Typical Gas Supply Arrangement ~

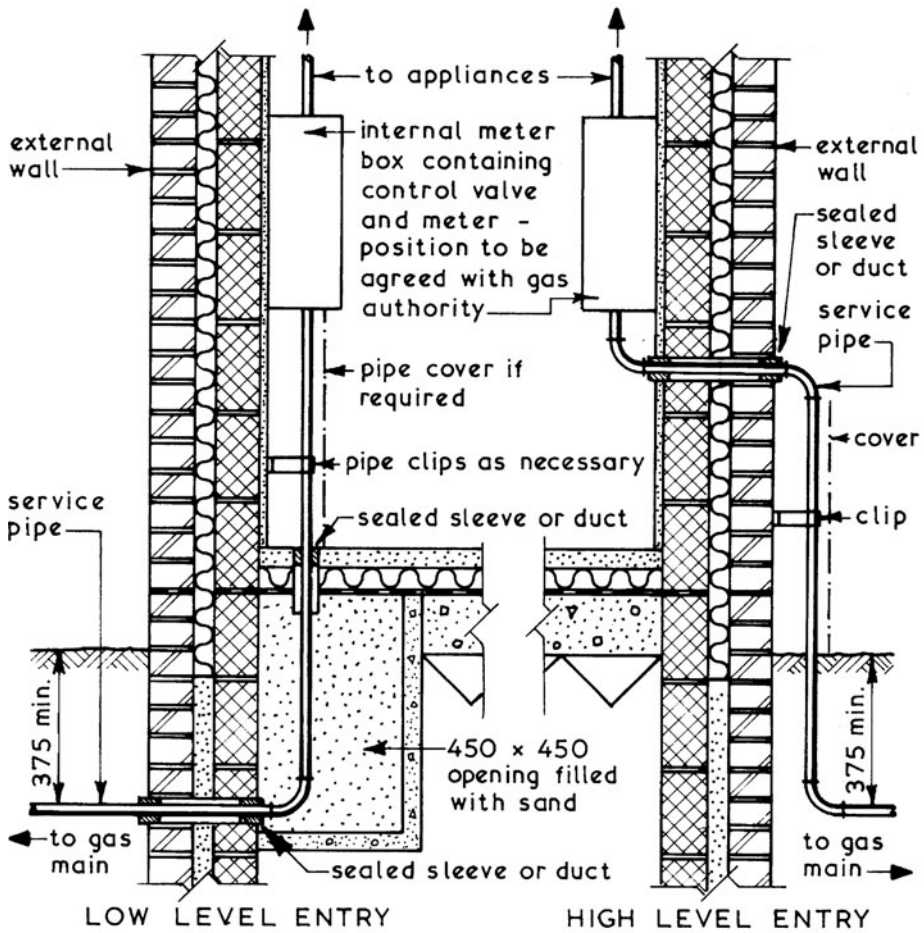

NB. For preferred method of entry see previous page.

# Gas Fires

Gas Fires ~ for domestic use these generally have a low energy rating of less than 7kW net input and must be installed in accordance with minimum requirements set out in Part J of the Building Regulations. Most gas fires connected to a flue are designed to provide radiant and convected heating whereas the room sealed balanced flue appliances are primarily convector heaters.

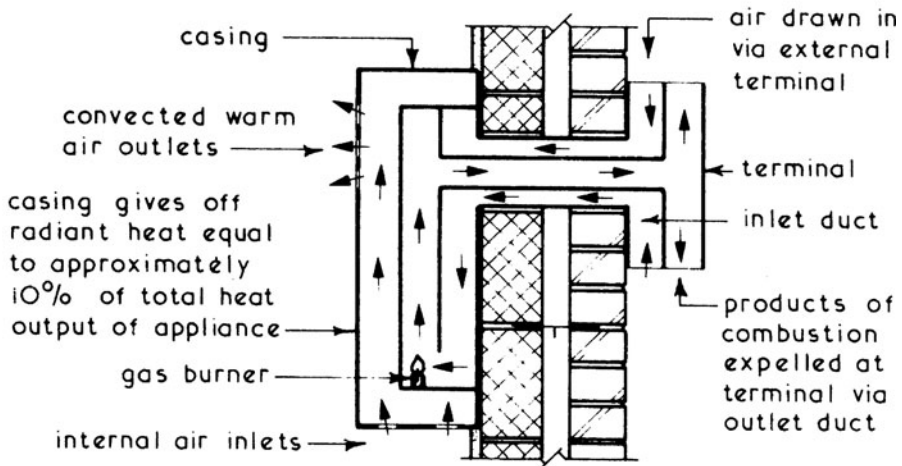
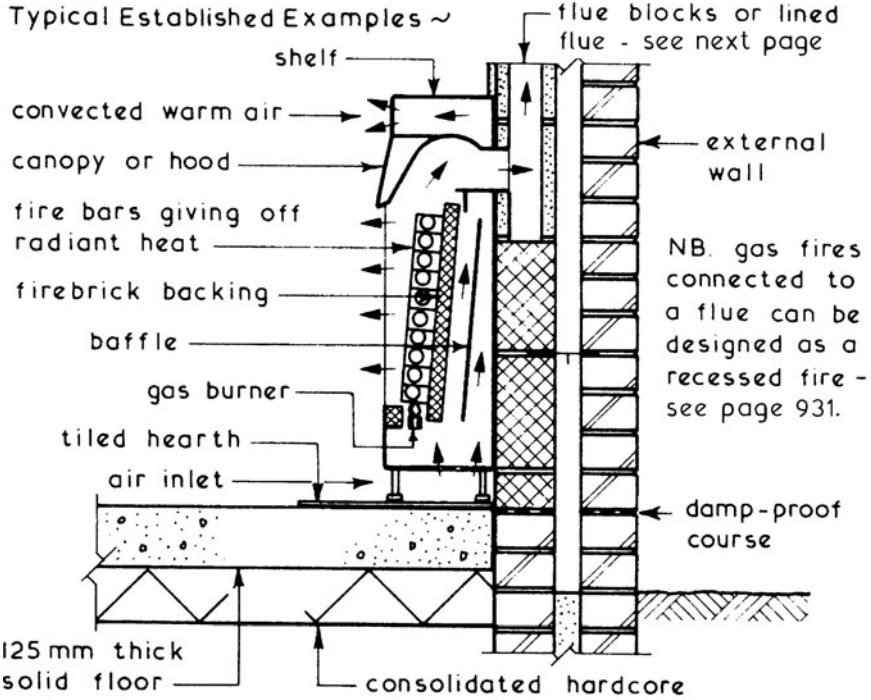

Gas Fire Flues ~ these can be defined as a passage for the discharge of the products of combustion to the outside air and can be formed by means of a chimney, special flue blocks or by using a flue pipe. In all cases the type and size of the flue as recommended in Approved Document J, BS EN 1806 and BS 5440 will meet the requirements of the Building Regulations.

#### Typical Single Gas Fire Flues ~

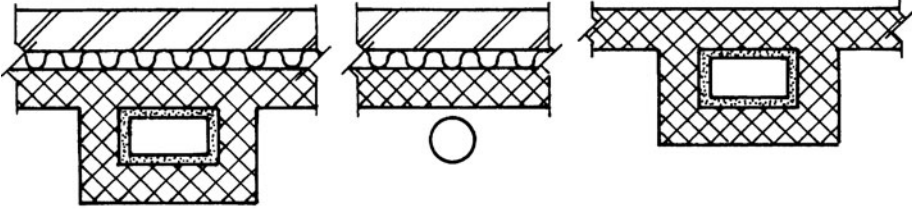

LINED CHIMNEY ON  
EXTERNAL WALL

FLUE PIPE ON  
EXTERNAL WALL

LINED CHIMNEY ON  
INTERNAL WALL

#### Flue Size Requirements:

1. No dimension should be less than 63 mm.
2. Flue for a decorative appliance should have a minimum dimension measured across the axis of 175 mm.
3. Flues for gas fires - min. area =  $12000\text{mm}^2$  if round,  $16500\text{mm}^2$  if rectangular and having a minimum dimension of 90 mm.
4. Any other appliance should have a flue with a cross sectional area at least equal to the outlet size of the appliance.

#### Flue Blocks ~

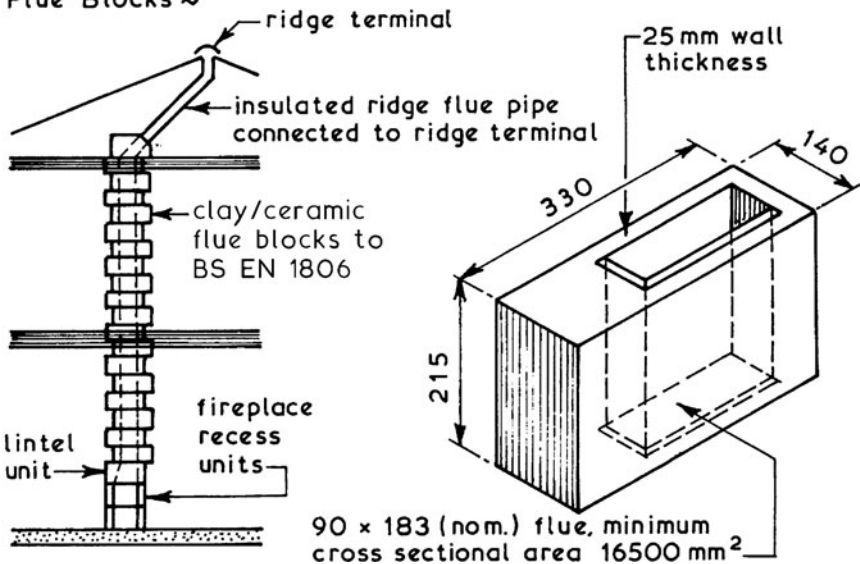



Open Fireplace Recesses ~ these must have a constructional hearth and can be constructed of bricks or blocks of concrete or burnt clay or they can be of cast in-situ concrete. All fireplace recesses must have jambs on both sides of the opening and a backing wall of a minimum thickness in accordance with its position and such jambs and backing walls must extend to the full height of the fireplace recess.

## Typical Examples ~

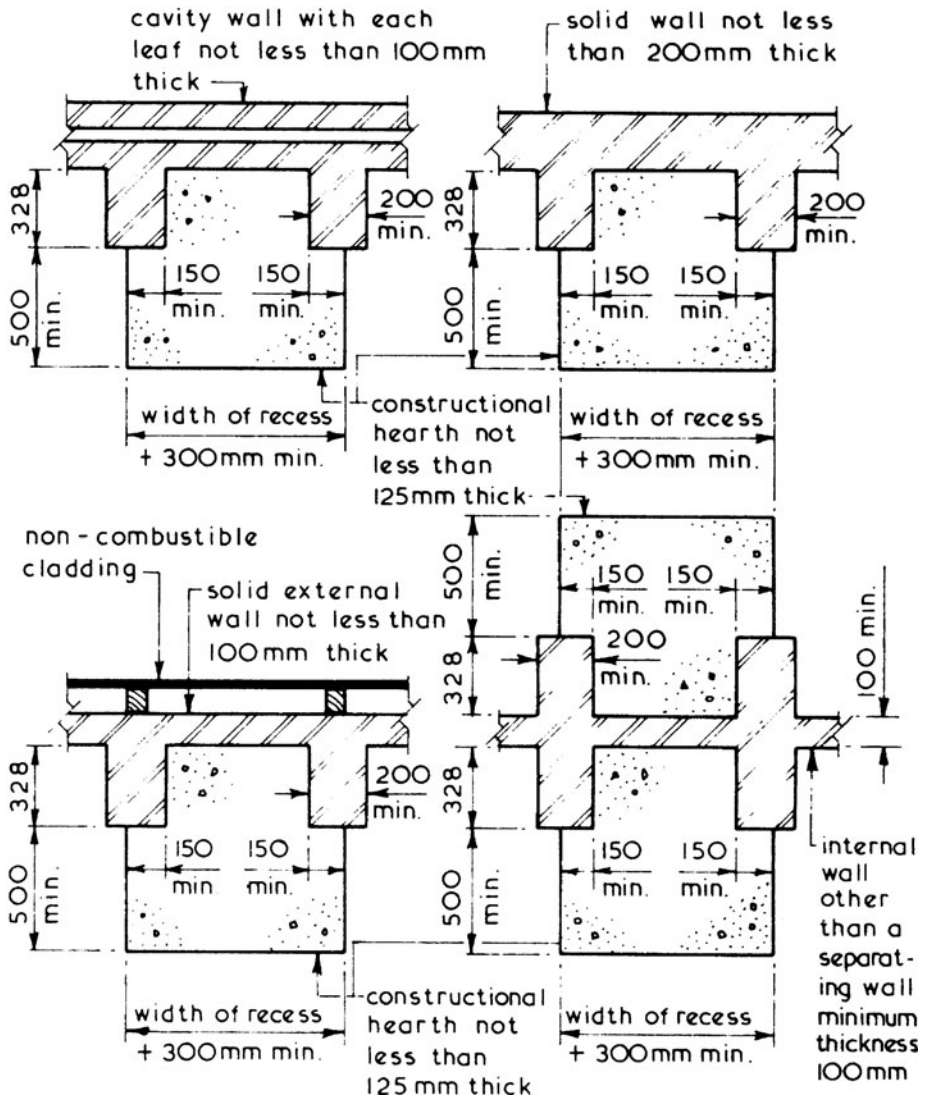



# Open Fireplaces and Flues

## Traditional Fireplace Details ~

\*200 mm min. if fireplace opening >500 mm x 550 mm

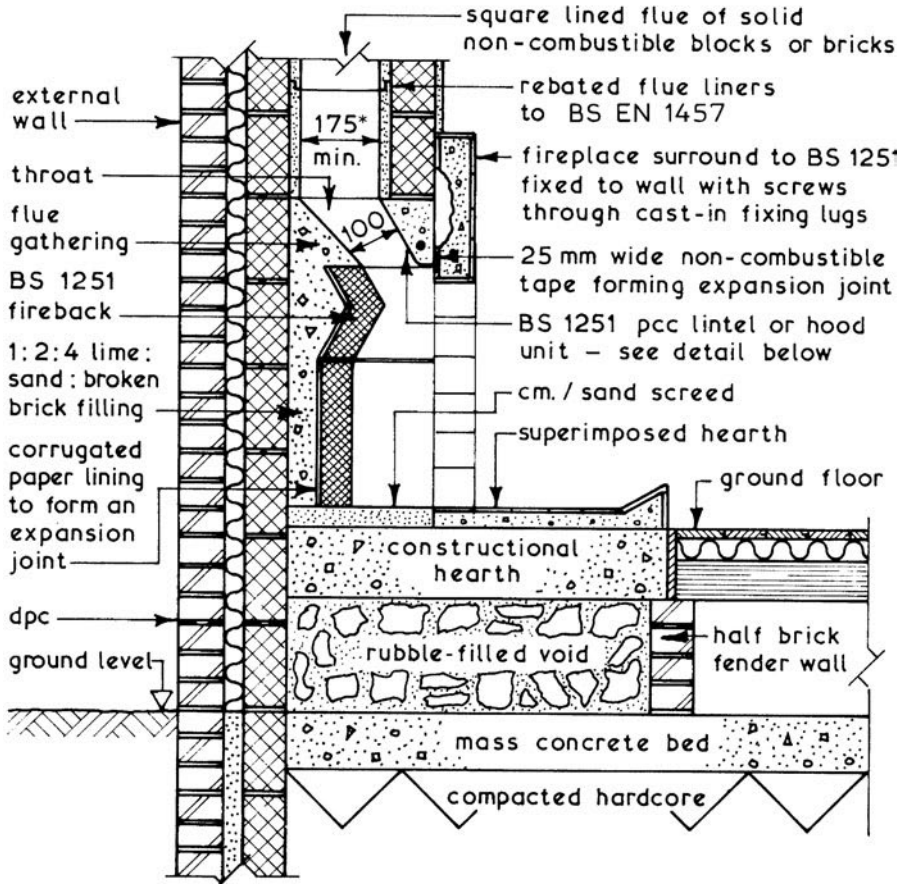

NB. in solid floor construction the constructional hearth is an integral part of the oversite concrete bed.

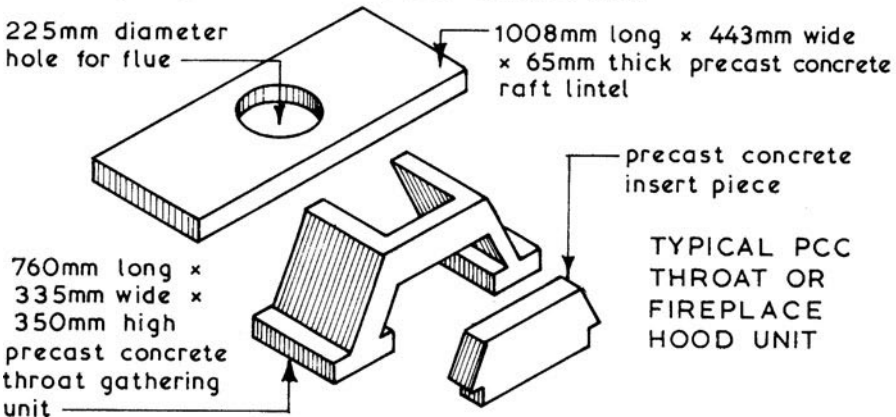

Open Fireplace Chimneys and Flues ~ the main functions of a chimney and flue are to:

1. Induce an adequate supply of air for the combustion of the fuel being used.
2. Remove the products of combustion.

In fulfilling the above functions a chimney will also encourage a flow of ventilating air promoting constant air changes within the room which will assist in the prevention of condensation.

Approved Document J recommends that all flues should be lined with approved materials so that the minimum size of the flue so formed will be 200mm diameter or a square section of equivalent area. Flues should also be terminated above the roof level as shown, with a significant increase where combustible roof coverings such as thatch or wood shingles are used.

Typical Examples ~

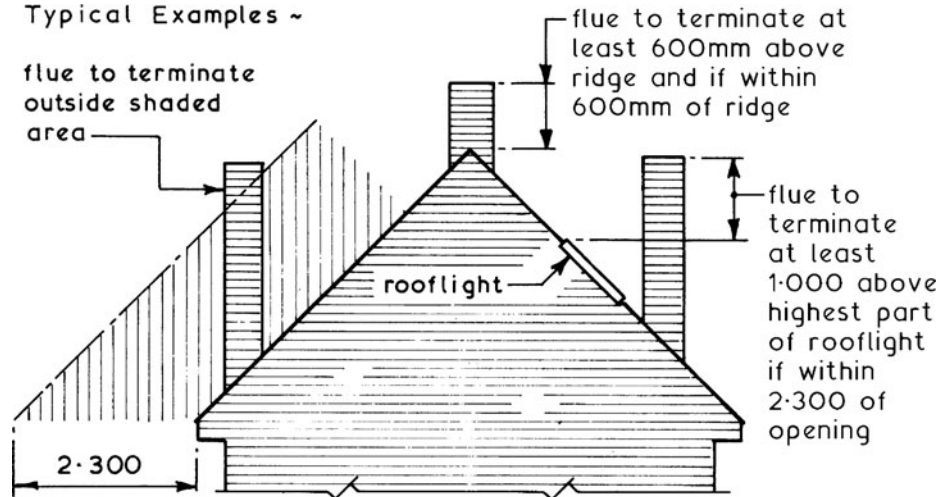

ROOF WITH A PITCH OF OVER 10°

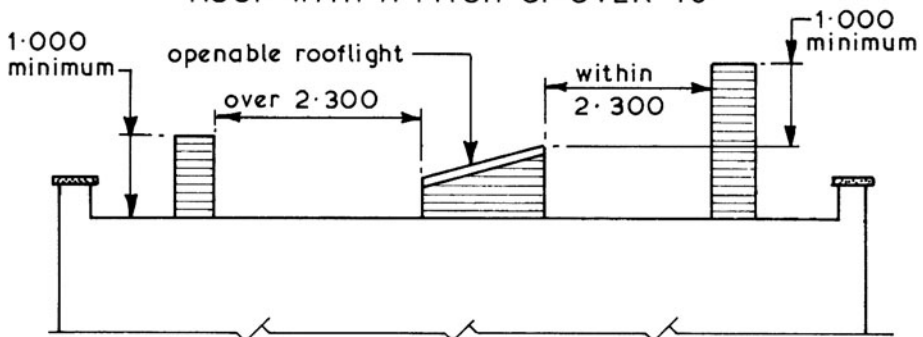

ROOF WITH PITCH OF LESS THAN 10°

# Open Fireplaces and Flues

## Typical Flue Liner and Chimney Pot Details ~

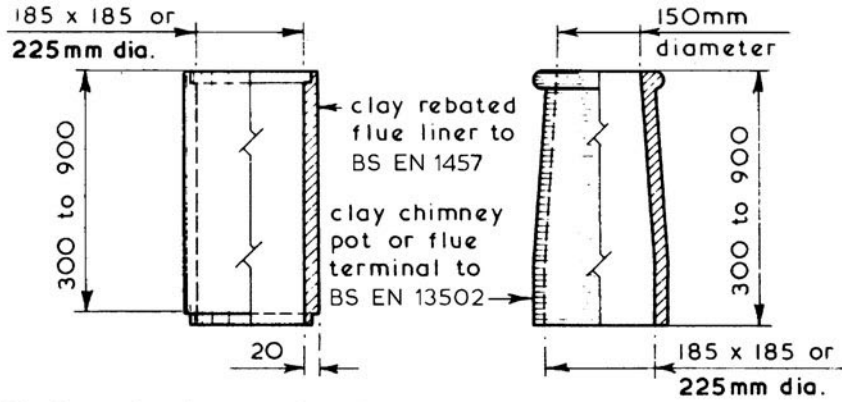

## Typical Outlet or Terminal Details ~

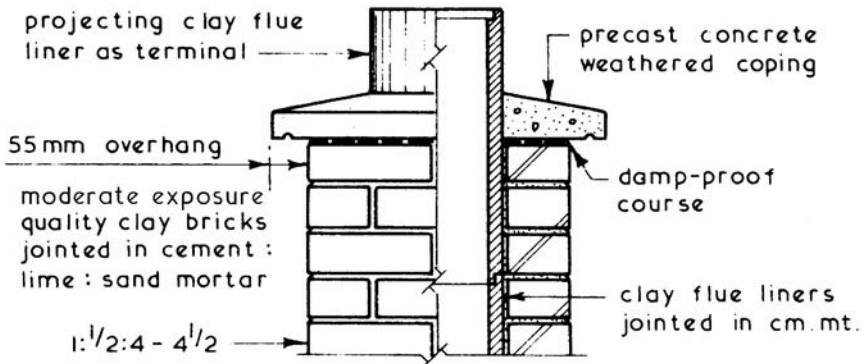
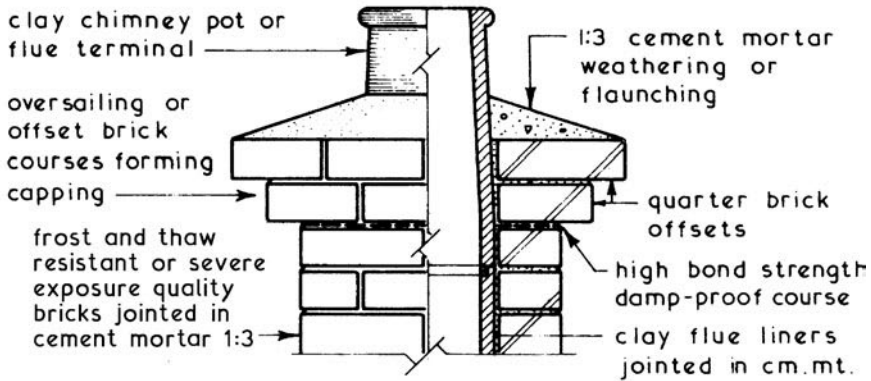

Refs.: BS EN 13502: Chimneys. Requirements and test methods for clay/ceramic flue terminals.

BS EN 1457: Chimneys. Clay/ceramic flue liners. Requirements and test methods.

BS EN 771-1: Specification for (clay) masonry units.

Typical Chimney and Roof Junction Details ~

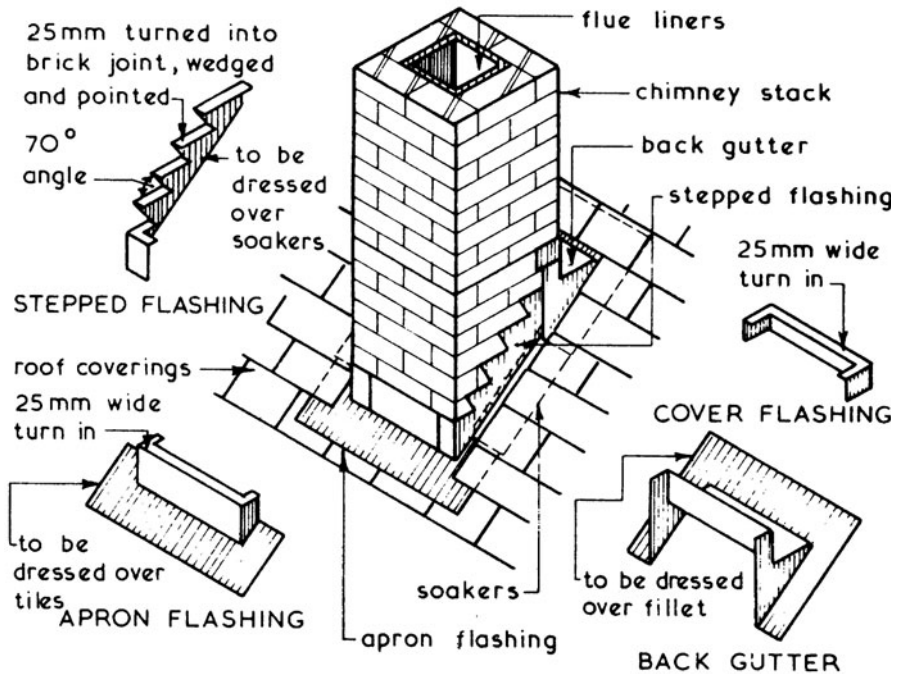

NB. All flashings, aprons and gutter linings to be formed out of 1.75mm lead or other durable material(s). Soakers out of 1.25mm lead.

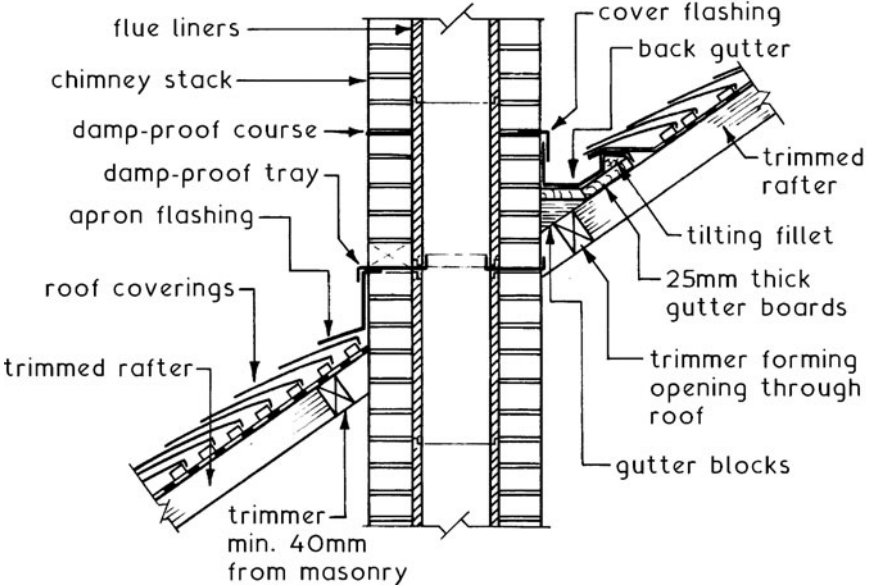

Ref. BS EN 1443: Chimneys. General Requirements.

# Open Fireplaces and Flues

## Chimney Construction -

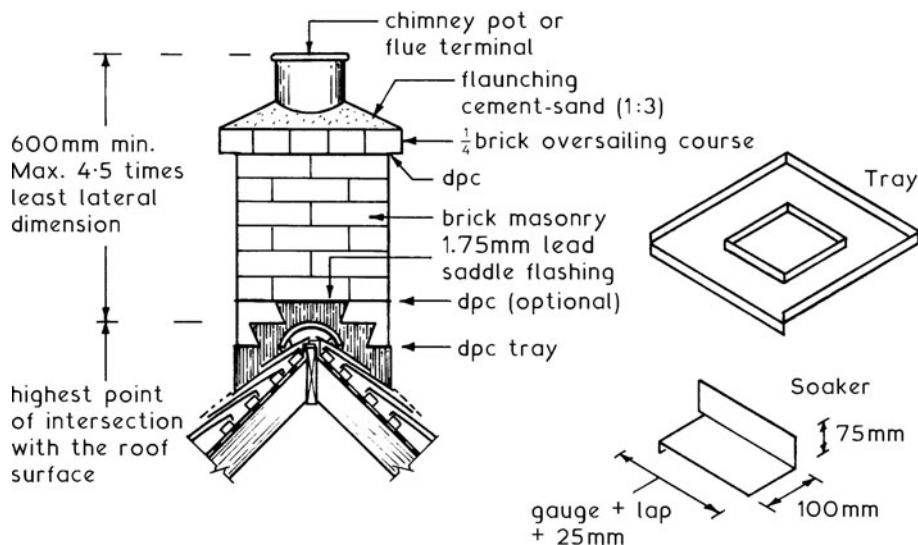

## Typical Chimney Outlet -

Clay bricks - Frost and thaw, severe exposure-resistant quality. Min. density  $1500\text{kg/m}^3$ .

Calcium silicate bricks - Min. compressive strength  $20.5\text{N/mm}^2$  ( $27.5\text{N/mm}^2$  for cappings).

Precast concrete masonry units - Min. compressive strength  $15\text{N/mm}^2$ .

Mortar - A relatively strong mix of cement and sand 1:3. Cement to be specified as sulphate resisting because of the presence of soluble sulphates in the flue gas condensation.

Chimney pot - The pot should be firmly bedded in at least three courses of brickwork to prevent it from being dislodged in high winds.

Flashings and dpcs - Essential to prevent water which has permeated the chimney from penetrating the building. The minimum specification is 1.75mm lead, 1.25mm for soakers. This should be coated both sides with a solvent-based bituminous paint to prevent the risk of corrosion when in contact with cement. The lower dpc may be in the form of a tray with edges turned up 25mm, except where it coincides with bedded flashings such as the front apron upper level. Here weep holes in the perpends will encourage water to drain. The inside of the tray is taken through a flue lining joint and turned up 25mm.

Combustion Air ~ it is a Building Regulation requirement that in the case of open fireplaces provision must be made for the introduction of combustion air in sufficient quantity to ensure the efficient operation of the open fire. Traditionally such air is taken from the volume of the room in which the open fire is situated. This can create air movements resulting in draughts. An alternative method is to construct an ash pit below the hearth-level fret and introduce the air necessary for combustion via the ash by means of a duct.

## Typical Established Details ~

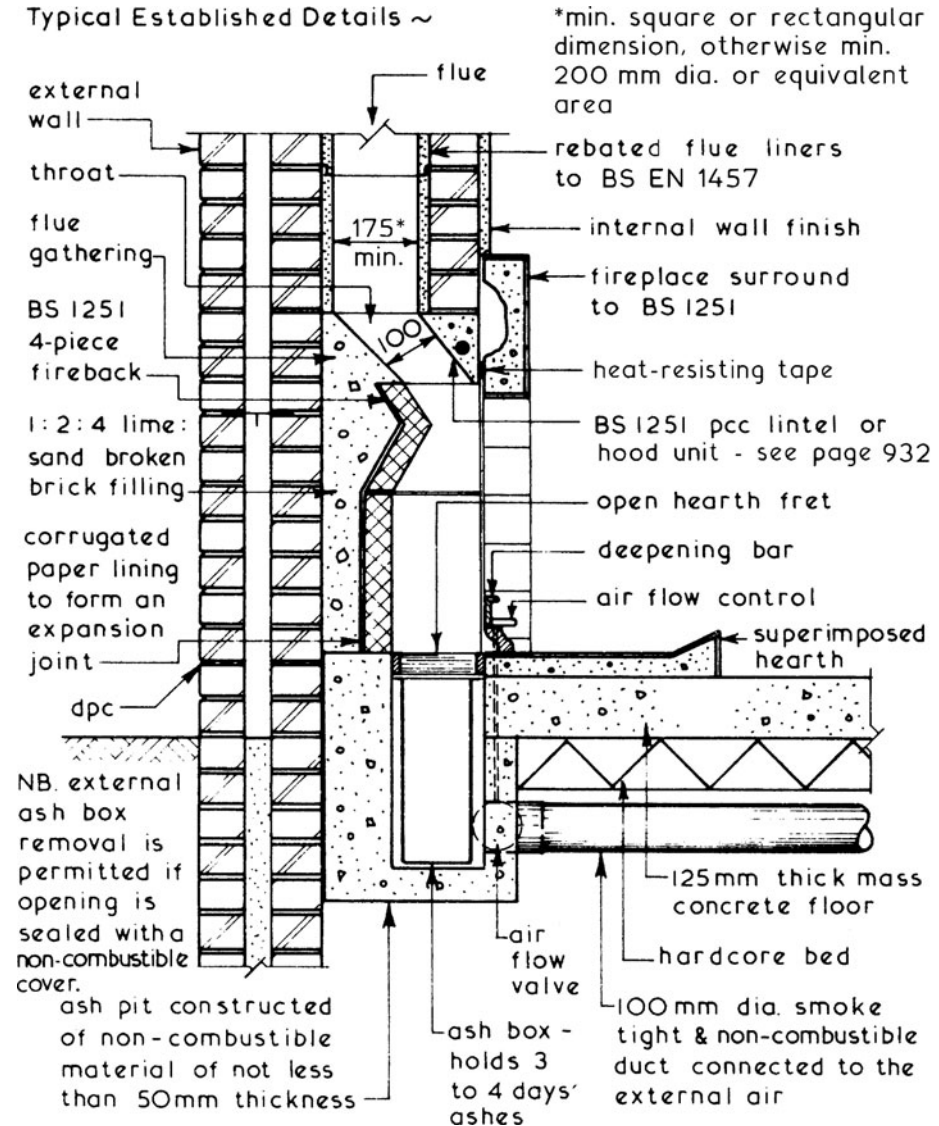

Ref. BS 1251: Specification for open-fireplace components.

## Open Fireplaces and Flues

Lightweight Pumice Chimney Blocks ~ these are suitable as a flue system for solid fuels, gas and oil. The highly insulative properties provide low condensation risk, easy installation as a supplement to existing or ongoing construction and suitability for use with timber frame and thatched dwellings, where fire safety is of paramount importance. Also, the natural resistance of pumice to acid and sulphurous smoke corrosion requires no further treatment or special lining. A range of manufacturer's accessories allow for internal use with lintel support over an open fire or stove, or as an external structure supported on its own foundation. Whether internal or external, the units are not bonded in, but supported on purpose-made ties at a maximum of 2-metre intervals.

flue (mm)	plan size (mm)
150 dia.	390 × 390
200 dia.	440 × 440
230 dia.	470 × 470
260 square	500 × 500
260 × 150 oblong	500 × 390

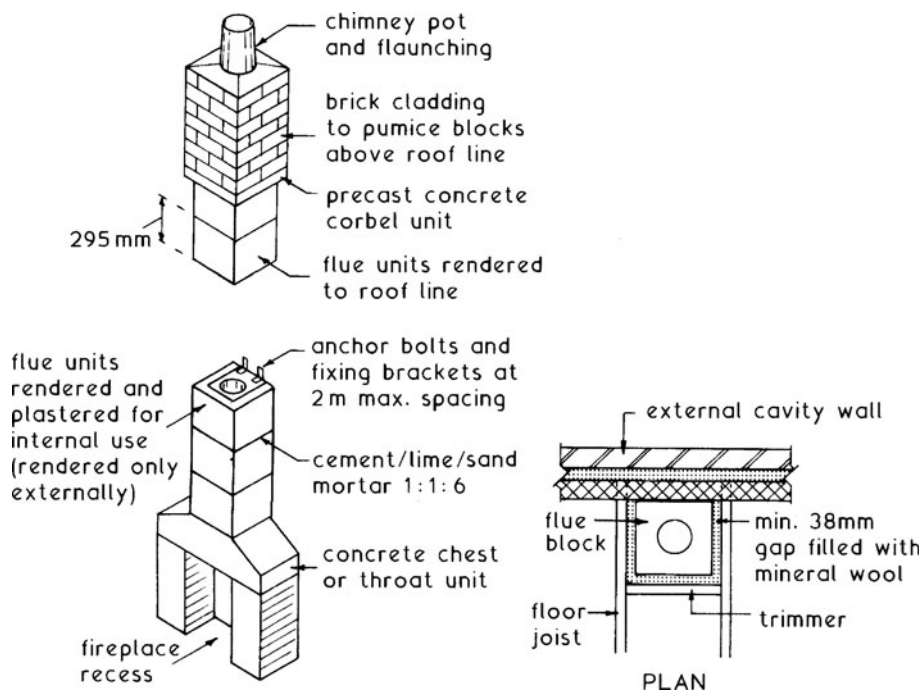

Fire Protection of Services Openings ~ penetration of compartment walls and floors (zones of restricted fire spread, e.g. flats in one building) by service pipes and conduits is very difficult to avoid. An exception is where purpose-built service ducts can be accommodated. The Building Regulations, Approved Document B3: Sections 7 [Vol. 1] and 10 [Vol. 2] determines that where a pipe passes through a compartment interface, it must be provided with a proprietary seal. Seals are collars of intumescent material which expands rapidly when subjected to heat, to form a carbonaceous charring. The expansion is sufficient to compress warm plastic and successfully close a pipe void for up to four hours.

In some circumstances fire stopping around the pipe will be acceptable, provided the gap around the pipe and hole through the structure are filled with non-combustible material. Various materials are acceptable, including reinforced mineral fibre, cement and plasters, asbestos rope and intumescent mastics.

Pipes of low heat resistance, such as PVC, lead, aluminium alloys and fibre cement, may have a protective sleeve of non-combustible material extending at least 1m either side of the structure.

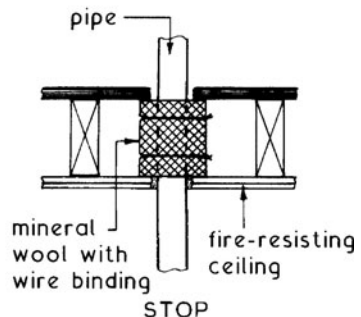
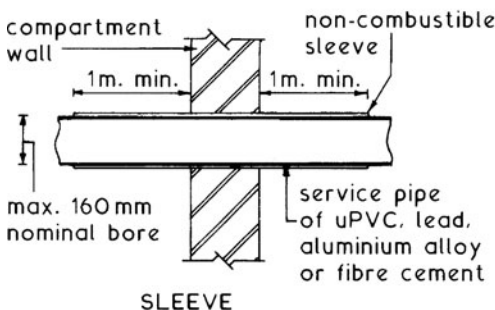
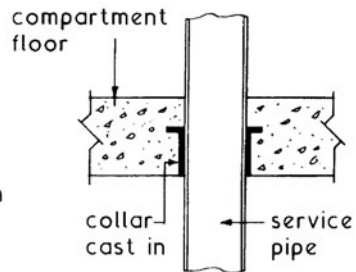
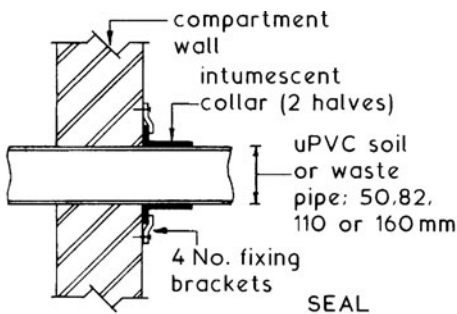



# Telephone Installations – Basic Requirements

Telephone Installations ~ unlike other services such as water, gas and electricity, telephones cannot be connected to a common mains supply. Each telephone requires a pair of wires connecting it to the telephone exchange. The external supply service and connection to the lead-in socket is carried out by telecommunication engineers. Internal extensions can be installed by the site electrician.

## Typical Supply Arrangements ~

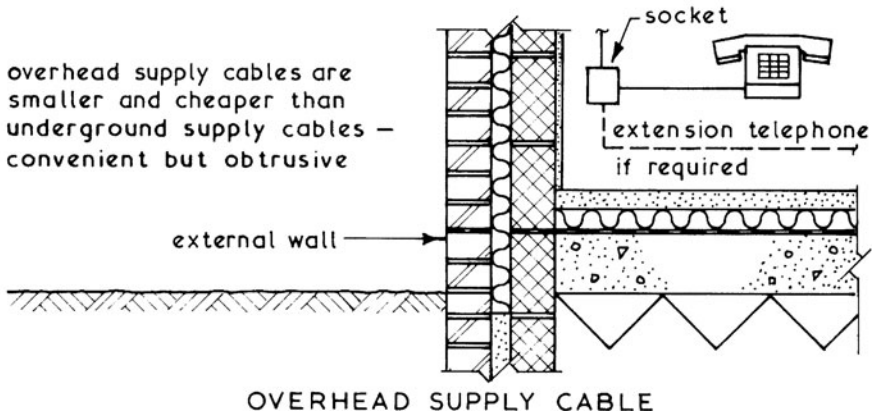
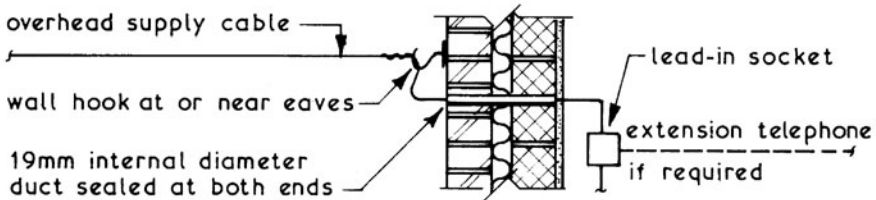
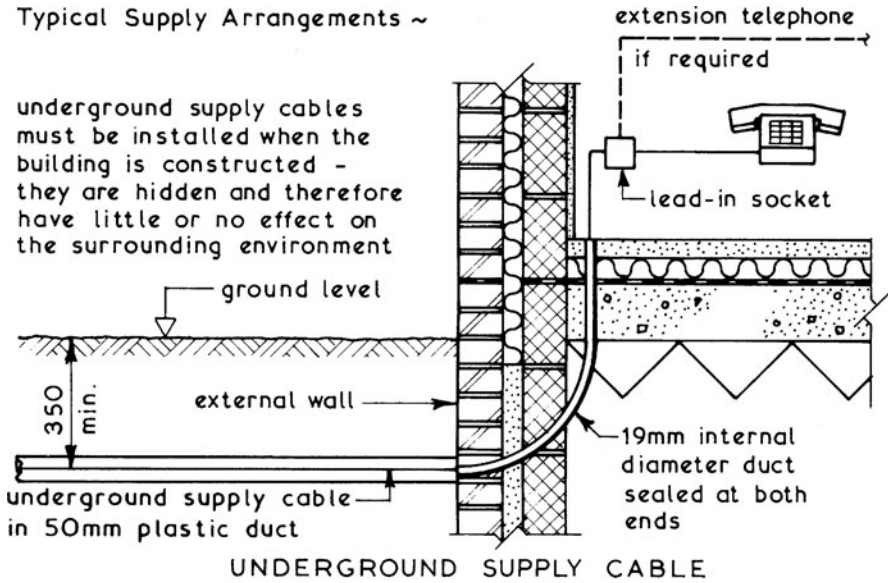

Electronic Installations - in addition to standard electrical and telecommunication supplies into buildings, there is a growing demand for cable TV, security cabling and broadband access to the Internet. Previous construction practice has not foreseen the need to accommodate these services from distribution networks into buildings, and retrospective installation through underground ducting is both costly and disruptive to the structure and surrounding area, particularly when repeated for each different service. Ideally there should be a common facility integral with new construction to permit simple installation of these communication services at any time. A typical installation will provide connection from a common external terminal chamber via underground ducting to a terminal distribution box within the building. Internal distribution is through service voids within the structure or attached trunking.

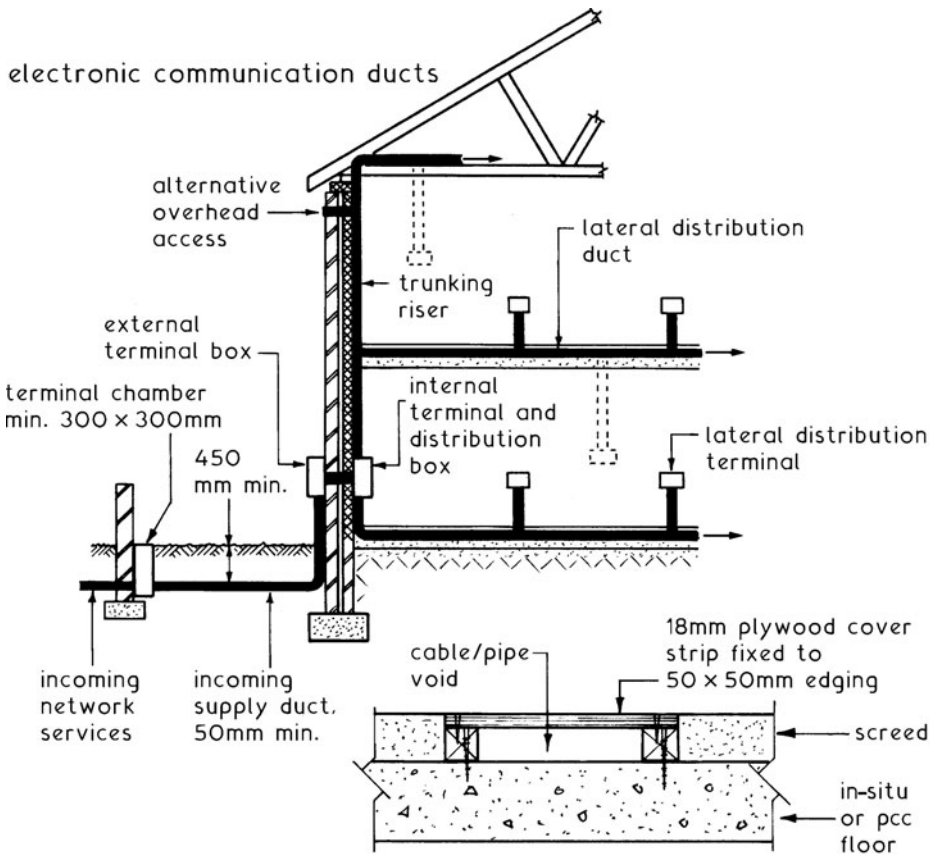

Typical lateral distribution duct  
(see also Part 15 - *Building Services Handbook*).

*This page intentionally left blank*

# INDEX

- AAV (air admittance valve) 910  
abutment details: double lap tiling 513;  
    single ply roof membranes 536;  
    timber flat roofs 524, 530  
access for the disabled 586–9  
access to site 112  
accredited construction details 71  
acrylic sealants 864  
adhesion of concrete 240  
adhesives: brick slip cladding 489;  
    laminated timber 654, 860; parallel  
    strand beams (PSB) 656; polyvinyl  
    acetate (PVA) 481  
admixtures, concrete 313  
aggregates 250, 325; artificial stones 373;  
    site storage 326; testing grading 134;  
    *see also* sand  
Agrément certification 77  
air admittance valve (AAV) 910  
air bricks 760  
air infiltration *see* airtightness  
air permeability *see* airtightness  
air space resistances 550  
airtightness 559; draughtproofing 583;  
    performance standards 71; testing 585  
alterations *see* building alterations  
alternating tread stairs 810  
aluminium alloy support frames 707  
aluminium alloy windows 437; curtain  
    walling 711; hollow core 454  
aluminium covered roofs 665, 872  
aluminium stearate 411  
aluminium surface coating 454  
anchorage: ground anchors 309, 627; post-  
    tensioned reinforced concrete 625  
angle piling 347  
angles of repose, excavations 322  
annexes 391  
apartment buildings *see* flats  
Approved Documents 62–3  
approved inspectors 65, 67  
apron cladding panels 715  
apron flashing 935  
arches 425–7; cavity trays 426–7;  
    construction 425; loads 6; stonework  
    377; terminology 424  
architects' drawings 20  
architectural form 4  
architraves 857  
area weighted average U-value 564  
argon double glazing fill 455  
artificial stones 373, 375  
asbestos removal 197  
ashlar 373–5, 377  
asphalt: density 39; thermal performance  
    551; *see also* mastic asphalt  
assembly drawings 21  
assembly stairs 827  
asset rating 33  
asymmetric beams 793  
attached piers 389–90, 420–1  
Atterberg limits test 110  
auger bored piles 272–3, 355  
auger holes 92, 97  
axial grid 53  
axonometric projections 24  
  
backacters 204, 211, 321  
back gutters, chimney stacks 935  
balloon frame 475  
balusters 806, 807, 826  
balustrades 826  
band saws 854  
bar chart programmes 37  
barrel bolt 466  
barrel vaults 685–7, 693  
baseboard 753, 844  
baseline, setting out 154  
basements: excavations 304–7; insulation  
    318; slabs 314; substructure 11; walls  
    314, 356–7; waterproofing 313–17,  
    355–9  
base plates 618, 635  
basic module grid 52  
baths 906  
bats (bricks) 382, 384, 395  
battenboard 860  
batten gauge 517  
battens, plasterboard fixing 754  
bays, underpinning 342, 343  
bay windows 445  
BBA (British Board of Agrément) 77

- beams: loads 16; *see also* joists; reinforced concrete beams; structural steel beams; timber beams
- bedding: drains 889; wall tiles 757
- bed joints 394
- beech 859
- Belfast truss 676, 677
- below-ground structure *see* substructure
- benchmark checklist 66
- benchmarks, setting out 154, 158, 160
- bentonite 269, 356
- BERR (Department for Business Enterprise and Regulatory Reform) 76
- bevelled closers 395
- bib tap 901
- bills of quantity 20
- BIM (building information modelling) 81–4
- binders, paint 850
- bioremediation 367
- birdcage scaffolds 180
- bitumen: damp-proof courses 409; mastic 863
- bitumen polymer damp-proof courses 409
- bituminous felt: roof underlay 504; thermal performance 551; timber flat roof covering 529
- black bolts 637
- bleeding, paintwork 853
- blinds, in triple glazing 457
- blistering, paintwork 853
- block and site plans 27
- blockboard 860
- blocks 399; artificial stones 373; fire resistance 736; storage on site 130; typical weights 38
- blockwork: internal walls 732; sound insulation 797, 798; thermal performance 551
- blooming, paintwork 853
- blow holes, concrete 725
- board cladding 482
- boarded web girders 655
- board materials 860–1; painting 852; typical weights 38; *see also* particle boards; plywood
- boilers, energy efficiency 562
- bolt boxes 618, 635
- bolted connections, structural steelwork 637
- bolts, types 637
- bonding: blockwork 399; brickwork 383–9
- bonding ties 734
- bonnet hip tiles 505, 512
- boot lintel 428
- bored piles 259, 267–9, 355
- boreholes: jet grouting 364; soil investigation 99; sump pumping 351–2; vapour extraction 366
- boring methods 97–8
- bottom hung casement 433
- bottom rail 439
- bowstring truss 675, 677
- box and cellular raft basements 308
- box beams, timber 655
- box caisson 337
- box construction 8
- box culvert 339, 340
- box piles 278
- BPIC (Building Project Information Committee) 82
- branch discharge pipes 908, 909
- breather membranes 504, 510
- BRE (Building Research Establishment) 76
- Bressummer beam 779
- brick infill panels 702
- brick panel walls 699
- bricks: compressive strength 381; fire resistance 736; manufacture 379–81; site tests 132; specials 395–7; storage on site 128, 130; typical weights 38; *see also* calcium silicate bricks
- brick slip cladding 489
- brickwork 382–94; attached piers 389–91; bonding 383–8; calculated 417–21; compressive strength 418; internal walls 731; jointing and pointing 393; movement joints 392, 700; slenderness ratio 419; sound insulation 797, 798; thermal performance 549, 551
- bright bolts 637
- British Board of Agrément (BBA) 77
- British Standards (BS) 73
- British Woodworking Federation (BWF) 436
- British Woodworking Manufacturers Association (BWMA) 436
- broken bond 383
- brown-field development 365
- buckling: reinforced concrete columns 603; structural steel columns 645
- Building Act 1984 60; demolition 195, 196
- building alterations: building control 65; Energy Performance Certificates (EPC) 32; thermal performance 562, 563
- building control 64–9; demolition 195; *see also* planning applications
- building envelope *see* external envelope
- building environment 2–4
- building extensions: building control 65, 69; Energy Performance Certificates (EPC) 32; permitted development 46, 47; thermal performance 562, 563
- building form *see* architectural form
- building information management (BIM) 81
- building information modelling (BIM) 81–4

- building materials: damp-proof courses 409; densities 39, 551–2; foundations 250; storage on site 126–31; thermal performance 551–2; typical weights 38–9
- building notice 64, 68
- building orientation *see* orientation of building
- Building Project Information Committee (BPIC) 82
- Building Regulations: Approved Documents 62–3; building control 64–9; exemptions 69; history and development 58–60
- Building Research Establishment (BRE) 76
- building services: communications 940–1; drainage 868–91; electrical installations 917–25; gas installations 926–9; hot and cold water 892–916; National Engineering Specification (NES) 83; open fireplaces and flues 930–8; service openings 939
- building sites *see* construction sites
- buildings of special historic or architectural interest 152
- building survey 29–31
- built-in beam 5
- bulk density, soils 107
- bulkhead lamp 120
- bulking testing 133
- bulldozers 205
- butt hinges 466
- buttress walls 405
- butt welds 636
- BWF (British Woodworking Federation) 436
- BWMA (British Woodworking Manufacturers Association) 436
- cable construction 10
- cables, electrical *see* electrical cables
- cables, prestressed concrete 622
- caissons 337–8
- calcium silicate board, thermal performance 551
- calcium silicate bricks: compressive strength 418; fire resistance 736; manufacture 381; movement joints 392; uniformity 394; weight 38
- camber arch 425
- cantilever beams 5, 693
- cantilevered structures 661
- cantilever foundations 265
- cantilever retaining walls 293
- cantilever scaffolds 182
- cantilever stairs 815
- cantilever steel beams 643
- capping, contaminated soil 366
- carbon emissions *see* CO<sub>2</sub> emissions
- carbon factor (CF) 567
- carbon index (CI) 567
- car parking for the disabled 587
- carpets and carpet tiles 764
- carports 69
- Casagrande cup test 111
- casein 654
- casement fastener 438
- casement stay 438
- casement windows 433, 454
- castellated steel beams 631
- cast in-situ concrete *see* in-situ concrete
- cast-on finishes, concrete 722
- cast stone 373, 375; subsill 430
- catch pits 876
- cavity barriers: concealed spaces 849; party walls 737; separating walls 737; steel frame construction 478; timber frame construction 476
- cavity closers 408, 414, 429, 508, 582, 583
- cavity insulation 572–3; potential CO<sub>2</sub> reduction 568; retrofitting 575–6; thermal bridging 580–2
- cavity trays: arches 426–7; gas-resistant construction 416; precast concrete ground floors 761; reinforced concrete raft foundations 260; timber flat roofs 525
- cavity walls 400–3; calculations 417, 419; damp-proof courses 403, 413; drained cavity system 317; minimum requirements 401–3; opening details 428–31; sound insulation 797; stonework 378; thermal bridging 580; thermal insulation 568, 572–3, 575–6, 578, 581–2; thermal performance 555–6, 561; U-values 572–3, 575–6, 578
- CDM Coordinator 55
- ceiling board 753
- ceilings: loads 15; plasterboard 783, 844; thermal performance 550, 849; *see also* suspended ceilings
- cellular basement 308
- cellular core door 835
- CE mark 75
- cement 250, 325; site storage 326
- cement bonded particle board 527
- cement grouts 358, 364
- cement mortars 422–3; thermal performance 551
- cement screed *see* concrete floor screeds
- central heating boilers, energy efficiency 562

- central heating systems 897  
 centre arch 425  
 centre nailed slates 157  
 ceramic tiles 756  
 ceramic wash basins 905  
 certificates of ownership 45, 51  
 certification: benchmark checklist 66; BRE Certification Ltd 76; Building Regulations compliance 67; CE mark 74; fire doors 838; hot water and heating systems 565; structural timber 140  
 CF (carbon factor) 567  
 chain link fencing 126  
 chalking, paintwork 853  
 checked masonry 431  
 chemical damp-proof courses 411–12  
 chemical grouts 358  
 chemical treatments, contaminated soil 367  
 Chezy formula 891  
 chimney flues *see* flues  
 chimney pots 934–5, 936  
 chimney stacks 935–6  
 chipboard 861; flat roof decks 527; floor finishes 765  
 CI (carbon index) 567  
 circular saws 854  
 CIRIA (Construction Industry Research and Information Association) 77  
 CIRS (Construction Industry Scaffolders Registration Scheme) 185  
 CIS (Construction Information Service) 83  
 CI/SfB system 78, 81, 82  
 cisterns: hot and cold water storage 902–3; water closets 907  
 cladding 482–9; brickwork 700; curtain walling 710–13; over-cladding in glass 713; precast concrete panels 701, 714–20; rainscreen cladding (RSC) 577–8, 705–7; stone 375; structural glazing 708–9; *see also* tile hanging  
 clamp boring 379  
 clamp vibrators 238  
 classification systems 78–80, 82–3  
 clay bricks: compressive strength 418; fire resistance 736; manufacture 379–80; movement joints 392, 734; uniformity 394; weights 38  
 clay soils 245, 246; angles of repose 322; foundations 255, 259; investigation 100–1; shrinkage 109; thermal conductivity 552  
 climbing cranes 228, 232  
 climbing formwork 295  
 closed couple roof 496  
 closers (bricks) 395  
 CO<sub>2</sub> conversion factors 567  
 CO<sub>2</sub> emission rate 33; targets 72, 567–8  
 coarse aggregate 325  
 COBie (Construction Operations Building information exchange) 82  
 Code for Sustainable Homes 72  
 Codes of Practice (CP) 73  
 coding systems 78–80, 82–3  
 cofferdams 333–4  
 coffered floor 785–6  
 coil ties 616  
 cold bridging *see* thermal bridging  
 cold decks 523, 525, 528, 530  
 cold rolled steel 628  
 cold roofs 507–8, 569  
 cold water installations 894–5; flow controls 901  
 cold water storage cisterns 902  
 collar roof 496, 497  
 colour codes, health and safety 56  
 Columbian pine 858  
 columns: fire protection 609; loads 16, 421; underpinning 348; *see also* reinforced concrete columns; structural steel columns  
 column stanchion *see* vertical strut  
 combined column foundations 263  
 combined method (U-values) 556  
 combustion air 937  
 commissioning, hot water and heating systems 565  
 Common Arrangement of Work Section (CAWS) 79, 82  
 compaction, soil 361–4  
 compartment walls and floors 18; service openings 939  
 competent persons 65, 66  
 component drawings 21  
 component symbols 43  
 composite boards 860–1  
 composite joists 657  
 composite lintel 428  
 composite timber beams 655  
 compressed air caissons 338  
 compressed strawboard 860  
 compression arch 10  
 compression joints 904  
 compression tests: mortars 423; soils 106, 107  
 compressive strength: bricks 381, 418; mortars 418, 423  
 concealed spaces, fire-resisting construction 849  
 concoids 687  
 concrete: batching 327–8; curing 240; discoloration 725; foundations 250; materials 325; mixes 250, 330–1;

- placing 238–9, 594; in situ tests 137–9; specification 330–1; strength 329–30; supply 332; surface defects 725; surface finishes 721–5, 766; thermal performance 551; transporting 233, 236–7; water/cement ratio 328–9; wet testing 135–6; *see also* in-situ concrete; precast concrete; prestressed concrete; reinforced concrete
- concrete bed/slab 253; column base connections 635; solid ground floors 759; thermal performance 551, 552, 553–4; *see also* reinforced concrete slabs
- concrete block permeable paving (CBPP) 875
- concrete blocks: sound insulation 797, 798; weights 38
- concrete cladding panels 714–20
- concrete flagstones, weight 38
- concrete flat roofs, thermal insulation 571
- concrete floor screeds 768–9; domestic ground floors 763; sound insulation 799; thermal performance 552
- concrete hyperbolic paraboloid shells 690
- concrete mixers 234–5
- concrete pumps 237
- concrete shell roofs 684
- concreting plant 233–9
- condensation control: aluminium casement windows 454; roof space ventilation 540
- condensing boilers, CO<sub>2</sub> reduction 568
- conduit culvert 339
- conduits (electrical) 921
- conical membrane structures 693
- conoid shells 9
- conservation areas 152; demolition 195
- conservatories 69
- consistency class (concrete) 331
- construction activities 19–20
- construction defects 28
- Construction (Design and Management) (CDM) Regulations 1997 54, 55
- construction details 71
- Construction (Head Protection) Regulations 1998 54
- Construction (Health, Safety and Welfare) Regulations 1996 54
- Construction Industry Research and Information Association (CIRIA) 77
- Construction Industry Scaffolders Registration Scheme (CIRS) 185
- Construction Information Service (CIS) 83
- construction joints 734; *see also* movement joints
- Construction Product Information Committee (CPIC) 80
- Construction Products Regulations (CPR) 75
- construction programme 37
- construction regulations 54
- construction site *see* site
- consumer units 919–20
- contaminated soil 365–6
- contiguous piling 355
- continuous column foundations 262
- continuous flight auger bored piles 272–3
- continuous slab stairs 814
- contour plasterboard 753
- contract bills 20
- contract documents 20
- contraction joints *see* movement joints
- controlling dimensions 53
- controlling grid 52
- controlling lines 53
- controls, hot water heating systems 916
- control valves 901
- cooker circuits 923
- Coordinated Product Information (CPI) 79
- coping, walls 404
- copper covered roofs 872
- copper damp-proof courses 409
- corbels 397–8
- core drilling 98
- core structures 659–60
- corner posts 445
- cor-ply beams 655
- corrugated materials, storage on site 131
- corrugated metal sheet roofing 665
- costing, plant 203
- Coulomb's wedge theory 303
- counter, purpose-made 855
- couple roof 496
- cover flashing 935
- CPIC (Construction Product Information Committee) 80
- CPI (Coordinated Product Information) 79
- CPI system of coding 79
- CPR (Construction Products Regulations) 75
- cracking: paintwork 853; in walls 249
- crack monitoring 249
- cranes 221–32
- crane skip dumper 236
- cranked slab stairs 814, 820
- crawler cranes 225
- crazing: concrete 725; paintwork 853
- crib retaining walls 299
- cross-cut saws 854
- crosswall construction 471–4
- culverts 339–40
- curing of concrete 240



- curtain walling 708, 710–13; thermal performance 585
- curved valley tiles 505, 512
- cut-and-cover 339
- cut-and-fill 319
- cut tile cladding 487
- dado rails 857
- damp-proof courses (dpc) 408–14; bridging of 411–12; cavity walls 403; chemical 411–12; chimney stacks 936; insulating 414; openings 428, 429; *see also* cavity trays
- damp-proof membranes (dpm) 408–14, 759
- data management 81
- datum 158
- DC (Draft for public Comment) 73
- DCLG (Department for Communities and Local Government) 34, 62, 71, 72, 76
- DD (Draft for Development) 73
- dead shoring 186, 187
- death-watch beetle 544
- decking, timber flat roofs 527
- decorative suspended ceilings 848
- decorative tiles 486
- deep basement construction 309
- deep strip foundations 251, 262
- defects *see* construction defects; paint defects
- demolition 195–9; rubble shutes 220; sustainable 199
- demountable partitions 744–5
- dense monolithic concrete 313
- densities of materials 39, 551–2; concrete materials 328; stonework 371
- dentil coursing 398
- Department for Business Enterprise and Regulatory Reform (BERR) 76
- Department for Communities and Local Government (DCLG) 34, 62, 71, 72, 76
- deposit of plans 64, 68
- DER (dwelling emission rate) 33, 567
- designated mix (concrete) 330
- designed mix (concrete) 330
- dewatering 349
- diagonal braced structure 660
- diaphragm valve 901
- diaphragm walls 406; deep basements 309–12; ground water control 356–7
- diesel hammers 284
- differential movement 735
- dimensional changes in timber 148
- dimensional coordination 53
- dimensional grids 53
- direct cold water systems 894
- direct hot water systems 896
- disability access *see* access for the disabled
- discharge stacks, airtightness testing 912
- discoloration of concrete 725
- displacement piles 274–6, 354
- display windows 585
- ditches 876
- documentation 20; coding systems 78–80, 82–3
- dog leg stairs 811, 812
- dog tothing 398
- dome rooflights 698
- dome structures 9
- door frames: external 465; internal 836
- door heads 465; thermal performance 580, 581
- door jambs 465; thermal performance 580, 581
- doors: draughtproofing 583; frames 465, 836; industrial 471–4; ironmongery 466; performance requirements 462; swings 41; thermal performance 560, 562, 585; types 463–4; *see also* external doors; internal doors
- doorsets 837
- door threshold 431
- dormer windows 537–9
- double acting hammers 284
- double action floor spring 843
- double conical membrane structures 693
- double curvature shells 9
- double glazing 435, 450; CO<sub>2</sub> reduction 568; sound insulation 450; thermal performance 561
- double hung sliding sash 433, 439, 441
- double lap tiles 505–6
- double lap tiling 507–8, 512–13
- double layer grid 682
- double skin roof coverings 668
- double swing doors 843
- Douglas fir 858
- dowelled lattice steel beams 632
- downpipes 879
- dpc *see* damp-proof courses (dpc)
- dpm *see* damp-proof membranes (dpm)
- Draft for Development (DD) 73
- Draft for public Comment (DC) 73
- draglines 212
- drainage 868–91; access points 888; combined system 883, 884; foul water 868, 881; separate systems 882, 884; stack discharge systems 908–11; subsoil water 869–70; surface water 871–80; surveys 30
- drainage pipes 891; storage on site 131
- drained cavity system 317
- drained joints 717–18

- drains: access points 888; inspection chambers 886–7; laying 889; rainwater 879–81; testing 890
- draughtproofing 568, 583
- draught sealers/stops 434; doors 465; sash windows 439, 440
- drawings 20–7; hatchings, symbols and notations 41
- Drawings Code 79
- dressed stone 377, 378; *see also* ashlar
- driers, paint 850
- drinking water on site 124
- driven piles *see* displacement piles
- drop arch 425
- drop hammers 283
- dry dash 480
- dry lining 583, 750–2
- dry rot 149, 150
- dumpers 215, 236
- Durgo valve 910
- Dutch bond 387
- dwelling emission rate (DER) 33, 567
- dynamic compaction 363
- earth monitor unit (EMU) 121
- earth moving equipment 205–13
- earth pressures, retaining walls 290, 302–3
- earthworks: road construction 165; *see also* embankments; excavations
- eaves detail: double lap tiling 507, 508; roof sheet coverings 667, 669; single lap tiling 515; single ply roof membranes 536; slating 516; sprocketed eaves 503; timber flat roofs 523, 530
- eaves gutters 878
- eaves tiles 505
- eaves vents 508, 541
- economic considerations, plant 202
- edge beams: framed construction 7; raft foundations 260
- edgings, paving 169
- effective column length: reinforced concrete columns 603; structural steel columns 645
- effluent 868
- elastomers 863
- electrical accessories 923, 925
- electrical cables 921, 923; holing and notching for 780–1
- electrical supply 917–20; to building site 121; intake details 917–18
- electrical symbols 43
- electrical wiring 922
- electricity meters 919
- electrolysis 366
- electronic communications 941
- elements of construction, U-values 560–1, 585
- elevations, drawings 21, 26
- embankments: cutting, shaping and grading 207; soil nailing 300
- emergency escape *see* escape from fire
- emissivity 550
- EMJA (English Joinery Manufacturers Association) 435, 436
- EMU (earth monitor unit) 121
- encapsulation of contaminated soil 366
- end bearing piles 266
- energy efficiency: accredited construction details 71; hot water and heating systems 565; potential CO<sub>2</sub> reduction 568; rating 559, 566; *see also* thermal performance
- Energy Performance Certificates (EPC) 32–5
- EN (European Standards) 74
- engineering bricks: compressive strength 381; damp-proof courses 410
- engineers' drawings 20
- English bond 384
- English cross bond 386
- English garden wall bond 386
- English Joinery Manufacturers Association (EMJA) 435, 436
- entrances: access for the disabled 586, 588; thermal performance 585
- Environment Act 1995 365
- environmental considerations 3
- environmental performance 72; *see also* energy efficiency; thermal performance
- Environment Protection Act 1990 365
- EOA (extension outlet assembly) 121
- EPC (Energy Performance Certificates) 32–5
- EPDM (ethylene propylene diene monomer) roof coverings 535
- EPIC (Electronic Product Information Cooperation) 80, 82
- epoxy resin injection mortars 412
- EPS (expanded polystyrene) board 552, 763
- escape from fire: escape signs 56; escape stairs 823; escape windows 432; fire doors 838–42; public stairs 832
- ETAs (European Technical Approvals) 75
- ethylene propylene diene monomer (EPDM) roof coverings 535
- EU energy rating 33
- European spruce 858
- European Standards (EN) 74
- European Technical Approvals (ETAs) 75
- European Window Energy Rating Scheme (EWERS) 566

- excavating machines 209–13, 307
- excavations 319–24; basements 304–7; drains 889; ground water control 324, 350–9; processes 321; setting out 155–7; steel sheet piling 334–5; temporary support 322–4; water in 319; *see also* trenches
- expanded polystyrene (EPS) board 552, 763
- expansion joints *see* movement joints
- explosives (demolition) 198
- exposed aggregate finishes 722
- extension outlet assembly (EOA) 121
- extensions *see* building extensions
- exterior of building, surveys 30
- external doors: frames 465; performance requirements 462; types 463–4
- external envelope: accredited construction details 71; choice of materials 370; functions 17; thermal bridging 580–2
- external surface resistance 550
- external walls 389; cladding 482–9; rendering 479–81; thermal insulation 572–8, 585; thermal performance 550–1, 555–6, 560, 585
- extrados 424
- extruded brick 395
- eyebrow dormer window 539
  
- fabric membranes 694
- face grid 53
- face shovels 210
- Factories Acts 1937/1961 54
- falsework 610
- fascias 507, 508, 515
- fencing, site 113
- fibreboards 861; thermal performance 551
- filing systems 78–80
- filled welds 636
- fine aggregate 325
- finger joints 651
- finishes *see* surface finishes
- finishing coats 851
- finned walls 405
- firecheck plasterboard 753
- fireclay sinks 905
- fire compartmentation *see* compartment walls and floors
- fire doors 838–42
- fire/emergency escape signs 56
- Fire Officers' Committee (FOC) 76
- fire protection: reinforced concrete 609; service openings 939; structural steelwork 638–9; stud partitions 743
- fire-resisting construction: concealed spaces 849; fire doors 838–42; internal doors 835; party/separating walls 738; plasterboard linings 743; timber upper floors 782–3
- fire safety, public stairs 832
- fire separation 18
- fire stopping 939; *see also* cavity barriers
- firings, flat roofs 522
- first aid 123
- fitment symbols 43
- fixed lights (windows) 433
- flaking, paintwork 853
- flashings: chimney stacks 935, 936; concrete claddings 718; roof abutments 513; vent pipes 911
- flat roofs 491; garage attachments 391; thermal insulation 571; timber 522–36
- flats, separation and compartmentation 18
- flat top girders 673
- flaunching 936
- Flemish bond 385
- Flemish cross bond 387
- Flemish garden wall bond 386
- flexible paving 165
- flitch beams 655
- float glass 448
- floating floors 13, 799, 800–1, 849
- floating piles 266
- floating screeds 769
- float valves 901, 902, 907
- flood prevention 874
- floor area, building control exemptions 69
- floorboards 765
- floor finishes 14, 764–5; suspended concrete floors 761, 763
- floor plans and elevations 21, 26
- floors: imposed loads 15, 40; sound insulation 799–802; surveys 31; thermal performance 550, 552, 560, 585; *see also* ground floors
- floor screeds *see* concrete floor screeds
- floor tiles 764
- floor traps 13
- flow controls, hot and cold water installations 901
- flues 930, 933–4; gas fires 929; liners 934, 935; pumice chimney blocks 938; trimming around 775
- flush bored piles 267, 269
- flush doors 463, 834, 835
- flying shoring 186, 189–91
- fly jib attachment 224
- FOC (Fire Officers' Committee) 76
- folded plate construction 8, 692
- folded slab roofs 692
- folding partitions 745
- folding shutter 467, 470
- footpaths 168

- fork lift trucks 216
- formation level 319
- forming piles 268
- formwork 610–16; in-situ reinforced
  - concrete stairs 818; metal section (MetSec) decking 595; retaining walls 294–6; simply supported RC slabs 594; striking times 612
- foul water 868
- foul water drainage 881
- foundations 244–86; design principles 261; loads 244; materials 250; piled 266–86; precast concrete frame connections 618, 648; setting out 155–7; sizing 254–6; soil investigation 95; structural steel base connections 635, 649; subsoil movements 246–8; types 251, 261–5; underpinning 341–8; *see also* substructure
- framed construction 7; brick infill 699; infill panel walls 701–4; loads 16; precast concrete 617–20; setting out 156; steel framed 477–8; *see also* timber frame construction
- framed ledged and braced doors 463
- frames: external doors 465; internal doors 836
- free-hand sketches 22
- French drain 869, 876
- Freyssinet anchorage 625
- friction grip bolts 637
- friction piles 266
- Frodingham box pile 278
- Frodingham sheet pile 334, 336
- frost heave 245
- fuels, CO<sub>2</sub> conversion factors 567
- full height casting 294
- full planning application 45, 68, 70
- fungal decay 149–50
- furniture beetle 544
  
- gabion wall 301
- gable ended dormer 538
- gable end roof 492; *see also* abutment details
- galvanised corrugated steel roofing 665
- gambrel roofs 501
- gantries 184
- gantry cranes 226
- gantry girders 630
- garage attachments 391
- gas-fired boilers, energy efficiency 562
- gas fires 928–9
- gasket joints 719–20
- gas-resistant membranes 415–16
- gas supply 926–7
  
- gate valve 901
- gauge box 327
- geodesic frame 682
- Georgian style door 464
- geo-technical survey 365
- girders, roof 673–4
- glass 448; low emissivity 453, 455
- glass blocks 460–1; density 38
- glazed doors: external 464; internal 834, 843
- glazed wall tiles 756
- glazing 449–59; fire doors 842; manifestation 459; patent glazing 695–6; protection against impact 458–9; rooflights 695–7; terminology 448; thermal performance 560
- glazing bar 439
- Gluelam *see* laminated timber
- gluing, laminated timber 653
- going (stairs) 804
- graders (machines) 207
- gradients *see* sloping sites
- granite, sources 372
- granolithic finish 723
- graphical symbols 56–7
- gravel soils: angles of repose 322; foundations 255; investigation 100–1; thermal conductivity 552
- green-field development 365
- greenhouses 69
- green roofs 546–7
- 'green' star rating 72
- grid construction 10
- grids, setting out 156
- grinding, concrete 721
- grinning, paintwork 853
- grip length, reinforced concrete 599
- ground anchors 309, 627
- ground bearing capacity 244, 254
- ground-bearing concrete: domestic ground floors 758; thermal insulation 553, 579; thermal performance 553–4
- ground drains 869–70
- ground floors 758–63; thermal bridging 580; thermal insulation 579, 581
- ground freezing techniques 359
- ground investigation 92–8
- ground levels 158–60
- ground movement 245; *see also* settlement; underpinning
- ground vibration 361
- ground water control 349–59; permanent exclusion 354–8; temporary exclusion 350–2
- grouted membranes 354
- grouting: ground water control 358; wall tiles 757

- grout injecting piling 273
- gullies 873, 877, 879
- gusset base 635
- gusset plates 664, 667
- gutters 872, 878
- gypsum plaster 746; thermal performance 551
  
- half bonding 383
- half round roofing tiles 505, 512
- handheld lamp 120
- handrails 804, 806, 826, 828
- hangers: suspended ceilings 845, 846, 847; timber roofs 497
- hardcore, solid ground floors 759
- hardwood floors, thermal performance 552
- hardwoods 859
- harmonised European product standards (hENs) 75
- hatchings (drawings) 42
- hazard signs 56–7
- headers 383
- head lap 517, 518
- heads (opening support) 428, 431; doors 465; sash windows 439; thermal bridging 580; thermal insulation 581
- head (water pressure) 894
- health and safety 54–7; excavations 323; hoists 219; hot water temperatures 899–900; legislation and regulations 54–5; personal protective equipment (PPE) 125; protection against impact 458–9; public stairs 827–32; scaffolding 185; site health and welfare provision 123–4
- Health and Safety at Work, etc. Act 1974 54, 56
- Health and Safety (Safety Signs and Symbols) Regulations 1996 56
- hearth 932–3, 937
- heating systems: central heating 897; commissioning 565; energy efficiency 565
- heave 246–8
- helical stairs 816
- hemispherical rotational dome 9
- hENs (harmonised European product standards) 75
- herringbone strutting 772
- high rise buildings *see* tall buildings
- highway drainage 876–7
- highway dumper 215
- Highways Act 1980 45; demolition 195, 220; hoardings 116
- hinges, precast concrete frame connections 648
- hip detail: roofing tiles 512; slating 519
- hip end dormer 538
- hipped end roof 492
- hip rafter 495
- hip tiles 505, 512
- hiring plant 203
- hoardings 113, 116–17
- Hoffmann kiln 380
- hoists 217–19
- holding down bolts 618
- holing for pipes and cables 780–1, 922
- holing gauge (slates) 517
- hollow core aluminium casement windows 454
- hollow pot floors 787, 793
- honeycomb bond 760
- horizontal pivot (window) 433
- horizontal sliding sashes 433, 443, 451
- horn (window): casement windows 434; sash windows 439, 440
- hot rolled steel 629
- hot water heating systems 896–903, 913–16; commissioning 565; controls 916; energy efficiency 565; flow controls 901; temperatures 899–900
- hot water storage cylinders 896, 903; CO<sub>2</sub> reduction of insulation 568
- House Longhorn beetle 544, 545
- houses *see* domestic structures; dwellings
- ‘H’ section piles 278
- hull core structure 660
- hydration, concrete 240
- hydraulic jacks 344
- hyperbolic paraboloids 9, 688–90, 693
  
- igneous rocks 371
- immersion heaters 903, 923
- impact hammers 198
- incineration, contaminated soil 367
- inclined slab stair 814, 817
- incoming site assembly (ISA) 121
- independent scaffolds 174
- indirect cold water systems 895
- indirect hot water systems 897, 903
- industrial doors 467–70
- inert gas double glazing fill 455
- infestation control 544–5
- infill panel walls 701–4
- information management 81
- injection mortars 412
- insect damage control 544–5
- in-situ concrete ground floors 759; large cast ground floors 766–7; thermal performance 552, 554
- in-situ concrete piles 282, 355
- in-situ concrete walls: formwork 615–16; sound insulation 797

- in-situ piles 281
- in-situ reinforced concrete framed structures 596, 600
- in-situ reinforced concrete stairs 814–18
- in-situ reinforced concrete suspended floors 784–8
- in-situ reinforced concrete walls: ground water control 356; retaining walls 294–6
- inspection chambers 886–7, 888
- installer notification 66
- institutional stairs 827
- insulation *see* thermal insulation
- insurance, demolition cover 197
- interlocking piles 355
- internal block walls 732–3; sound insulation 796, 797
- internal brick walls 731, 733; sound insulation 797
- internal compartmentation 18
- internal doors 833–7; doorsets 837; fire and smoke resistance 841; fire doors 838–42; frames 836; performance requirements 462; vision panels 842
- internal dormer 538
- internal elements 728
- internal floors: sound insulation 796; *see also* reinforced concrete suspended floors; separating floors; suspended timber floors
- internal partitions 739–45; demountable 744–5; fire protection 743; sound insulation 796
- internal party walls 737–8
- internal separation 18
- internal surface resistances 550
- internal walls 729–38; demountable partitions 744–5; fire protection 736; plaster finish 747–8; sound insulation 796–8, 802; stud partitions 740–3; *see also* masonry walls; separating walls
- International Standards (ISO) 74
- intersecting barrel vaults 687
- intrados 424
- intumescent seals 841, 842, 939
- inverted warm decks 525, 528
- iroko 859
- ironmongery: doors 466; windows 438
- iron, painting 852
- ISA (incoming site assembly) 121
- ISO (International Standards) 74
- isometric projections 23
- jack pile underpinning 344
- jack rafter 502
- jamb 429, 431; door frames 465; sash windows 439; thermal bridging 580; thermal insulation 581
- Jarrah 859
- jet grouting 364
- jetted sumps 351–2
- joinery: purpose-made 855–6; storage on site 131; timbers 858
- joinery production 854–9
- jointless suspended ceilings 846
- joints: basement construction 314; brickwork 392–4; concrete cladding panels 717; drains 889; lead sheeting 532–3; mortar 393; plasterboard 755, 844; tolerances 394; water pipework 904
- joist hangers 773, 775
- joists: holing and notching 780–1; notched 779–81; sizes 526, 776–8; steel 629; steel web lattice 657; suspended timber floors 760, 771; timber flat roofs 523–6
- kelly bars 271, 272, 356
- kerbs 169, 876
- key brick/stone 424, 425
- kilns, brick 380
- king closers 395
- kitemark 73
- knotting 851
- krypton double glazing fill 455
- laboratory tests: aggregate 134; soils 107
- laced valley 520
- laminated timber 651–4, 860
- laminboard 860
- land caisson 337
- landings: concrete stairs 817, 820; metal stairs 823; timber stairs 807, 811–12
- land reclamation 365–7
- landscaping 171
- lantern lights 697
- lap (tiling) 507
- Larssen sheet pile 334, 336
- lateral restraint: precast concrete floors 791; timber suspended upper floors 773–4
- latex floor screeds 770
- lattice core door 835
- lattice steel beams 632
- lattice timber frame 655
- lawful development certificates (LDC) 46
- LDPE (low density polyethylene) damp-proof courses 409
- lead: damp-proof courses 409; sheet materials 531–2; working tools 533
- lead covered roofs 532–4, 872
- lead flashing *see* flashings

- 'lead slate' weathering 911
- lean-to garage attachments 391
- lean-to roof 496, 540
- ledged and braced doors 463
- Legionella* 899
- legislation 45; contaminated land 365
- lens lights 697
- letter plate 466
- levelling 159
- lift access for the disabled 589
- lift casting 295
- Lifting Operations and Lifting Equipment Regulations (LOLER) 1998 54, 219
- light bulbs, energy saving 568
- lighting circuits 923, 925
- lighting, site 119–20
- lightweight aggregate blocks: fire resistance 736; sound insulation 797, 798
- lightweight aggregates 325
- lightweight infill panels 703–4
- lightweight pumice chimney blocks 938
- lime bloom 725
- lime mortar 422
- limestone: ashlar 374; sources 372
- lines (drawings) 41
- lining boards 750–3
- linings: flues 934, 935; internal doors 833, 836; sash windows 439, 440
- linseed oil putty 449
- lintels 428; internal walls 731, 732; thermal insulation 581
- liquid limit, soils 110
- listed buildings 152; demolition 195; Energy Performance Certificates (EPC) 32
- Litzka beam 631
- load bearing capacity, subsoil 244, 254
- load bearing concrete panels 714
- load-bearing partitions 739
- load-bearing walls: external 251; internal 730, 731, 732
- loaders 208
- loads: domestic structures 15; foundations 244, 254–6; holing and notching in timber joists 780–1; openings 424; reinforced concrete beams/slabs 592, 598; structural steel beams 640–3; temporary support 192–4; timber beams 777–9
- local authority building control 65, 66, 67
- local materials 372
- location drawings 21
- loft hatches: draughtproofing 583; thermal performance 558
- loft insulation, CO<sub>2</sub> reduction 568
- LOLER (Lifting Operations and Lifting Equipment Regulations) 1998 54, 219
- Longhorn beetle 544, 545
- long span roofs 670–8
- loop-in method 925
- lorry mounted concrete pump 237
- lorry mounted cranes 223–4
- Loss Prevention Certification Board (LPCB) 76
- Loss Prevention Council (LPC) 76
- louvred doors 834
- louvre windows 433
- low carbon home 72
- low density polyethylene (LDPE) damp-proof courses 409
- low emissivity glazing 453, 455
- LPCB (Loss Prevention Certification Board) 76
- LPC (Loss Prevention Council) 76
- luffing jibs 227
- luminaires in suspended ceilings 847, 848
- lyctus powder beetle 544
- Maguire's rule 891
- mahogany 859
- main distribution assembly (MDA) 121
- mains fed indirect hot water systems 898
- maintenance of plant 202
- maisonnettes, compartmentation 18
- Management of Health and Safety at Work Regulations 1999 54, 56
- manholes 886, 888
- manifestation (glazing) 459
- mansard roof 493
- marble, sources 372
- margin (slating) 517
- masonry cement 422
- masonry diaphragm walls 406
- masonry fin walls 405
- masonry partitions 739
- masonry units: retaining walls 297–8; site tests 132; *see also* blocks; bricks
- masonry walls: calculations 417–20; construction joints 734; fire protection 736; internal 731–8; opening details 428–31; reinforced bed joints 735; tolerances 407; *see also* blockwork; brickwork
- mass retaining walls 291–2
- mast cranes 227
- mastic asphalt: damp-proof courses 410; roof covering 522, 530; roof drainage 872; tanking 315–16
- mastics 863
- matchboarding 482
- materials *see* building materials
- materials testing 132–42
- mathematical tiles 488
- mattress wall 301

- MC *see* moisture content (MC)  
 MDA (main distribution assembly) 121  
 MD Insurance Services 67  
 measured surveys 87–9  
 mechanical float 239  
 meeting rails 439, 440  
 membrane construction 10  
 membrane roof structures 693–4  
 membranes: gas-resistant 415; ground water control 354; roofing 504, 510; single ply roof coverings 535; *see also* damp-proof membranes (dpm); vapour control layers  
 MERO system 681  
 metal casement windows 437  
 metal covered roofs 532–4, 665, 872  
 metallised polyester wall board 753, 844  
 metal section (MetSec) decking 594, 595, 793  
 metal sinks 905  
 metals, painting 852  
 metal stairs 823–5  
 metal stud partitions 742  
 metamorphic rocks 371  
 methane 415  
 method statements 36  
 MetSec (metal section) decking 594, 595, 793  
 micro bore systems 915  
 milled lead sheet 531  
 mineral insulated cable 921  
 mineral wool insulation: thermal performance 552; U-values 571, 573  
 mitre cut valley 520  
 mitred hips 519  
 mix ratio (concrete) 250, 331  
 mobile cranes 221  
 mobile scaffolds 177  
 modified plasticity index (MPI) 110  
 modular coordination 52–3  
 moisture content (MC): soils 109–11; timber 148, 651  
 moisture resistant plasterboard 753, 844  
 monitor roofs 672  
 monk bond 387  
 monogroup cable 622  
 monolithic caisson 337  
 monolithic screeds 768  
 monopitch roof 492, 540  
 monostrand anchorage 625  
 monostrand cable 622  
 mortar joints 393  
 mortars 422–3; additives 422; chimney stacks 936; classification 423; compressive strength 418, 423; glass block walling 461; mixes 423; renders 479, 481  
 mortice lock 466  
 morticing machines 854  
 moulding profiles 857  
 moulds, brick making 379  
 movement: cracking in walls 249; subsoil 245–8; thermal 532  
 movement joints 392; barrel vaults 686; brickwork cladding 700; masonry 734, 735; road construction 167  
 MPI (modified plasticity index) 110  
 mud-rotary drilling 98  
 mullions 434, 445  
 multiple glazing 455–7; thermal performance 561  
 multi-purpose excavators 213  
 multistorey buildings *see* tall buildings  
  
 NASC (National Access and Scaffolding Confederation) 185  
 National Access and Scaffolding Confederation (NASC) 185  
 National Building Specification (NBS) 79, 83  
 National Calculation Methodology (NCM) 584  
 National Engineering Specification (NES) 83  
 National House-Building Council (NHBC) 67  
 natural environment 2  
 NBS (National Building Specification) 79, 83  
 NCM (National Calculation Methodology) 584  
 needle and pile underpinning 345  
 needle design 192–3  
 neoprene gaskets 711  
 NES (National Engineering Specification) 83  
 new build: energy performance 562, 563; planning applications 49–50  
 newel posts 806–7, 812  
 NHBC (National House-Building Council) 67  
 nibblers 198  
 Nordus system 683  
 northlights 670, 671, 687  
 nosings (stairs) 804, 805, 827  
 notations (drawings) 41  
 notched timber joists and beams 779–81, 922  
  
 oak 859  
 OD (Ordnance Datum) 158  
 oil-based paints 850  
 oil-fired boilers, energy efficiency 562, 568  
 OPC (Ordinary Portland Cement) 325  
 open caisson 337  
 open ditches 876



- open drained joints 717–18
- open excavations, basements 304
- open fireplaces 930–8; chimneys and flues 933–6; combustion air 937
- openings: draughtproofing 583; heads 428; jambs 429; loads 424; in precast concrete floors 791; sills 430; sizing 390, 562; supports over 424–31; upper floor trimming 775; *see also* service openings
- open newel stairs 811
- open riser stairs 808–9
- open suspended ceilings 848
- open web steel beams 631
- operational rating 33
- Ordinary Portland Cement (OPC) 325
- Ordnance Datum (OD) 158
- orientation of building 3
- oriented strand board (OSB) 527, 861
- orthographic projections 23
- OSB (oriented strand board) 527, 861
- outline planning application 45
- out of service position (cranes) 228
- overcloak (lead sheeting) 533
- overhead fork lift 216
- overload protection 920
- oversailing course 936
- over-site concrete 253
- oversite (excavations) 319
- overturning (demolition) 198
- oxidation, contaminated soil 367
  
- pad foundations 252, 263; setting out 156; soil investigation 95
- paint brushes 851
- paint defects 853
- painting 851–3
- paint rollers 851
- paints 850–1
- paint sprays 851
- panel construction 8; diaphragm walls 357; infill panel walls 701–4
- panelled doors 463
- panelled suspended ceilings 847
- panelling, purpose-made 856
- parallel lay cable 622
- parallel strand beams (PSB) 656
- Parana pine 858
- parapet gutter 872
- parapet walls 404
- parking for the disabled 587
- particle boards 861; cement bonded 527; flat roof decks 527; floor finishes 765; thermal performance 552
- particle size distribution, soils 100
- parting bead 439, 440
- parting slip 440
- partitions, internal *see* internal partitions
- party walls 737–8; thermal performance 560, 561
- PAS (Publicly Available Specification) 73
- passenger hoists 218
- patent glazing 695–6
- patent scaffolding 179
- pattress plates/straps 774
- paving: drainage 873; footpaths 168; permeable 875; road construction 165–7; specification 330; typical weights 38
- paving channels 169, 873
- paving flags 170
- PD (Published Document) 73
- pebbledash 480
- peeling of paintwork 853
- peg tiles 506
- pendants, stairway 807
- pendentive dome 9, 684
- penetration test, concrete 138
- percussion bored piles 267, 268
- percussion driven piles 274–85
- perforated steel beams 631
- performance rating 32–3
- performance standards 71
- perimeter trench excavations 305
- permeable paving 875
- permitted development 46–7
- personal protective equipment (PPE) 125
- perspective projection 25
- phenol formaldehyde 654
- phenolic foam board, thermal performance 552
- physical considerations 4
- phytoremediation 367
- pictorial symbols 56–7
- picture rails 857
- piered walls 389–90, 420–1
- pier holes 320
- piers: brick 389, 417; calculations 417; vertical strut 5
- pigments 850
- pile caps 286
- piled basements 308, 355
- piled foundations 266–86; classification 266; displacement piles 274–85; replacement piles 267–73; short bored piles 259; and subsoil movements 247, 248; testing 286
- piling hammers 283–5
- pillar tap 901
- pipe culverts 339
- pipeline identification 56
- pipe sizing, drainage pipes 891

- pipework: holing and notching for 780–1; service openings 939
- pipework joints 904
- PI (plasticity index) 109
- PIR (polyisocyanurate foam) 509
- pitched trusses 671; steel 663–4
- pitch line (stairs) 804
- pitch pine 858
- pitch polymer damp-proof courses 409
- pit excavations 321
- pivot windows 444
- plain tiles 505
- plane frame 6
- planers 854
- planing, laminated timber 652
- plank plasterboard 753
- planning applications 45–51
- planning grid 52
- Planning (Listed Buildings and Conservation Areas) Act 152; demolition 195
- plans 44
- plant: maintenance of 202; planning for 113
- plasterboard: ceilings 783, 844; dry lining 750; edge profiles 750; fire resistance 743; fixing 754, 844; jointing 755; plaster finish 748; sound insulation 798; thermal performance 551; types 753
- plaster finish 747–8; painting 852; *see also* gypsum plaster
- plastic inspection chambers 887
- plasticisers 422
- plasticity index (PI) 109
- plastic limit, soils 110
- plastics 862
- plate girders 632
- plate loading (bearing) test 102–3
- platform frame 475
- platforms, working 175
- plinths 397
- plywood 860; flat roof decks 527; linings 752; thermal performance 552
- plywood faced lattice 650
- pneumatic caissons 338
- pockets, sash 439
- pointing 393
- poker vibrators 238, 362
- poling board 324
- Pollution Prevention and Control Act 1999 365
- polyisocyanurate foam (PIR) 509
- polymer membranes 535, 694
- polymer renders 481
- polypropylene: cavity trays 427; damp-proof courses 409
- polypropylene ventilator 761
- polysulphide sealant 864
- polyurethane board, thermal performance 552
- polyurethane sealant 864
- polyvinyl acetate (PVA) 481
- polyvinyl chloride (PVC): floor tiles 764; roof coverings 535
- porches 69
- portable cabins 122
- portable toilets 123
- portal cranes 226
- portal frames 646–50
- Portland cement 325; mortar 422
- Portsmouth floatvalve 901
- post and lintel 6
- post and panel diaphragm wall 357
- post-tensioned reinforced concrete 330, 624–5
- post-tensioned retaining wall 298
- power float 239
- power ring circuits 923
- power sockets 924
- PPC Regulations 2000 365
- PPE (personal protective equipment) 125
- practice accreditation 76–7
- precast concrete: blocks 399; coping 405; pre-tensioning 623
- precast concrete crosswall construction 473–4
- precast concrete diaphragm walls 357
- precast concrete floors 761–3, 789–93; sound insulation 796, 799
- precast concrete frames 617–20, 647
- precast concrete panels 701, 714–20
- precast concrete stairs 819–22
- prefabrication: precast concrete crosswall construction 473–4; steel frame construction 477–8; timber frame construction 475–6
- preformed concrete piles 276, 280
- preliminary sketches 21
- prescribed mix (concrete) 330, 331
- preservatives, timber 150, 654
- pressed brick 395
- pressed steel lintel 428
- pressure bulb 94–5
- prestressed concrete 621–7
- prestressed concrete beams, suspended concrete floors 761, 762
- prestressed lintels 428
- pre-tensioned reinforced concrete 330, 623
- primatic cylinders 903
- priming coats 851
- private sector building control 65, 67
- product certification 33, 76–7
- product coding 78–80
- productivity, plant use 204

- profiled concrete 721
- profiled metal roof coverings 665–9
- project documentation 20
- project information: building information modelling (BIM) 81–4; coding systems 78–80, 82–3
- project plans 37
- proportional area method (U-values) 555, 557
- propped cantilever 5, 661
- protected buildings *see* listed buildings
- protected shafts 18
- protected stairwells 18
- PSB (parallel strand beams) 656
- Public Health Act, demolition 195
- Publicly Available Specification (PAS) 73
- public sewer 885
- public stairs 827
- public utility services 153; electrical supply 917–19; gas supply 926; sewers 881, 885; water supply 892–3
- Published Document (PD) 73
- pugging 801
- pulley head 439, 440
- pulley stile 439, 440
- pull-out test 138
- pumice chimney blocks 938
- purlins: roof sheeting fixings 666; timber pitched roofs 495, 497
- pusher arms 198
- push-up structures 662
- putlog scaffolds 173
- putty 449
- PVA (polyvinyl acetate) 481
- PVC *see* polyvinyl chloride (PVC)
- Pynford stool underpinning 346
- pyramid rooflights 698
- pyrites 725
  
- quadrant stay 438
- quality assurance 76–7
- quality control 28
- quarried stones 372–3
- quarter bonding 383
- quarter space landing stair 811
- queen closers 382, 384, 395
- quoins 382
  
- radon gas 415
- rafters 495, 497
- raft foundations 95, 260, 264
- rail mounted cranes 228, 231
- rain resisting construction 408; openings 431; sills 430; stonework 378; windows 435; *see also* weathering details
- rainscreen cladding (RSC) 577–8, 701, 705–7
- rainwater drainage 872–80
- rainwater gutters 872, 878
- rainwater pipes 878–9
- rainwater soakaways 880, 882
- raised flooring 794
- raking shoring 186, 188, 305
- raking stretcher bond 387
- random rubble 376–7
- rapid hardening cement 325
- rat trap bond 386
- RCD (residual current device) 920
- ready mixed concrete 236, 332
- ready mixed mortar 423
- rebates, glazing 448, 449
- rebound hammer test 137
- reconstituted stone 373
- rectangular pad foundations 263
- recycling of demolition waste 199
- reduced level excavations 319, 321
- redwood 858
- refurbishment, Energy Performance Certificates (EPC) 32
- regulations 54
- reinforced concrete: bar schedule 605; bar spacing 601; binders/links 601, 608; compared with prestressed concrete 626; concrete cover 608; fire protection 609; grip length 599; reinforcement 593, 605–7; retaining walls 292–6; spacers 594, 608; specification 330; *see also* in-situ reinforced concrete; precast concrete; prestressed concrete
- reinforced concrete beam and slab raft 251, 264
- reinforced concrete beams: bar spacing 601; beam to column connection 620; fire protection 609; fixings 788; formwork 611–12; simply supported 596–8
- reinforced concrete cladding panels 714–20
- reinforced concrete columns 600, 601–3; bar spacing 601; beam to column connection 620; clamps and yokes 614; column to column connection 619; fire protection 609; formwork 613–14; precast 618–19; shaped 614
- reinforced concrete folded slab roofs 692
- reinforced concrete foundations 258–60; cantilever foundations 265; pad foundations 252, 263; raft foundations 264; strip foundations 258, 262
- reinforced concrete framed structures 596, 600
- reinforced concrete slabs, simply supported 592–4, 597–8
- reinforced concrete stairs 814–18

- reinforced concrete suspended floors 784–8;
  - sound insulation 799
- reinforced concrete walls: ground water control 356; retaining walls 294–6;
  - sound insulation 797
- reinforced mortar bed joints 338, 735
- reinforced stack bond 388
- rendering 479–81
- renders 479, 481
- render, thermal performance 551
- Renhex box pile 278
- replacement bored piles 266, 267–9
- residual current device (RCD) 920
- resin grouts 358
- resonant frequency test 139
- resorcinol formaldehyde 654
- restraint straps 773, 774
- retaining wall and raft basements 308
- retaining walls 287–303; design calculations 302–3; steel sheet piling 334–5
- retro-ties/straps 774
- reversed bond 383
- reversing drum mixer 235
- RIBA Plan of Work 83
- ribbed floors 785–6
- ridge boards 495, 497
- ridge detail: double lap tiling 507, 508;
  - northlights 671; roof sheet coverings 667, 669; single lap tiling 515; slating 516
- ridge tiles 505, 512
- ridge vents 508, 540
- rigid paving 166–7
- rim night latch 466
- rim rock 466
- ring circuits 924
- risers (stairs) 804
- road construction 162–71; drainage 876–7;
  - earthworks 165; kerbs, pavings and edgings 169–71; paving construction 165–7; setting out 162–4
- road gullies 877
- road signs 171
- road-works 195
- Robust Details 67
- rock asphalt 530
- rock, thermal conductivity 552
- rodding eyes 888
- roller shutter 467, 470
- roll over skip 233
- roll type tile 514
- roof coverings: double lap tiling 505–8, 512–13; lead covered roofs 532–4, 872; sheet materials 665–9; single lap tiling 514–15; slating 516–20; weights 38; *see also* underlays
- roofing felt 504
- roofing membranes 504, 510
- roofing tiles: double lap tiling 505–8, 512–13; single lap tiling 514–15;
  - storage on site 130
- rooflights 695–8; chimney flue height 933;
  - long span roofs 671–2; thermal performance 560, 561–2
- roofs 490; basic forms 491–3, 670; loads 15, 16; long span 670–8; performance requirements 490; pitches 491, 518, 522, 872; rainwater drainage 872–3; span types 496–9; surveys 30; thermal insulation 509–10; thermal performance 550, 551, 557–8, 560, 585; underlays 504; ventilation 508
- roof space: habitable 500, 501, 509, 542;
  - surveys 31; thermal insulation 569–71; ventilation 504, 540–2
- roof trusses: long span roofs 671; steel 663–4; timber 498
- roof vents 507, 540, 541; thermal performance 585
- roof windows: chimney flue height 933;
  - thermal performance 560, 585
- room-temperature vulcanising (RTV) 864
- root pile 347
- rotary bored piles 267, 270–1
- rotational dome 684
- rotational shell 9
- rough-cast 480
- RSC (rainscreen cladding) 577–8, 701, 705–7
- RTV (room-temperature vulcanising) 864
- rubble drain 869, 876
- rubble shutters 220
- rubble walls 376
- runner (excavations) 324
- run off 349
- rust staining of concrete 725
  
- SACs (shallow access chambers) 888
- saddle flashing 936
- safety *see* health and safety
- safety glass 842
- salvage, demolition 197
- sampling shells 97
- sand: bulking 133, 327; compaction 362;
  - silt in 134; testing 133–4
- sand-lime bricks *see* calcium silicate bricks
- sand pugging 801
- sandstone: sources 372; thermal performance 551
- sandy soils 245; angles of repose 322;
  - foundations 255; investigation 100–1

# Index

- sanitary accommodation, disabled access 589
- sanitary fittings 905–7; storage on site 131
- sanitary systems, airtightness testing 912
- sapele 859
- saponification 853
- SAP (standard assessment procedure) 33, 559
- sarking 504
- sash boxes 440
- sash windows 433, 439; secondary glazing for 452; spring balanced 441–2; weight balancing 440
- saws 854
- scabbing of concrete 725
- scaffolding 172–85; fittings 178; patent 179; safety checklist 185; scaffold boards 175; special systems 180–5; tubular 172–8
- scarf joints 651
- schedules (documentation) 20
- Schmidt hammer 137
- scissor stairs 814
- scrapers 206
- screed *see* concrete floor screeds
- screwed joint 904
- scrim tape 844
- SDR (styrene butadiene resin) 412
- sealants 863–5
- sealed warm roof 510
- secant piling 355
- secondary beams 7
- secondary elements 13
- secondary glazing 451–2
- sections, drawings 21
- security door chain 466
- security, site 115, 126
- SEDBUK ratings 562
- sedimentary rocks 371
- segmental arch 425
- segmental bay 445
- self-certification 65, 66
- self-levelling screeds 770
- self-propelled cranes 222
- separate screeds 769
- separating floors: sound insulation 799–802, 849; suspended ceilings 849
- separating walls 737–8; sound insulation 797, 802; *see also* party walls
- service openings: draughtproofing 583; fire protection 939
- service pipes: gas supply 927; water supply 893
- services, soffit and beam fixings 788
- setting, concrete 241
- setting out 154–61; roads 162
- settlement 341
- sewers 881, 885
- shallow access chambers (SACs) 888
- shear box test 108
- shear plate connector 678
- shear strength: notched timber joists and beams 779; soil tests 104–6, 107–8
- shear wall structure 660
- sheathed cables 921
- sheet glass 448
- sheet materials 860–1; roof coverings 665–9; storage on site 131; typical weights 38–9
- shell roofs 9, 684–91
- shiplap 482
- shoring 186–91
- short bored piles 248, 259
- showers 906
- shrinkage: subsoil 109, 246–8; timber 652
- shutters 467, 470
- side hand casement 433
- side lap 517
- sight rails 157
- signs and symbols: health and safety 56–7; road signs 171
- silane modified polymer sealant 864
- siliconates 411
- silicone damp-proof courses 411
- silicone sealants 708, 864
- sills 430, 431, 434; doors 465; thermal bridging 580; thermal insulation 581
- silty soil: foundations 255; investigation 100–1; shrinkage 109; thermal conductivity 552
- simply supported beam 5
- Simpson's rule 88
- single acting hammers 283
- single lap tiling 514–15
- single ply roofing membranes 535–6
- sinks 905
- SIPs (structured insulated panels) 511
- site access 112
- site accommodation 113, 122, 124; for materials 326
- site activities 19
- site areas, surveys 87–9
- site clearance 321
- site drawings 21, 87–9
- site investigations 90–1
- site layout 112–14, 129
- site lighting 119–20
- site measurement 87–9
- site mixed concrete 331
- site of building 4

- site plans 21, 27
- site preparation 365–7
- site security 115, 126
- site soil tests 104
- site storage 126–31, 326
- site survey 86–9, 365
- site tests 132–3
- Sitka spruce 858
- skeletal construction 7
- skeleton core door 835
- sketches 22
- skewback 425
- skimmers 209
- skirtings 857
- slabs *see* concrete bed/slab
- slate damp-proof courses 410
- slates 516, 517, 518
- slate sill 430
- slating 516–20
- sleepers walls 760
- slenderness ratio (SR): brickwork 419; timber stud partitions 741
- sliding doors 467, 468–9
- sliding partitions 745
- sliding sash windows 433, 439–40
- slipping sites: architectural form 4; setting out 158–60; solid ground floors 758; stepped foundations 257
- slotted bolt fixings 712
- slump (concrete) 331
- slump test 135
- slung scaffolds 180
- small detached buildings: building control exemptions 69; Energy Performance Certificates (EPC) 32; height limitations 391
- SMM (Standard Method of Measurement) 79, 83
- smoke resistance, internal doors 841
- snap headers 395
- soakaways 880, 882
- soakers: abutments 513; chimney stacks 935; slating 519; tile hanging 484, 485
- SOA (socket outlet assembly) 121
- socket outlet assembly (SOA) 121
- socket outlets 923–4
- soffit, arches 424
- soffit boards 507, 515
- soffit fixings 788
- softwood board, thermal performance 552
- softwood timber 858; strength grading 140–3; testing 140–6
- soil assessment and testing 100–11
- soil classification 100–1
- soil consolidation 108
- soil contaminants 365
- soil investigation 92–8, 360
- soil nailing 300
- soils: thermal conductivities 552; *see also* subsoil
- soil stabilisation 360–4
- soil washing 366
- soil water 868
- solar blinds 457
- solar gain, multiple glazing 455
- soldered capillary joint 904
- solid construction 7
- solid ground floors 758; *see also* concrete bed/slab
- solid masonry walls 382–90, 399; opening details 429, 430; sound insulation 797; thermal insulation 574, 577; U-values 572
- solid slab raft 251, 264
- solvent extraction, contaminated soil 367
- solvents, paint 850
- solvent weld joint 904
- sound insulation 795–802; improvements 802; internal walls 796–8; multiple glazing 450, 457; separating floors 799–802; suspended ceilings 849
- sound-resisting construction 18, 67; party/separating walls 738
- space decks 679–80
- space frames 681–3
- space grid structures 679–83
- spacers: concrete reinforcement 594, 608; double glazing 455; reinforced concrete walls 616
- span (arches) 425
- special bricks 395–7
- specifications 20; British Standards 73
- spindle moulders 854
- spine beam stairs 821
- spiral core door 835
- spiral stairs 831–2; concrete 816, 822; metal 824; timber 813
- splashlap (lead sheeting) 533
- splay bay 445
- split barrel sampler 104
- split ring connector 678
- spring balanced sash windows 441–2
- springers 424
- springing (arches) 424
- sprocket roofs 503
- stack bond 388
- stack discharge systems 908–11; airtightness testing 912
- staff bead 439, 440
- staining of concrete 725
- stainless steel sinks 905

- stairs 803–32; access for the disabled 589; alternating tread 810; balustrades and handrails 826; in-situ reinforced concrete 814–18; with landings 811–12; metal 823–5; open risers 808–9; precast concrete 819–22; public and general use 827; spiral 813, 816, 831–2; surveys 31; tapered treads 828–30; timber 805–13
- stairwell trimming 775
- stair winders 829–30
- standard assessment procedure (SAP) 33, 559
- Standard Method of Measurement (SMM) 79, 83
- standard penetration test 104
- standing skip 233
- star rating 72
- static tower cranes 228, 229
- statutory listing 152
- steel bar reinforcement 606
- steel box piles 278
- steel decking 594–5; thermal insulation 571
- steel frame construction 477–8
- steel girders 674
- steel grillage 263
- steel joists 629
- steel mesh reinforcement 607
- steel, painting 852
- steel reinforcement 593, 606–7; *see also* reinforced concrete
- steel roof trusses 663–4
- steel screw piles 278
- steel sheet piling 334–6, 354
- steel spiral stairs 824
- steel string stairs 825
- steel trench sheeting 324, 335
- steel tube piles 279
- steel web lattice joists 657
- steel windows 437
- steelwork *see* structural steelwork
- step formats (stairs) 805, 806
- stepped barrel vaults 687
- stepped flashing 513, 935
- stepped foundations 257
- stepped ventilator 761
- stitched joints 473
- stone chippings, thermal performance 551
- stone cladding 375
- stonework 371–8; thermal performance 551; types of stone 371–3; *see also* cast stone
- stop valve 901
- storage on site 126–31, 326
- storey-height cladding panels 716
- storey-height doorset 837
- storey-height frames 836
- straight mast fork lift 216
- straight web pile 334
- strawboard 860
- stretchers 383
- string beam stair 815
- string over string stairs 812
- string (stairs) 805, 806
- stripboard 860
- strip foundations 251, 262; reinforced concrete 258, 262; and subsoil movements 247, 248; width 255
- structural glazing 709
- structural grid 52
- structural sealant glazed cladding 708
- structural steel beams 630, 631–2; connections 633–4; design 640–3; for precast concrete floors 792–3
- structural steel columns 630; connections 633–4; design 644–5
- structural steelwork 628–44; beam design 640–3; column design 644–5; compound sections 630; connections 633–7, 649; fire protection 638–9; lattice beams 632; open web beams 631; portal frames 649; standard sections 628–9
- structural timber: beams 655–6; portal frames 650; strength grading 140–3; typical weights 39
- structured insulated panels (SIPs) 511
- structure types and forms 5–10
- struts 5, 192–4; timber roofs 497; timber stud partitions 741
- strutting, timber suspended upper floors 772
- stucco 749
- stud partitions 740–3; fire protection 743; sound insulation 796
- styrene butadiene resin (SDR) 412
- subsoil: angles of repose 322; contaminated 365–6; drainage 869–70, 876; movements 245–6; *see also* soils
- subsoil water 349, 868
- substructure 11
- SUDS (sustainable urban drainage systems) 874–5
- sulphate-resisting cement 325
- sump pumping 350–2
- superstructure 12
- surcharging (soil stabilisation) 360
- surface emissivity 550
- surface finishes 14; concrete 721–5, 766; surveys 31; typical weights 39; *see also* wall finishes
- surface preparation 852
- surface resistances 550
- surface water 349, 868; drainage 872–80

- surveyors 28  
 surveys: building survey 29–31; demolition preliminaries 197; site 86; site investigations 90–1; tools and equipment 29  
 suspended ceilings 845; sound and thermal insulation 849; sound insulation 849  
 suspended concrete floors 761–2, 784–93; sound insulation 799; thermal insulation 579  
 suspended scaffolds 181  
 suspended structures 661  
 suspended timber floors, sound insulation 796  
 suspended timber ground floors 758, 760; thermal insulation 579  
 suspended timber upper floors 771–6; fire protection 782–3; joists and beams 776–81; sound insulation 800–1  
 sustainability 72  
 sustainable demolition 199  
 sustainable drainage systems (SuDS) 874–5  
 sustainable urban drainage systems (SUDS) 874–5  
 swept valley 520  
 swing doors 843  
 swivel skip dumper 215  
 symbols 42–3; health and safety 56–7; road signs 171  
  
 tack welding 336  
 tall buildings 658–62  
 tamping board vibrators 238  
 tamping (concreting) 238–9  
 tanking 315–16  
 tapered treads 828  
 target emission rate (TER) 33, 567  
 target fabric energy efficiency (TFEE) 567  
 TA (transformer assembly) 121  
 TBM (temporary bench mark) 154, 158  
 teak 859  
 technical drawings 21  
 telephone installations 940  
 telescopic boom crane 223  
 telescopic boom fork lift 216  
 tell-tales 249  
 temporary bench mark (TBM) 154, 158  
 temporary buildings, Energy Performance Certificates (EPC) 32  
 temporary platforms 172  
 temporary services 113  
 temporary support: arches 425; excavations 322–4; loads 192–4  
 tendons: reinforced concrete 622; soil nailing 300  
 tenoning machines 854  
  
 tension cable structure 10  
 tension membrane structures 10, 693–4  
 tension straps 773, 774  
 terrazzo finish 724  
 TER (target emission rate) 33, 567  
 textured finishes: concrete 721; rendering 480  
 TFEE (target fabric energy efficiency) 567  
 thatching 521  
 theodolites 161  
 thermal breaks: aluminium casement windows 454; double glazing 450  
 thermal bridging 414, 580–2  
 thermalcheck plasterboard 753  
 thermal conductivities 551–2  
 thermal insulation: basements 318; cavity walls 568, 572–3, 575–6, 578, 581–2; CO<sub>2</sub> reduction 568; damp-proof courses (dpc) 414; densities 552; domestic ground floors 759, 760; external solid walls 574, 577; improvements 574–8; performance standards 71; roofs 509–10; roof space 569–71; suspended ceilings 849; thermal conductivities 552; timber flat roofs 528, 530; timber frame construction 476; typical weights 39; water storage cisterns 902  
 thermal movement 532, 735  
 thermal performance: buildings other than dwellings 584–5; double skin roof coverings 669; dwellings 559–65; elements of construction 560–2; energy efficiency rating 559; targets for buildings other than dwellings 585; targets for dwellings 560–3, 567–8; U-value calculations 548–58  
 thermal resistance 549  
 thermal transmittance *see* U-values  
 thermal treatments, contaminated soil 367  
 thermoplastics 862; roof coverings 535  
 thermosetting plastics 862  
 thermostatic mixing valves 900  
 thicknessers 854  
 thin grouted membranes 354  
 thinners, paint 850  
 third bonding 383  
 three-dimensional drawings 24–5  
 tie bolts 616  
 ties 6; *see also* wall ties  
 tile hanging 482, 484–8; thermal performance 551  
 tile profile sheets 665  
 tiles: cladding 482, 484–8; double lap 505–8, 512–13; single lap 514; *see also* floor tiles; wall tiles  
 tile ventilators 507



- tilting drum mixer 235
- tilting level 159
- timber: characteristics and tolerances 143–6; fungal decay 149–50; moisture content 148, 651; painting 852; preservatives 150, 654; scaffold boards 175; shrinkage 652; sills 430; sizes and surface finishes 147; storage on site 128, 130, 131; strength grading 140–3; testing 140–6; *see also* hardwoods; laminated timber; softwood timber; structural timber
- timber beams: notched 779; sizing 777–8; structural 655–6
- timber boards 860–1; flat roof decks 527; thermal performance 551
- timber casement windows 434–5
- timber cladding 482, 483
- timber connectors 678
- timber flat roofs 522–36; coverings 529–34; flat roof decks 527; joists 523–6; thermal insulation 528, 571
- timber floorboards 765
- timber frame construction 475–6; fire- and sound-resisting construction 738; rendering 480; sound insulation 798; U-values 573
- timber hyperbolic paraboloid shells 690–1
- timbering, excavations 323
- timber joists *see* joists
- timber mouldings 857
- timber piles 275
- timber pitched roofs 494–503, 543–5; preservation 544–5; thermal insulation 570; thermal performance 557–8
- timber roof trusses 498
- timber stairs 805–13
- timber strip flooring 765
- timber stud partitions *see* stud partitions
- timber support frames, rainscreen cladding (RSC) 706
- timber suspended floors *see* suspended timber floors
- tolerances, masonry walls 407
- tongue and groove boarding 765
- tooled finishes, concrete 721
- toothed plate timber connectors 498, 678
- top down construction (basements) 310–12
- top hung casement 433
- topsoil removal 319, 321
- torque bolts 637
- tower cranes 221, 228–31
- TPO (tree preservation orders) 151, 248
- track mounted cranes 225
- tractor shovels 208
- transformer assembly (TA) 121
- translational dome 9, 684
- translucent glass 448
- transoms 434, 445, 836
- transport vehicles 214–16
- transverse reinforcement 601
- trapezoidal rule 89
- travelling tower cranes 228, 231
- treads (stairs) 804, 828
- tree preservation orders (TPO) 151, 248
- trees, damage to buildings 246–8
- tremie pipes 269, 270
- trenches: drains 889; excavations 320, 321; perimeter trench excavations 305; setting out 155; temporary support 322–4; utility services 171
- trench fill foundations 251, 262; and subsoil movements 248
- trial pits 92, 96
- triaxial compression test 107
- tricalcium aluminate, in Portland cement 325
- trimming: floor openings 775; moulding profiles 857; roof openings 935
- triple glazing 456–7; thermal performance 561
- troughed floor 785–6
- trough type tile 514
- trunking (electrical) 921
- trussed purlin roof 500
- trussed purlins 655
- trussed rafters 499
- truss-out scaffolds 183
- tube core structure 660
- tube piles 279
- tube spacers 616
- tubular lattice steel beams 632
- tubular scaffolding 172–8
- Tudor style door 464
- tundish 898
- tunnel kiln 380
- tying-in (scaffolds) 176
- UF *see* urea formaldehyde (UF)
- UKAS (United Kingdom Accreditation Service) 76
- unauthorised building work 68
- unbonded screeds 769
- unconfined compression test 106
- undercloak 487, 533
- undercoats 851
- underlays: lead sheeting 532; slating 519, 520; vapour permeable 504, 510
- underpinning 341–8
- undersill cladding panels 715
- Uniclass 80, 83
- United Kingdom Accreditation Service (UKAS) 76
- universal beams and columns 629

- universal bearing pile 278
- urea formaldehyde (UF) foam: cavity wall insulation 575; thermal performance 552
- urea formaldehyde (UF) glue 654
- utility services 113, 153; detecting/locating 153; laying 171; *see also* public utility services
- U-values: calculations 548–58; cavity walls 572–3, 575–6, 578; elements of construction 560–1, 585; low emissivity glazing 453, 454, 456; structured insulated panels (SIPs) 511; thermal insulation 570–1
- vacuum dewatering 767
- valley detail 512; northlights 671; roof sheet coverings 669; slating 520
- valley gutter 872
- valley rafter 495
- valleys (roofs) 502
- valley tiles 505
- vane test 105
- vapourcheck plasterboard 540, 753, 844
- vapour control layers 510; roof spaces 540; timber flat roofs 528
- vapour extraction, contaminated soil 366
- vapour permeable underlay 504, 510
- vehicles, transport 214–16
- Venetian blinds, in triple glazing 457
- ventilated cold roof 510
- ventilated stack systems 909
- ventilation: combustion air 937; roofs 504, 507, 508, 515; roof space 540–2
- ventlight catch 438
- vent pipe flashing 911
- verge detail: double lap tiling 513; timber flat roofs 524
- vertical pivot (window) 433
- vertical stack bond 388
- vertical strut 5
- vibrating hammer 285
- vibration compacting 361–2
- vibration test, concrete 139
- vibrators (concreting) 238
- Vierendeel girder 674
- vision panels 842
- volume batching 327, 331
- vousoirs 424, 425
- vulcanising additives 864
- waffle floor 785–6
- wallboard 753, 844
- wall finishes 14, 747–57; dry lining 750–2; plaster 747–8; plasterboard 753–5; stucco 749; wall tiling 756–7; *see also* cladding
- wall inset 158
- wall panelling 856
- wall plates 507, 515
- wall profiles 733
- walls: ashlar 374–5, 377; attached piers 389–90; cracking in 249; diaphragm 406; finned 405; formwork 615–16; lateral restraint 773–4; loads 15; rubble 376–7; solid block 399; solid brick 382–90; surveys 30; thermal performance 549–51; underpinning 342; *see also* blockwork; brickwork; cavity walls; external walls; internal walls; masonry walls; separating walls
- wall ties 392, 400, 429, 616; construction joints 734; masonry partitions 739; retro-ties 774; thermal performance 551, 552; *see also* bonding ties
- wall tiles 756–7; *see also* ceramic tiles
- warm decks 523, 524, 525, 528; thermal insulation 571
- warm roofs 509–10
- warning signs 56–7
- warranties, house builders' 67
- wash boring 98
- washing facilities on site 124
- waste, demolition 199
- waste water 868
- waste water discharge 908–11
- water: in cement 325; dewatering 349; subsoil 349, 868; *see also* surface water
- water bars: basement construction 314; door sills 465
- water-based paints 850
- water/cement ratio 250, 328–9
- water closets 907
- water installations: cisterns 902–3; cold water 894–5; flow controls 901; hot water 896–900; pipework joints 904
- water main 892
- waterproofing, basements 313–17
- water retention, concrete 240, 241
- water storage cisterns 902–3
- water supply 892–3
- water table 349, 869
- water taps 901
- watertightness testing 890
- wc's 907
- weatherboarding 482
- weathering, artificial stones 373
- weathering details: abutments 513, 524, 530, 536; chimney stacks 935–6; concrete claddings 718; discharge stacks 911; *see also* abutment details; flashings; soakers
- weep holes 287, 408
- weighing hopper 328

## Index

- weight/weigh batching 328, 331
- welded connections 636
- wellpoint systems 352–3
- welted joints 532
- western hemlock 858
- western red cedar 858
- Winchester cutting 487
- winder flights 829–30
- window heads 431; thermal performance 580, 581
- window jambs 431; thermal performance 580, 581
- windows 432–50; bay 445; casement 434–8; draughtproofing 583; emergency escape 432; high performance 435; ironmongery 438; notation 447; performance requirements 432; pivot 444; sash 439–43; schedules 446; thermal performance 560, 561–2, 566, 585; types 433; *see also* glazing; rooflights
- window sills 430, 431, 434; thermal bridging 580; thermal insulation 581
- Windsor probe test 138
- wired glass 448
- wood block flooring 765
- wood boring insects 544–5
- wood cement board 861
- wood chipboard *see* chipboard
- wood cored rolls and drips 533, 534
- wood glue 654
- wood panelling 856
- woodwool slabs 861; flat roof decks 527; thermal performance 551
- woodworking machines 854
- woodworm control 544
- workability of concrete 328–9
- Work at Height Regulations 2005 54
- working platforms 175
- workmanship 28
- workshops 391
- wrecking balls 198
- zero carbon home 72
- zones (construction grids) 53